

856990

403.5 MHz SAW Filter

Applications

- Medical Applications
- 402 - 405 MHz MICS Band

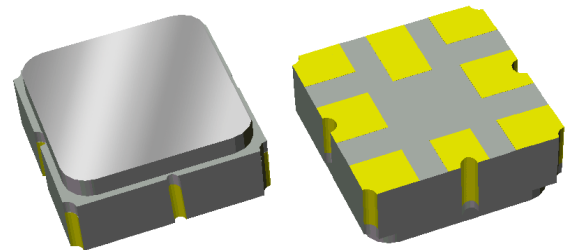

Product Features

- Usable bandwidth 3 MHz
- Low loss
- Balanced to Single-ended operation
- No impedance matching required
- Small Size: 3.00 x 3.00 x 1.22 mm
- Ceramic Surface Mount Package (SMP)
- Hermetically sealed
- **RoHS** compliant (2002/95/EC), **Pb-free** 

General Description

856990 is a high-performance IF SAW filter with a center frequency of 403.5 MHz and bandwidth of 3 MHz designed to provide front-end selectivity in the 402-405 MHz band. It features low loss with excellent attenuation, and is designed to be used with a Balanced to Single-ended operation. It is ideal for short range wireless medical data applications where small size and low power consumption are required features. This device is RoHS compliant and Pb-free.

Functional Block Diagram

Top view

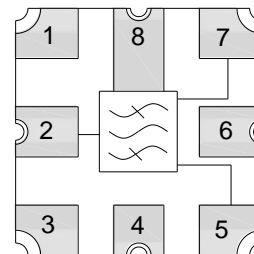

Pin Configuration

Pin #	Bal/Se	Description
5		Input -
7		Input +
2		Output -
1,3,6		To be Grounded
4,8		Case Ground

Ordering Information

Part No.	Description
856990	packaged part
856990-EVB	evaluation board

Standard T/R size = 5000 units/reel.

Specifications

Electrical Specifications ⁽¹⁾

Specified Temperature Range: ⁽²⁾ 0 to +55 °C

Parameter ⁽³⁾	Conditions	Min	Typical ⁽⁴⁾	Max	Units
Center Frequency		-	403.5	-	MHz
Amplitude Variation ⁽⁵⁾	402 – 405 MHz	-	0.5	1.0	dBp-p
Insertion Loss	402 – 405 MHz	-	2.1	3.0	dB
Absolute Attenuation ⁽⁶⁾	10 – 390 MHz	30	40	-	dB
	390 – 398 MHz	20	37	-	dB
	410 – 428 MHz	20	24	-	dB
	428 – 2000 MHz	30	36	-	dB
Source Impedance ⁽⁷⁾	Balanced	-	120	-	Ω
Load Impedance ⁽⁷⁾	Single-ended	-	30	-	Ω

Notes:

- All specifications are based on the TriQuint schematic for the main reference design shown on page 3
- In production, devices will be tested at room temperature to a guardbanded specification to ensure electrical compliance over temperature
- Electrical margin has been built into the design to account for the variations due to temperature drift and manufacturing tolerances
- Typical values are based on average measurements at room temperature
- Amplitude Variation is defined as the difference between the lowest and highest responses between 402 and 405 MHz.
- Relative to zero dB
- This is the optimum impedance in order to achieve the performance shown

Absolute Maximum Ratings

Operation of this device outside the parameter ranges given above may cause permanent damage.

Parameter	Rating
Operable Temperature ⁽⁸⁾	-40 to +85 °C
Storage Temperature	-40 to +85 °C
Input Power ⁽⁹⁾	+10 dBm

- Device may operate over this range with degraded Electrical Specifications
- Device may be operable at this level for the equivalent 5K hours @ +40°C [CW Signal]

Reference Design 120Ω Bal Input/30Ω SE output

Schematic

120 Ω
Balanced
Input

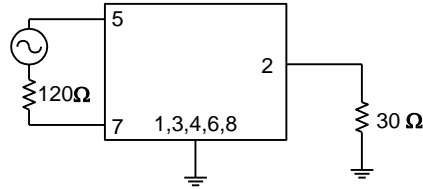

30 Ω
Single-ended
Output

Notes:

1. No impedance matching required
2. Actual matching values may vary due to PCB layout and parasitic

PC Board

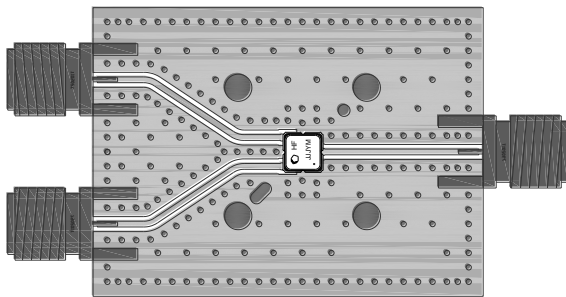

Mounting Configuration

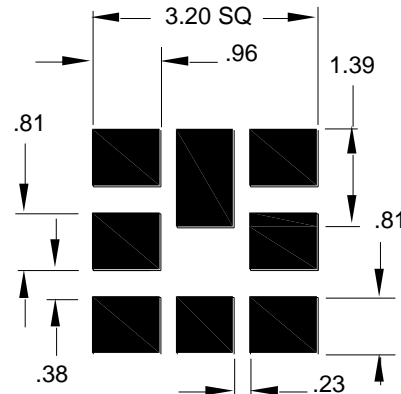

Notes:

Top, middle & bottom layers: 1 oz copper
Substrates: FR4 dielectric, .031" thick
Finish plating: Nickel: 3-8μm thick, Gold: .03-.2μm thick
Hole plating: Copper min .0008μm thick

Notes:

1. All dimensions are in millimeters.
2. This footprint represents a recommendation only.

Bill of Material

Reference Desg.	Value	Description	Manufacturer	Part Number
SMA	N/A	SMA connector	Radiall USA Inc.	9602-1111-018
PCB	N/A	3-layer	multiple	960563

Typical Performance (at room temperature) Reference Design

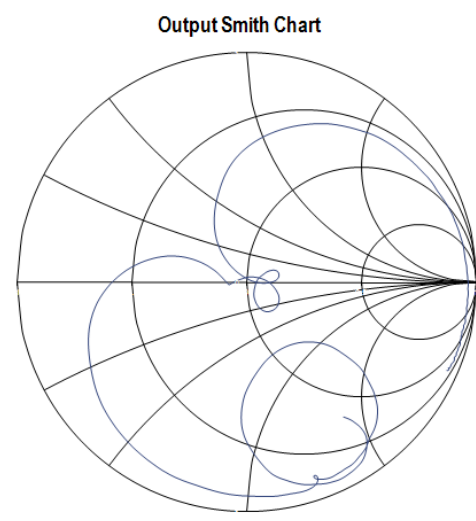
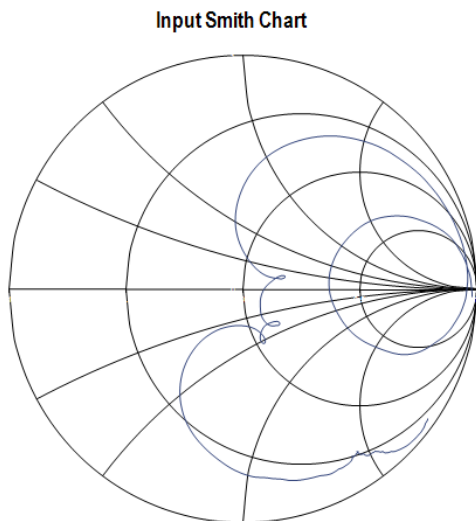
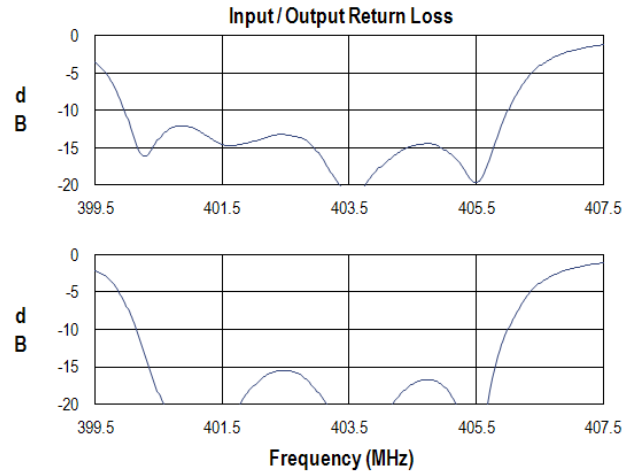
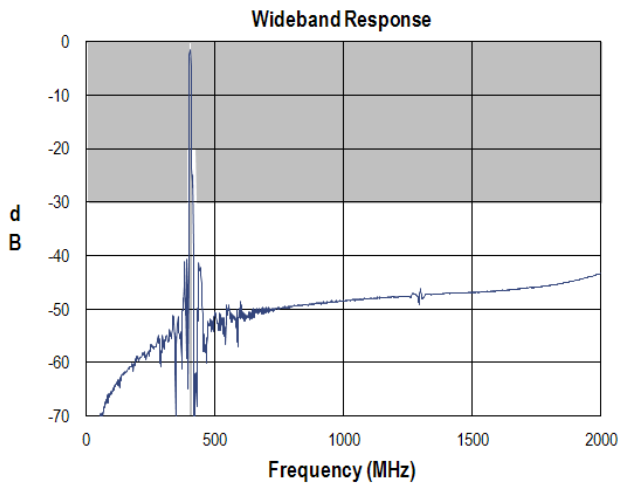
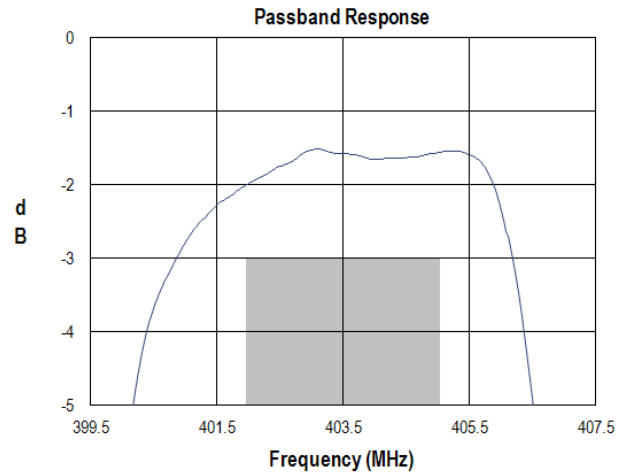
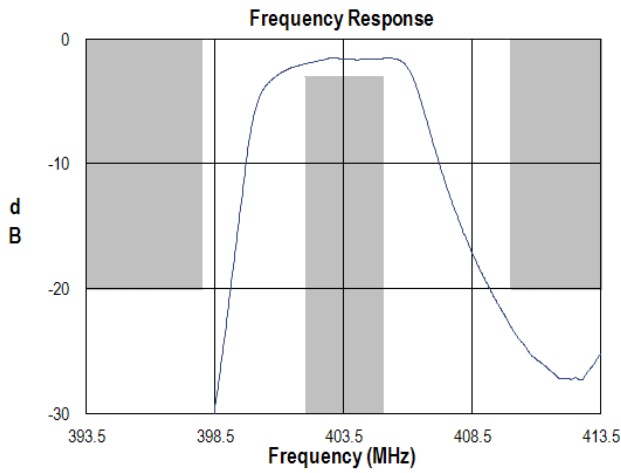

856990

403.5 MHz SAW Filter

Mechanical Information

Package Information, Dimensions and Marking

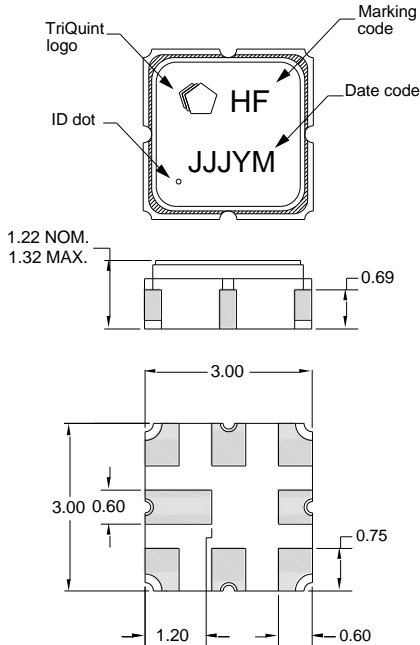

Package Style: SMP-12D
Dimensions: 3.00 x 3.00 x 1.22 mm

Body: Al_2O_3 ceramic
Lid: Kovar, Ni plated
Terminations: Au plating 0.5 - 1.0 μ m, over a 2-6 μ m Ni plating

All dimensions shown are nominal in millimeters
All tolerances are ± 0.15 mm except overall length and width ± 0.10 mm

The date code consists of day of the current year (Julian, 3 digits), Y = last digit of the year, and M = manufacturing site code

Tape and Reel Information

Standard T/R size = 5000 units/reel. All dimensions are in millimeters

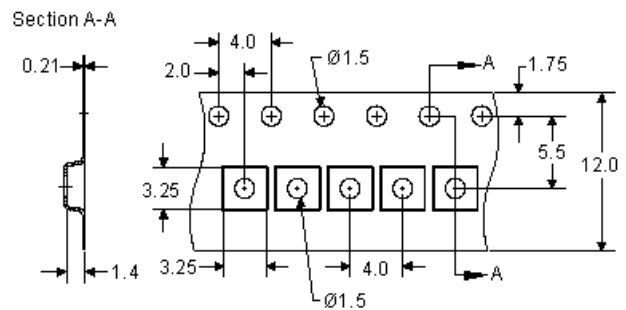
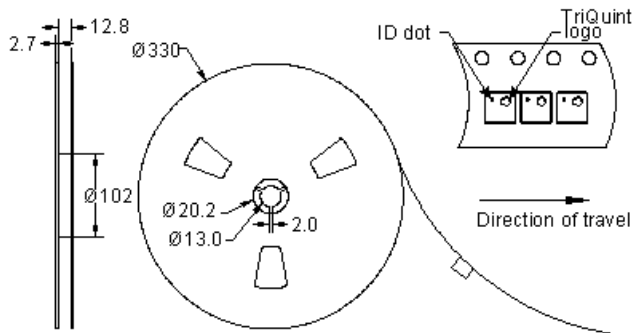

856990

403.5 MHz SAW Filter

Product Compliance Information

ESD Information



Caution! ESD-Sensitive Device

ESD Rating: 1B

Value: Passes $\geq 500V$ min.
Test: Human Body Model (HBM)
Standard: JEDEC Standard JESD22-A114

ESD Rating: A

Value: Passes $\geq 150V$ min.
Test: Machine Model (MM)
Standard: JEDEC Standard JESD22-A115

MSL Rating

Devices are Hermetic, therefore MSL is not applicable

Solderability

Compatible with the latest version of J-STD-020, lead free solder, 260°C

Refer to [Soldering Profile](#) for recommended guidelines.

This part is compliant with EU 2002/95/EC RoHS directive (Restrictions on the Use of Certain Hazardous Substances in Electrical and Electronic Equipment).

This product also has the following attributes:

- Halogen Free (Chlorine, Bromine)
- Antimony Free
- TBBP-A (C₁₅H₁₂Br₄O₂) Free
- PFOS Free
- SVHC Free

Contact Information

For the latest specifications, additional product information, worldwide sales and distribution locations, and information about TriQuint:

Web: www.triquint.com
Email: info-sales@tqs.com

Tel: +1.407.886.8860
Fax: +1.407.886.7061

For technical questions and application information:

Email: flapplication.engineering@tqs.com

Important Notice

The information contained herein is believed to be reliable. TriQuint makes no warranties regarding the information contained herein. TriQuint assumes no responsibility or liability whatsoever for any of the information contained herein. TriQuint assumes no responsibility or liability whatsoever for the use of the information contained herein. The information contained herein is provided "AS IS, WHERE IS" and with all faults, and the entire risk associated with such information is entirely with the user. All information contained herein is subject to change without notice. Customers should obtain and verify the latest relevant information before placing orders for TriQuint products. The information contained herein or any use of such information does not grant, explicitly or implicitly, to any party any patent rights, licenses, or any other intellectual property rights, whether with regard to such information itself or anything described by such information.

TriQuint products are not warranted or authorized for use as critical components in medical, life-saving, or life-sustaining applications, or other applications where a failure would reasonably be expected to cause severe personal injury or death.