

## Applications

- Point-to-Point Radio
- Ka-Band VSAT Ground Terminal
- Point-to-Multipoint Communications

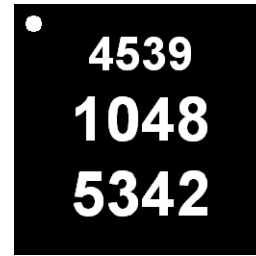

QFN 5x5 mm 20L

## Product Features

- Frequency Range: 28 – 30 GHz
- Power: 30.5 dBm Psat, 30 dBm P1dB
- Gain: 20 dB
- Bias: Vd = 6 V, Idq = 420 mA, Vg = -0.59 V Typical
- Package Dimensions: 5.0 x 5.0 x 1.3 mm

## Functional Block Diagram

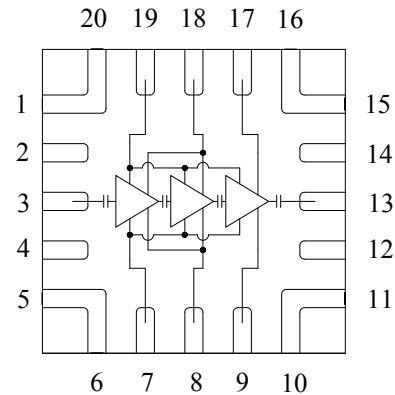

## General Description

The TriQuint TGA4539-SM is a Ka-Band 1 Watt Power Amplifier. The TGA4539-SM operates from 28 – 30 GHz and is designed using TriQuint's power pHEMT production process.

The TGA4539-SM typically provides 30.5 dBm of saturated output power with small signal gain of 20 dB.

The TGA4539-SM is available in a low-cost, surface mount 20 lead 5x5 mm QFN package and is ideally suited for Point-to-Point Radio, Point-to-Multipoint and VSAT communications.

Lead-free and RoHS compliant

Evaluation Boards are available upon request.

## Pin Configuration

Pin #	Symbol
1, 2, 4, 5, 6, 10, 11, 12, 14, 15, 16, 20	N/C
3	RF IN
7, 19	Vg
8	Vd1,2_Bot
9	Vd3_Bot
13	RF OUT
17	Vd3_Top
18	Vd1,2_Top

## Ordering Information

Part No.	ECCN	Description
TGA4539-SM	3A001.b.2.c	Ka-Band Power Amplifier

Standard T/R size = 500 pieces on a 7" reel.

## Specifications

### Absolute Maximum Ratings

Parameter	Rating
Drain Voltage, Vd	+8 V
Gate Voltage, Vg	-5 to 0 V
Drain to Gate Voltage, Vd – Vg	12 V
Drain Current, Id	984 mA
Gate Current, Ig	35 mA
Power Dissipation, Pdiss	6.9 W
RF Input Power, CW, T = 25°C	22 dBm
Channel Temperature, Tch	200 °C
Mounting Temperature (30 Seconds)	260 °C
Storage Temperature	-40 to 150 °C

Operation of this device outside the parameter ranges given above may cause permanent damage. These are stress ratings only, and functional operation of the device at these conditions is not implied.

### Recommended Operating Conditions

Parameter	Min	Typical	Max	Units
Vd		6		V
Idq		420		mA
Id_drive (Under RF Drive, Constant Vg)		800		mA
Vg		-0.59		V

Electrical specifications are measured at specified test conditions.  
Specifications are not guaranteed over all recommended operating conditions.

### Electrical Specifications

Test conditions unless otherwise noted: 25°C, Vd = 6 V, Idq = 420 mA, Vg = -0.59 V Typical.

Parameter	Min	Typical	Max	Units
Operational Frequency Range	28		30	GHz
Gain	15.5	20		dB
Input Return Loss		15		dB
Output Return Loss		10		dB
Output Power @ Saturation	29.5	30.5		dBm
Output Power @ 1dB Gain Compression		30		dBm
Output TOI @ 26 dBm Pout/tone		33		dBm
Gain Temperature Coefficient		-0.06		dB/°C
Power Temperature Coefficient		-0.02		dB/°C

## Specifications (cont.)

### Thermal and Reliability Information

Parameter	Condition	Rating
Thermal Resistance, $\theta_{JC}$ , measured to back of package	Tbase = 70 °C	$\theta_{JC} = 21.9$ °C/W
Channel Temperature (Tch), and Median Lifetime (Tm)	Tbase = 70 °C, Vd = 6 V, Idq = 420 mA, Pdiss = 2.52 W	Tch = 125 °C Tm = 1.0 E+7 Hours
Channel Temperature (Tch), and Median Lifetime (Tm) Under RF Drive	Tbase = 70 °C, Vd = 6 V, Id = 800 mA, Pout = 30.5 dBm, Pdiss = 3.8 W	Tch = 153 °C Tm = 9.6 E+5 Hours

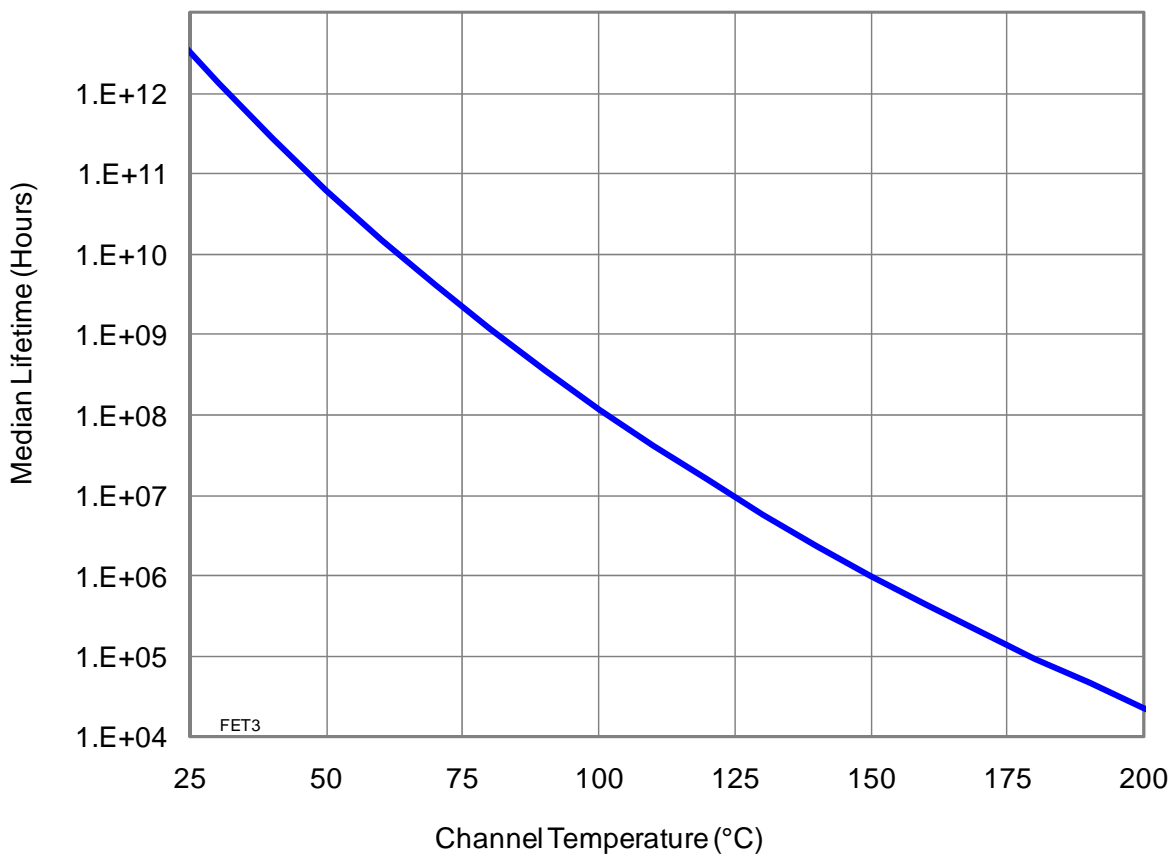

**Typical Performance**

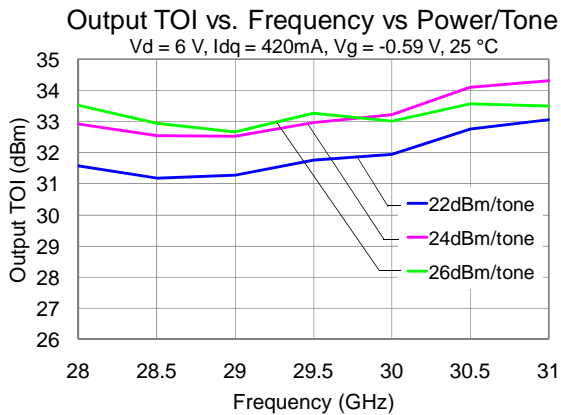
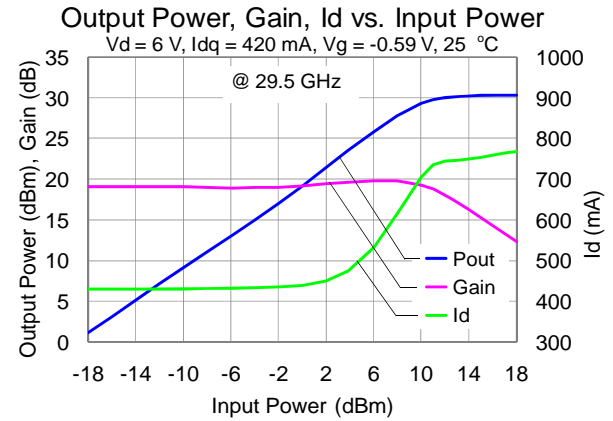
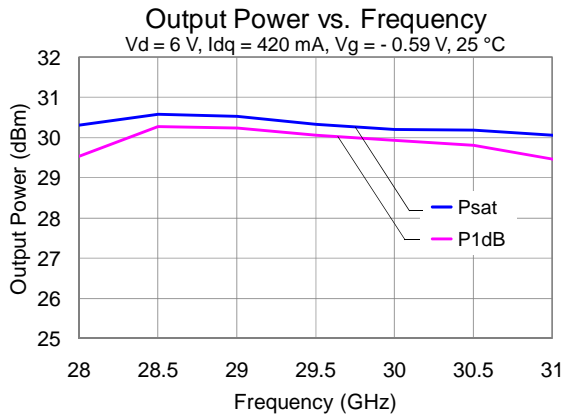
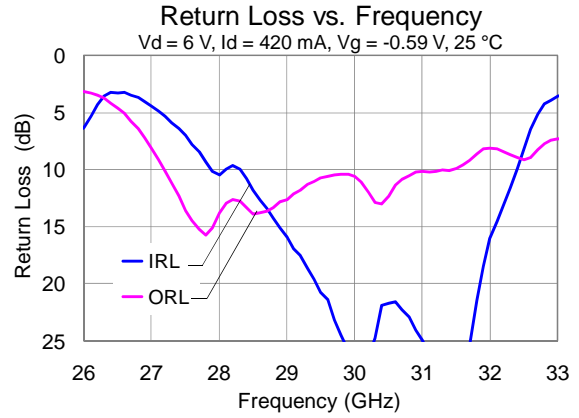
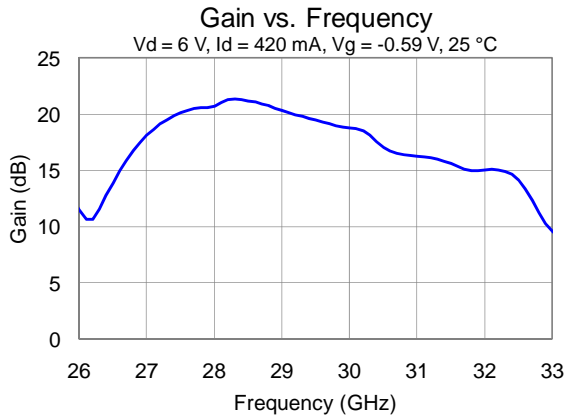

# TGA4539-SM

## Ka-Band 1 Watt Power Amplifier



### Typical Performance (cont.)

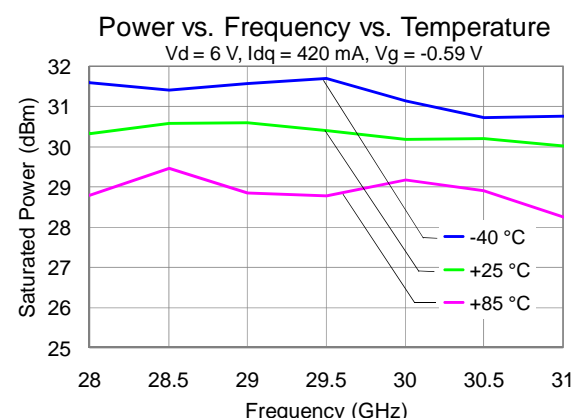
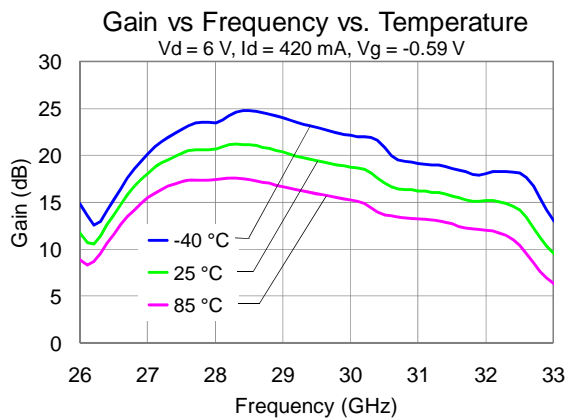
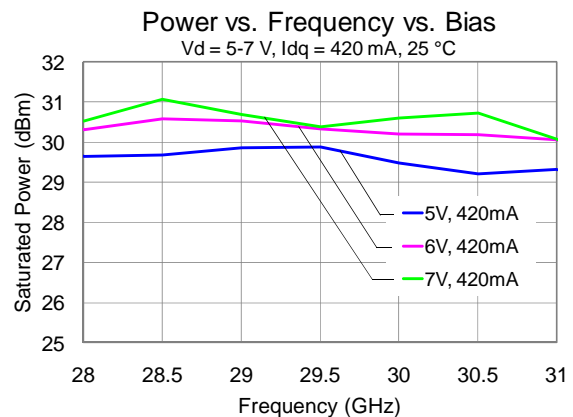
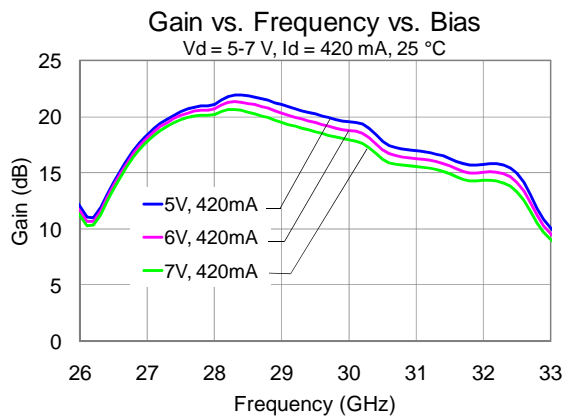
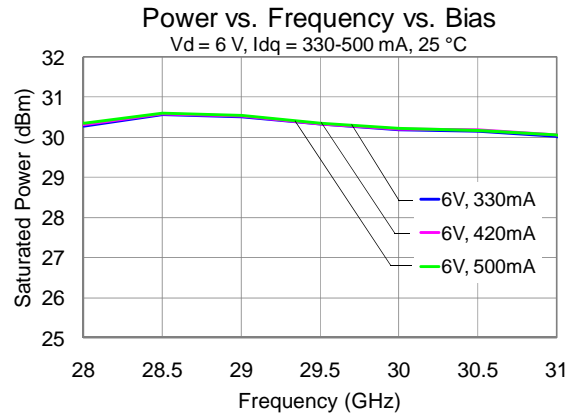
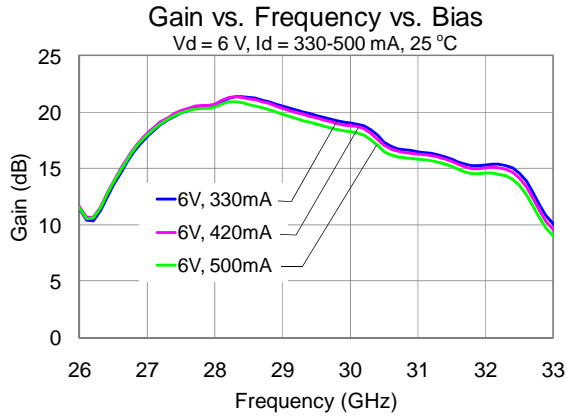

## Device Characterization Data

### Load Pull Data

RF performance of the TGA4539-SM is optimum when placed in the impedance environment specified below. These impedances are NOT the impedances of the device; they are the impedances presented to the device via an RF circuit or load pull system.  $Z_{LOAD}$  is the load impedance presented at pin 13. For load pull contours, refer to the [TGA4539-SM Product Information page](#).

The power data points shown below were measured in a load pull system. The power data points shown in ‘Typical Performance’ were measured using the input and output structures shown in ‘PC Board Tuning Layout’ and can vary from the load pull measurements.

**Test Conditions:**  $V_d = 6.0\text{ V}$ ,  $I_{dq} = 420\text{ mA}$ ,  $25^\circ\text{C}$   
 Input power for load pull: +16 dBm.  $Z_{SOURCE}$  for load pull:  $50 + j0$

Freq (GHz)	$\Gamma_{LOAD}$	$Z_{LOAD}(\Omega)$	Output Power (dBm)
28.0	Mag=0.371 Ang=30.1°	$86.5 + j37.5$	30.97
29.25	Mag=0.339 Ang=79.2°	$44.8 + j33.8$	30.66
30.0	Mag=0.375 Ang=91.1°	$37.2 + j32.5$	30.29
31.0	Mag=0.429 Ang=112.4°	$27.0 + j26.3$	30.06

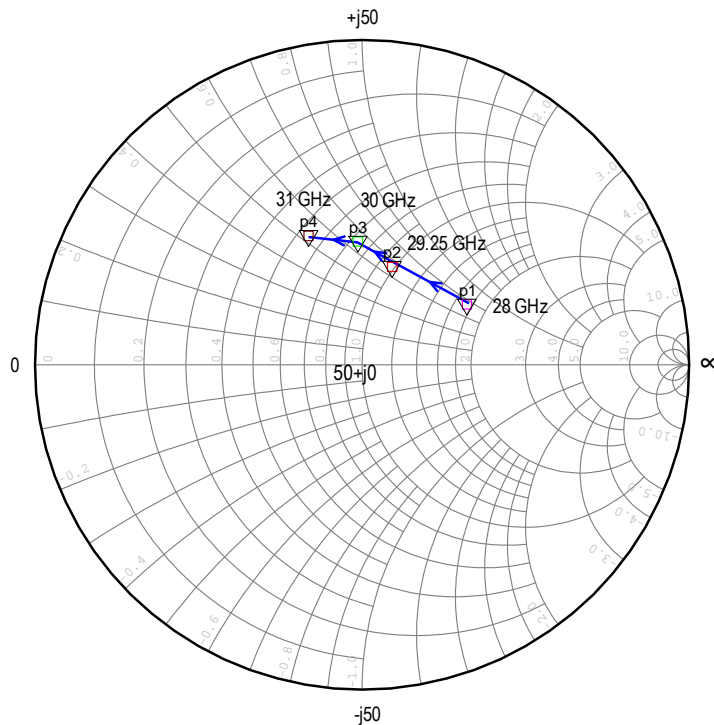

## Application Circuit

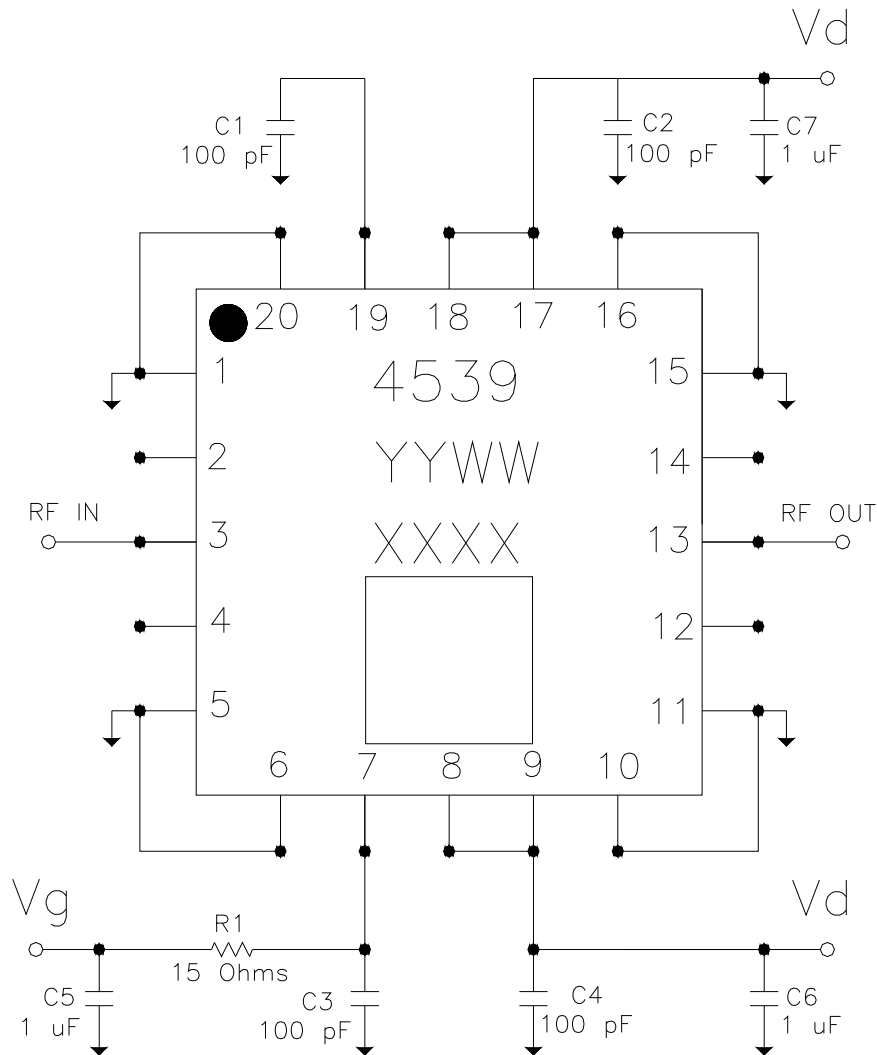

Vg can be biased from either side (pin 7 or pin 19)  
 Vd must be biased from both side (pins 8, 9, 17, 18)

### Bias-up Procedure

Turn Vg to -1.5 V  
 Turn Vd to +6 V  
 Adjust Vg more positive until quiescent Id is 420 mA.  
 This will be ~ Vg = -0.59 V typical  
 Apply RF signal

### Bias-down Procedure

Turn off RF signal  
 Reduce Vg to -1.5V. Ensure Id ~ 0 mA  
 Turn Vd to 0 V  
 Turn Vg to 0 V

## Pin Description

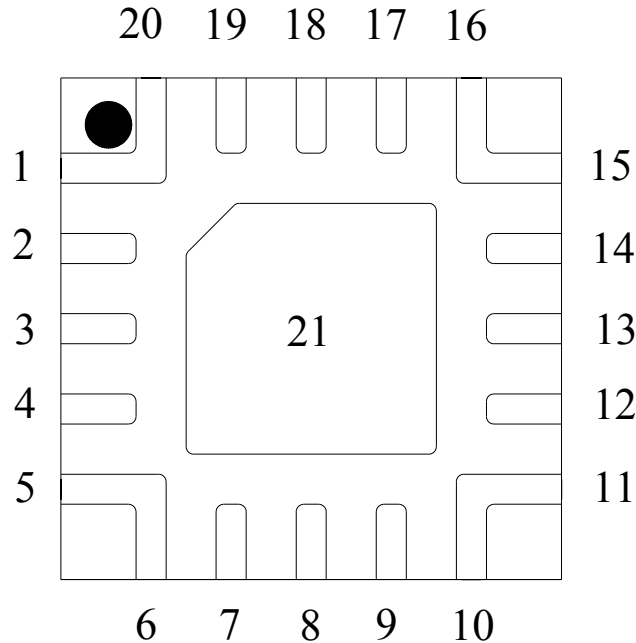

Pin	Symbol	Description
1, 5, 6, 10, 11, 15, 16, 20	N/C	Internally connected to 21; must be grounded on PCB.
2, 4, 12, 14	N/C	No internal connection; open on PCB for best performance.
3	RF IN	Input, matched to 50 ohms.
7, 19	Vg	Gate voltage. See Note 1
13	RF OUT	Output, matched to 50 ohms.
8,18	Vd12_Bot Vd12_Top	Drain voltage for 1 <sup>st</sup> and 2 <sup>nd</sup> Stage. See Note 2
9,17	Vd3_Bot Vd3_Top	Drain voltage for 3 <sup>rd</sup> Stage. See Note 2
21	GND	Backside Paddle. Multiple vias should be employed to minimize inductance and thermal resistance; see Mounting Configuration on page 12 for suggested footprint.

Notes:

1. Bias network is required; can be biased from either side (pin 7 or pin 19); see Application Circuit on page 7 as an example.
2. Bias network is required; must be biased from both side (pins 8, 9, 17, 18); see Application Circuit on page 7 as an example.



## Applications Information

### PC Board Layout

Top RF layer is 0.010" thick Rogers RO3203,  $\epsilon_r = 3.02$ . Metal layers are 0.5-oz copper.

The pad pattern shown has been developed and tested for optimized assembly at TriQuint Semiconductor. The PCB land pattern has been developed to accommodate lead and package tolerances. Since surface mount processes vary from company to company, careful process development is recommended.

For further technical information, refer to the [TGA4539-SM](#) Product Information page.

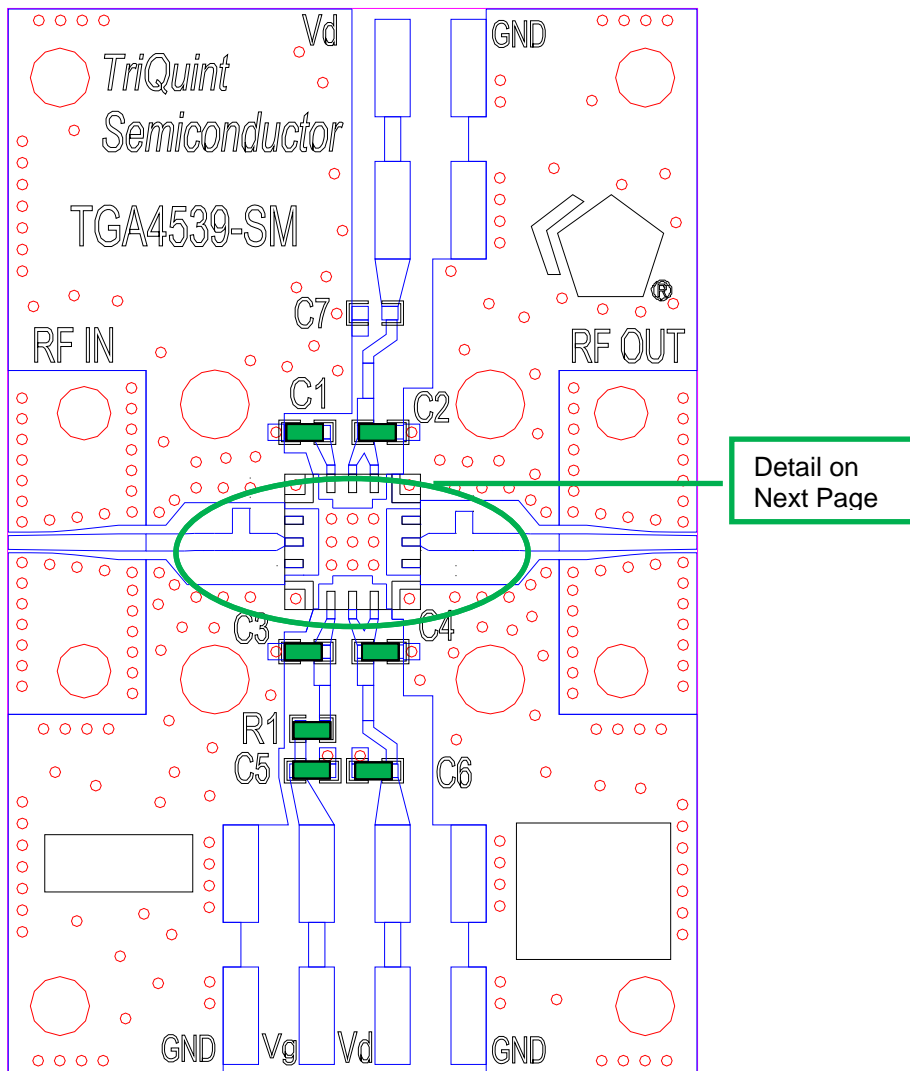

### Applications Information (cont.)

#### Bill of Material

Ref Des	Value	Description	Manufacturer	Part Number
C1- C4	100 pF	Cap, 0402, 50 V, 5%, COG	Various	
C5, C6, C7	1 uF	Cap, 0603, 25 V, 10%, X5R	Various	
R1	15 Ohms	Res, 0402, 0.1 W, SMD	Various	

#### PC Board Tuning Layout

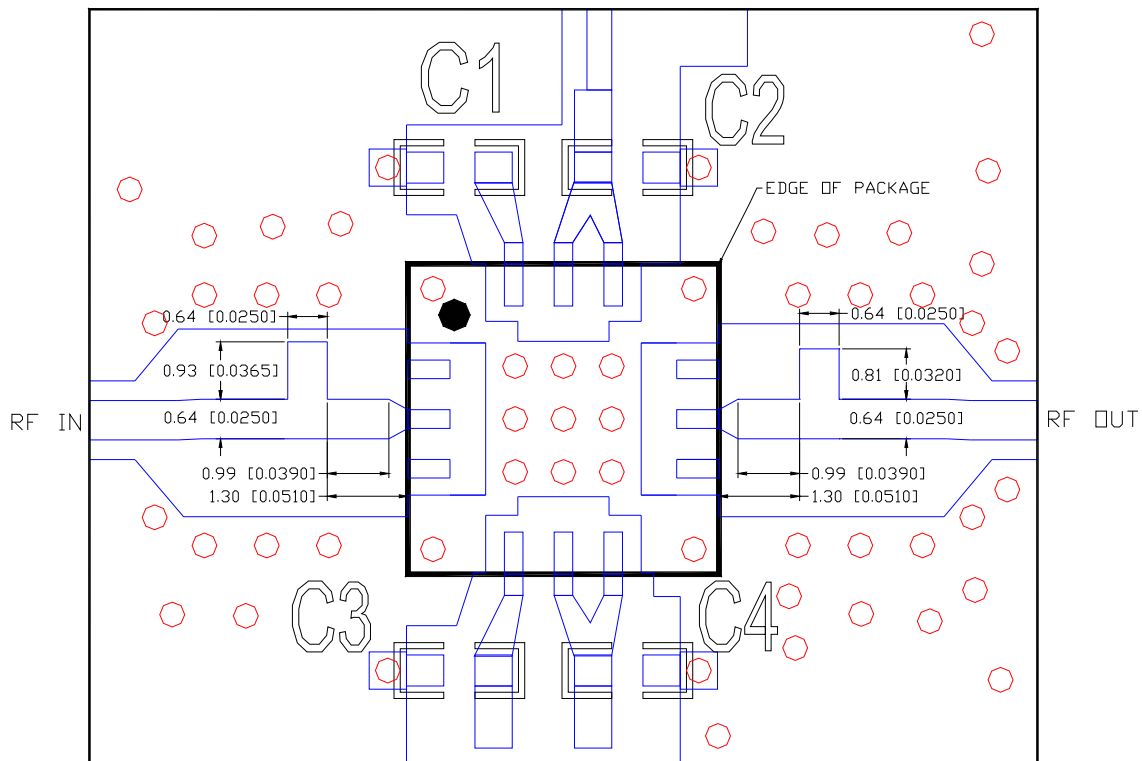

Dimensions are in millimeters [inches].

All performance data in this data sheet was measured using the transmission line tuning elements shown at pins 3 (RF In) and pin 13 (RF Out). These transmission line dimensions apply to transmission lines on 0.010" thick Rogers RO3203,  $\epsilon_r = 3.02$ .

## Mechanical Information

### Package Information and Dimensions

All dimensions are in millimeters.

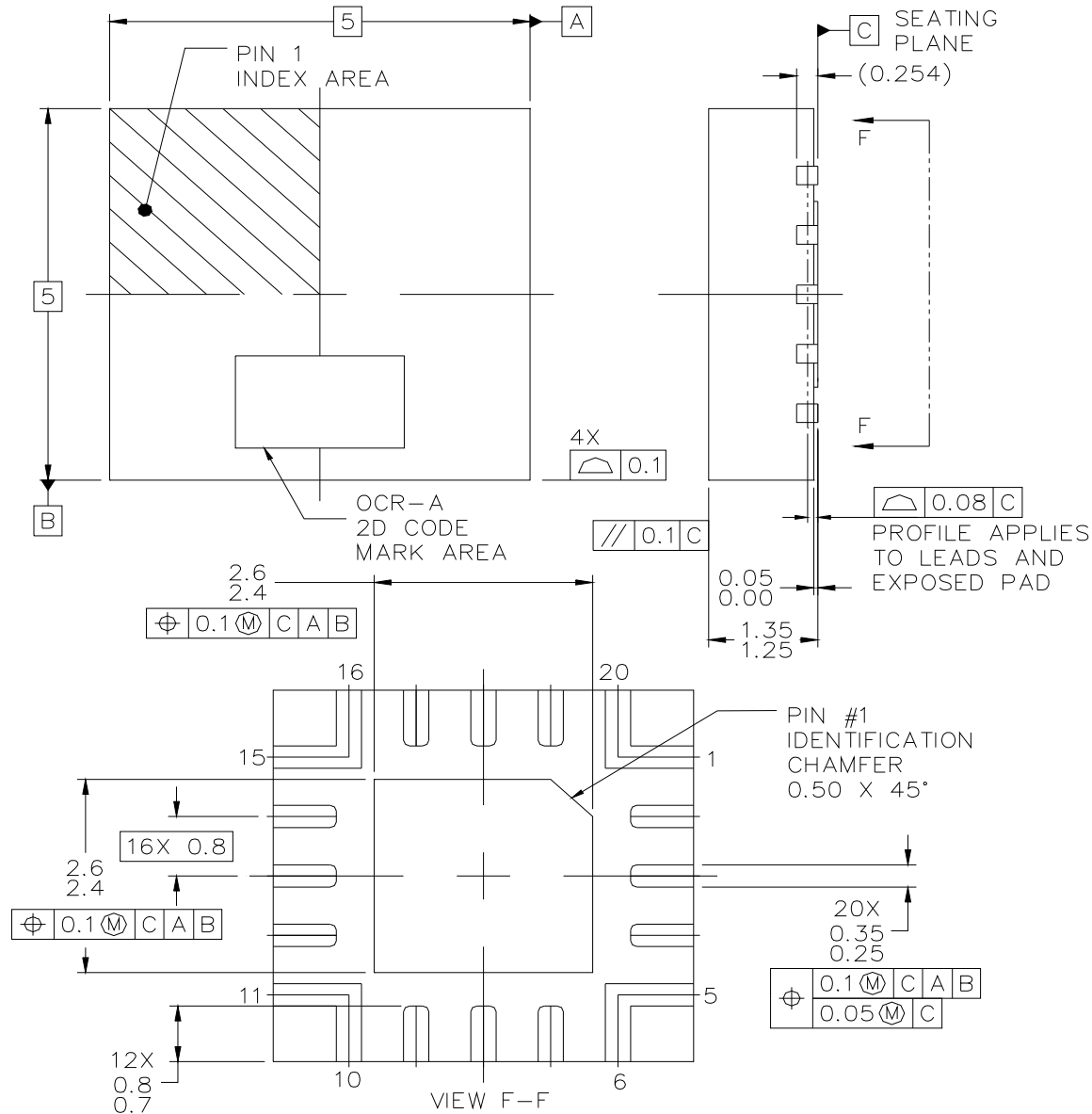

The TGA4539-SM will be marked with the “4539” designator and a lot code marked below the part designator. The “YY” represents the last two digits of the year the part was manufactured, the “WW” is the work week, and the “XXXX” is an auto-generated number. The OCR-A 2D Code has four rows and is the ‘XXXX number, one digit per row.

This package is lead-free/RoHS-compliant with a copper alloy base (CDA194), and the plating material on the leads is NiPdAu. It is compatible with both lead-free (maximum 260 °C reflow temperature) and tin-lead (maximum 245 °C reflow temperature) soldering processes.

## Mechanical Information (cont.)

### Mounting Configuration

All dimensions are in millimeters (inches).

Note:

Ground / thermal vias are critical for the proper performance of this device.  
 Vias have a final plated thru diameter of 0.406 mm (0.016").

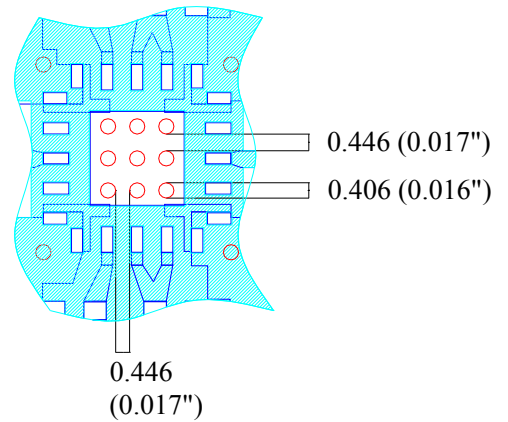

## Tape and Reel Information

Tape and reel specifications for this part are also available on the TriQuint website in the “Application Notes” section.  
 Standard T/R size = 500 pieces on a 7 x 0.5” reel.

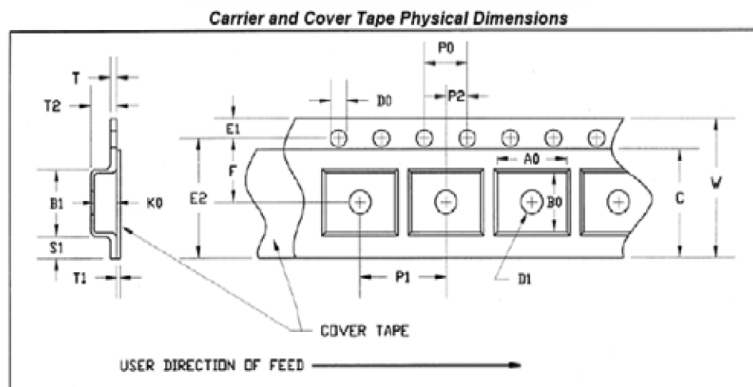

## CARRIER AND COVER TAPE DIMENSIONS

Part	Feature	Symbol	Size (in)	Size (mm)
Cavity	Length	A0	0.207	5.25
	Width	B0	0.207	5.25
	Depth	K0	0.043	1.80
	Pitch	P1	0.315	8.00
Distance Between Centerline	Cavity to Perforation Length Direction	P2	0.079	2.00
	Cavity to Perforation Width Direction	F	0.217	5.50
Cover Tape	Width	C	0.374	9.50
Carrier Tape	Width	W	0.472	12.00

## Product Compliance Information

### ESD Information



#### Caution! ESD-Sensitive Device

ESD Rating: 1A  
 Value: Passes  $\geq 250$  V min.  
 Test: Human Body Model (HBM)  
 Standard: JEDEC Standard JESD22-A114

### MSL Rating

Level MSL1 at +260 °C convection reflow  
 The part is rated Moisture Sensitivity Level MSL1 at 260°C per JEDEC standard IPC/JEDEC J-STD-020.

### ECCN

US Department of Commerce 3A001.b.2.c

### Solderability

Compatible with the latest version of J-STD-020, Lead free solder, 260°

This part is compliant with EU 2002/95/EC RoHS directive (Restrictions on the Use of Certain Hazardous Substances in Electrical and Electronic Equipment).

This product also has the following attributes:

- Lead Free
- Halogen Free (Chlorine, Bromine)
- Antimony Free
- TBBP-A ( $C_{15}H_{12}Br_4O_2$ ) Free
- PFOS Free
- SVHC Free

**Note:** Use No Clean Solder for soldering.

## Recommended Soldering Temperature Profile

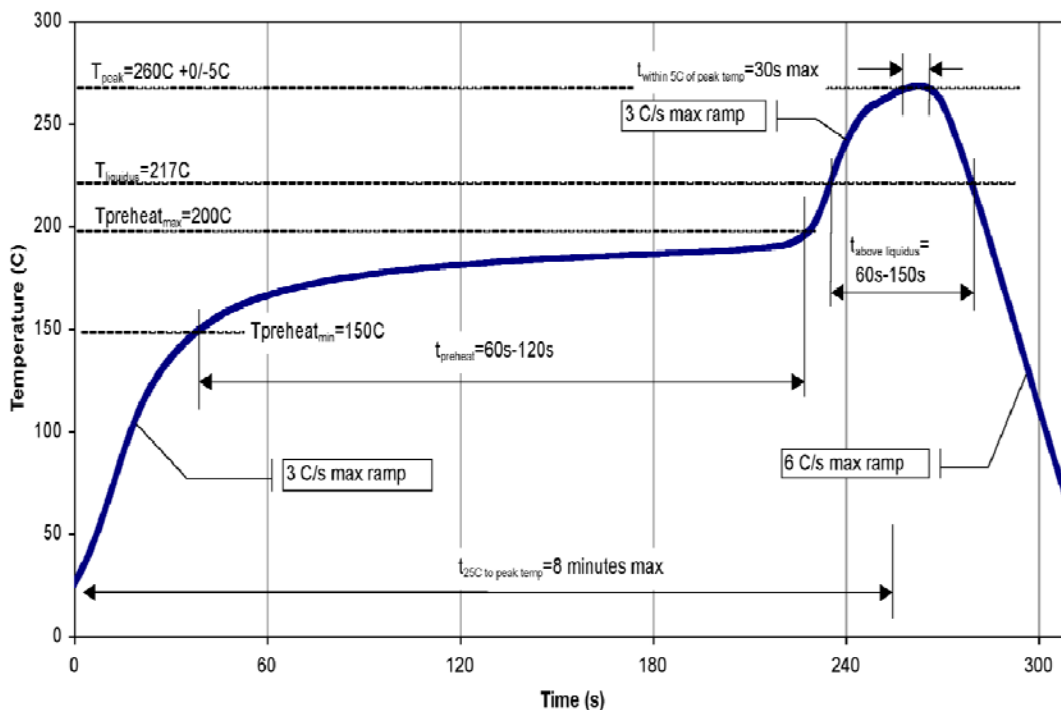

# TGA4539-SM

## Ka-Band 1 Watt Power Amplifier



### Contact Information

For the latest specifications, additional product information, worldwide sales and distribution locations, and information about TriQuint:

Web: [www.triquint.com](http://www.triquint.com)  
Email: [info-sales@tqs.com](mailto:info-sales@tqs.com)

Tel: +1.972.994.8465  
Fax: +1.972.994.8504

For technical questions and application information:

Email: [info-networks@tqs.com](mailto:info-networks@tqs.com)

### Important Notice

The information contained herein is believed to be reliable. TriQuint makes no warranties regarding the information contained herein. TriQuint assumes no responsibility or liability whatsoever for any of the information contained herein. TriQuint assumes no responsibility or liability whatsoever for the use of the information contained herein. The information contained herein is provided "AS IS, WHERE IS" and with all faults, and the entire risk associated with such information is entirely with the user. All information contained herein is subject to change without notice. Customers should obtain and verify the latest relevant information before placing orders for TriQuint products. The information contained herein or any use of such information does not grant, explicitly or implicitly, to any party any patent rights, licenses, or any other intellectual property rights, whether with regard to such information itself or anything described by such information.

TriQuint products are not warranted or authorized for use as critical components in medical, life-saving, or life-sustaining applications, or other applications where a failure would reasonably be expected to cause severe personal injury or death.