

9.9 - 12.5 Gb/s Optical Modulator Driver

TGA4954-SL

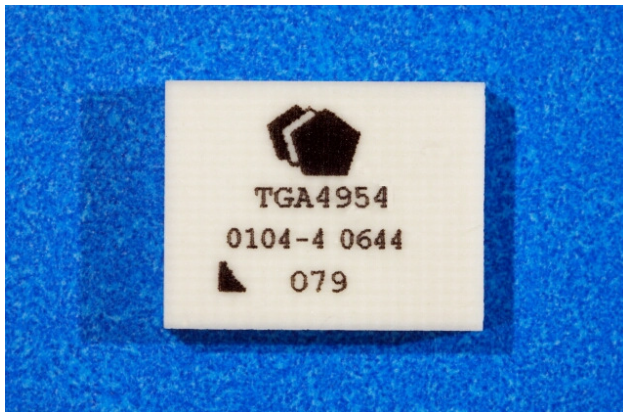

Product Description

The TriQuint TGA4954-SL is part of a series of surface mount modulator drivers suitable for a variety of driver applications and is compatible with Metro MSA standards.

The TGA4954-SL consists of two high performance wideband amplifiers combined with off chip circuitry assembled in a surface mount package. A single TGA4954-SL placed between the MUX and Optical Modulator provides OEMs with a board level modulator driver surface mount solution.

The TGA4954-SL provides Metro and Long Haul designers with system critical features such as: low power dissipation (1.1W at $V_o = 6V$), low rail ripple, high voltage drive capability at 5V bias (6 V amplitude adjustable to 3 V), low output jitter, and low input drive sensitivity (250mV at $V_o = 6V$).

The TGA4954-SL requires external DC blocks, a low frequency choke, and control circuitry.

Evaluation boards available upon request.

Lead Free finish & RoHS compliant.

Key Features and Performance

- Wide Drive Range (3V to 10V)
- Single-Ended Input/Output
- Low Power Dissipation
(1.1W @ 6Vo)
- Low Rail Ripple
- 25psec Edge Rates (20/80%)
- Hot-pluggable
- Package Dimensions:
11.4 x 8.9 x 2.0 mm
(0.450 x 0.350 x 0.080 inches)

Primary Applications

- Mach-Zehnder Modulator Driver

Measured Data

$V_{dd}=5V$; $I_{d1}=65mA$; $I_{d2T}=115mA$; $V_{ctrl1}=-0.2V$;
 $V_{ctrl2}=+0.2V$

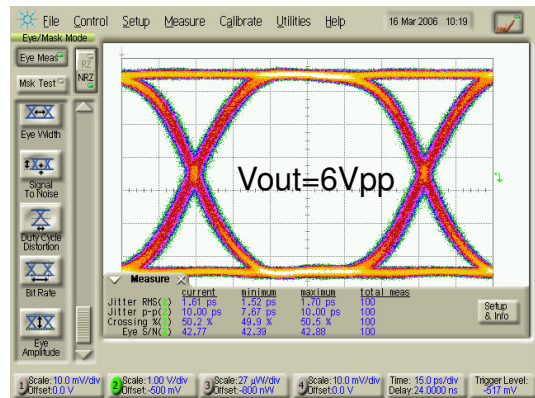
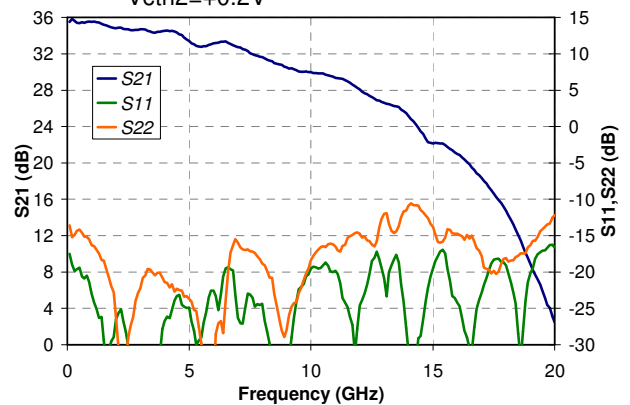

TABLE I
MAXIMUM RATINGS

Symbol	Parameter	Value	Notes
V_{D1} V_{D2T}	Drain Voltage	8 V	<u>1/</u> <u>2/</u>
V_{G1} V_{G2}	Gate Voltage Range	-3V to 0V	<u>1/</u>
V_{CTRL1} V_{CTRL2}	Control Voltage Range	-3V to V_D	<u>1/</u>
I_{D1} I_{D2T}	Drain Supply Current (Quiescent)	200 mA 350 mA	<u>1/</u> <u>2/</u>
$ I_{G1} $ $ I_{G2} $	Gate Supply Current	15 mA	<u>1/</u>
$ I_{CTRL1} $ $ I_{CTRL2} $	Control Supply Current	15 mA	<u>1/</u>
P_{IN}	Input Continuous Wave Power	23 dBm	<u>1/</u> <u>2/</u>
V_{IN}	12.5Gb/s PRBS Input Voltage	4 V_{PP}	<u>1/</u> <u>2/</u>
P_D	Power Dissipation	4 W	<u>1/</u> <u>2/</u> <u>3/</u>
T_{CH}	Operating Channel Temperature	150 °C	<u>4/</u>
T_M	Mounting Temperature (10-20 Seconds)	260 °C	
T_{STG}	Storage Temperature	-65 to 150 °C	

- 1/ These ratings represent the maximum operable values for this device
- 2/ Combinations of supply voltage, supply current, input power, and output power shall not exceed P_D at a package base temperature of 80°C
- 3/ When operated at this bias condition with a baseplate temperature of 80°C, the MTTF is reduced
- 4/ Junction operating temperature will directly affect the device median time to failure (MTTF). For maximum life, it is recommended that junction temperatures be maintained at the lowest possible levels.

TABLE II
THERMAL INFORMATION

Parameter	Test Conditions	T _{CH} (°C)	R _{θJC} (°C/W)	MTTF (hrs)
R _{θJC} Thermal Resistance (Channel to Backside of Package)	V _{DD} = 5V I _{DD} = 215mA P _{DISS} = 1.08W T _{BASE} = 70°C	92	20.4	>1E6

Note: Thermal transfer is conducted through the bottom of the TGA4954-SL package into the motherboard. The motherboard must be designed to assure adequate thermal transfer to the base plate.

TABLE III
RF CHARACTERIZATION TABLE
(T_A = 25°C, Nominal)

Parameter	Test Conditions	Min	Typ	Max	Units	Notes
Small Signal Bandwidth			8		GHz	
Saturated Power Bandwidth			12		GHz	
Small Signal Gain	0.1, 2, 4 GHz	28	34		align="center">dB	align="center"> <u>1/</u>
	6 GHz	26	33			
	10 GHz	24	30			
	14 GHz	17	25			
	16 GHz	12	21			
Input Return Loss	0.1, 2, 4, 6, 10, 14, 16 GHz	10	15		dB	<u>1/</u>
Output Return Loss	0.1, 2, 4, 6, 10, 14, 16 GHz	10	15		dB	<u>1/</u>
Noise Figure	3 GHz		2.5		dB	
Small Signal AGC Range	Midband		28		dB	
Saturated Output Power	2, 4, 6, 8 & 10 GHz	24	26.5		dBm	<u>4/ 5/</u>

TABLE III (Continued)
RF CHARACTERIZATION TABLE
(T_A = 25°C, Nominal)

Parameter	Test Conditions	Min	Typ	Max	Units	Notes
Eye Amplitude	V _{D2} = 8.0V V _{D2} = 6.5V V _{D2} = 5.5V V _{D2} = 4.5V V _{D2} = 4.0V	9.0 7.0 6.0 5.5 5.0			V _{PP}	<u>2/</u>
Additive Jitter (RMS)	V _{IN} = 500mV _{PP} V _{IN} = 800mV _{PP}		1.2 1.4	3.0 3.0	psec	<u>3/</u>
Q-Factor	V _{IN} = 500mV _{PP} V _{IN} = 800mV _{PP}	25 25	42 42		V/V	
Delta Eye Amplitude	800mV _{PP}	-0.50	0.0	0.50	V _{PP}	
Delta Crossing Percentage	500–800 mV _{in p-p}	-8		8	%	

Table III Notes:

- 1/ Typical Package RF Bias Conditions: V_{DD} = 5V, adjust V_{G1} to achieve I_{D1} = 65mA then adjust V_{G2} to achieve I_{D2T} = 115mA – 155 mA (I_{DD} = 180 – 220 mA), V_{CTRL1} = -0.2V & V_{CTRL2} = +0.2 V
- 2/ V_{IN} = 250mV, Data Rate = 10.7Gb/s, V_{D1} = V_{D2T} or greater, V_{CTRL2} and V_{G2} are adjusted for maximum output. Typical final I_{DD} under drive ~ 220 mA.
- 3/ Computed using RSS Method where $J_{RMS_DUT} = \sqrt{(J_{RMS_TOTAL}^2 - J_{RMS_SOURCE}^2)}$
- 4/ Verified at die level on-wafer probe
- 5/ Power Bias Die Probe: V_{TEE} = 8V, adjust V_G to achieve I_{DD} = 175mA ±5%, V_{CTRL} = +1.5V

Note: At the die level, drain bias is applied through the RF output port using a bias tee, voltage is at the DC input to the bias tee

Measured Data

Vdd=5V; Id1=65mA; Id2=115mA; Vctrl1=-0.2V; Vctrl2=+0.2V

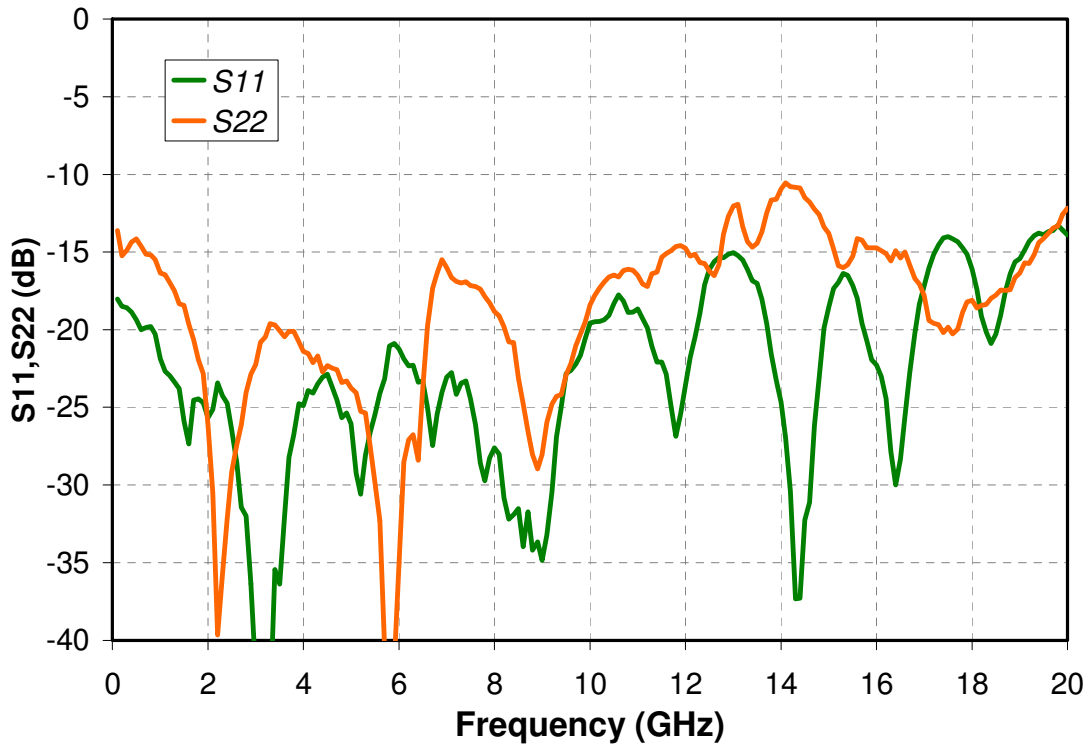
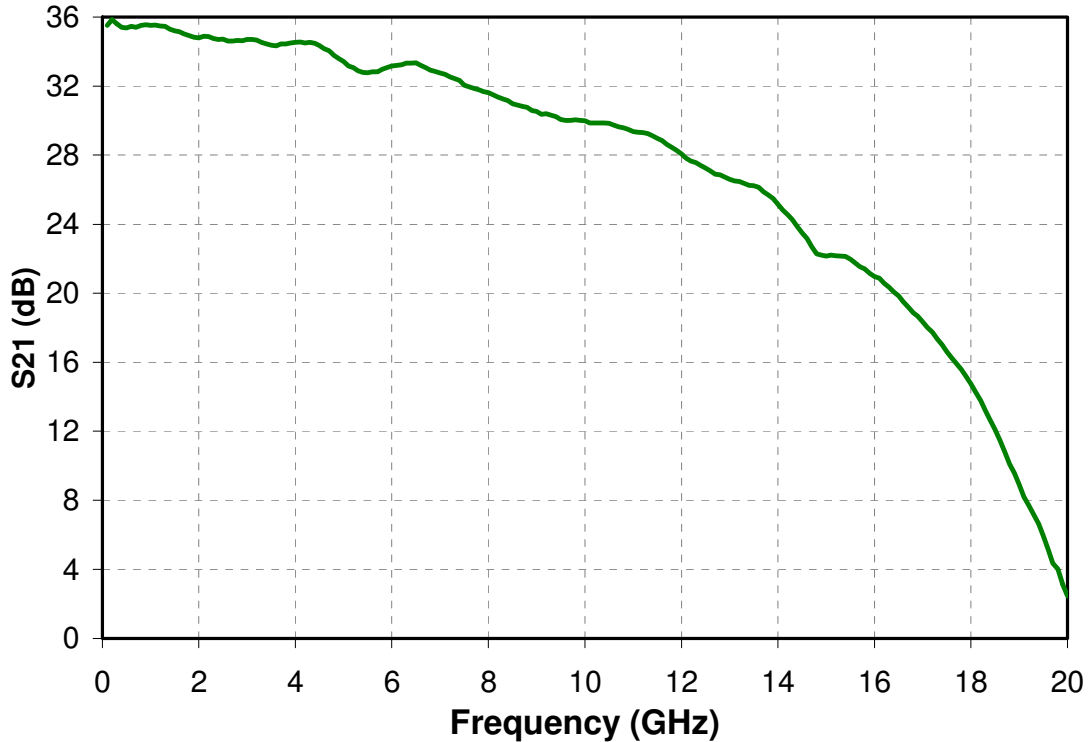

**TGA4954-SL Typical Performance Data
is measured in a Test Fixture**

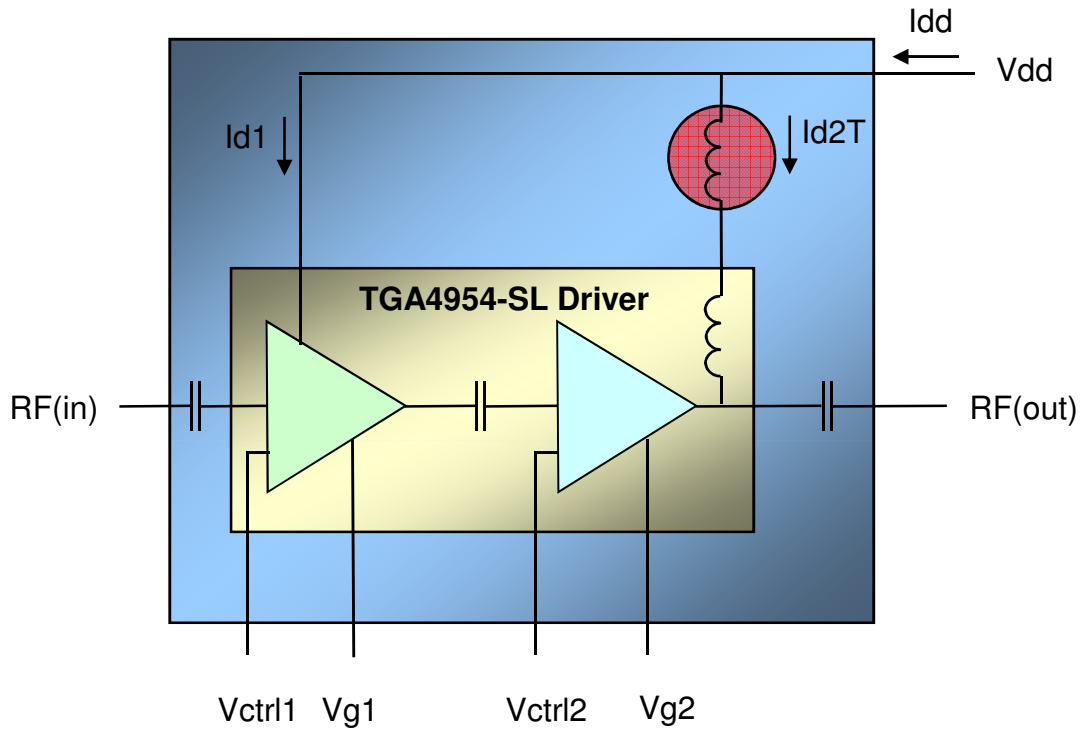

Test Fixture Block Diagram

Measured Data

Vdd=5V; Id1=65mA; Vctrl1=-0.2V; Vin=500mVpp; Vo=6Vpp
 Vg2 & Vctrl2 are varied to achieve 6Vo & 50% crossing

9.953Gbps

10.7Gbps

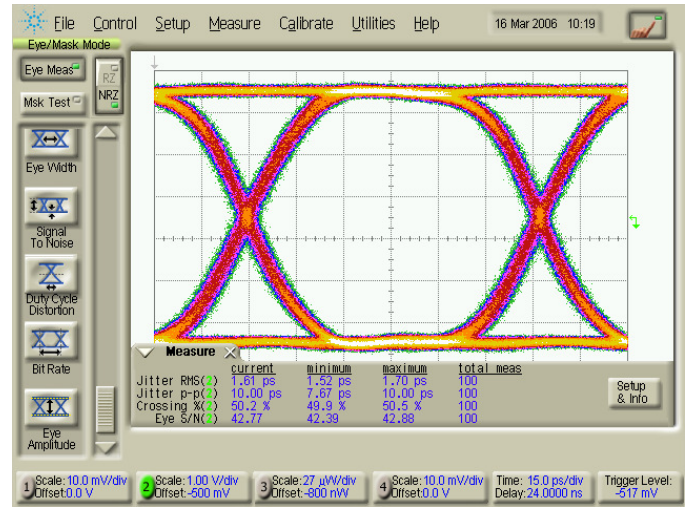
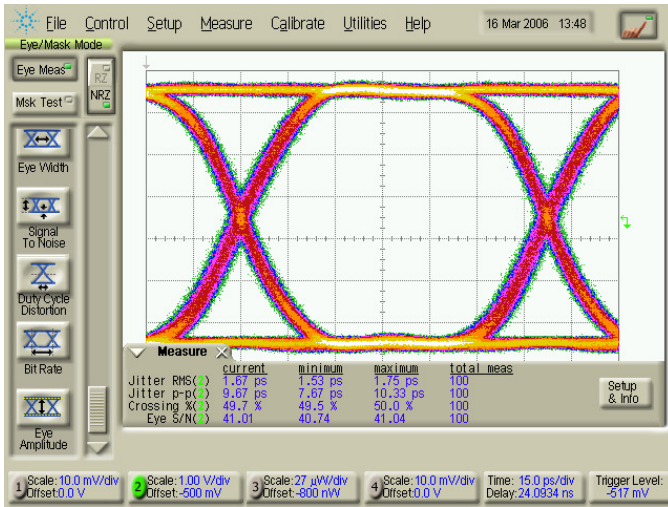

11.3Gbps

12.5Gbps

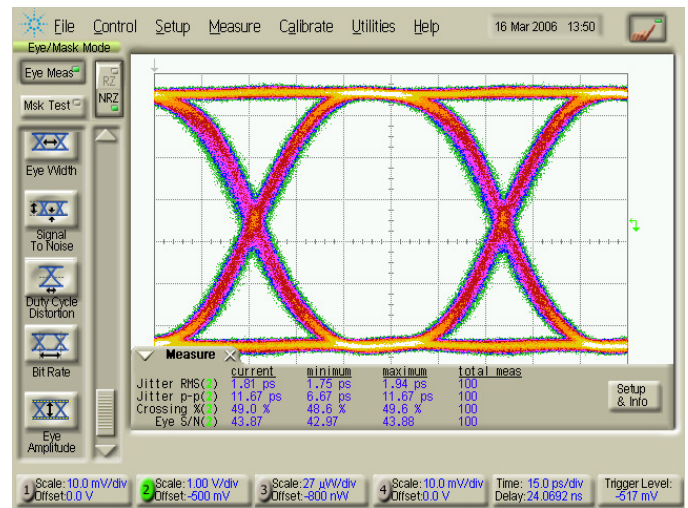
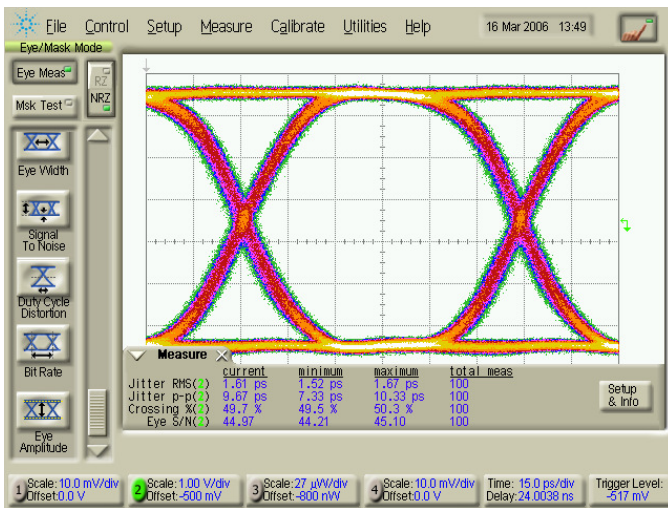

Measured Data

Vdd=5V; Id1=65mA; Vctrl1=-0.2V; Vo=6Vpp; 10.7Gbps
 Vg2 & Vctrl2 are varied to achieve 6Vo & 50% crossing

Vin=250mVpp

Vin=500mVpp

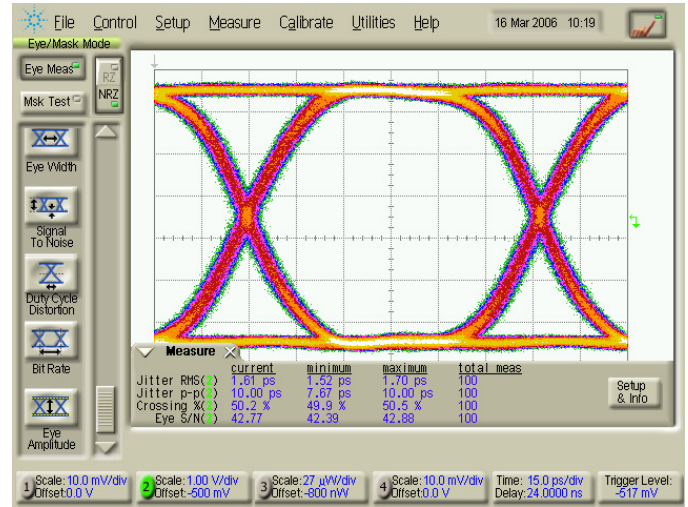
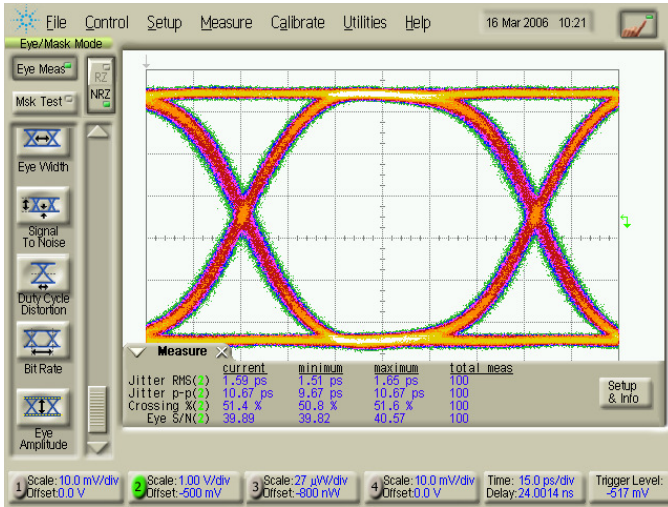

Vin=800mVpp

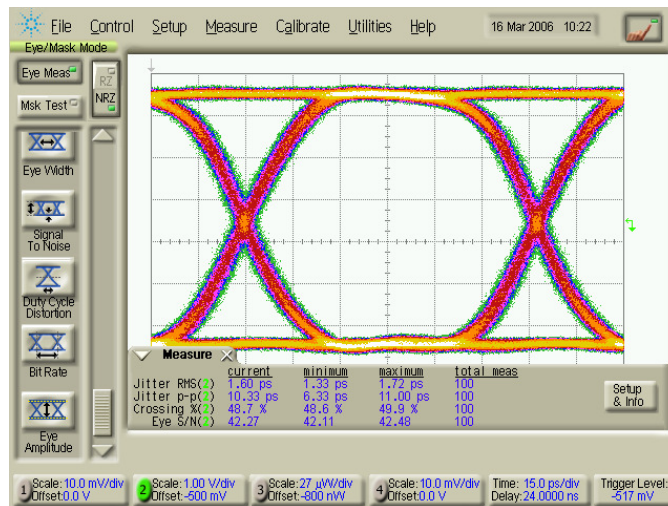

Measured Data

Vdd=5V; Id1=65mA; Vctrl1=-0.2V; Vin=500mVpp; 10.7Gbps
 Vg2 & Vctrl2 are varied to achieve 6Vo & 50% crossing

3Vo

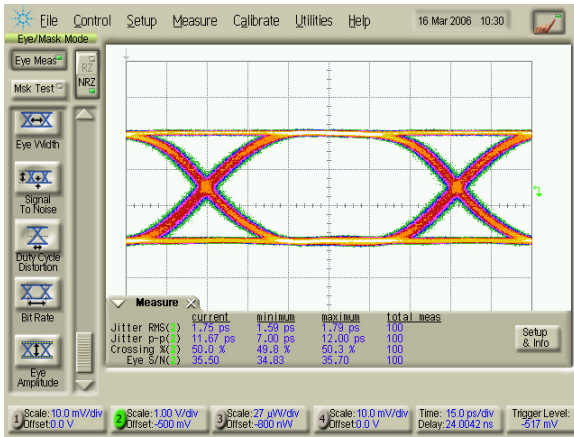

4Vo

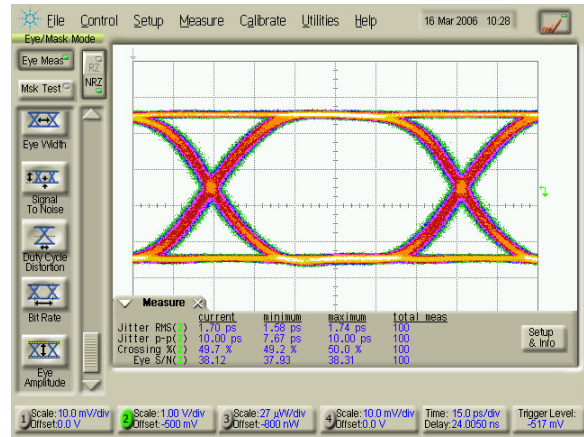

5Vo

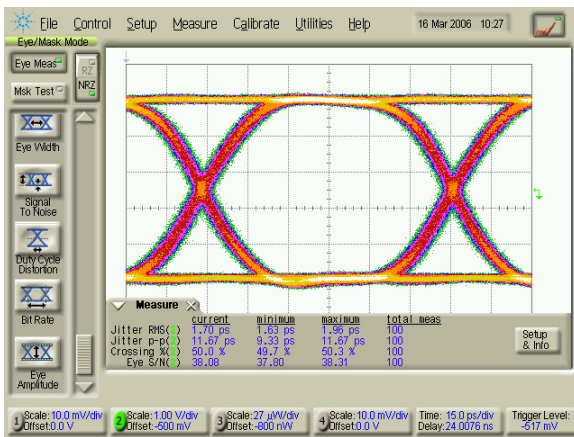

6Vo

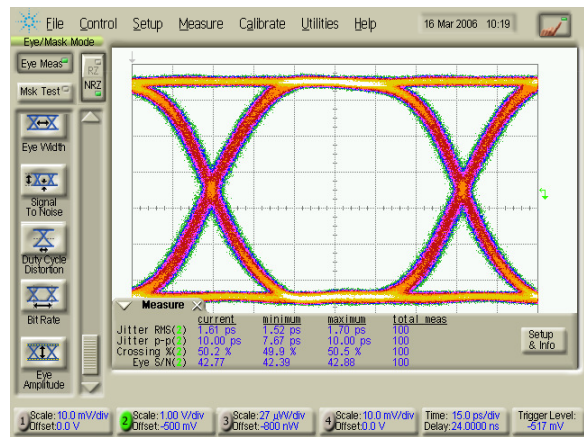

Input

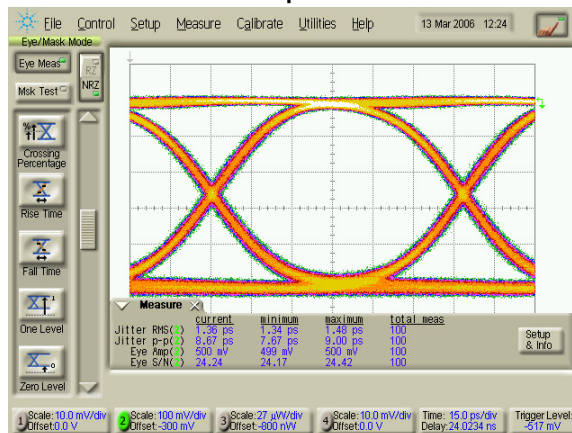

Production - Initial Alignment - Bias Procedure
Vdd=5V, Vo=6Vamp, CPC=50%
(Hot-Pluggable)

Bias Network Initial Conditions -

Vg1=-1.5V
Vg2=-1.5V
Vctrl1=-0.2V
Vctrl2=+.1V
Vdd=5V

Bias ON

1. Disable the output of MUX
2. Apply Vg1, Vg2, Vctrl1 and Vctrl2 in any sequence.
3. Apply Vdd.
4. Make Vg1 more positive until **Idd=65mA**.
 - This is Id1 (current into the first stage)
 - Typical value for **Vg1 is -0.65V**
5. Make Vg2 more positive until Idd=180 – 220 mA.
 - This sets Id2T to 115 – 155 mA.
 - Typical value for Vg2 is -0.55V
6. Enable the output of the MUX.
 - Set Vin=500mV
7. Output Swing Adjust: Adjust Vctrl2 slightly positive to increase output swing or adjust Vctrl2 slightly negative to decrease the output swing.
 - Typical value for **Vctrl2 is +0.22V** for Vo=6V.
8. Crossover Adjust: Adjust Vg2 slightly positive to push the crossover down or adjust Vg2 slightly negative to push the crossover up.
 - Typical value for **Vg2 is -0.57V** to center crossover with Vo=6V.

Bias OFF

1. Remove Vdd.
2. Remove Vg1, Vg2, Vctrl1 and Vctrl2 in any sequence.

General Comments for Production Operation of TGA4954-SL:

1. Due to natural variations in gate voltages observed with GaAs FET amplifiers used internally to the TGA4954-SL, optimal eye performance is obtained when the gate voltages (Vg1 and Vg2) are set to control desired drain currents (Id1 and Id2T)
2. Vc2 feedback circuit recommended for output amplitude correction.

Production - Post Alignment - Bias Procedure
Vdd=5V, Vo=6Vamp, CPC=50%
(Hot-Pluggable)

Bias Network Initial Conditions -

Vg1= As found during initial alignment
Vg2=-As found during initial alignment
Vctrl1=-0.2V
Vctrl2=As found during initial alignment
Vdd=5V

Bias ON

1. Mux output can be either Enabled or Disabled
2. Apply Vg1, Vg2, Vctrl1 and Vctrl2 in any sequence.
3. Apply Vdd.
4. Enable the output of the MUX
5. Output Swing Adjust: Adjust Vctrl2 slightly positive to increase output swing or adjust Vctrl2 slightly negative to decrease the output swing.
6. Crossover Adjust: Adjust Vg2 slightly positive to push the crossover down or adjust Vg2 slightly negative to push the crossover up.

Bias OFF

1. Remove Vdd.
2. Remove Vg1, Vg2, Vctrl1 and Vctrl2 in any sequence.

General Comments for Production Operation of TGA4954-SL:

1. Due to natural variations in gate voltages observed with GaAs FET amplifiers used internally to the TGA4954-SL, optimal eye performance is obtained when the gate voltages (Vg1 and Vg2) are set to control desired drain currents (Id1 and Id2T)
2. Vc2 feedback circuit recommended for output amplitude correction.

Mechanical Drawing

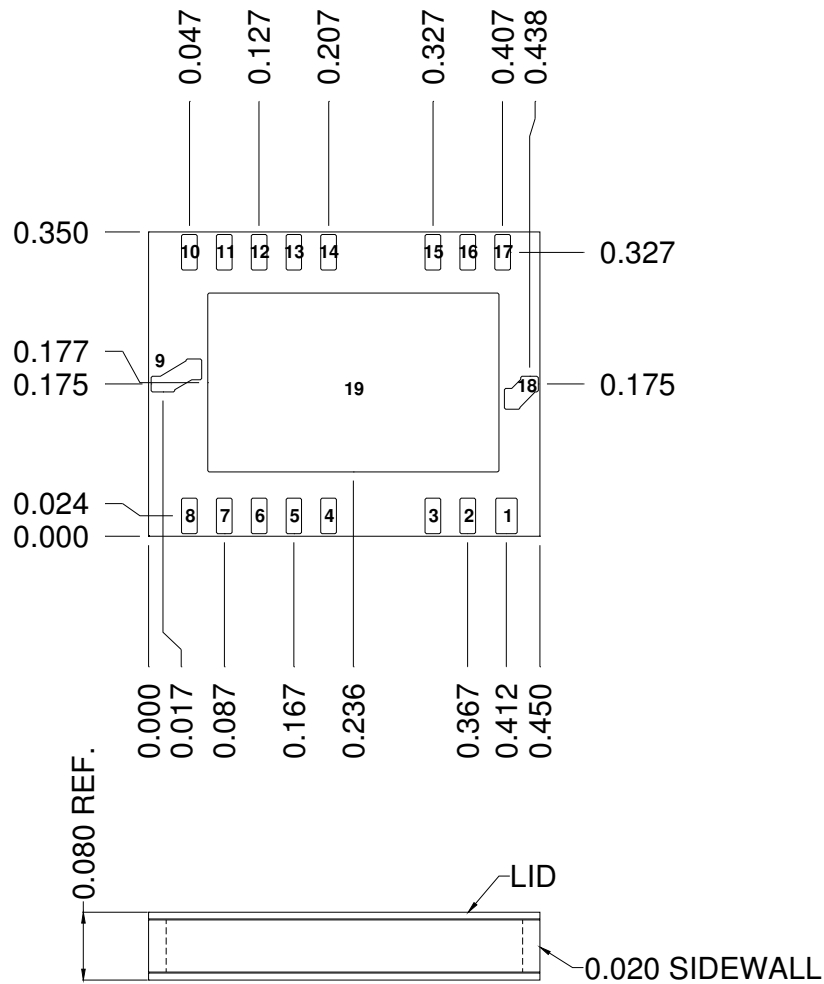

Bond Pad #1	N/C	0.025 x 0.041	Bond Pad #10	N/C	0.018 x 0.041
Bond Pad #2	N/C	0.018 x 0.041	Bond Pad #11	N/C	0.018 x 0.041
Bond Pad #3	Vg1	0.018 x 0.041	Bond Pad #12	Vd2T	0.018 x 0.041
Bond Pad #4	N/C	0.018 x 0.041	Bond Pad #13	N/C	0.018 x 0.041
Bond Pad #5	N/C	0.018 x 0.041	Bond Pad #14	Vctrl2	0.018 x 0.041
Bond Pad #6	Vg2	0.018 x 0.041	Bond Pad #15	Vd1	0.018 x 0.041
Bond Pad #7	N/C	0.018 x 0.041	Bond Pad #16	N/C	0.018 x 0.041
Bond Pad #8	N/C	0.018 x 0.041	Bond Pad #17	Vctrl1	0.018 x 0.041
Bond Pad #9	RF Out	0.027 x 0.018	Bond Pad #18	RF In	0.020 x 0.018
			Bond Pad #19	GND	0.335 x 0.206

Note for Pin 13: Pin 13 can be soldered to the PCB but MUST be left electrically open.

Application Circuit

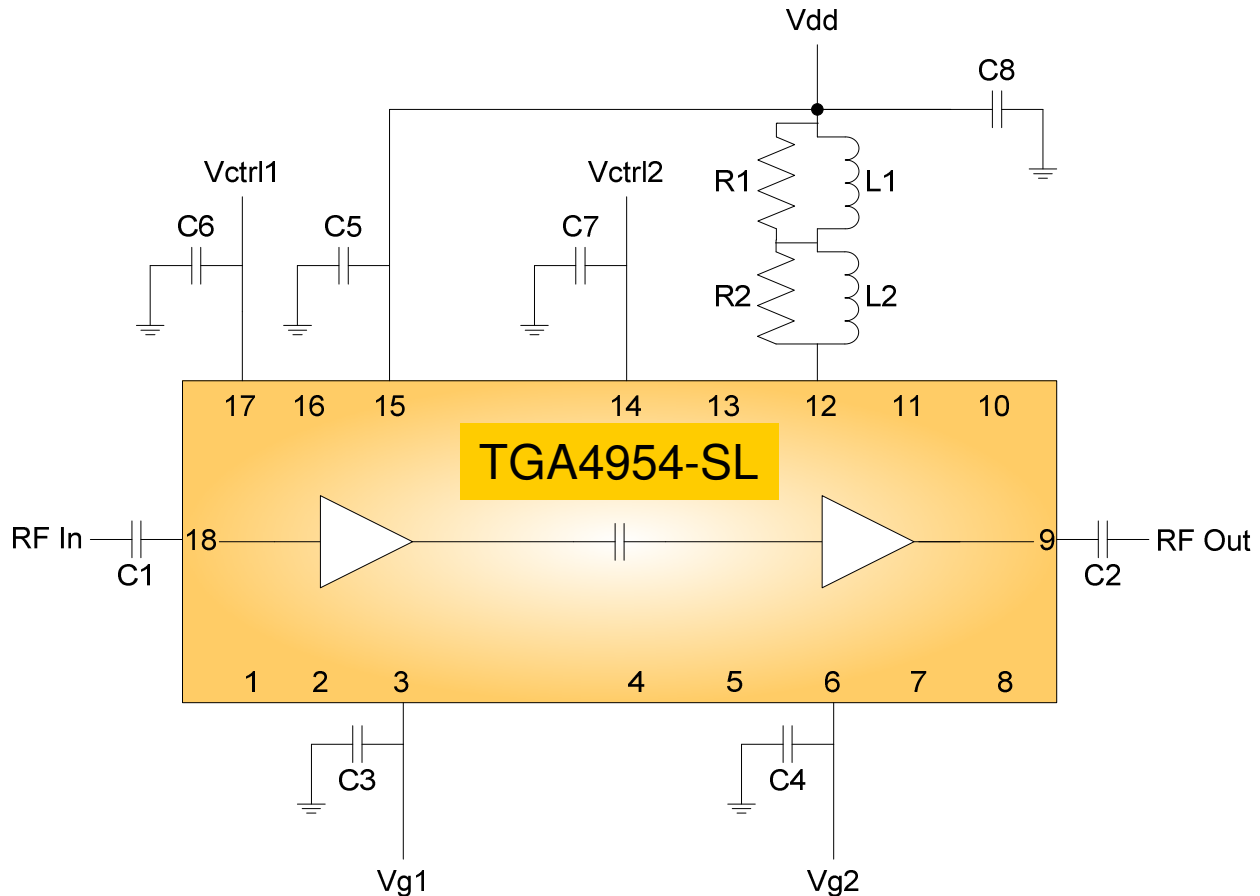

Recommended Components:

DESIGNATOR	DESCRIPTION	MANUFACTURER	PART NUMBER
C1, C2	DC Block, Broadband	Presidio	BB0502X7R104M16VNT9820
C3, C4, C5	10uF Capacitor MLC Ceramic	AVX	0802YC106KAT
C6, C7	0.01 uFCapacitor MLC Ceramic	AVX	0603YC103KAT
C8	10 uF Capacitor Tantalum	AVX	TAJA106K016R
L1	220 uH Inductor	Panasonic or Belfuse	ELLCTV221M S581-4000-14
L2	330 nH Inductor	Panasonic	ELJ-FAR33MF2
R1, R2	274 Ω Resistor	Panasonic	ERJ-2RKF2740X

Notes:

1. C3 and C4 extend low frequency performance thru 30 KHz. For applications requiring low frequency performance thru 100 kHz, C3 and C4 may be omitted
2. C6 and C7 are power supply decoupling capacitors and may be omitted when driven directly with an op-amp. Impedance looking into VCTRL1 and VCTRL2 is 10kΩ real

Assembly Notes

- Proper ESD precautions must be followed while handling parts.
- Parts must be in dry condition prior to soldering. See shipping label instructions.
- TGA4954-SL may be processed using conventional SMT processes.
- Both, lead-free and leaded solders may be used while maintaining following limits:
 - Maximum temperature 260°C
 - Total time above 220°C 60 seconds
 - Maximum ramp rate 3°C/second
 - Time within 5 °C of Peak Temperature10 – 20 sec max
- Typical solder reflow profiles are shown in figures below.
- Hand soldering is not recommended. Solder paste may be applied using a stencil printer or dot placement. The volume of solder paste depends on PCB and component layout and should be well controlled to ensure consistent mechanical and electrical performance.
- TGA4954-SL may be removed from circuit board and re-soldered once. After removal, solder pads must be leveled and cleaned. Prior to re-soldering, the part must be dried in accordance with shipping label instructions.

Solder reflow profiles for lead-free solders

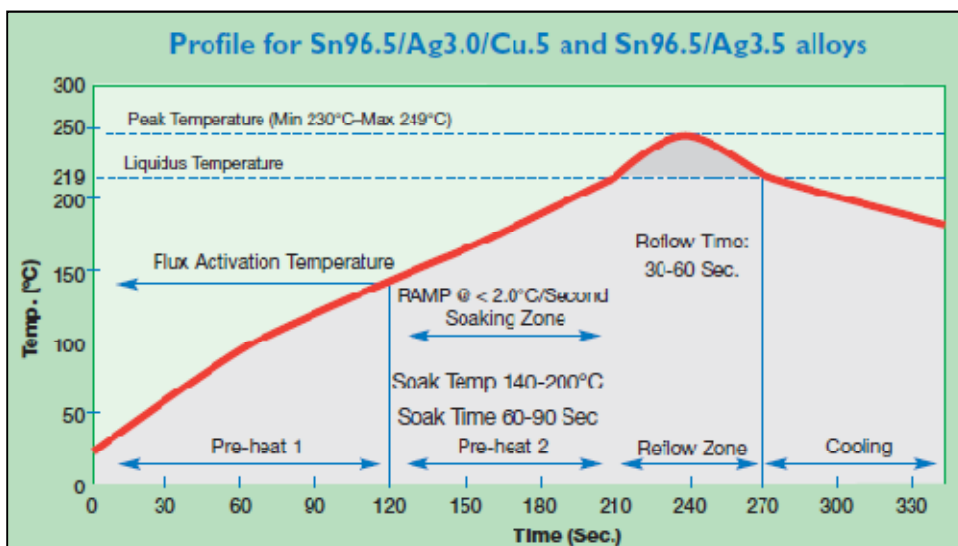
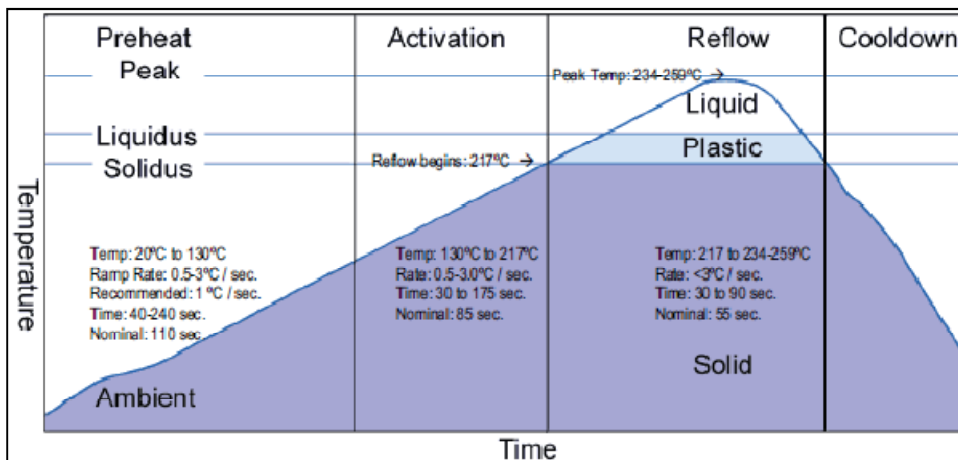

Solder reflow profiles for Sn63/Pb37 and Sn62/Pb36/Ag2 solders

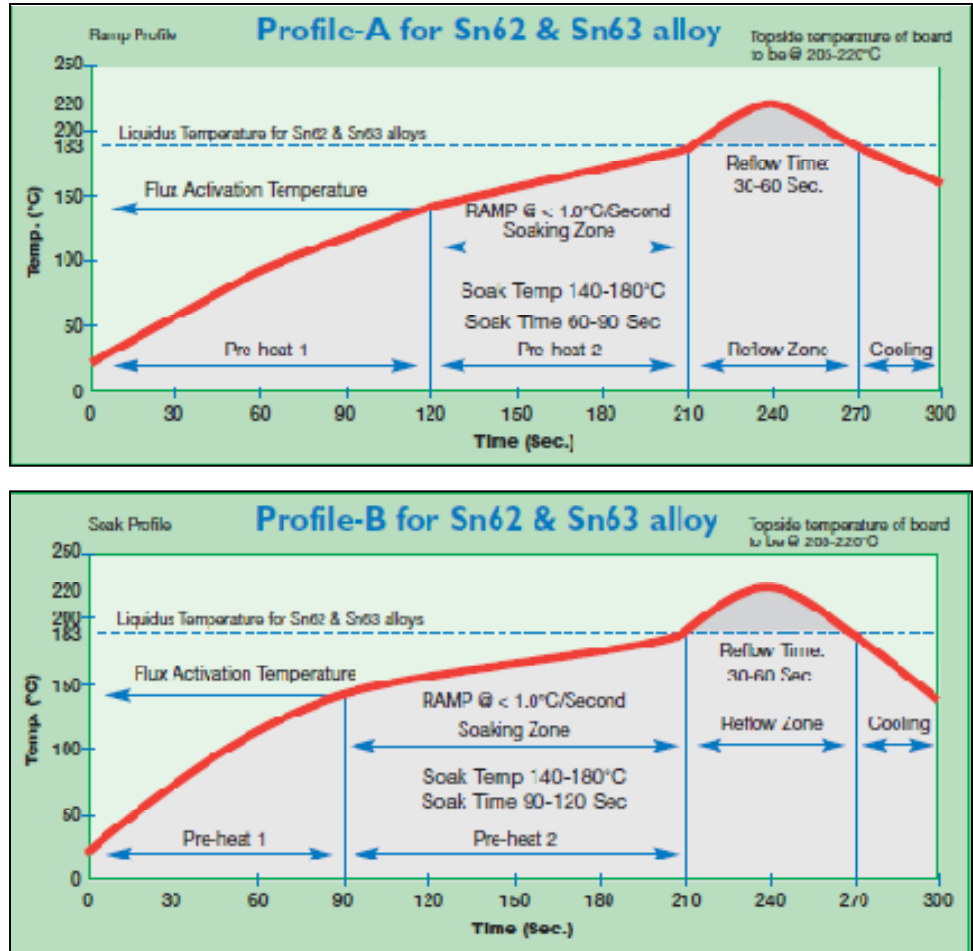

Environmental Ratings

Moisture Sensitivity Rating	ESD Rating
MSL3	1B

Ordering Information

Part	Package Style
TGA4954-SL	Land Grid Array, Surface Mount (RoHS)

GaAs MMIC devices are susceptible to damage from Electrostatic Discharge. Proper precautions should be observed during handling, assembly and test.