

# High Power Ka-Band Absorptive SPDT Switch

# TGS4304

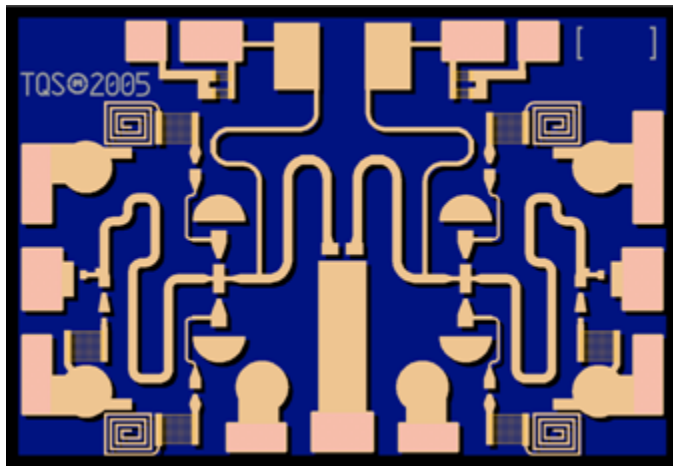

## Key Features and Performance

- 32 - 40 GHz Frequency Range
- > 33 dBm Input P1dB @  $V_C = +10V$
- On Chip Biasing Resistors
- On Chip DC Blocks
- < 1.0 dB Midband Insertion Loss
- < 4ns Switching Speed
- VPIN Technology
- Chip Dimensions:  
1.58 x 1.10 x 0.10 mm  
(0.043 x 0.062 x 0.004 inches)

## Description

The TriQuint TGS4304 is a GaAs absorptive single-pole, double-throw (SPDT) PIN monolithic switch designed to operate over the Ka-Band frequency range. This switch maintains a low insertion loss with high power handling of 33dBm or greater input P1dB at  $V_C = +10V$ . These advantages, along with the small size of the chip, make the TGS4304 ideal for use in communication and transmit/receive applications.

The TGS4304 is 100% DC & RF tested on-wafer to ensure performance compliance.

Lead free and RoHS compliant.

## Primary Applications

- Ka-Band Transmit / Receive
- Point-to-Point Radio
- Point-to-Multipoint Radio

## Measured Data

$V_A = +5V$ ,  $I_A \approx 0mA$ ,  $V_B = -4V$ ,  $I_B = 30mA$

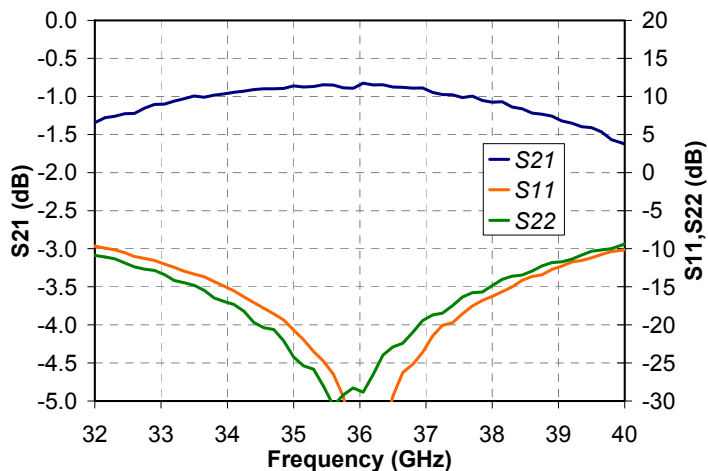

*Note: This device is early in the characterization process prior to finalizing all electrical test specifications. Specifications are subject to change without notice.*

**TABLE I  
MAXIMUM RATINGS**

Symbol	Parameter 1/	Value	Notes
V <sub>C</sub>	Control Voltage	-5V to +25V	2/
I <sub>C</sub>	Control Current	34 mA	<u>2/</u>
P <sub>IN</sub>	Input Continuous Wave Power	35 dBm	
T <sub>M</sub>	Mounting Temperature (30 Seconds)	320 °C	
T <sub>STG</sub>	Storage Temperature	-65 to 150 °C	

1/ These ratings represent the maximum operable values for this device.

2/ V<sub>C</sub> and I<sub>C</sub> are per bias pad.

3/ Operation above 30dBm requires control voltages above +7.5V.

**TABLE II  
RF CHARACTERIZATION TABLE  
(T<sub>A</sub> = 25°C, Nominal)  
(V<sub>A</sub> = +5V, I<sub>A</sub> = 0mA, V<sub>B</sub> = -4V, I<sub>B</sub> = 30mA)**

Symbol	Parameter	Test Conditions	Typ	Units	Notes
IL	Insertion Loss	F = 32 – 34 GHz F = 34 – 37 GHz F = 37 – 40 GHz	1.3 0.9 1.3	dB	
RL	Return Loss	F = 32 – 40 GHz	10	dB	
P1dB	Output Power @ 1dB Gain Compression	V <sub>C</sub> = +5 V V <sub>C</sub> = +7.5 V V <sub>C</sub> = +10 V V <sub>C</sub> = +20 V	31 33 34 34.5	dBm	<u>1/</u>

Note: Table II Lists the RF Characteristics of typical devices as determined by fixtured measurements.

1/ Frequency = 30GHz

**TABLE III  
TRUTH TABLE**

Selected RF Output	V <sub>A</sub>	V <sub>B</sub>
RF Out A	≥ +5V @ ~0mA	-4V @ 30mA
RF Out B	-4V @ 30mA	≥ +5V @ ~0mA

Selected RF Output	I <sub>A</sub>	I <sub>B</sub>
RF Out A	≥ +5V @ ~0mA	30mA
RF Out B	30mA	≥ +5V @ ~0mA

Operation at RF power levels >30 dBm requires increasing the positive voltage level to put a larger reverse bias on the diodes while the negative voltage level remains at -4V with a current of approximately 30mA. If you are using -5V, use alternate assembly with off chip resistors.

Bond pads IA and IB bypass the on-chip series resistors to allow adjustment of the current to the diodes in their forward biased state.

**Measured Performance  
On State**

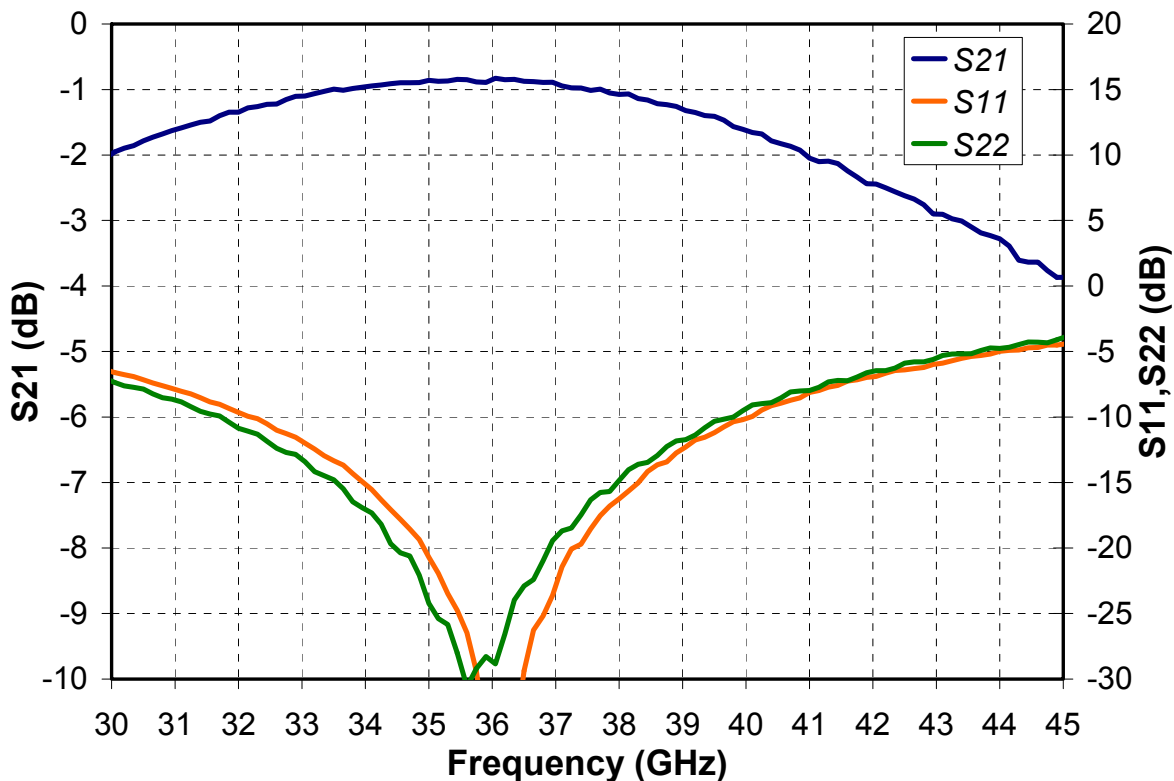

**Off State**

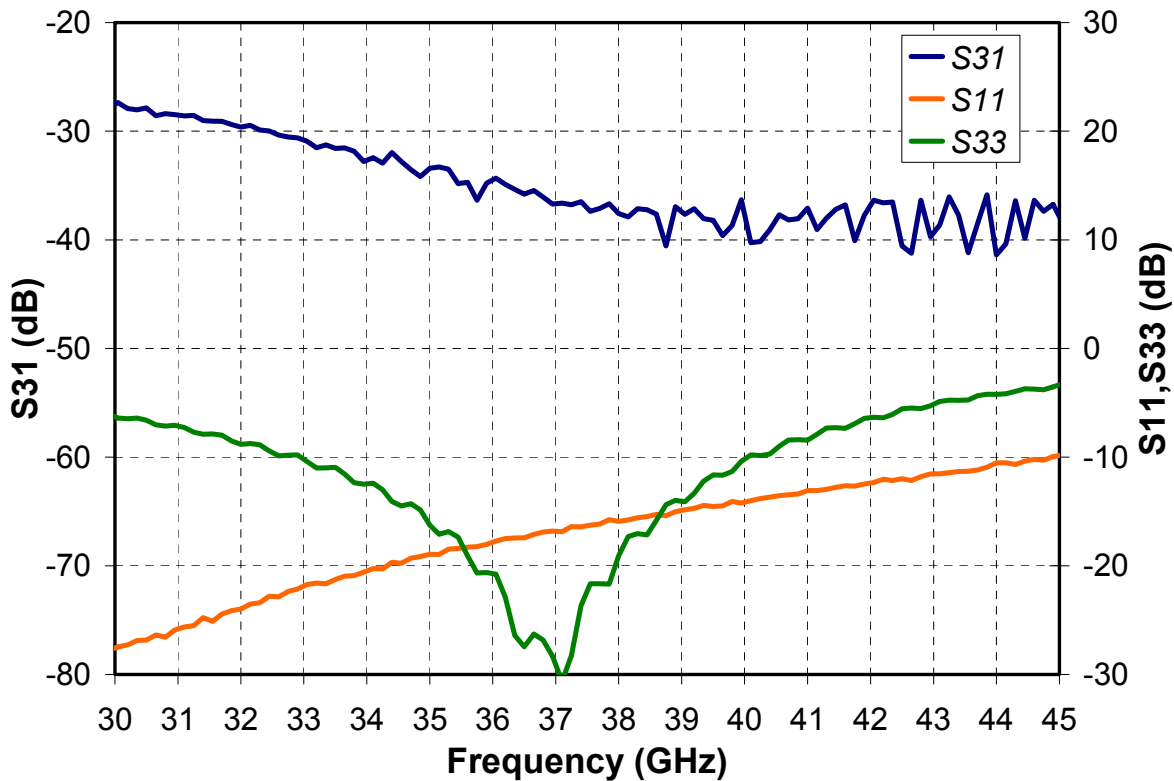

**Measured Performance**  
**30 GHz**

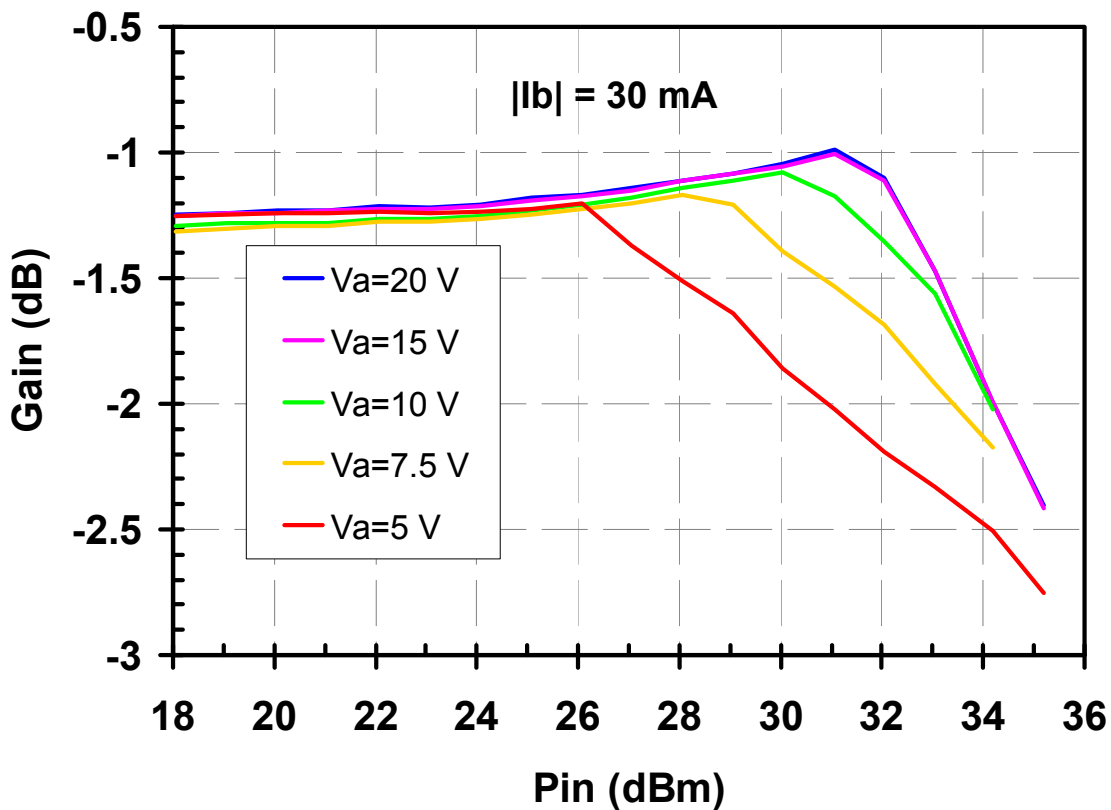

**Measured Performance  
On State**

**TGS4304**

Measurements include connector / fixture losses of ~ 1dB

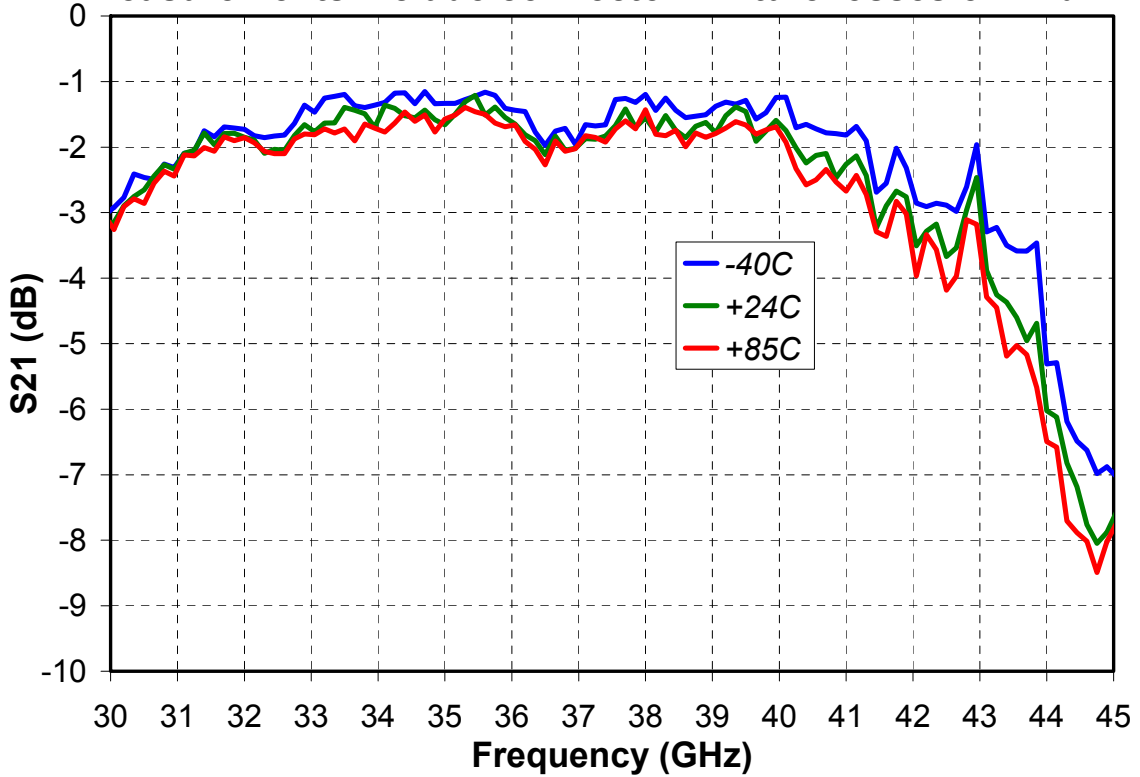

**Off State**

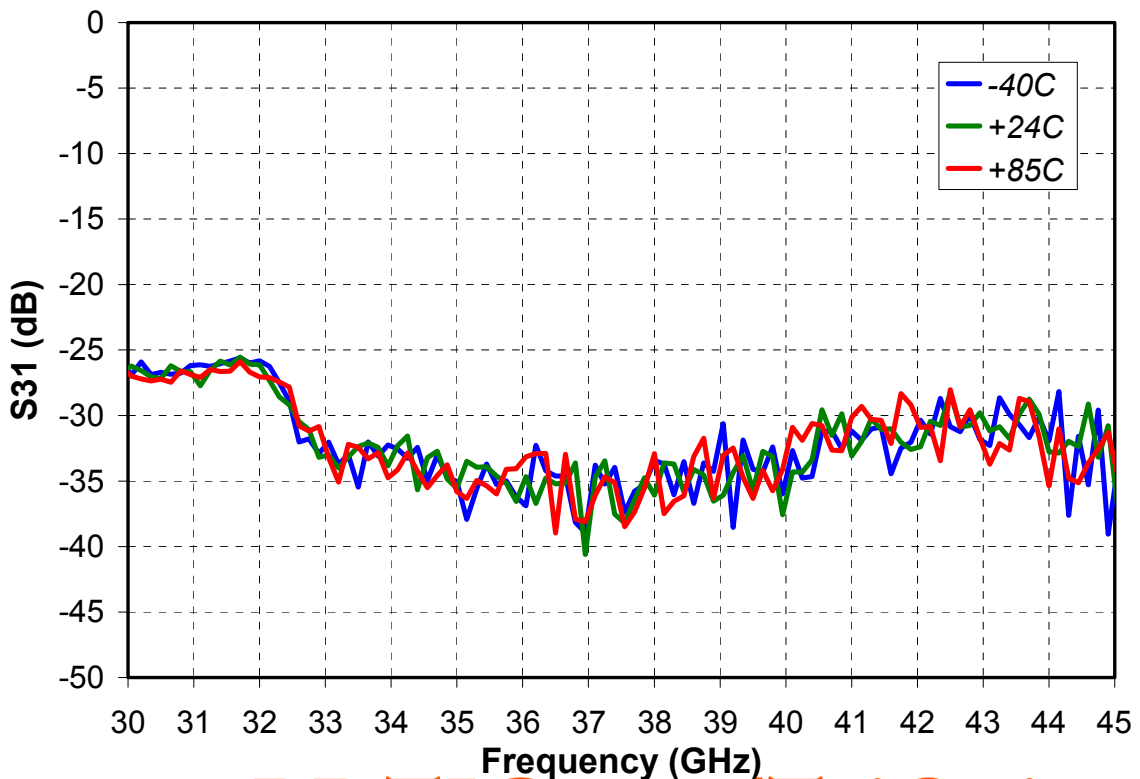

**Mechanical Drawing**

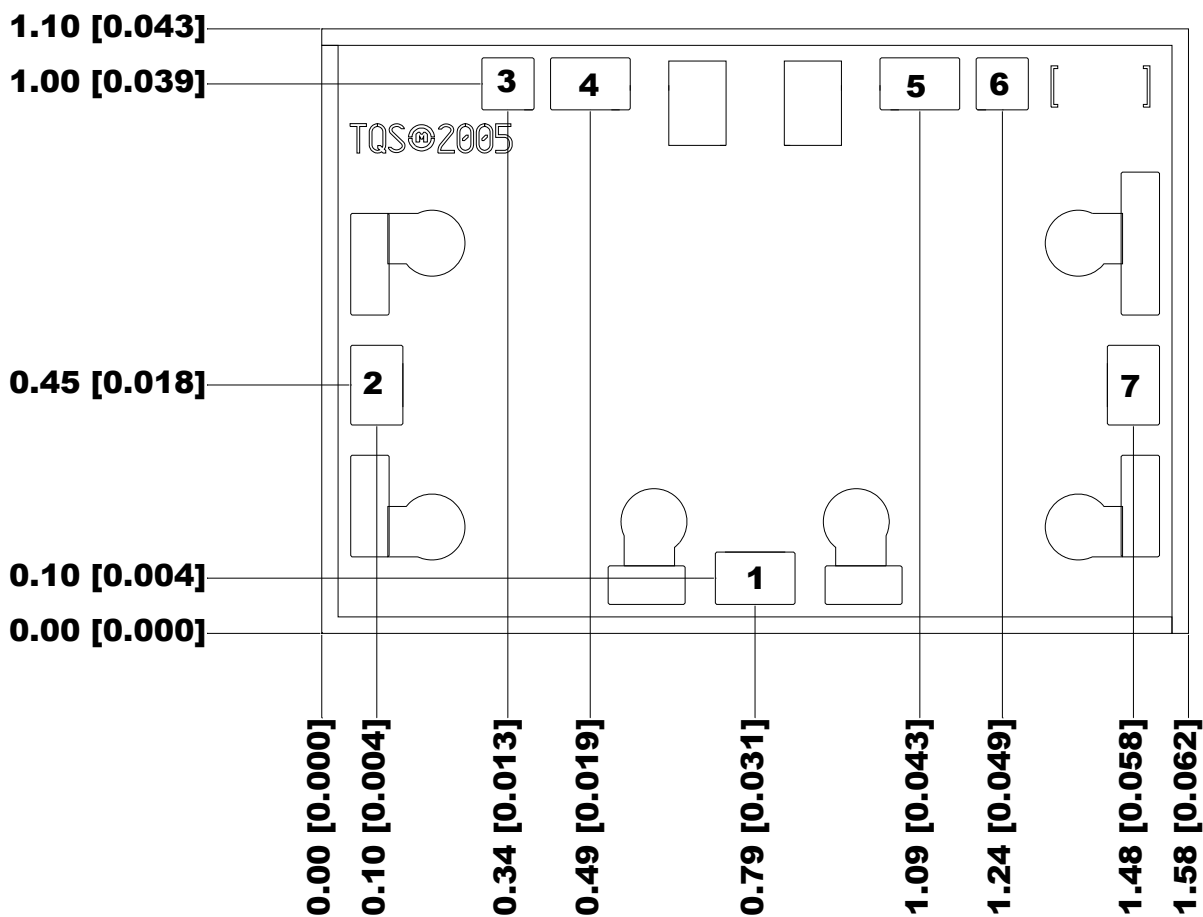

**Units: millimeters (inches)**

**Thickness: 0.100 (0.004)**

**Chip edge to bond pad dimensions are shown to center of bond pad**

**Chip size tolerance: +/- 0.051 (0.002)**

**GND IS BACKSIDE OF MMIC**

<b>Bond Pad #1</b>	<b>(RF In)</b>	<b>0.15 x 0.10 (0.006 x 0.004)</b>
<b>Bond Pad #2</b>	<b>(RF Out A)</b>	<b>0.10 x 0.15 (0.004 x 0.006)</b>
<b>Bond Pad #3</b>	<b>(VA)</b>	<b>0.10 x 0.10 (0.004 x 0.004)</b>
<b>Bond Pad #4</b>	<b>(IA)</b>	<b>0.15 x 0.10 (0.006 x 0.004)</b>
<b>Bond Pad #5</b>	<b>(IB)</b>	<b>0.15 x 0.10 (0.006 x 0.004)</b>
<b>Bond Pad #6</b>	<b>(VB)</b>	<b>0.10 x 0.10 (0.004 x 0.004)</b>
<b>Bond Pad #7</b>	<b>(RF Out B)</b>	<b>0.10 x 0.15 (0.004 x 0.006)</b>

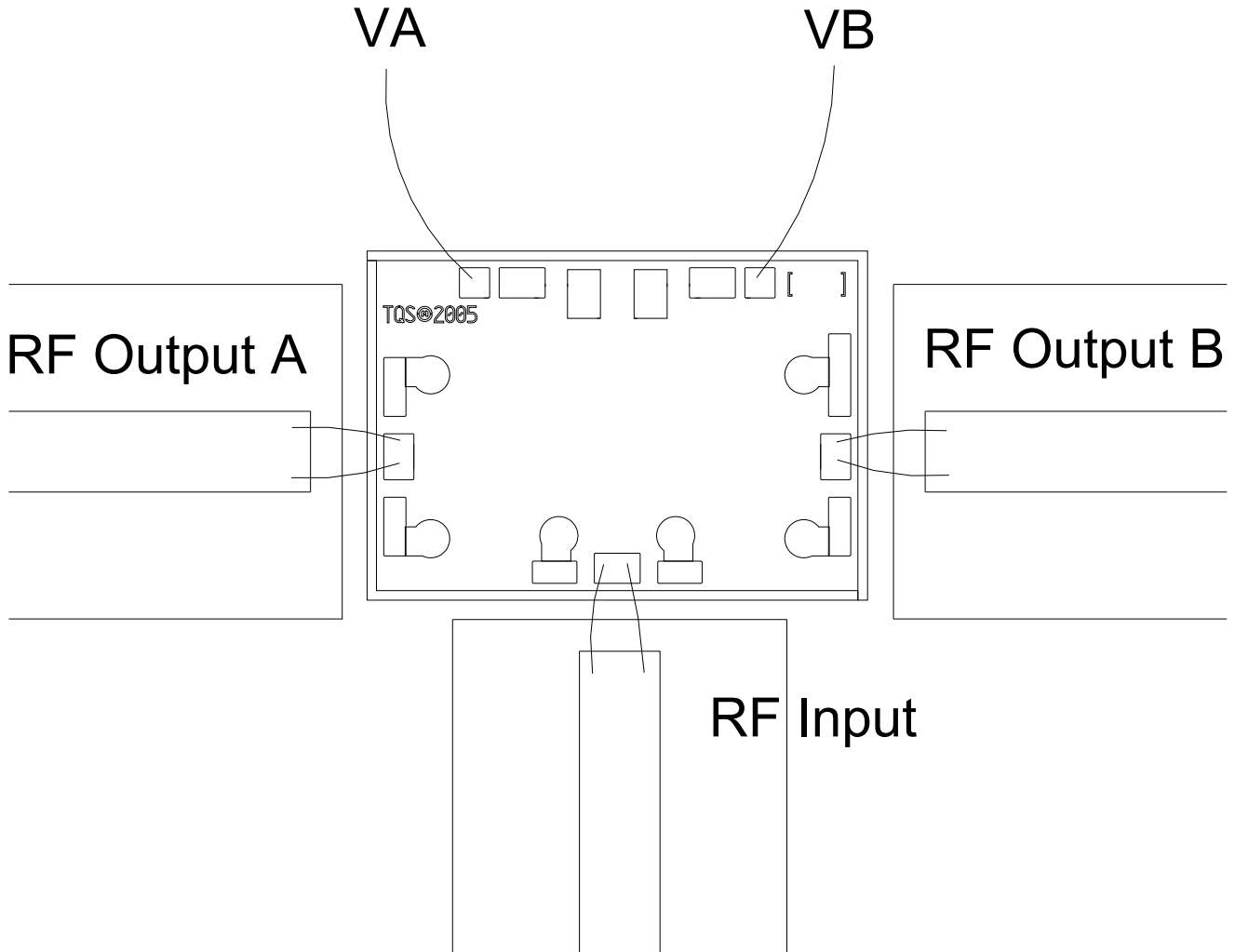

*GaAs MMIC devices are susceptible to damage from Electrostatic Discharge. Proper precautions should be observed during handling, assembly and test.*



**Alternate Chip Assembly & Bonding Diagram TGS4304**

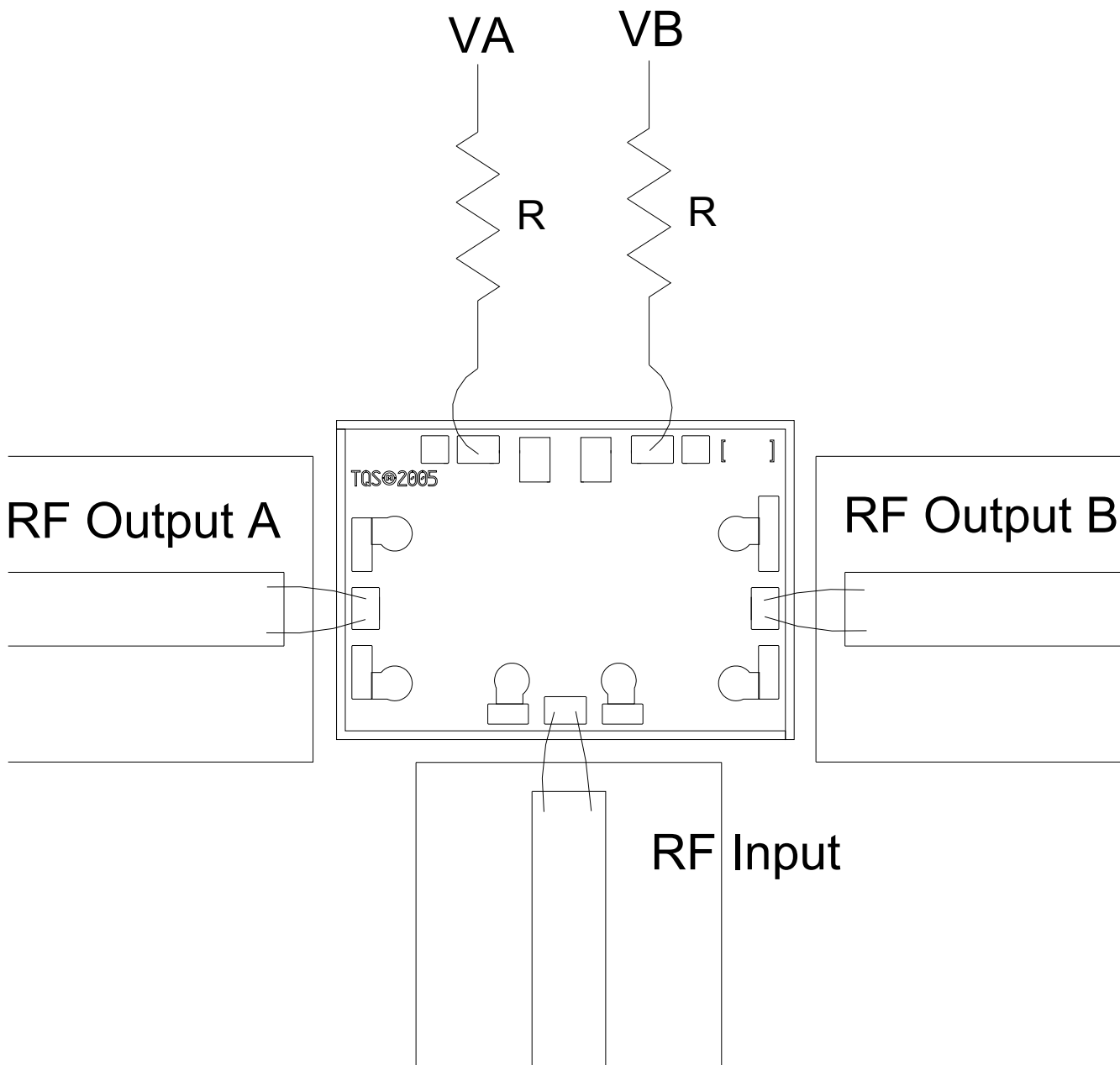

**TABLE IV  
BIAS RESISTOR VALUES**

Maximum Negative Bias Voltage	R
-5V	33 Ohms
-7.5V	117 Ohms
-10V	200 Ohms
-15V	367 Ohms
-20V	533 Ohms

## Assembly Process Notes

Reflow process assembly notes:

- Use AuSn (80/20) solder with limited exposure to temperatures at or above 300°C. (30 seconds maximum)
- An alloy station or conveyor furnace with reducing atmosphere should be used.
- No fluxes should be utilized.
- Coefficient of thermal expansion matching is critical for long-term reliability.
- Devices must be stored in a dry nitrogen atmosphere.

Component placement and adhesive attachment assembly notes:

- Vacuum pencils and/or vacuum collets are the preferred method of pick up.
- Air bridges must be avoided during placement.
- The force impact is critical during auto placement.
- Organic attachment can be used in low-power applications.
- Curing should be done in a convection oven; proper exhaust is a safety concern.
- Microwave or radiant curing should not be used because of differential heating.
- Coefficient of thermal expansion matching is critical.

Interconnect process assembly notes:

- Thermosonic ball bonding is the preferred interconnect technique.
- Force, time, and ultrasonics are critical parameters.
- Aluminum wire should not be used.
- Maximum stage temperature is 200°C.

***GaAs MMIC devices are susceptible to damage from Electrostatic Discharge. Proper precautions should be observed during handling, assembly and test.***