

FEATURES

- Single-chip synthesized tuner for dual-band mobile TV applications
- Zero-IF single-conversion architecture eliminates need for SAW filters
- Covers entire UHF Band IV/Band V (470 MHz to 862 MHz)
- Typical AGC dynamic range: -102 dBm to 0 dBm
- Low power consumption: 200 mW (UHF)
- On-chip features include
 - Fast switching fractional-N PLL
 - Low phase noise and wide frequency range VCO
 - Bandwidth-adjustable low-pass filter
- Integrated baseband VGA for direct connection to digital demodulators
- Noise/linearity optimization through internal RF AGC loop
- Adjustable take-over point
- I²C serial bus interface
- Small 5 mm × 5 mm, 32-lead lead frame chip scale package (LFCSP)
- Minimal external components

APPLICATIONS

- DVB-H/DVB-T/DTMB/CMMB mobile and portable TV receivers
- UHF mobile and portable TV receivers

GENERAL DESCRIPTION

The ADMTV102 is a highly integrated CMOS, single-chip, zero-IF conversion tuner IC for mobile TV standards, such as DVB-H, DVB-T, DTMB, and CMMB. The part includes an RF input band, UHF. The building blocks of the ADMTV102 include LNAs, RF PGAs, I/Q downconversion mixers, bandwidth-adjustable low-pass filters, baseband VGAs, a VCO, and a fractional-N PLL. The on-chip low phase noise VCO, along with the high resolution fractional-N frequency synthesizer, makes in-band phase noise low enough for mobile TV applications.

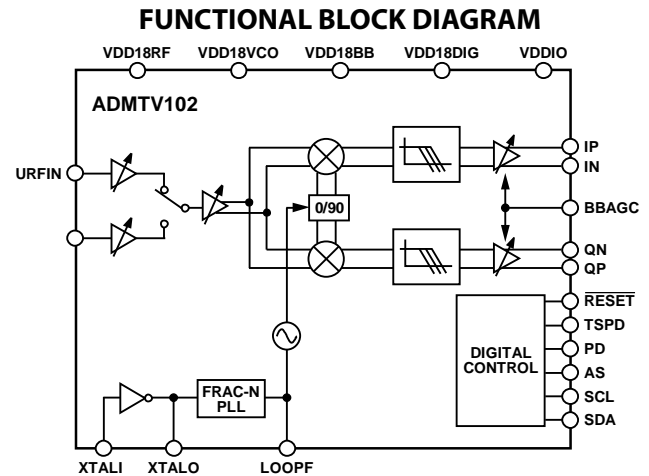

Figure 1.

The ADMTV102 supports dual-band mobile TV standards with low power consumption, such as 200 mW for DVB-H. Using a small, Pb-free, 5 mm × 5 mm 32-lead LFCSP, the ADMTV102 is an ideal solution for highly integrated dual-band mobile and portable applications where low power consumption is critical. The part has an I²C serial bus interface. Applications for the ADMTV102 include DVB-H, DVB-T, DTMB, and CMMB.

For more information on the ADMTV102, email Analog Devices, Inc., at Mobile_TV_support@analog.com.

Rev. Sp0

Information furnished by Analog Devices is believed to be accurate and reliable. However, no responsibility is assumed by Analog Devices for its use, nor for any infringements of patents or other rights of third parties that may result from its use. Specifications subject to change without notice. No license is granted by implication or otherwise under any patent or patent rights of Analog Devices. Trademarks and registered trademarks are the property of their respective owners.

NOTES

Purchase of licensed I²C components of Analog Devices or one of its sublicensed Associated Companies conveys a license for the purchaser under the Philips I²C Patent Rights to use these components in an I²C system, provided that the system conforms to the I²C Standard Specification as defined by Philips.