

## FEATURES

- Single Supply Operation
  - Input Voltage Range Extends to Ground
  - Output Swings to Ground While Sinking Current
- Pin Compatible to 1458 and 324 with Precision Specs
- *Guaranteed* Offset Voltage: 150 $\mu$ V Max
- *Guaranteed* Low Drift: 2 $\mu$ V/ $^{\circ}$ C Max
- *Guaranteed* Offset Current: 0.8nA Max
- *Guaranteed* High Gain
  - 5mA Load Current: 1.5 Million Min
  - 17mA Load Current: 0.8 Million Min
- *Guaranteed* Low Supply Current: 500 $\mu$ A Max
- Low Voltage Noise, 0.1Hz to 10Hz: 0.55 $\mu$ V<sub>P-P</sub>
- Low Current Noise—Better than OP-07, 0.07pA/ $\sqrt{\text{Hz}}$

## APPLICATIONS

- Battery-Powered Precision Instrumentation
  - Strain Gauge Signal Conditioners
  - Thermocouple Amplifiers
  - Instrumentation Amplifiers
- 4mA to 20mA Current Loop Transmitters
- Multiple Limit Threshold Detection
- Active Filters
- Multiple Gain Blocks

LT, LT, LTC, LTM, Linear Technology and the Linear logo are registered trademarks of Linear Technology Corporation. All other trademarks are the property of their respective owners.

## DESCRIPTION

The LT<sup>®</sup>1014 is the first precision quad operational amplifier which directly upgrades designs in the industry standard 14-pin DIP LM324/LM348/OP-11/4156 pin configuration. It is no longer necessary to compromise specifications, while saving board space and cost, as compared to single operational amplifiers.

The LT1014's low offset voltage of 50 $\mu$ V, drift of 0.3 $\mu$ V/ $^{\circ}$ C, offset current of 0.15nA, gain of 8 million, common mode rejection of 117dB and power supply rejection of 120dB qualify it as four truly precision operational amplifiers. Particularly important is the low offset voltage, since no offset null terminals are provided in the quad configuration. Although supply current is only 350 $\mu$ A per amplifier, a new output stage design sources and sinks in excess of 20mA of load current, while retaining high voltage gain.

Similarly, the LT1013 is the first precision dual op amp in the 8-pin industry standard configuration, upgrading the performance of such popular devices as the MC1458/MC1558, LM158 and OP-221. The LT1013's specifications are similar to (even somewhat better than) the LT1014's.

Both the LT1013 and LT1014 can be operated off a single 5V power supply: input common mode range includes ground; the output can also swing to within a few millivolts of ground. Crossover distortion, so apparent on previous single-supply designs, is eliminated. A full set of specifications is provided with  $\pm 15$ V and single 5V supplies.

## TYPICAL APPLICATION

### 3-Channel Thermocouple Thermometer

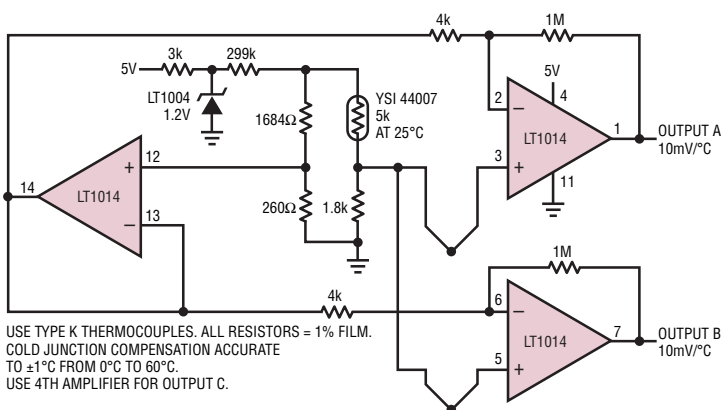

### LT1014 Distribution of Offset Voltage

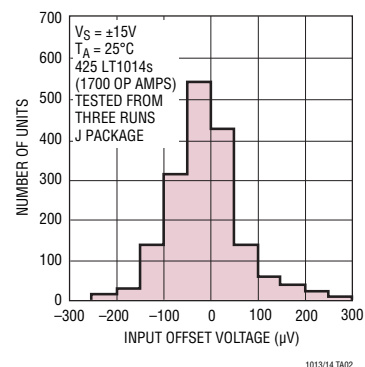

10134fd

# LT1013/LT1014

## ABSOLUTE MAXIMUM RATINGS (Note 1)

Supply Voltage .....  $\pm 22V$   
 Differential Input Voltage.....  $\pm 30V$   
 Input Voltage..... Equal to Positive Supply Voltage  
 ..... 5V Below Negative Supply Voltage  
 Output Short-Circuit Duration ..... Indefinite  
 Storage Temperature Range  
 All Grades .....  $-65^{\circ}C$  to  $150^{\circ}C$

Lead Temperature (Soldering, 10 sec.) .....  $300^{\circ}C$   
 Operating Temperature Range

LT1013AM/LT1013M/  
 LT1014AM/LT1014M .....  $-55^{\circ}C$  to  $125^{\circ}C$   
 LT1013AC/LT1013C/LT1013D  
 LT1014AC/LT1014C/LT1014D .....  $0^{\circ}C$  to  $70^{\circ}C$   
 LT1013I/ LT1014I .....  $-40^{\circ}C$  to  $85^{\circ}C$

## PIN CONFIGURATION

<p>LT1013</p> <p>TOP VIEW</p> <p>+INA 1 8 -INA          V<sup>-</sup> 2 7 OUTA          +INB 3 6 V<sup>+</sup>          -INB 4 5 OUTB</p> <p>S8 PACKAGE          8-LEAD PLASTIC SO</p> <p>NOTE: THIS PIN CONFIGURATION DIFFERS FROM THE STANDARD 8-PIN DUAL-IN-LINE CONFIGURATION</p> <p><math>T_{JMAX} = 150^{\circ}C, \theta_{JA} = 190^{\circ}C/W</math></p>	<p>LT1013</p> <p>TOP VIEW</p> <p>OUTPUT A 1 8 V<sup>+</sup>          -IN A 2 7 OUTPUT B          +IN A 3 6 -IN B          V<sup>-</sup> 4 5 +IN B</p> <p>N8 PACKAGE          8-LEAD PDIP  <math>T_{JMAX} = 150^{\circ}C, \theta_{JA} = 130^{\circ}C</math></p> <p>J8 PACKAGE          8-LEAD CERDIP  <math>T_{JMAX} = 150^{\circ}C, \theta_{JA} = 100^{\circ}C</math></p> <p><b>OBSOLETE PACKAGE</b></p> <p>Consider the N or S8 Packages for Alternate Source</p>	<p>LT1013</p> <p>TOP VIEW</p> <p>V<sup>+</sup>          8          OUTPUT A 1 7 OUTPUT B          -IN A 2 6 -IN B          +IN A 3 5 +IN B          V<sup>-</sup> (CASE)          4</p> <p>H PACKAGE          8-LEAD TO-5 METAL CAN</p> <p><math>T_{JMAX} = 125^{\circ}C, \theta_{JA} = 55^{\circ}C/W</math></p> <p><b>OBSOLETE PACKAGE</b></p> <p>Consider the N or S8 (Not N8) Packages for Alternate Source</p>
<p>LT1014</p> <p>TOP VIEW</p> <p>OUTPUT A 1 16 OUTPUT D          -IN A 2 15 -IN D          +IN A 3 14 +IN D          V<sup>+</sup> 4 13 V<sup>-</sup>          +IN B 5 12 +IN C          -IN B 6 11 -IN C          OUTPUT B 7 10 OUTPUT C          NC 8 9 NC</p> <p>SW PACKAGE          16-LEAD PLASTIC SO</p> <p><math>T_{JMAX} = 150^{\circ}C, \theta_{JA} = 130^{\circ}C/W</math></p>	<p>LT1014</p> <p>TOP VIEW</p> <p>OUTPUT A 1 14 OUTPUT D          -IN A 2 13 -IN D          +IN A 3 12 +IN D          V<sup>+</sup> 4 11 V<sup>-</sup>          +IN B 5 10 +IN C          -IN B 6 9 -IN C          OUTPUT B 7 8 OUTPUT C</p> <p>N PACKAGE          14-LEAD PDIP  <math>T_{JMAX} = 150^{\circ}C, \theta_{JA} = 100^{\circ}C</math></p> <p>J PACKAGE          14-LEAD CERDIP  <math>T_{JMAX} = 150^{\circ}C, \theta_{JA} = 100^{\circ}C</math></p> <p><b>OBSOLETE PACKAGE</b></p> <p>Consider the N or SW Packages for Alternate Source</p>	

**ORDER INFORMATION**

LEAD FREE FINISH	TAPE AND REEL	PART MARKING	PACKAGE DESCRIPTION	TEMPERATURE RANGE
LT1013DS8#PBF	LT1013DS8#TRPBF	1013	8-Lead Plastic SO	0°C to 70°C
LT1013IS8#PBF	LT1013IS8#TRPBF	1013I	8-Lead Plastic SO	-40°C to 85°C
LT1013ACN8#PBF	LT1013ACN8#TRPBF	LT1013ACN8	8-Lead PDIP	0°C to 70°C
LT1013CN8#PBF	LT1013CN8#TRPBF	LT1013CN8	8-Lead PDIP	0°C to 70°C
LT1013DN8#PBF	LT1013DN8#TRPBF	LT1013DN8	8-Lead PDIP	0°C to 70°C
LT1013IN8#PBF	LT1013IN8#TRPBF	LT1013IN8	8-Lead PDIP	-40°C to 85°C
LT1014DSW#PBF	LT1014DSW#TRPBF	LT1014DSW	16-Lead Plastic SO	0°C to 70°C
LT1014ISW#PBF	LT1014ISW#TRPBF	LT1014ISW	16-Lead Plastic SO	-40°C to 85°C
LT1014ACN#PBF	LT1014ACN#TRPBF	LT1014ACN	14-Lead PDIP	0°C to 70°C
LT1014CN#PBF	LT1014CN#TRPBF	LT1014CN	14-Lead PDIP	0°C to 70°C
LT1014DN#PBF	LT1014DN#TRPBF	LT1014DN	14-Lead PDIP	0°C to 70°C
LT1014IN#PBF	LT1014IN#TRPBF	LT1014IN	14-Lead PDIP	-40°C to 85°C
LT1013AMJ8#PBF	LT1013AMJ8#TRPBF	LT1013AMJ8	8-Lead CERDIP	-55°C to 125°C <b>(OBSOLETE)</b>
LT1013MJ8#PBF	LT1013MJ8#TRPBF	LT1013MJ8	8-Lead CERDIP	-55°C to 125°C <b>(OBSOLETE)</b>
LT1013ACJ8#PBF	LT1013ACJ8#TRPBF	LT1013ACJ8	8-Lead CERDIP	0°C to 70°C <b>(OBSOLETE)</b>
LT1013CJ8#PBF	LT1013CJ8#TRPBF	LT1013CJ8	8-Lead CERDIP	0°C to 70°C <b>(OBSOLETE)</b>
LT1013AMH#PBF	LT1013AMH#TRPBF	LT1013AMH	8-Lead TO-5 Metal Can	-55°C to 125°C <b>(OBSOLETE)</b>
LT1013MH#PBF	LT1013MH#TRPBF	LT1013MH	8-Lead TO-5 Metal Can	-55°C to 125°C <b>(OBSOLETE)</b>
LT1013ACH#PBF	LT1013ACH#TRPBF	LT1013ACH	8-Lead TO-5 Metal Can	0°C to 70°C <b>(OBSOLETE)</b>
LT1013CH#PBF	LT1013CH#TRPBF	LT1013CH	8-Lead TO-5 Metal Can	0°C to 70°C <b>(OBSOLETE)</b>
LT1014AMJ#PBF	LT1014AMJ#TRPBF	LT1014AMJ	14-Lead CERDIP	-55°C to 125°C <b>(OBSOLETE)</b>
LT1014MJ#PBF	LT1014MJ#TRPBF	LT1014MJ	14-Lead CERDIP	-55°C to 125°C <b>(OBSOLETE)</b>
LT1014ACJ#PBF	LT1014ACJ#TRPBF	LT1014ACJ	14-Lead CERDIP	0°C to 70°C <b>(OBSOLETE)</b>
LT1014CJ#PBF	LT1014CJ#TRPBF	LT1014CJ	14-Lead CERDIP	0°C to 70°C <b>(OBSOLETE)</b>

Consult LTC Marketing for parts specified with wider operating temperature ranges.

Consult LTC Marketing for information on non-standard lead based finish parts.

For more information on lead free part marking, go to: <http://www.linear.com/leadfree/>

For more information on tape and reel specifications, go to: <http://www.linear.com/tapeandreeel/>

# LT1013/LT1014

## ELECTRICAL CHARACTERISTICS $T_A = 25^\circ\text{C}$ . $V_S = \pm 15\text{V}$ , $V_{CM} = 0\text{V}$ unless otherwise noted.

SYMBOL	PARAMETER	CONDITIONS	LT1013AM/AC LT1014AM/AC			LT1013C/D/I/M LT1014C/D/I/M			UNITS
			MIN	TYP	MAX	MIN	TYP	MAX	
$V_{OS}$	Input Offset Voltage	LT1013		40	150		60	300	$\mu\text{V}$
		LT1014		50	180		60	300	$\mu\text{V}$
		LT1013D/I, LT1014D/I					200	800	$\mu\text{V}$
	Long-Term Input Offset Voltage Stability			0.4		0.5		$\mu\text{V}/\text{Mo.}$	
$I_{SO}$	Input Offset Current			0.15	0.8		0.2	1.5	nA
$I_B$	Input Bias Current			12	20		15	30	nA
$e_n$	Input Noise Voltage	0.1Hz to 10Hz		0.55			0.55		$\mu\text{V}_{\text{P-P}}$
$e_n$	Input Noise Voltage Density	$f_0 = 10\text{Hz}$		24			24		$\text{nV}/\sqrt{\text{Hz}}$
		$f_0 = 1000\text{Hz}$		22			22		$\text{nV}/\sqrt{\text{Hz}}$
$i_n$	Input Noise Current Density	$f_0 = 10\text{Hz}$		0.07			0.07		$\text{pA}/\sqrt{\text{Hz}}$
	Input Resistance – Differential Common Mode	(Note 2)	100	400		70	300		$\text{M}\Omega$
				5			4		$\text{G}\Omega$
$A_{VOL}$	Large-Signal Voltage Gain	$V_O = \pm 10\text{V}$ , $R_L = 2\text{k}$	1.5	8.0		1.2	7.0		$\text{V}/\mu\text{V}$
		$V_O = \pm 10\text{V}$ , $R_L = 600\Omega$	0.8	2.5		0.5	2.0		$\text{V}/\mu\text{V}$
	Input Voltage Range		13.5	13.8		13.5	13.8		V
			-15.0	-15.3		-15.0	-15.3		V
CMRR	Common Mode Rejection Ratio	$V_{CM} = 13.5\text{V}$ , $-15.0\text{V}$	100	117		97	114		dB
PSRR	Power Supply Rejection Ratio	$V_S = \pm 2\text{V}$ to $\pm 18\text{V}$	103	120		100	117		dB
				123	140		120	137	
$V_{OUT}$	Output Voltage Swing	$R_L = 2\text{k}$	$\pm 13$	$\pm 14$		$\pm 12.5$	$\pm 14$		V
				0.2	0.4		0.2	0.4	
$I_S$	Supply Current	Per Amplifier		0.35	0.50		0.35	0.55	mA

$T_A = 25^\circ\text{C}$ .  $V_S^+ = 5\text{V}$ ,  $V_S^- = 0\text{V}$ ,  $V_{OUT} = 1.4\text{V}$ ,  $V_{CM} = 0\text{V}$  unless otherwise noted

SYMBOL	PARAMETER	CONDITIONS	LT1013AM/AC LT1014AM/AC			LT1013C/D/I/M LT1014C/D/I/M			UNITS	
			MIN	TYP	MAX	MIN	TYP	MAX		
$V_{OS}$	Input Offset Voltage	LT1013		60	250		90	450	$\mu\text{V}$	
		LT1014		70	280		90	450	$\mu\text{V}$	
		LT1013D/I, LT1014D/I					250	950	$\mu\text{V}$	
$I_{OS}$	Input Offset Current			0.2	1.3		0.3	2.0	nA	
$I_B$	Input Bias Current			15	35		18	50	nA	
$A_{VOL}$	Large-Signal Voltage Gain	$V_O = 5\text{mV}$ to $4\text{V}$ , $R_L = 500\Omega$		1.0			1.0		$\text{V}/\mu\text{V}$	
				3.5	3.8		3.5	3.8		V
	Input Voltage Range			-0.3		0	-0.3		V	
$V_{OUT}$	Output Voltage Swing	Output Low, No Load Output Low, $600\Omega$ to Ground Output Low, $I_{SINK} = 1\text{mA}$ Output High, No Load Output High, $600\Omega$ to Ground		15	25		15	25	mV	
					5	10		5	10	mV
				220	350		220	350	mV	
			4.0	4.4		4.0	4.4		V	
			3.4	4.0		3.4	4.0		V	
$I_S$	Supply Current	Per Amplifier		0.31	0.45		0.32	0.50	mA	

10134fd

**ELECTRICAL CHARACTERISTICS** The ● denotes the specifications which apply over the temperature range  $-55^{\circ}\text{C} \leq T_A \leq 125^{\circ}\text{C}$ .  $V_S = \pm 15\text{V}$ ,  $V_{CM} = 0\text{V}$  unless otherwise noted.

SYMBOL	PARAMETER	CONDITIONS	LT1013AM			LT1014AM			LT1013M/LT1014M			UNITS	
			MIN	TYP	MAX	MIN	TYP	MAX	MIN	TYP	MAX		
$V_{OS}$	Input Offset Voltage	$V_S = 5\text{V}, 0\text{V}; V_O = 1.4\text{V}$ $-55^{\circ}\text{C} \leq T_A \leq 100^{\circ}\text{C}$ $V_{CM} = 0.1\text{V}, T_A = 125^{\circ}\text{C}$ $V_{CM} = 0\text{V}, T_A = 125^{\circ}\text{C}$	●	80	300		90	350		110	550	$\mu\text{V}$	
			●	80	450		90	480		100	750	$\mu\text{V}$	
				120	450		150	480		200	750	$\mu\text{V}$	
				250	900		300	960		400	1500	$\mu\text{V}$	
	Input Offset Voltage Drift	(Note 3)	●	0.4	2.0		0.4	2.0		0.5	2.5	$\mu\text{V}/^{\circ}\text{C}$	
$I_{OS}$	Input Offset Current	$V_S = 5\text{V}, 0\text{V}; V_O = 1.4\text{V}$	●	0.3	2.5		0.3	2.8		0.4	5.0	nA	
			●	0.6	6.0		0.7	7.0		0.9	10.0	nA	
$I_B$	Input Bias Current	$V_S = 5\text{V}, 0\text{V}; V_O = 1.4\text{V}$	●	15	30		15	30		18	45	nA	
			●	20	80		25	90		28	120	nA	
$A_{VOL}$	Large-Signal Voltage Gain	$V_O = \pm 10\text{V}, R_L = 2\text{k}$	●	0.5	2.0		0.4	2.0		0.25	2.0	$\text{V}/\mu\text{V}$	
CMRR	Common Mode Rejection	$V_{CM} = 13.0\text{V}, -14.9\text{V}$	●	97	114		96	114		94	113	dB	
PSRR	Power Supply Rejection Ratio	$V_S = \pm 2\text{V}$ to $\pm 18\text{V}$	●	100	117		100	117		97	116	dB	
$V_{OUT}$	Output Voltage Swing	$R_L = 2\text{k}$ $V_S = 5\text{V}, 0\text{V}$ $R_L = 600\Omega$ to Ground Output Low Output High	●	$\pm 12$	$\pm 13.8$		$\pm 12$	$\pm 13.8$		$\pm 11.5$	$\pm 13.8$	V	
			●		6	15		6	15		6	18	mV
			●	3.2	3.8		3.2	3.8		3.1	3.8		V
$I_S$	Supply Current Per Amplifier	$V_S = 5\text{V}, 0\text{V}; V_O = 1.4\text{V}$	●	0.38	0.60		0.38	0.60		0.38	0.7	mA	
			●		0.34	0.55		0.34	0.55		0.34	0.65	mA

# LT1013/LT1014

## ELECTRICAL CHARACTERISTICS

The ● denotes the specifications which apply over the temperature range  $-40^{\circ}\text{C} \leq T_A \leq 85^{\circ}\text{C}$  for LT1013I, LT1014I,  $0^{\circ}\text{C} \leq T_A \leq 70^{\circ}\text{C}$  for LT1013C, LT1013D, LT1014C, LT1014D.  $V_S = \pm 15\text{V}$ ,  $V_{CM} = 0\text{V}$  unless otherwise noted.

SYMBOL	PARAMETER	CONDITIONS	LT1013AC			LT1014AC			LT1013C/D/I LT1014C/D/I			UNITS
			MIN	TYP	MAX	MIN	TYP	MAX	MIN	TYP	MAX	
$V_{OS}$	Input Offset Voltage	LT1013D/I, LT1014D/I $V_S = 5\text{V}, 0\text{V}; V_O = 1.4\text{V}$ LT1013D/I, LT1014D/I $V_S = 5\text{V}, 0\text{V}; V_O = 1.4\text{V}$	●	55	240		65	270	80	400	$\mu\text{V}$	
			●						230	1000	$\mu\text{V}$	
			●	75	350		85	380	110	570	$\mu\text{V}$	
			●						280	1200	$\mu\text{V}$	
	Average Input Offset Voltage Drift	(Note 3) LT1013D/I, LT1014D/I	●	0.3	2.0		0.3	2.0	0.4	2.5	$\mu\text{V}/^{\circ}\text{C}$	
			●						0.7	5.0	$\mu\text{V}/^{\circ}\text{C}$	
$I_{OS}$	Input Offset Current	$V_S = 5\text{V}, 0\text{V}; V_O = 1.4\text{V}$	●	0.2	1.5		0.2	1.7	0.3	2.8	nA	
			●	0.4	3.5		0.4	4.0	0.5	6.0	nA	
$I_B$	Input Bias Current	$V_S = 5\text{V}, 0\text{V}; V_O = 1.4\text{V}$	●	13	25		13	25	16	38	nA	
			●	18	55		20	60	24	90	nA	
$A_{VOL}$	Large-Signal Voltage Gain	$V_O = \pm 10\text{V}, R_L = 2\text{k}$	●	1.0	5.0		1.0	5.0	0.7	4.0	$\text{V}/\mu\text{V}$	
CMRR	Common Mode Rejection Ratio	$V_{CM} = 13.0\text{V}, -15.0\text{V}$	●	98	116		98	116	94	113	dB	
PSRR	Power Supply Rejection Ratio	$V_S = \pm 2\text{V}$ to $\pm 18\text{V}$	●	101	119		101	119	97	116	dB	
$V_{OUT}$	Output Voltage Swing	$R_L = 2\text{k}$ $V_S = 5\text{V}, 0\text{V}; R_L = 600\Omega$ Output Low Output High	●	$\pm 12.5$	$\pm 13.9$		$\pm 12.5$	$\pm 13.9$	$\pm 12.0$	$\pm 13.9$	V	
			●		6	13		6	13	6	13	mV
			●	3.3	3.9		3.3	3.9	3.2	3.9		V
$I_S$	Supply Current per Amplifier	$V_S = 5\text{V}, 0\text{V}; V_O = 1.4\text{V}$	●	0.36	0.55		0.36	0.55	0.37	0.60	mA	
			●	0.32	0.50		0.32	0.50	0.34	0.55	mA	

**Note 1:** Stresses beyond those listed under Absolute Maximum Ratings may cause permanent damage to the device. Exposure to any Absolute Rating condition for extended periods may affect device reliability and lifetime.

**Note 2:** This parameter is guaranteed by design and is not tested. Typical parameters are defined as the 60% yield of parameter distributions of individual amplifiers; i.e., out of 100 LT1014s (or 100 LT1013s) typically 240 op amps (or 120) will be better than the indicated specification.

**Note 3:** This parameter is not 100% tested.

# TYPICAL PERFORMANCE CHARACTERISTICS

**Offset Voltage Drift with Temperature of Representative Units**

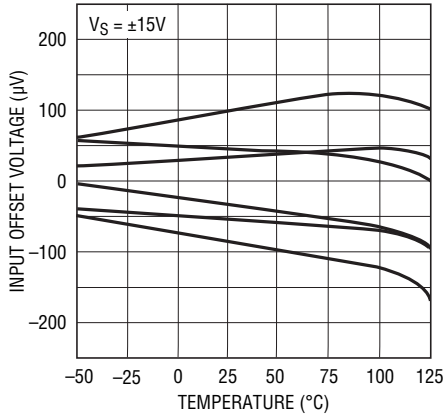

1013/14 TPC01

**Offset Voltage vs Balanced Source Resistance**

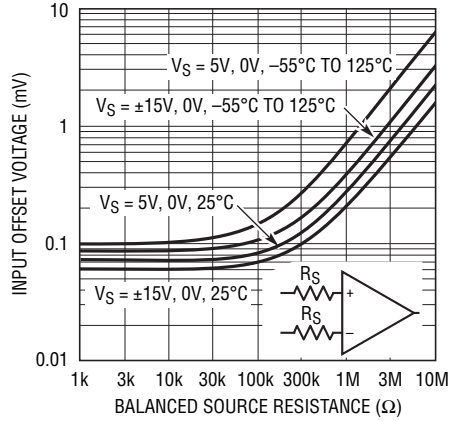

1013/14 TPC02

**Warm-Up Drift**

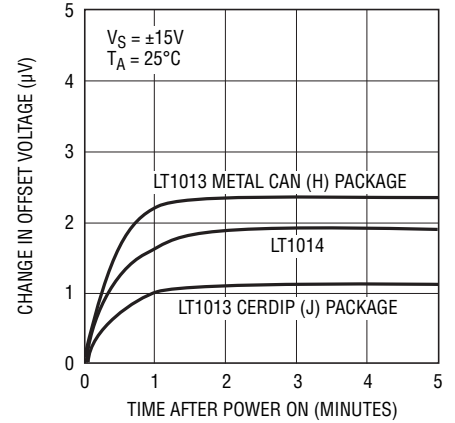

1013/14 TPC03

**Common Mode Rejection Ratio vs Frequency**

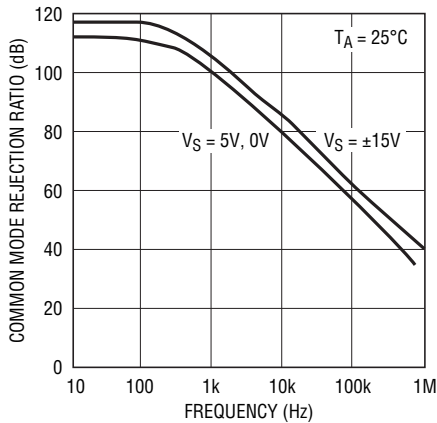

1013/14 TPC04

**Power Supply Rejection Ratio vs Frequency**

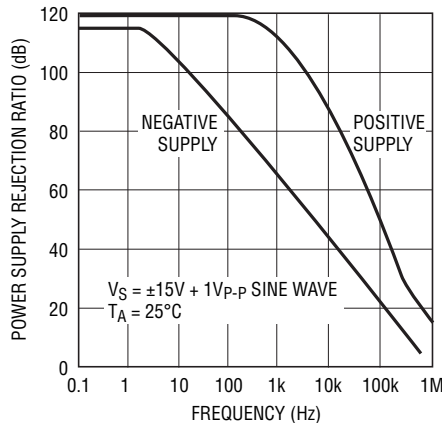

1013/14 TPC05

**0.1Hz to 10Hz Noise**

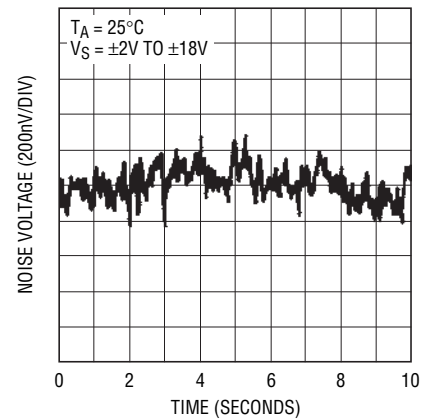

1013/14 TPC06

**Noise Spectrum**

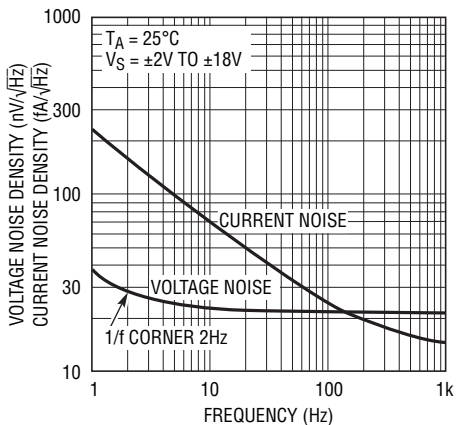

1013/14 TPC07

**10Hz Voltage Noise Distribution**

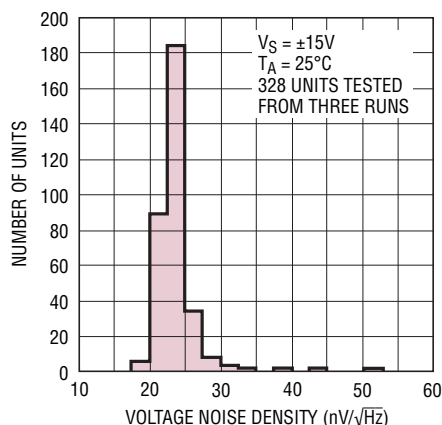

1013/14 TPC08

**Supply Current vs Temperature**

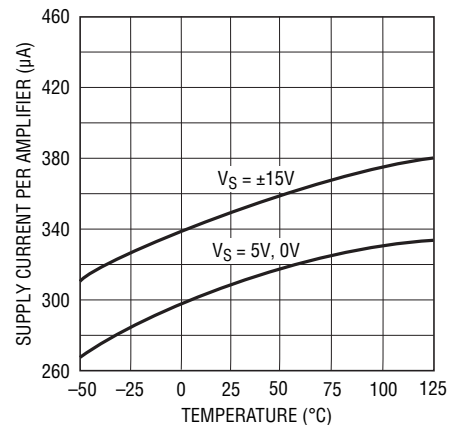

1013/14 TPC09

## TYPICAL PERFORMANCE CHARACTERISTICS

**Input Bias Current vs Common Mode Voltage**

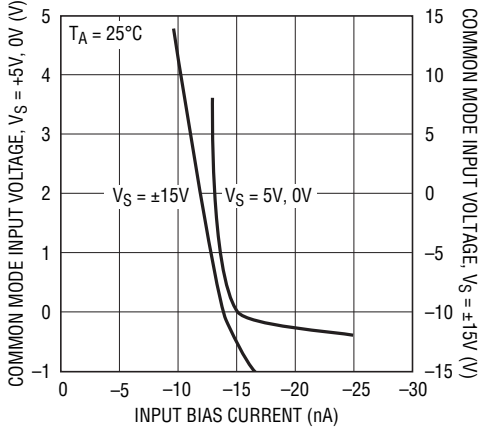

1013/14 TPC10

**Input Offset Current vs Temperature**

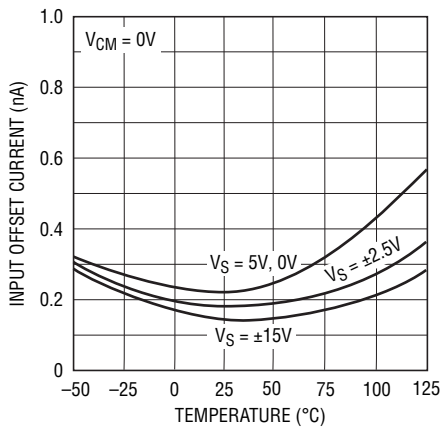

1013/14 TPC11

**Input Bias Current vs Temperature**

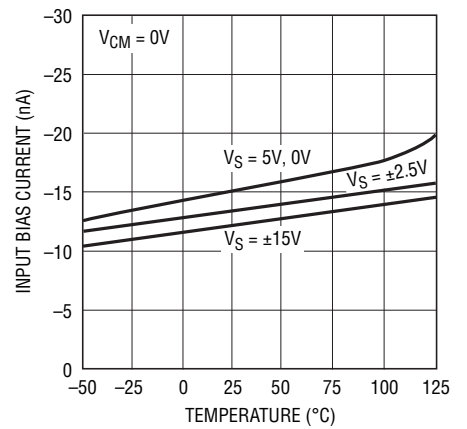

1013/14 TPC12

**Output Saturation vs Sink Current vs Temperature**

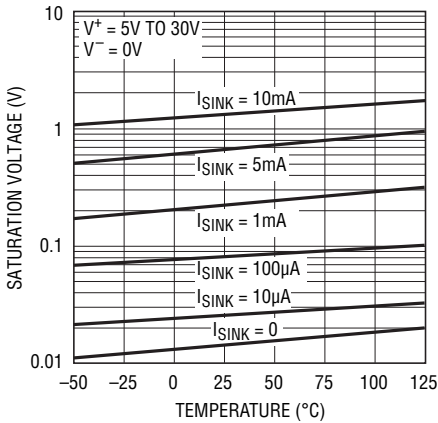

1013/14 TPC13

**Small-Signal Transient Response,  $V_S = \pm 15\text{V}$**

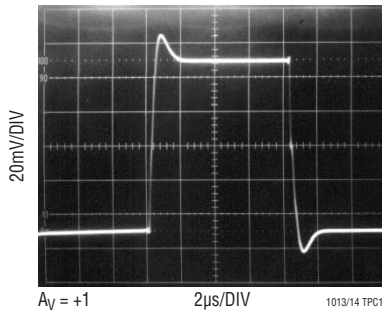

**Large-Signal Transient Response,  $V_S = \pm 15\text{V}$**

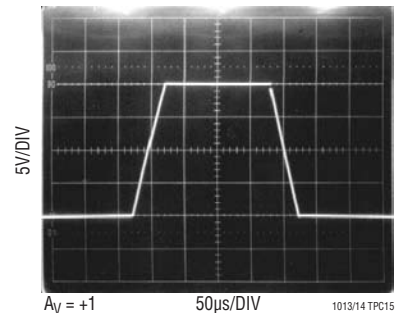

**Small-Signal Transient Response,  $V_S = 5\text{V}, 0\text{V}$**

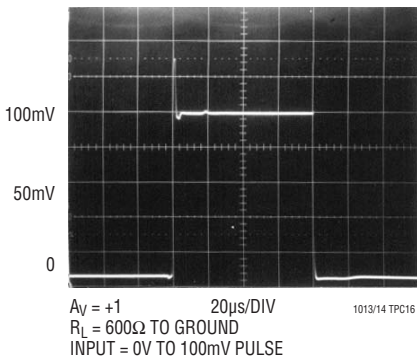

**Large-Signal Transient Response,  $V_S = 5\text{V}, 0\text{V}$**

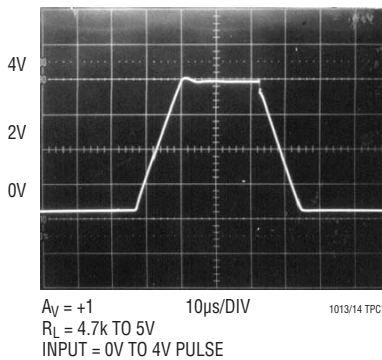

**Large-Signal Transient Response,  $V_S = 5\text{V}, 0\text{V}$**

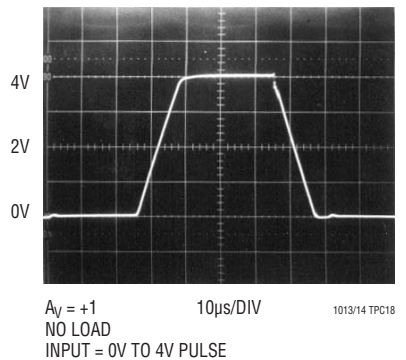



# TYPICAL PERFORMANCE CHARACTERISTICS

**Output Short-Circuit Current vs Time**

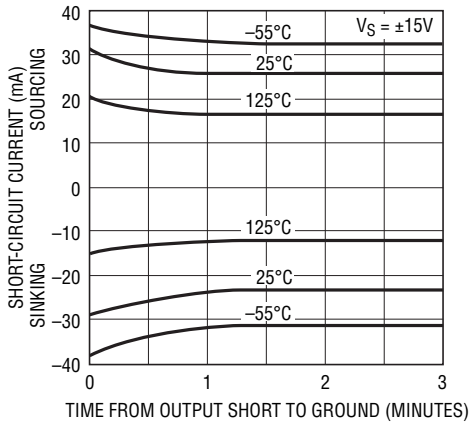

1013/14 TPC19

**Voltage Gain vs Load Resistance**

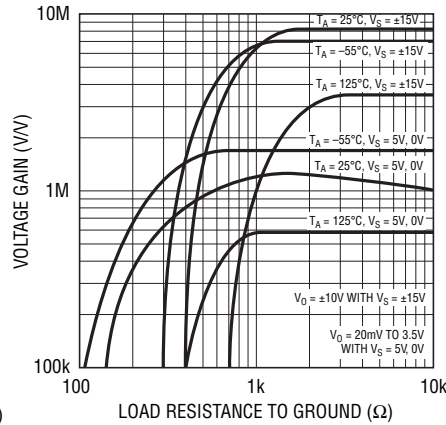

1013/14 TPC20

**Voltage Gain vs Frequency**

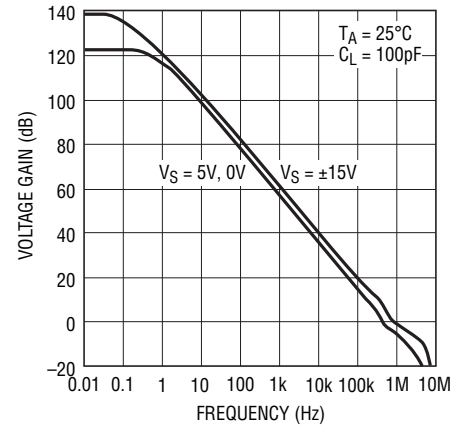

1013/14 TPC21

**Gain, Phase vs Frequency**

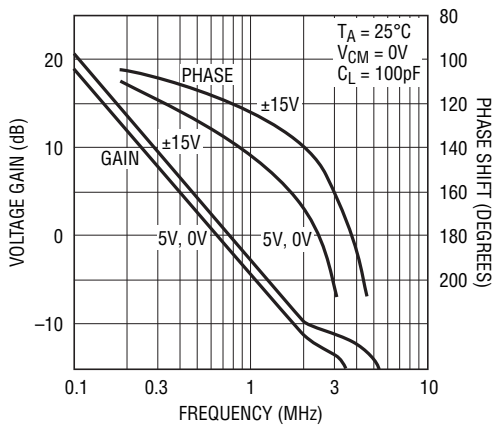

1013/14 TPC22

**Channel Separation vs Frequency**

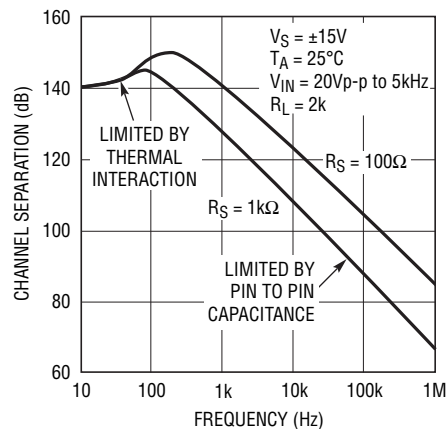

1013/14 TPC23

## APPLICATIONS INFORMATION

### Single Supply Operation

The LT1013/LT1014 are fully specified for single supply operation, i.e., when the negative supply is 0V. Input common mode range includes ground; the output swings within a few millivolts of ground. Single supply operation, however, can create special difficulties, both at the input and at the output. The LT1013/LT1014 have specific circuitry which addresses these problems.

At the input, the driving signal can fall below 0V—advertently or on a transient basis. If the input is more than a few hundred millivolts below ground, two distinct

problems can occur on previous single supply designs, such as the LM124, LM158, OP-20, OP-21, OP-220, OP-221, OP-420:

a) When the input is more than a diode drop below ground, unlimited current will flow from the substrate ( $V^-$  terminal) to the input. This can destroy the unit. On the LT1013/LT1014, the 400 $\Omega$  resistors, in series with the input (see Schematic Diagram), protect the devices even when the input is 5V below ground.

## APPLICATIONS INFORMATION

b) When the input is more than 400mV below ground (at 25°C), the input stage saturates (transistors Q3 and Q4) and phase reversal occurs at the output. This can cause lock-up in servo systems. Due to a unique phase reversal protection circuitry (Q21, Q22, Q27, Q28), the LT1013/LT1014's outputs do not reverse, as illustrated below, even when the inputs are at -1.5V.

There is one circumstance, however, under which the phase reversal protection circuitry does not function: when the other op amp on the LT1013, or one specific amplifier of the other three on the LT1014, is driven hard into negative saturation at the output.

Phase reversal protection does not work on amplifier:

A when D's output is in negative saturation. B's and C's outputs have no effect.

B when C's output is in negative saturation. A's and D's outputs have no effect.

C when B's output is in negative saturation. A's and D's outputs have no effect.

D when A's output is negative saturation. B's and C's outputs have no effect.

At the output, the aforementioned single supply designs either cannot swing to within 600mV of ground (OP-20) or cannot sink more than a few microamperes while swinging to ground (LM124, LM158). The LT1013/LT1014's all-NPN output stage maintains its low output resistance and high gain characteristics until the output is saturated.

In dual supply operations, the output stage is crossover distortion-free.

### Comparator Applications

The single supply operation of the LT1013/LT1014 lends itself to its use as a precision comparator with TTL compatible output:

In systems using both op amps and comparators, the LT1013/LT1014 can perform multiple duties; for example, on the LT1014, two of the devices can be used as op amps and the other two as comparators.

### Voltage Follower with Input Exceeding the Negative Common Mode Range

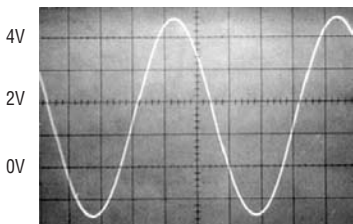

6V<sub>p-p</sub> INPUT, -1.5V TO 4.5V

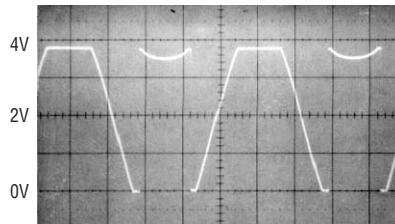

LM324, LM358, OP-20  
EXHIBIT OUTPUT PHASE  
REVERSAL

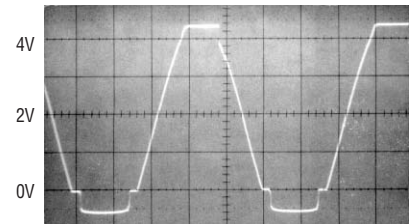

LT1013/LT1014  
NO PHASE REVERSAL

### Comparator Rise Response Time 10mV, 5mV, 2mV Overdrives

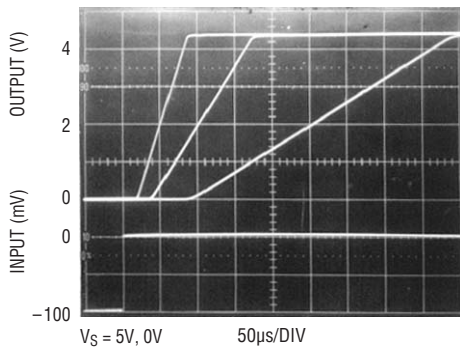

### Comparator Fall Response Time to 10mV, 5mV, 2mV Overdrives

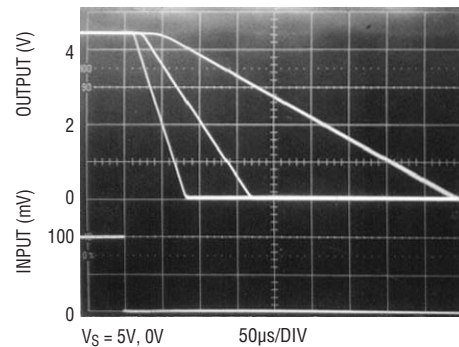

## APPLICATIONS INFORMATION

### Low Supply Operation

The minimum supply voltage for proper operation of the LT1013/LT1014 is 3.4V (three Ni-Cad batteries). Typical supply current at this voltage is 290µA, therefore power dissipation is only one milliwatt per amplifier.

### Noise Testing

For applications information on noise testing and calculations, please see the LT1007 or LT1008 data sheet.

### Test Circuit for Offset Voltage and Offset Drift with Temperature

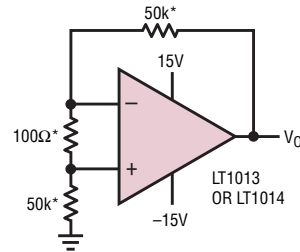

\* RESISTOR MUST HAVE LOW THERMOELECTRIC POTENTIAL.  
 \*\* THIS CIRCUIT IS ALSO USED AS THE BURN-IN CONFIGURATION, WITH SUPPLY VOLTAGES INCREASED TO ±20V.  
 $V_0 = 1000V_{OS}$

LT1013/14 F06

## TYPICAL APPLICATIONS

### 50MHz Thermal RMS-to-DC Converter

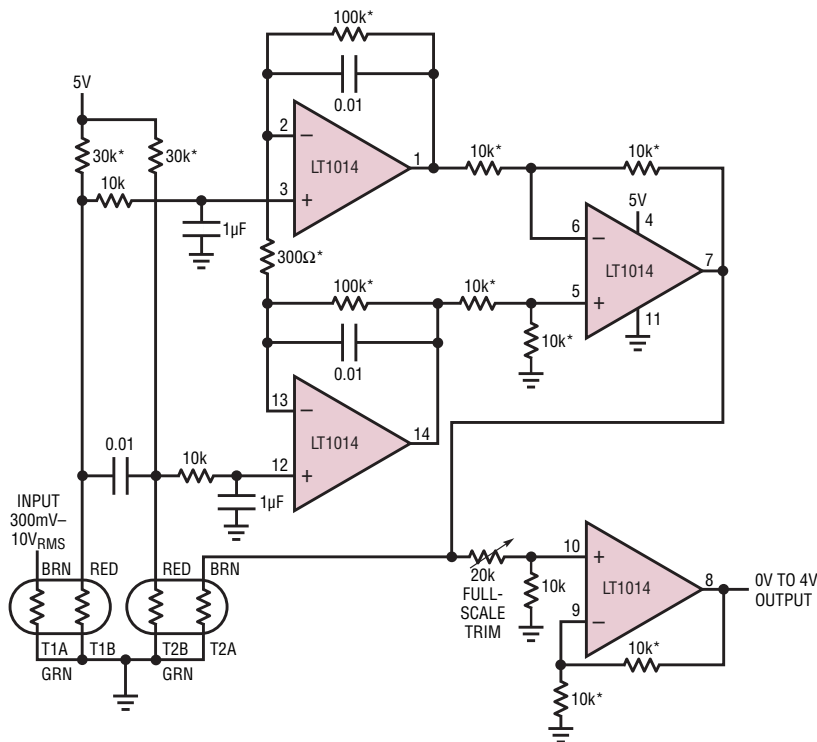

2% ACCURACY, DC-50MHz.  
 100:1 CREST FACTOR CAPABILITY.  
 \* 0.1% RESISTOR.  
 T1-T2 = YELLOW SPRINGS INST. CO. THERMISTOR COMPOSITE #44018.  
 ENCLOSE T1 AND T2 IN STYROFOAM.  
 7.5mW DISSIPATION.

1013/14 TA03

### 5V Single Supply Dual Instrumentation Amplifier

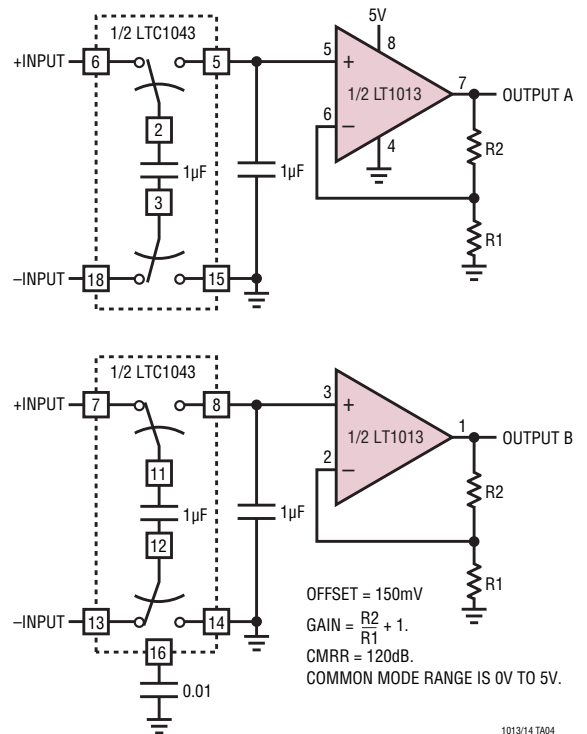

OFFSET = 150mV  
 GAIN =  $\frac{R_2}{R_1} + 1$ .  
 CMRR = 120dB.  
 COMMON MODE RANGE IS 0V TO 5V.

1013/14 TA04

## TYPICAL APPLICATIONS

### Hot-Wire Anemometer

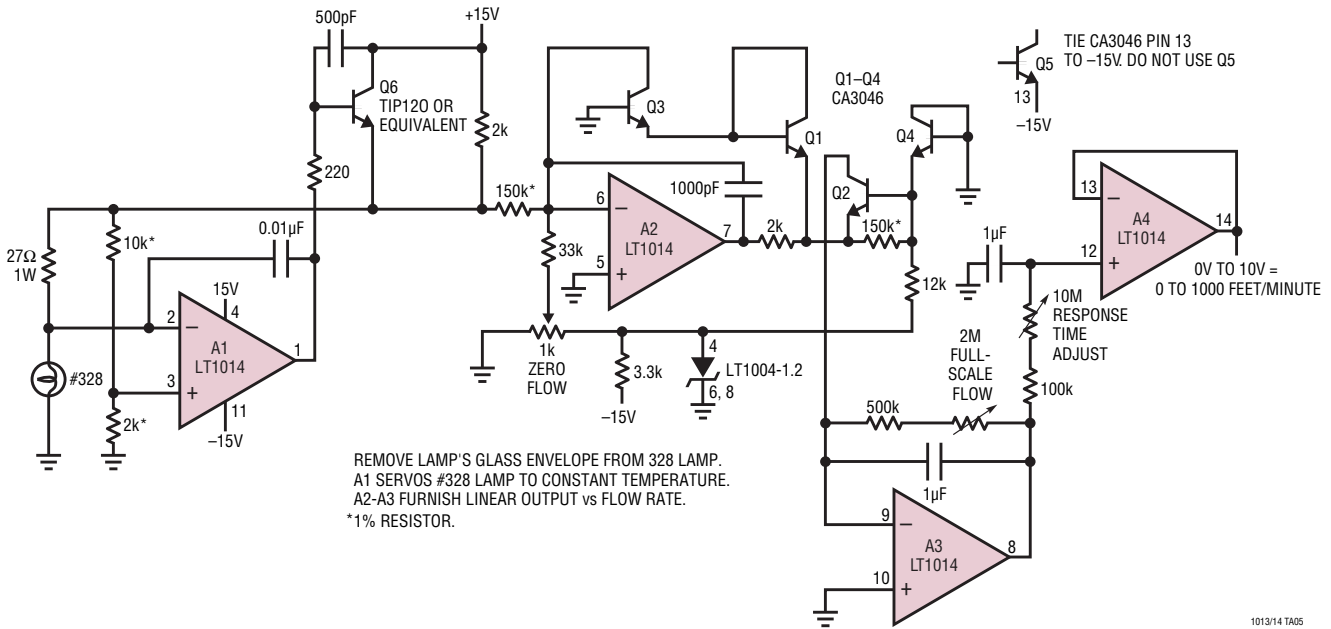

### Liquid Flowmeter

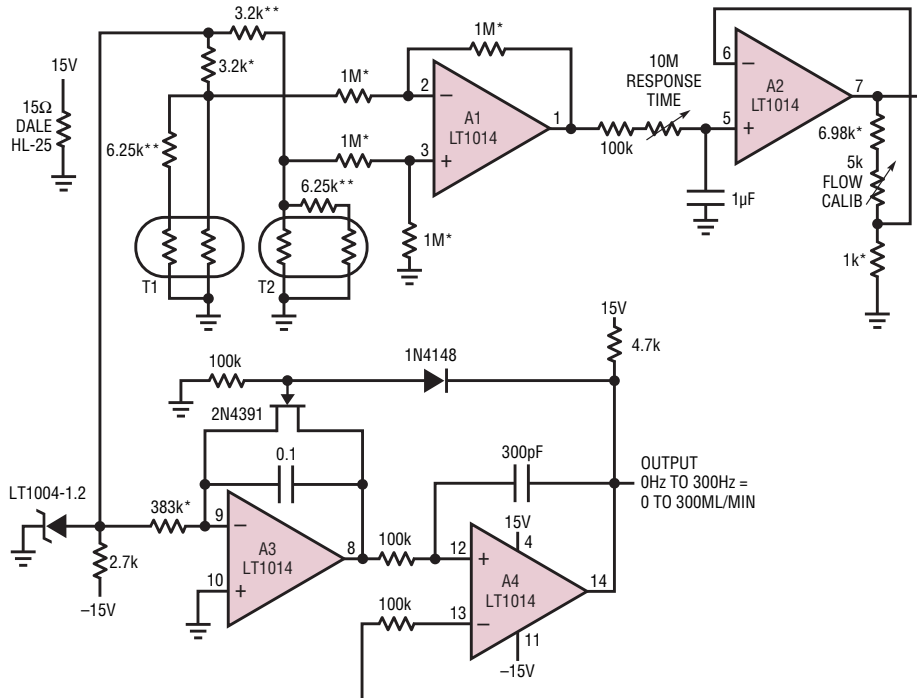

\* 1% FILM RESISTOR.  
 \*\* SUPPLIED WITH YSI THERMISTOR NETWORK.  
 T1, T2 YSI THERMISTOR NETWORK = #44201.  
 FLOW IN PIPE IS INVERSELY PROPORTIONAL TO RESISTANCE OF T1-T2 TEMPERATURE DIFFERENCE.  
 A1-A2 PROVIDE GAIN. A3-A4 PROVIDE LINEARIZED FREQUENCY OUTPUT.

1013/14 TA06

10134fd

TYPICAL APPLICATIONS

5V Powered Precision Instrumentation Amplifier

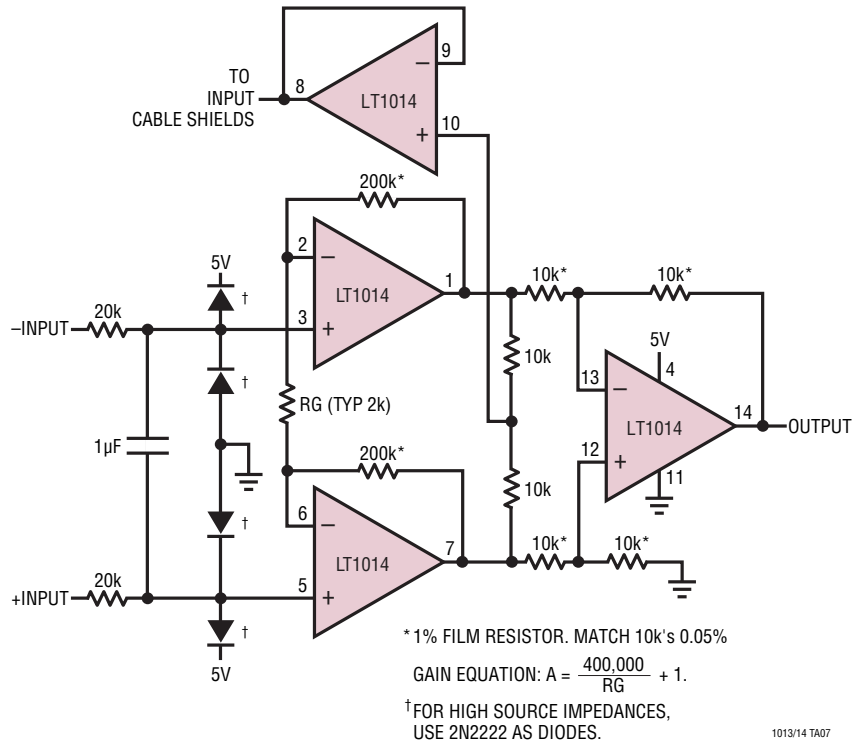

9V Battery Powered Strain Gauge Signal Conditioner

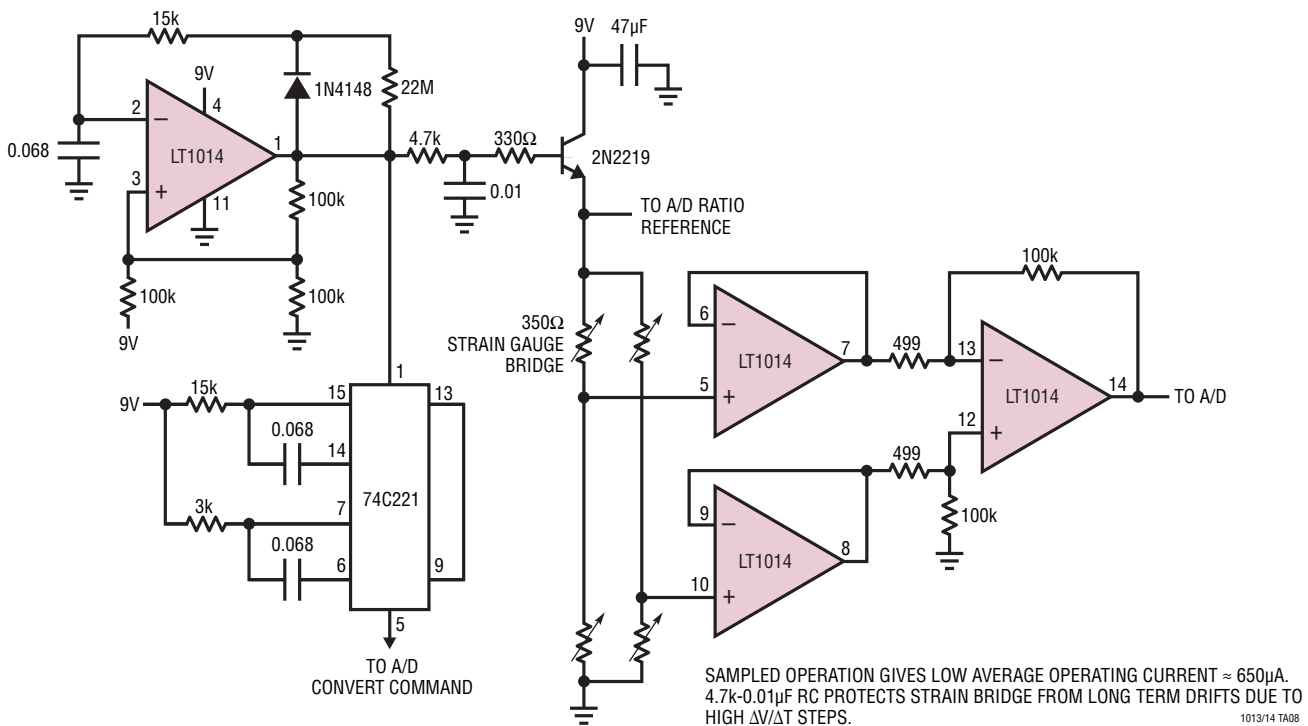

10134fd

## TYPICAL APPLICATIONS

### 5V Powered Motor Speed Controller No Tachometer Required

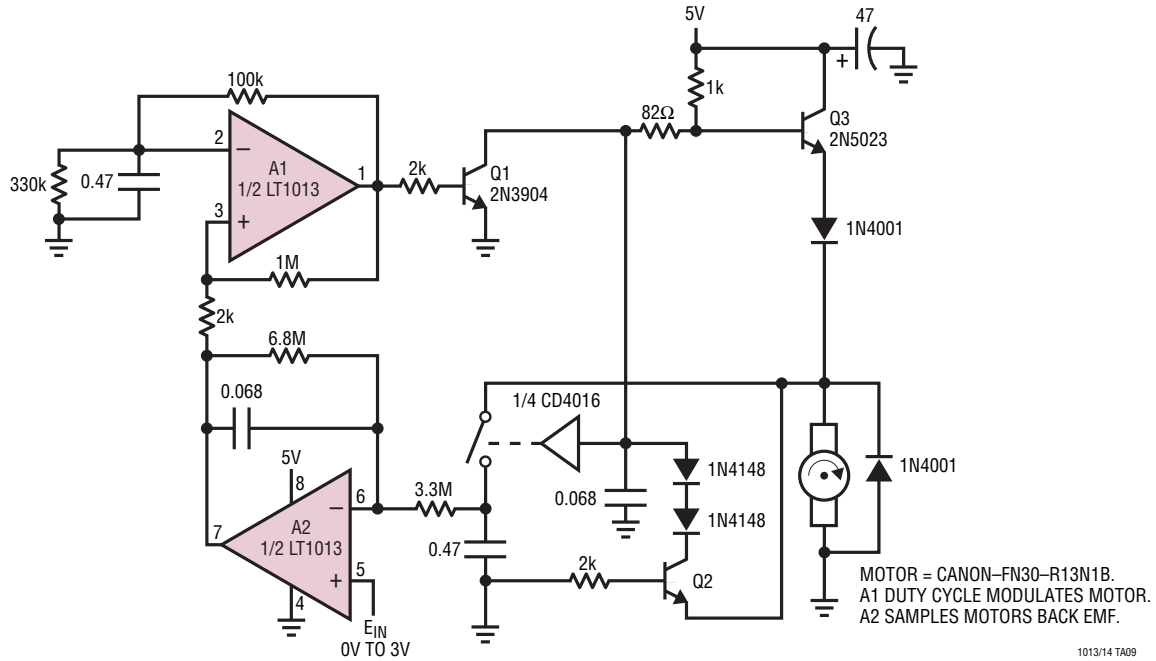

### 5V Powered EEPROM Pulse Generator

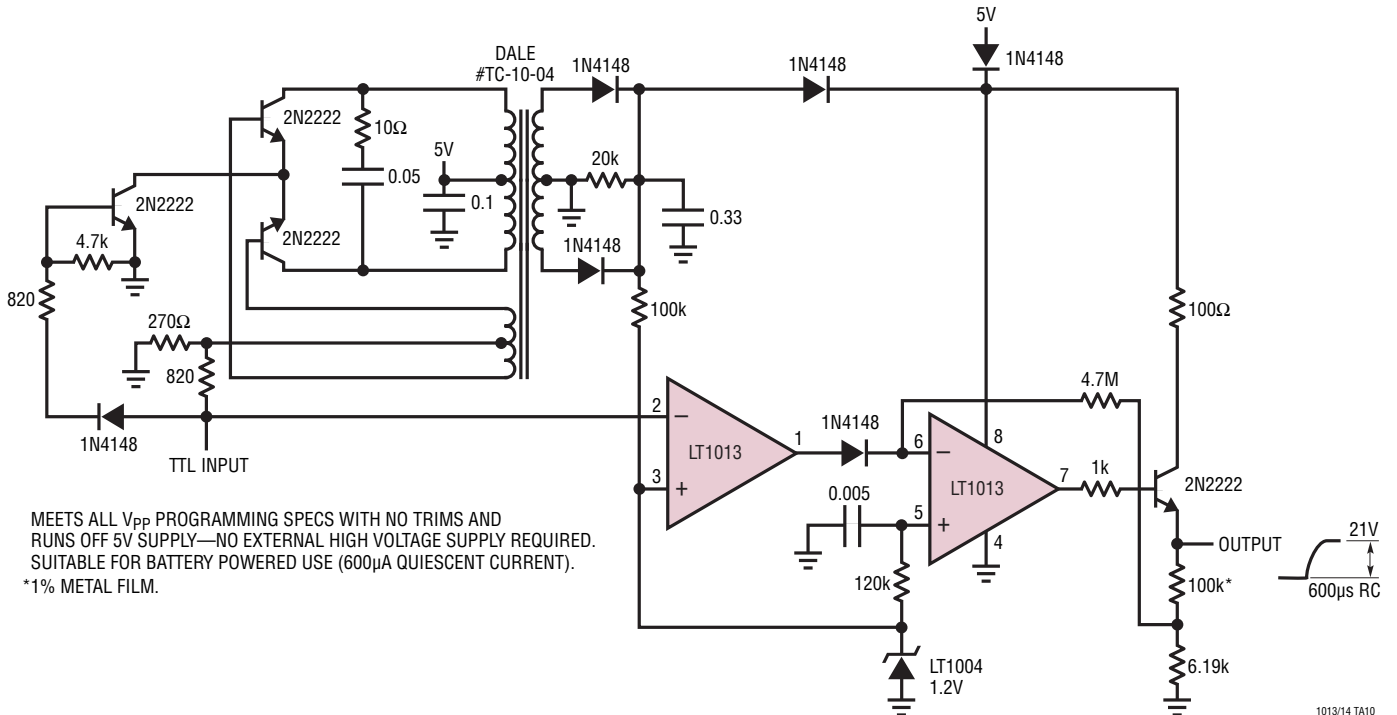

TYPICAL APPLICATIONS

Methane Concentration Detector with Linearized Output

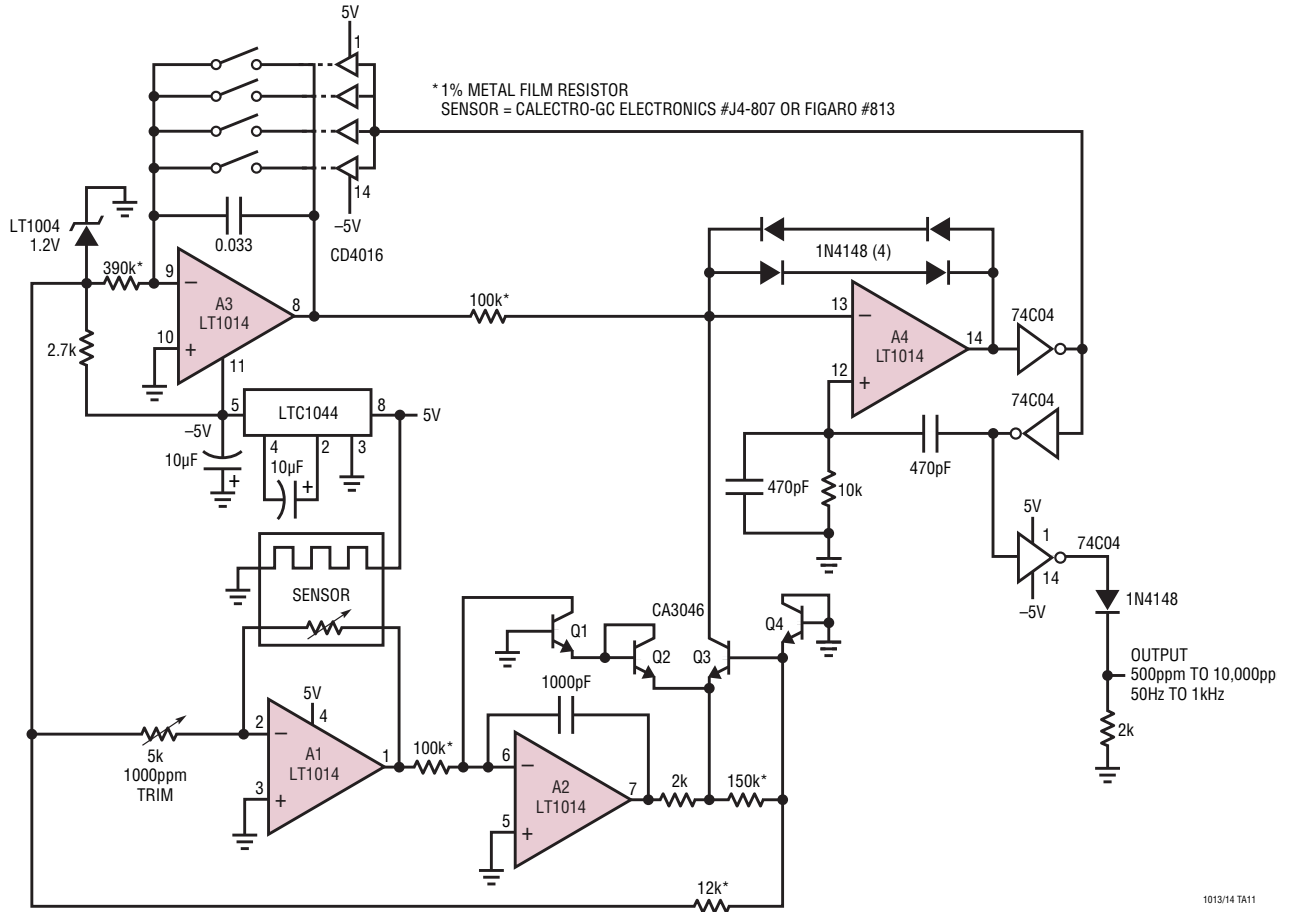

1013/14 TA11

Low Power 9V to 5V Converter

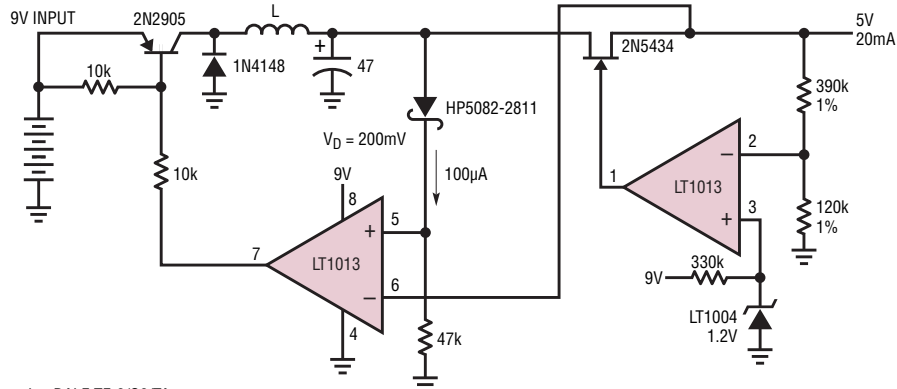

L = DALE TE-3/Q3/TA.  
SHORT CIRCUIT CURRENT = 30mA.  
 $\approx 75\%$  EFFICIENCY.  
SWITCHING PREREGULATOR CONTROLS DROP ACROSS FET TO 200mV.

1013/14 TA12

TYPICAL APPLICATIONS

5V Powered 4mA to 20mA Current Loop Transmitter†

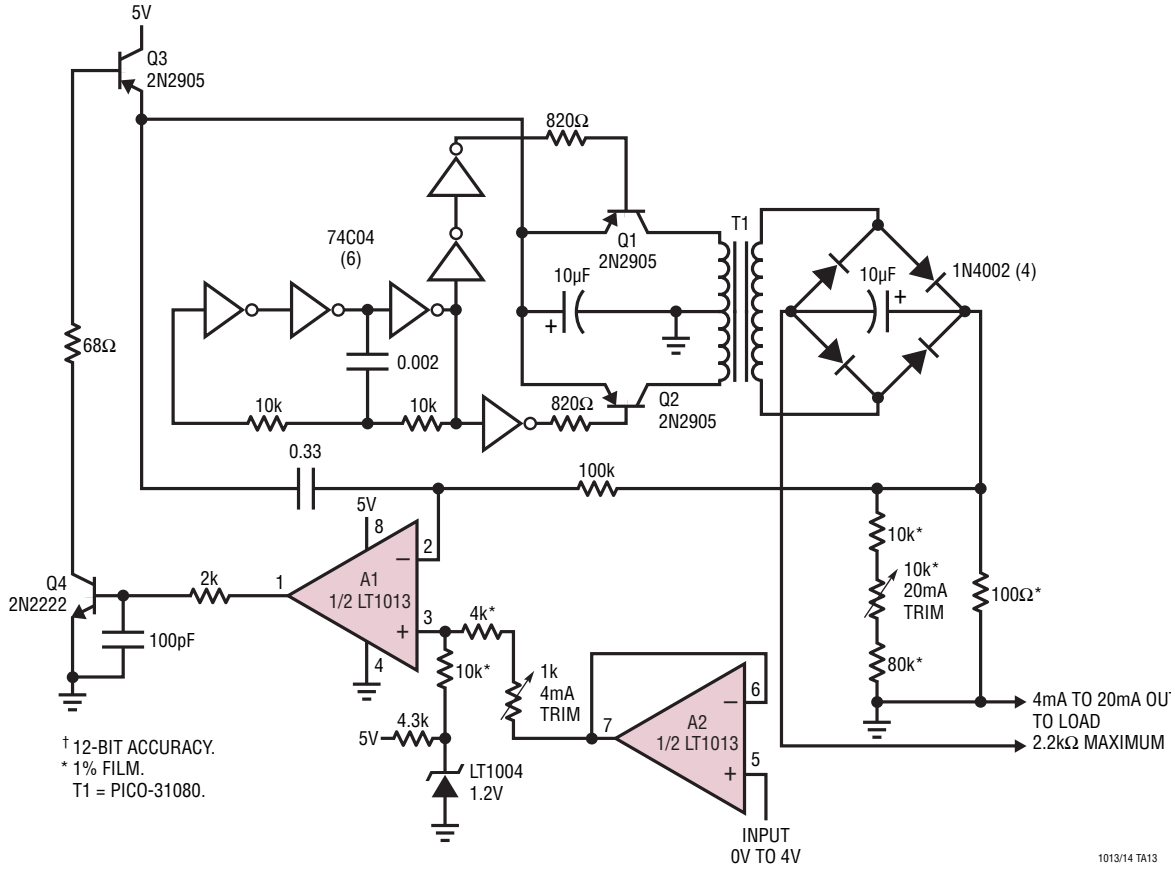

1013/14 TA13

Fully Floating Modification to 4mA-20mA Current Loop†

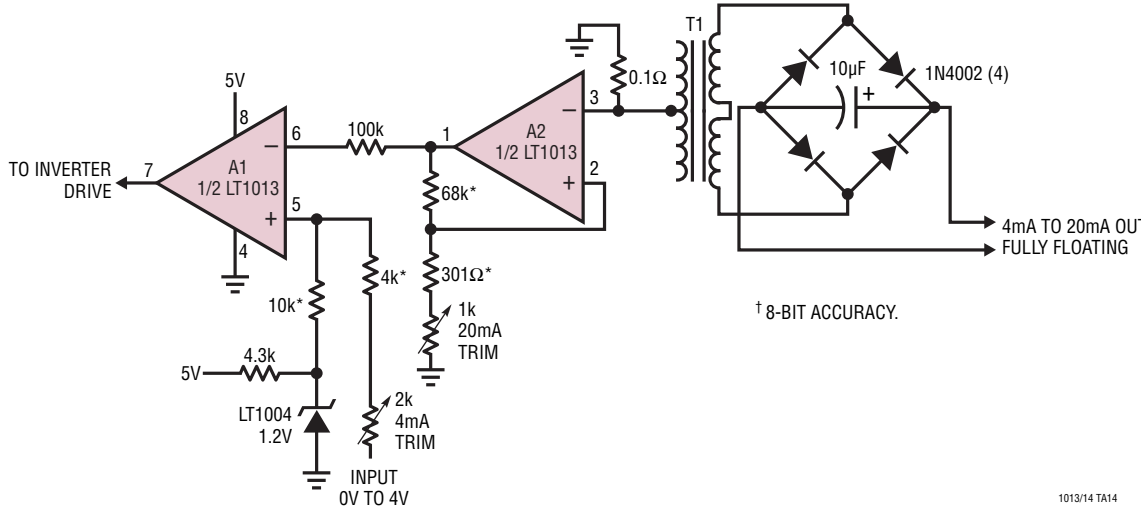

1013/14 TA14

10134fd



# TYPICAL APPLICATIONS

## 5V Powered, Linearized Platinum RTD Signal Conditioner

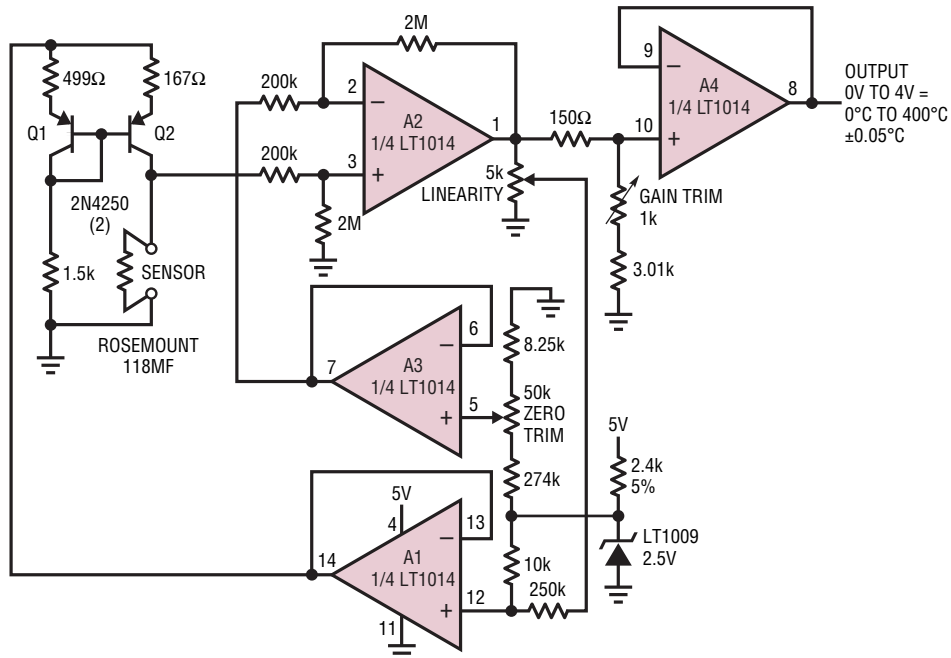

ALL RESISTORS ARE TRW-MAR-6 METAL FILM.  
 RATIO MATCH 2M-200K ± 0.01%.  
 TRIM SEQUENCE:  
 SET SENSOR TO 0° VALUE.  
 ADJUST ZERO FOR 0V OUT.  
 SET SENSOR TO 100°C VALUE.  
 ADJUST GAIN FOR 1.000V OUT.  
 SET SENSOR TO 400°C.  
 ADJUST LINEARITY FOR 4.000V OUT, REPEAT AS REQUIRED.

1013/14 TA15

## Strain Gauge Bridge Signal Conditioner

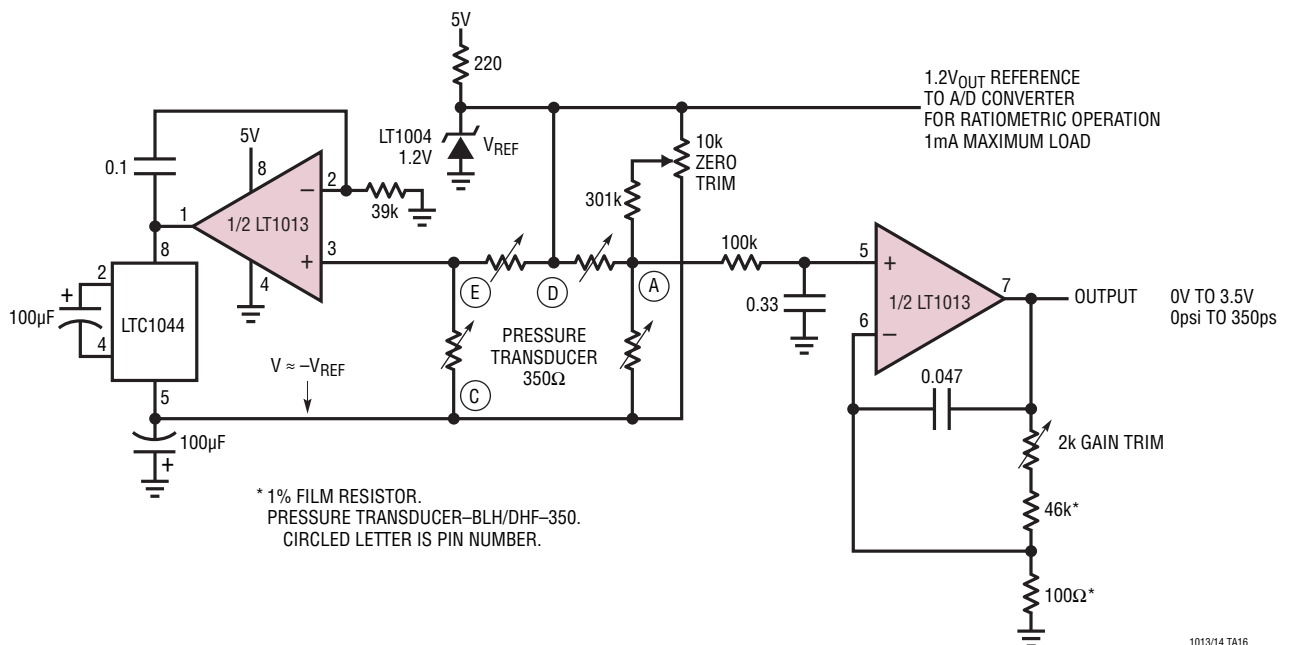

\* 1% FILM RESISTOR.  
 PRESSURE TRANSDUCER-BLH/DHF-350.  
 CIRCLED LETTER IS PIN NUMBER.

1013/14 TA16

10134fd

## TYPICAL APPLICATIONS

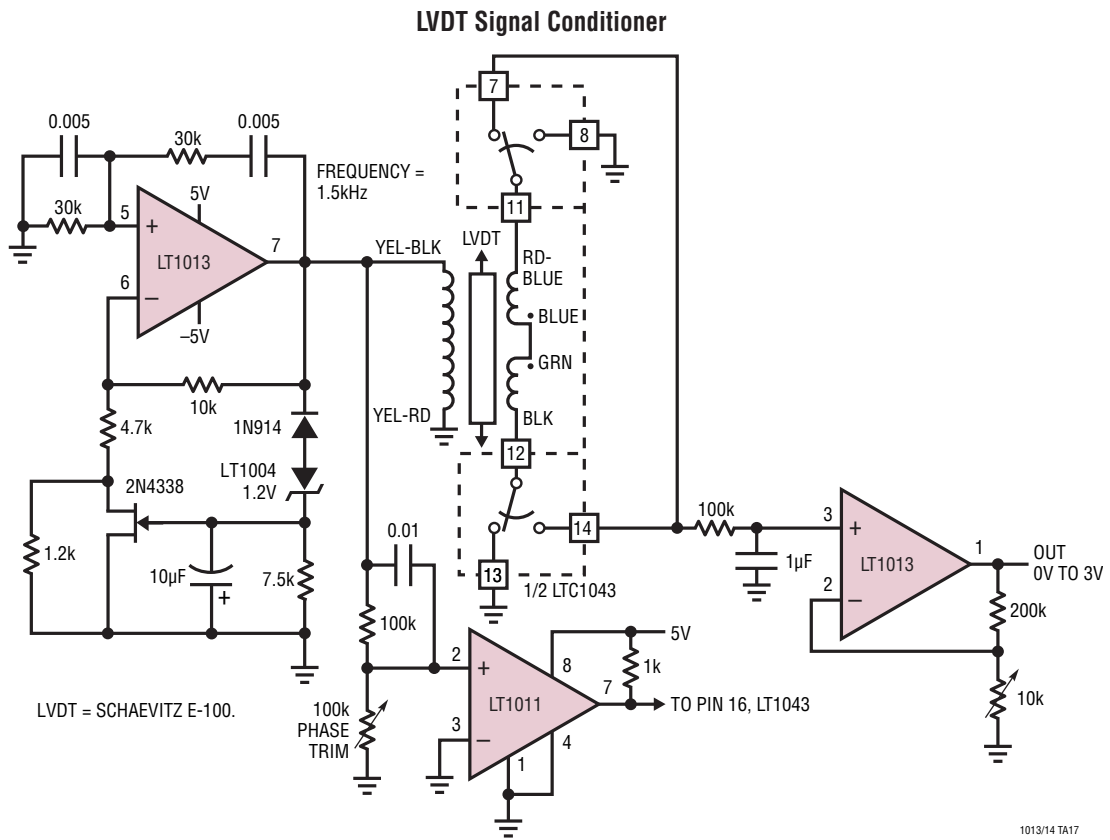

### Triple Op Amp Instrumentation Amplifier with Bias Current Cancellation

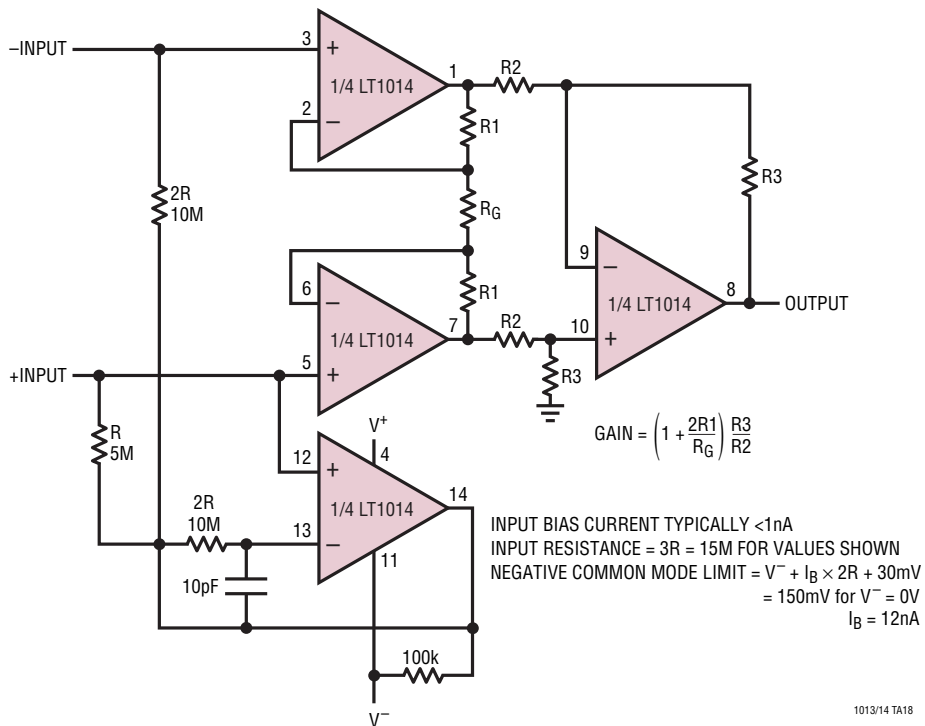

TYPICAL APPLICATIONS

Low Dropout Regulator for 6V Battery

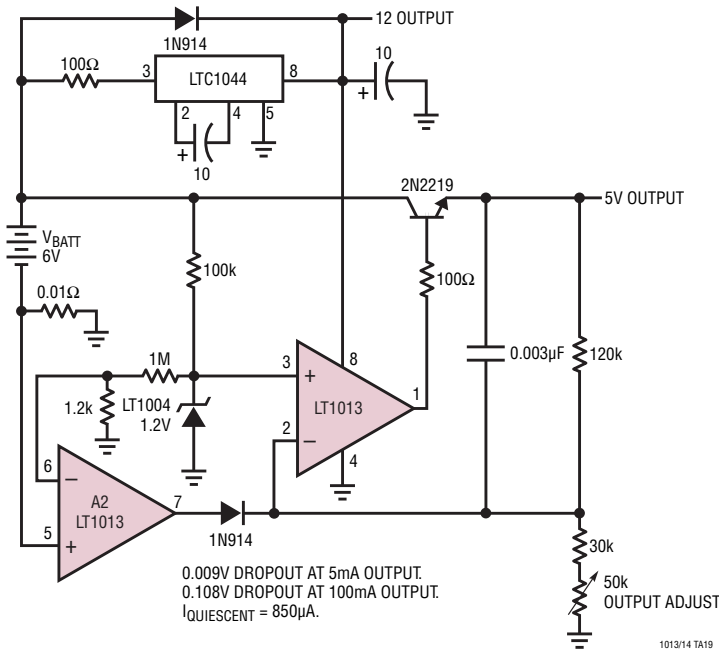

Voltage Controlled Current Source with Ground Referred Input and Output

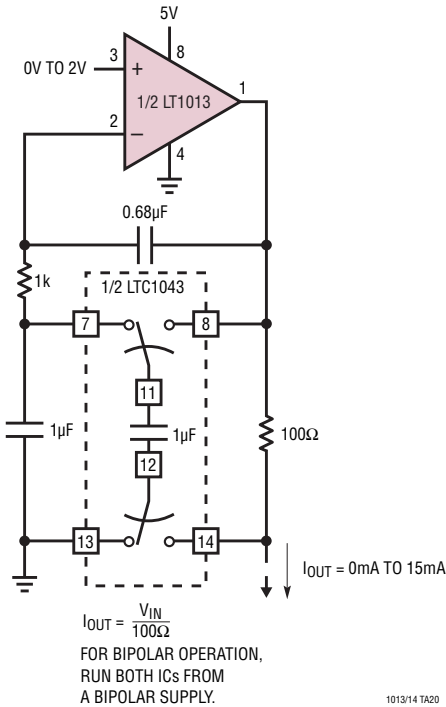

# LT1013/LT1014

## TYPICAL APPLICATIONS

### 6V to ±15V Regulating Converter

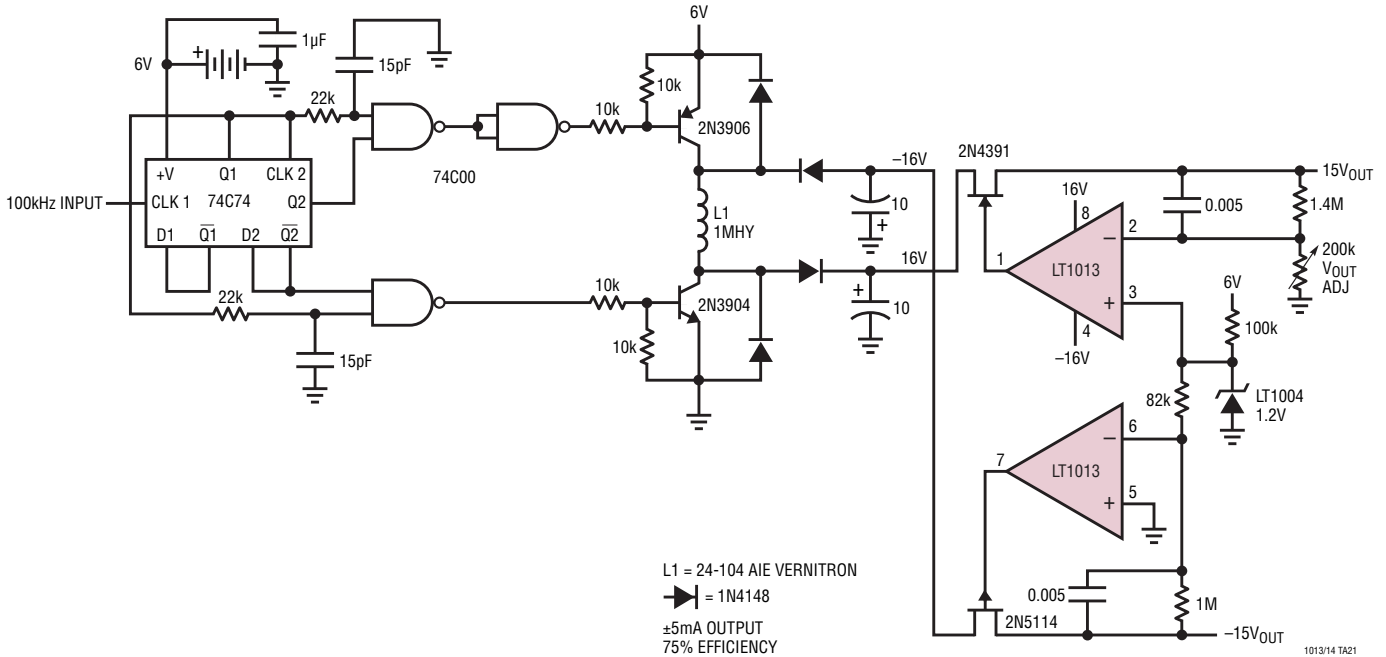

### Low Power, 5V Driven, Temperature Compensated Crystal Oscillator (TXCO)†

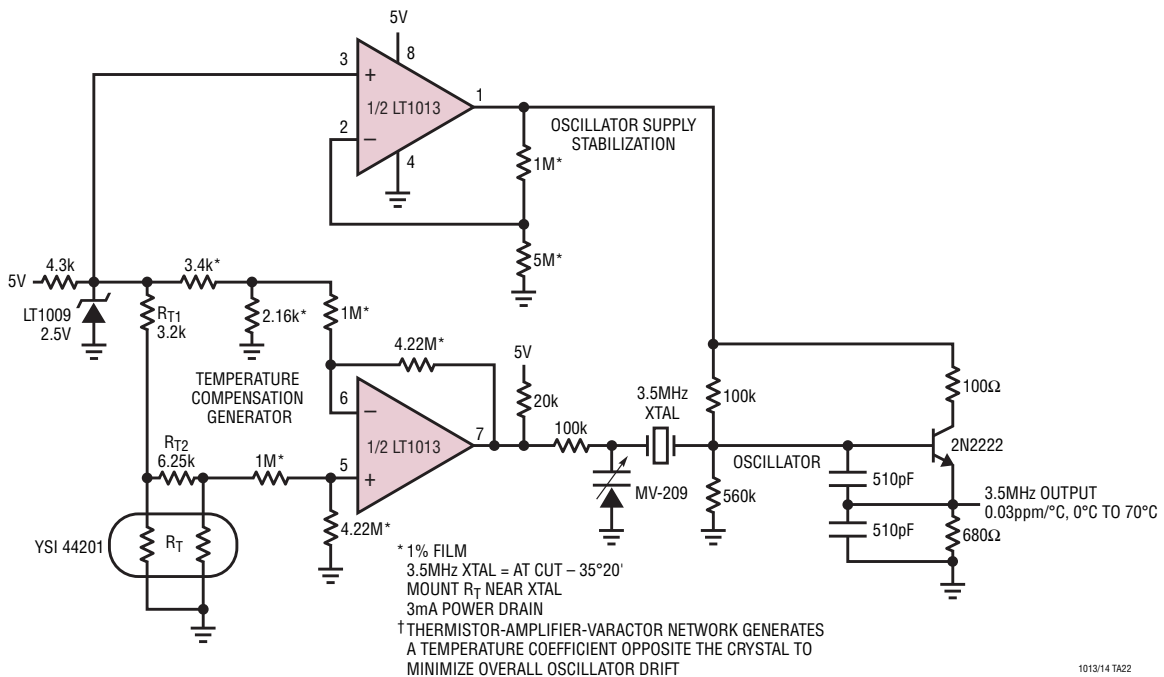

**SCHEMATIC DIAGRAM**

1/2 LT1013, 1/4 LT1014

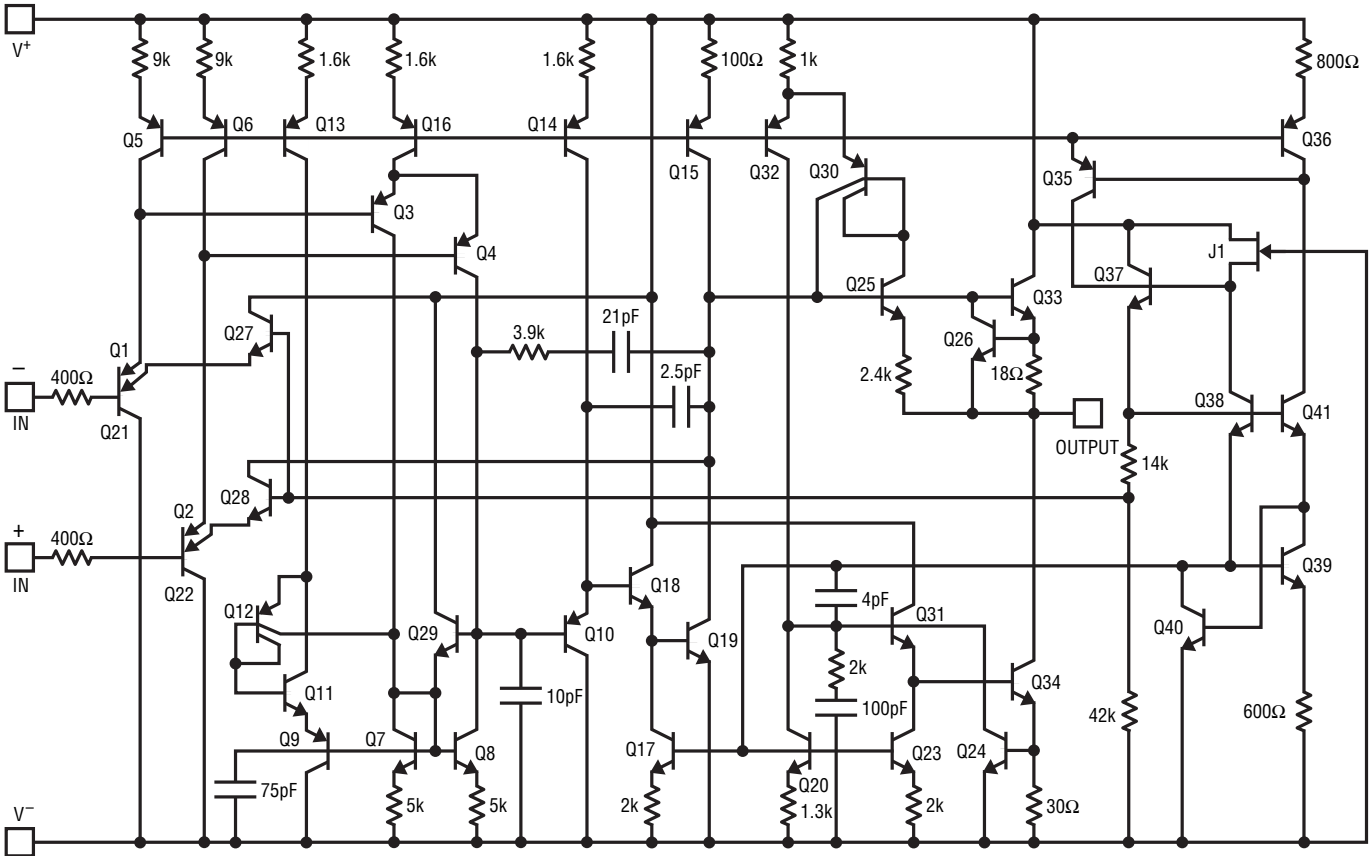

1013/14 SD

**PACKAGE DESCRIPTION**

**H Package**  
**8-Lead TO-5 Metal Can (.200 Inch PCD)**  
 (Reference LTC DWG # 05-08-1320)

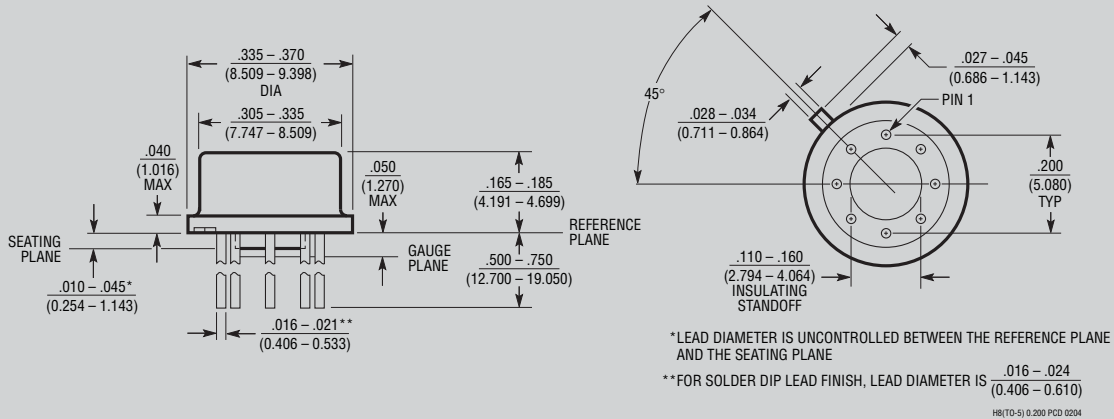

**J8 Package**  
**8-Lead CERDIP (Narrow .300 Inch, Hermetic)**  
 (Reference LTC DWG # 05-08-1110)

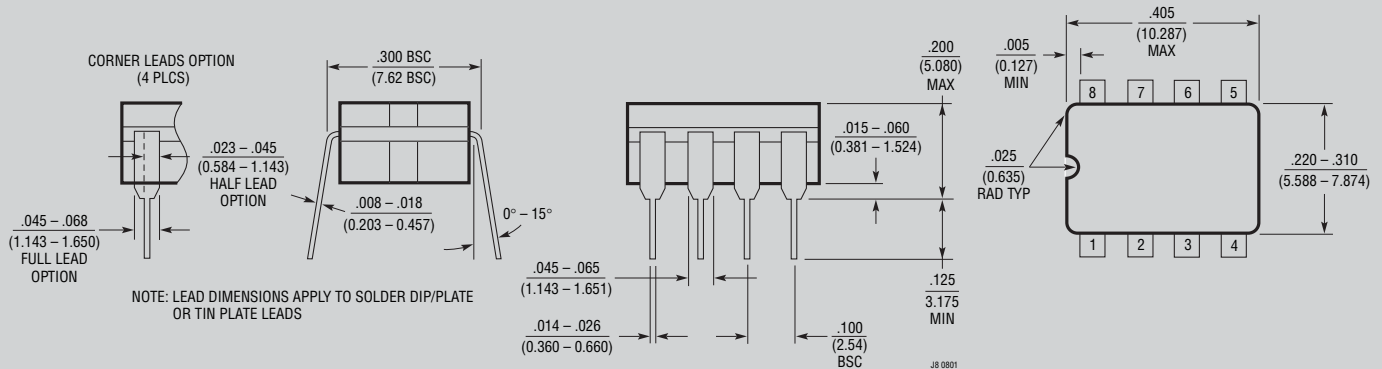

**J Package**  
**14-Lead CERDIP (Narrow .300 Inch, Hermetic)**  
 (Reference LTC DWG # 05-08-1110)

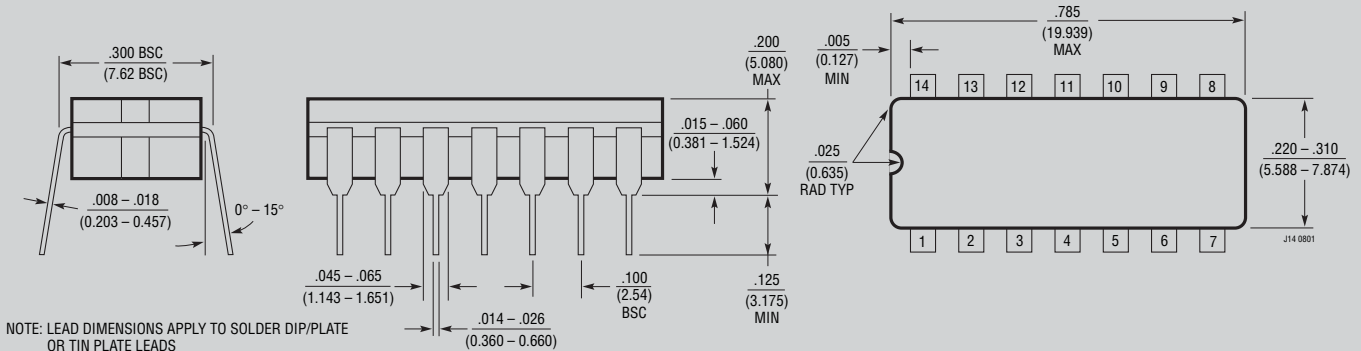

**OBSOLETE PACKAGES**

**PACKAGE DESCRIPTION**

**N8 Package**  
**8-Lead PDIP (Narrow .300 Inch)**  
 (Reference LTC DWG # 05-08-1510)

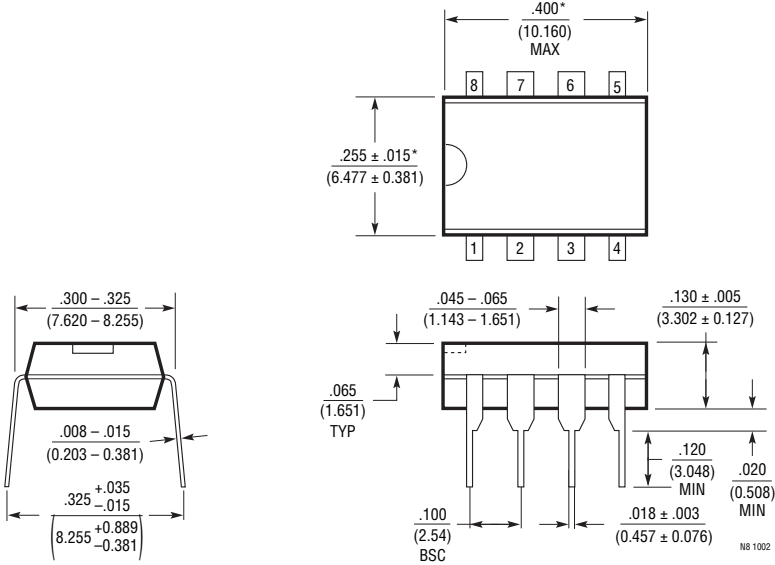

NOTE:  
 1. DIMENSIONS ARE  $\frac{\text{INCHES}}{\text{MILLIMETERS}}$   
 \*THESE DIMENSIONS DO NOT INCLUDE MOLD FLASH OR PROTRUSIONS.  
 MOLD FLASH OR PROTRUSIONS SHALL NOT EXCEED .010 INCH (0.254mm)

**N Package**  
**14-Lead PDIP (Narrow .300 Inch)**  
 (Reference LTC DWG # 05-08-1510)

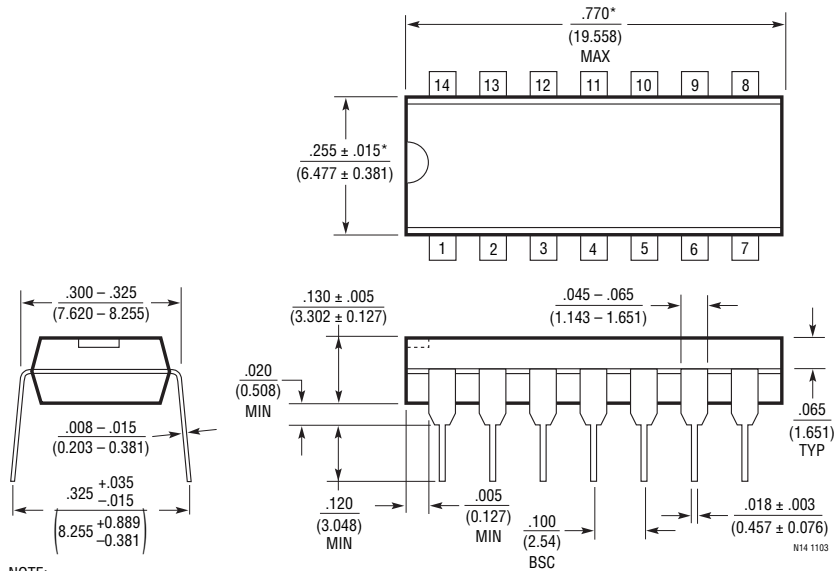

NOTE:  
 1. DIMENSIONS ARE  $\frac{\text{INCHES}}{\text{MILLIMETERS}}$   
 \*THESE DIMENSIONS DO NOT INCLUDE MOLD FLASH OR PROTRUSIONS.  
 MOLD FLASH OR PROTRUSIONS SHALL NOT EXCEED .010 INCH (0.254mm)

## PACKAGE DESCRIPTION

### S6 Package 6-Lead Plastic TSOT-23 (Reference LTC DWG # 05-08-1636)

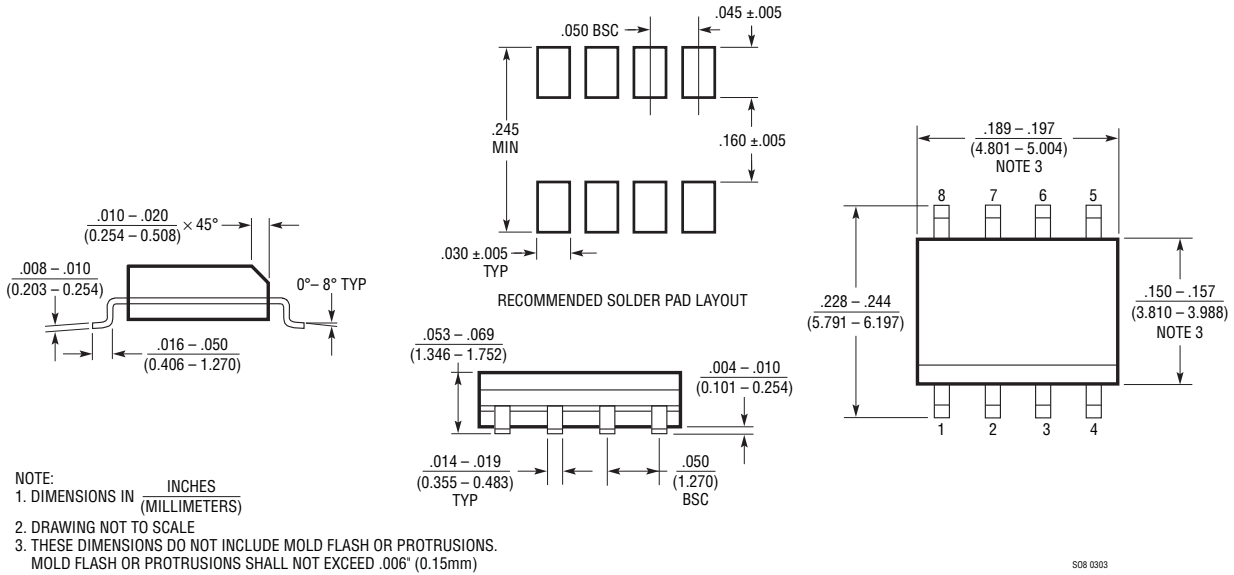

### SW Package XX-Lead Plastic Small Outline (Wide .300 Inch) (Reference LTC DWG # 05-08-1620)

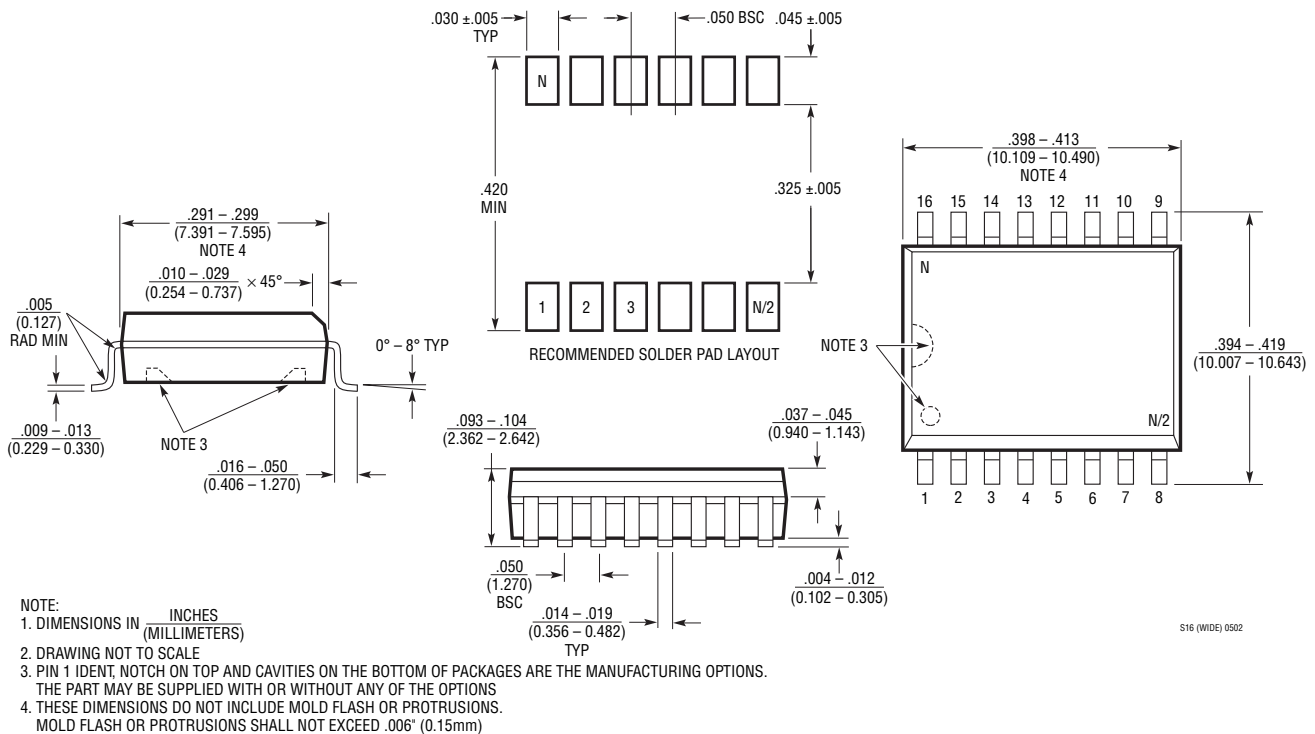



**REVISION HISTORY** (Revision history begins at Rev D)

REV	DATE	DESCRIPTION	PAGE NUMBER
D	05/10	Updates to Typical Application "Hot-Wire Anemometer" Updated Related Parts	12 26

# LT1013/LT1014

## TYPICAL APPLICATION

### Step-Up Switching Regulator for 6V Battery

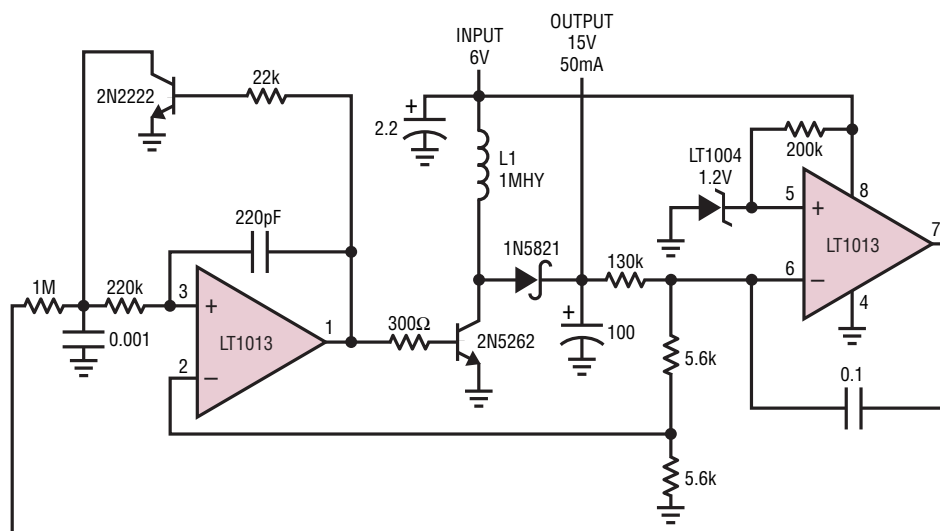

LT = AIE-VERNITRON 24-104  
78% EFFICIENCY

1013/14 TA23

## RELATED PARTS

PART NUMBER	DESCRIPTION	COMMENTS
LT2078/LT2079	Dual/Quad 50 $\mu$ A Single Supply Precision Amplifier	50 $\mu$ A Max $I_S$ , 70 $\mu$ V Max $V_{OS}$
LT2178/LT2179	Dual/Quad 17 $\mu$ A Single Supply Precision Amplifier	17 $\mu$ A Max $I_S$ , 70 $\mu$ V Max $V_{OS}$
LTC6081/LTC6082	Dual/Quad 400 $\mu$ A Precision Rail-to-Rail Amplifier	$V_S = 2.7V$ to 6V, 400 $\mu$ A Max $I_S$ , 70 $\mu$ V $V_{OS}$ 0.8 $\mu$ V/ $^{\circ}$ C $TCV_{OS}$
LTC6078/LTC6079	Dual/Quad 72 $\mu$ A Precision Rail-to-Rail Amplifier	$V_S = 2.7V$ to 6V, 72 $\mu$ A Max $I_S$ , 25 $\mu$ V $V_{OS}$ 0.7 $\mu$ V/ $^{\circ}$ C $TCV_{OS}$

10134fd

26

Linear Technology Corporation  
1630 McCarthy Blvd., Milpitas, CA 95035-7417  
(408) 432-1900 • FAX: (408) 434-0507 • www.linear.com

www.BDTIC.com/Linear

LT 0510 REV D • PRINTED IN USA

**LINEAR**  
TECHNOLOGY

© LINEAR TECHNOLOGY CORPORATION 1990