

1MHz White LED Driver with Output Disconnect and One Pin Current Programming

FEATURES

- Drives Up to Ten White LEDs from a 3V Supply
- One Pin Shutdown and Current Programming
- LEDs Disconnected in Shutdown
- 32:1 Linear Brightness Control Range
- V_{IN} Range: 2.7V to 5.5V
- $\pm 5\%$ Output Current Accuracy at Full Scale
- Low Shutdown Current: 3 μ A
- 1MHz Switching Frequency
- Requires Only 1 μ F Output Capacitor
- Low Profile 6-Lead DFN (2mm \times 2mm \times 0.75mm) and 6-Lead SOT-23 Packages

APPLICATIONS

- Cell Phones
- Digital Cameras
- PDAs, Handheld Computers
- MP3 Players
- GPS Receivers

DESCRIPTION

The LT[®]3593 is a step-up DC/DC converter designed to drive up to ten white LEDs in series from a Li-Ion cell. Series connection of the LEDs provides identical LED currents and eliminates the need for ballast resistors. The device features a unique high side LED current sense that enables the part to function as a “one wire current source” where the low side of the LED string can be returned to ground anywhere.

Additional features include output disconnect in shutdown, open LED protection and 1-pin shutdown/LED current control. The CTRL pin is toggled to adjust the LED current via an internal counter and a 5-bit DAC.

The LT3593 switches at 1MHz, allowing the use of tiny external components. Constant frequency switching results in low input noise and a small output capacitor. The LT3593 is available in the 6-lead DFN (2mm \times 2mm) as well as the 6-lead SOT-23 packages.

LT, LT, LTC and LTM are registered trademarks of Linear Technology Corporation. All other trademarks are the property of their respective owners.

TYPICAL APPLICATION

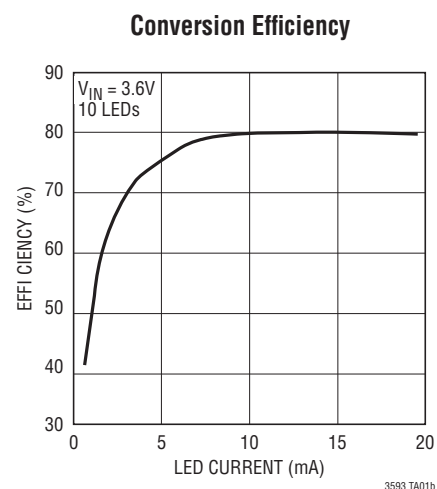
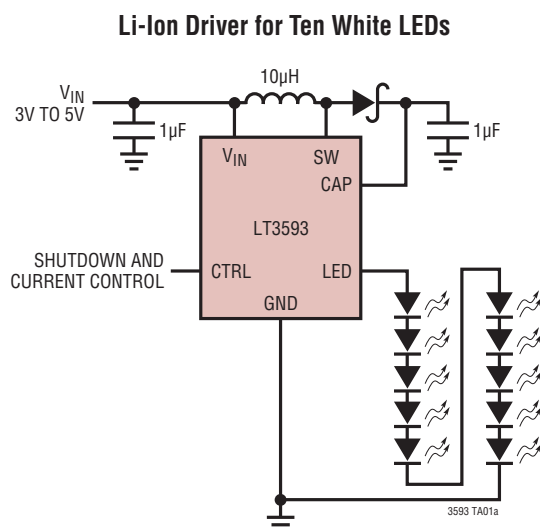

ABSOLUTE MAXIMUM RATINGS (Note 1)

Input Voltage.....	6V	Operating Junction Temperature Range	
CTRL Voltage.....	6V	(Note 2).....	-40°C to 85°C
SW Voltage.....	45V	Maximum Junction Temperature.....	125°C
CAP Voltage.....	45V	Storage Temperature Range.....	-65°C to 150°C
LED Voltage.....	45V	Lead Temperature (Soldering, 10 sec)	
		TSOT Package.....	300°C

PIN CONFIGURATION

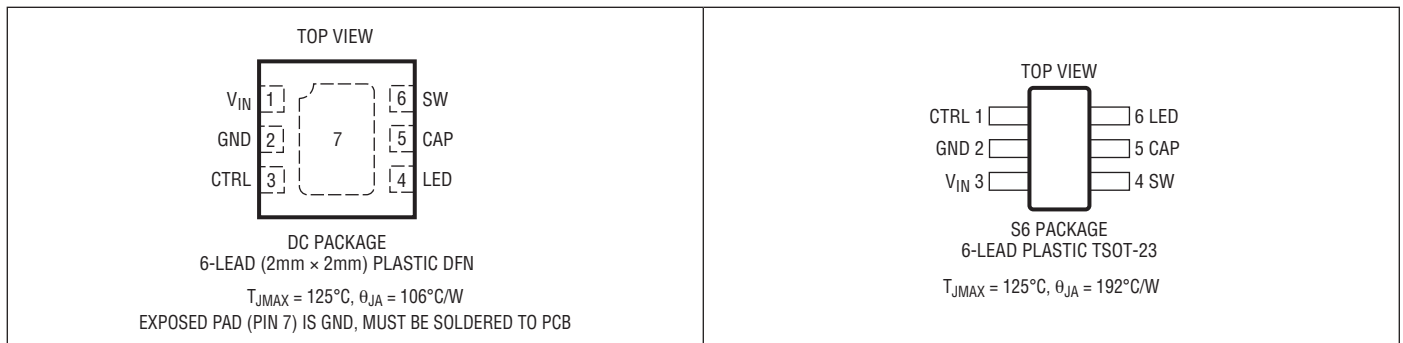

ORDER INFORMATION

LEAD FREE FINISH	TAPE AND REEL	PART MARKING	PACKAGE DESCRIPTION	TEMPERATURE RANGE
LT3593EDC#PBF	LT3593EDC#TRPBF	LDBR	6-Lead (2mm × 2mm) Plastic DFN	-40°C to 85°C
LT3593ES6#PBF	LT3593ES6#TRPBF	LTDBS	6-Lead Plastic TSOT-23	-40°C to 85°C

Consult LTC Marketing for parts specified with wider operating temperature ranges.

Consult LTC Marketing for information on non-standard lead based finish parts.

For more information on lead free part marking, go to: <http://www.linear.com/leadfree/>

For more information on tape and reel specifications, go to: <http://www.linear.com/tapeandreeel/>

ELECTRICAL CHARACTERISTICS

The ● denotes the specifications which apply over the full operating temperature range, otherwise specifications are at $T_A = 25^{\circ}\text{C}$. $V_{IN} = 3.6\text{V}$, $V_{CTRL} = 3.6\text{V}$, unless otherwise specified.

PARAMETER	CONDITIONS	MIN	TYP	MAX	UNITS
Operating Voltage Range		2.7		5.5	V
Supply Current	Not Switching; During Current Programming		300		μA
	CTRL = 0		3	10	μA
Switching Frequency		0.85	1	1.15	MHz
Maximum Duty Cycle		92	94		%
Switch Current Limit		550	700		mA
Switch V_{CESAT}	$I_{SW} = 250\text{mA}$		250		mV

ELECTRICAL CHARACTERISTICS The ● denotes the specifications which apply over the full operating temperature range, otherwise specifications are at $T_A = 25^\circ\text{C}$. $V_{IN} = 3.6\text{V}$, $V_{CTRL} = 3.6\text{V}$, unless otherwise specified.

PARAMETER	CONDITIONS	MIN	TYP	MAX	UNITS	
Switch Leakage Current	$V_{SW} = 30\text{V}$			1	μA	
LED Pin Voltage Drop ($V_{CAP} - V_{LED}$)	$I_{LED} = 20\text{mA}$		250		mV	
LED Pin Leakage Current	$CTRL = 0$, $V_{CAP} = 35\text{V}$			1	μA	
CTRL High Threshold		1.6			V	
CTRL Low Threshold				0.4	V	
CTRL t_{PW}	Programming Pulse Width (Note 3)	250			ns	
CTRL t_{SD}	Time from $CTRL = 0$ to Shutdown	95	128	200	μs	
CTRL t_{EN}	Time from $CTRL = 1$ to Enable	95	128	200	μs	
Full-Scale LED Current	$V_{CAP} = 16\text{V}$ $V_{CAP} = 16\text{V}$		19	20	21	mA
		●	18.5	20	21.5	mA
LED Current Programming Resolution	Linear Increments		625		μA	
LED Current Limit			45		mA	
CTRL Pin Bias Current	$V_{CTRL} = 5.5\text{V}$			1	μA	
Overshoot Protection		●	36	38	40	V

Note 1: Stresses beyond those listed under Absolute Maximum Ratings may cause permanent damage to the device. Exposure to any Absolute Maximum Rating condition for extended periods may affect device reliability and lifetime.

Note 2: The LTC3593E is guaranteed to meet performance specifications from 0°C to 85°C operating junction temperature range. Specifications over the -40°C to 85°C operating junction temperature range are assured by design, characterization and correlation with statistical process controls.

Note 3: Guaranteed by design.

TYPICAL PERFORMANCE CHARACTERISTICS $T_A = 25^\circ\text{C}$ unless otherwise specified.

Switch Saturation Voltage (V_{CESAT})

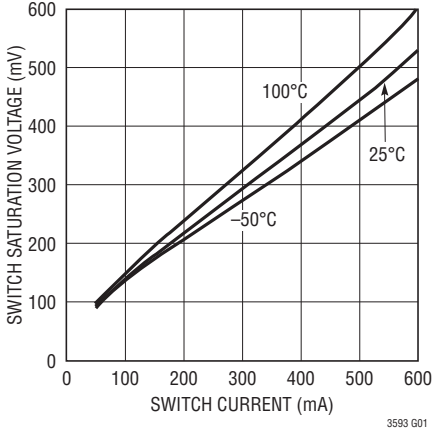

3593 G01

Shutdown Current ($V_{CTRL} = 0\text{V}$)

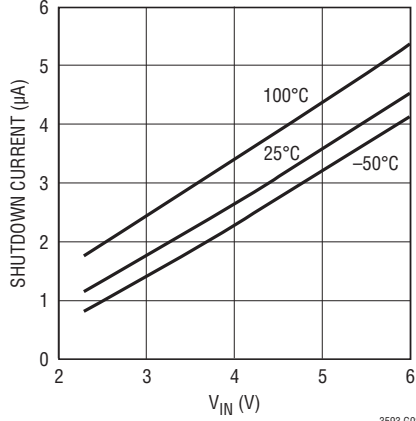

3593 G02

Quiescent Current ($V_{CTRL} = 3.6\text{V}$)

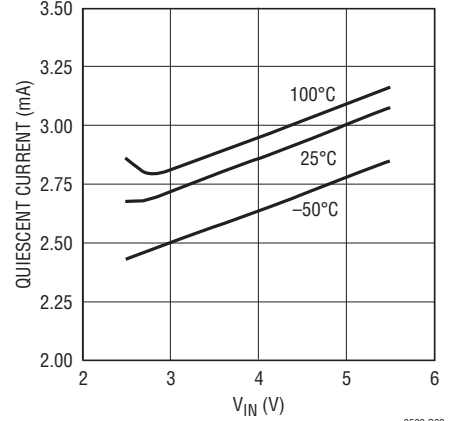

3593 G03

LED Pin Voltage Drop ($V_{CAP} - V_{LED}$)

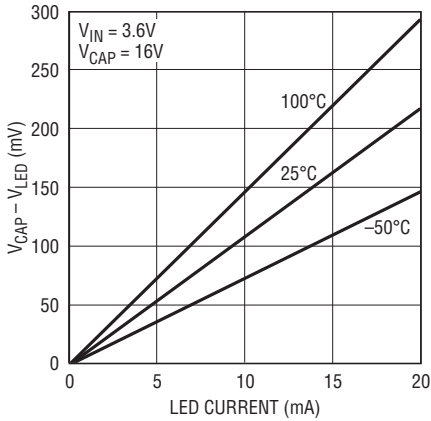

3593 G04

LED Pin Current Limit

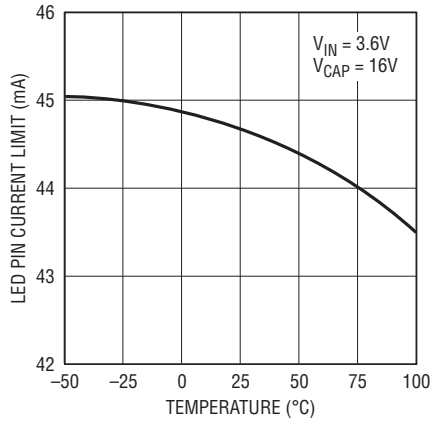

3593 G05

Switching Current Limit vs Temperature

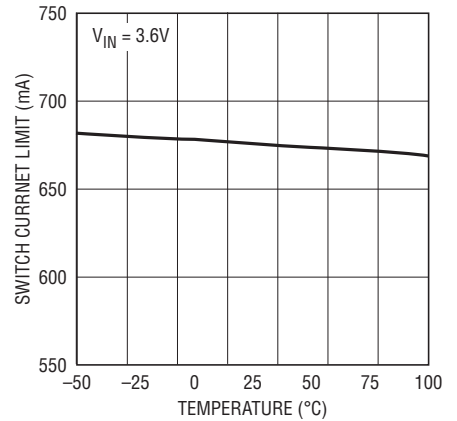

3593 G06

Switching Waveform

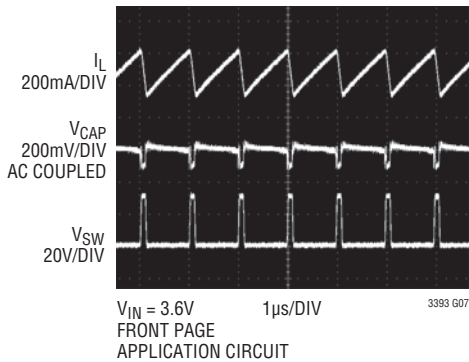

3593 G07

Transient Response

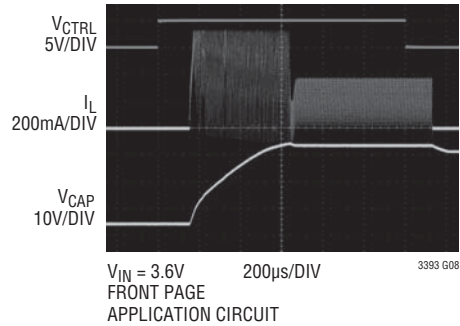

3593 G08

TYPICAL PERFORMANCE CHARACTERISTICS $T_A = 25^\circ\text{C}$ unless otherwise specified.

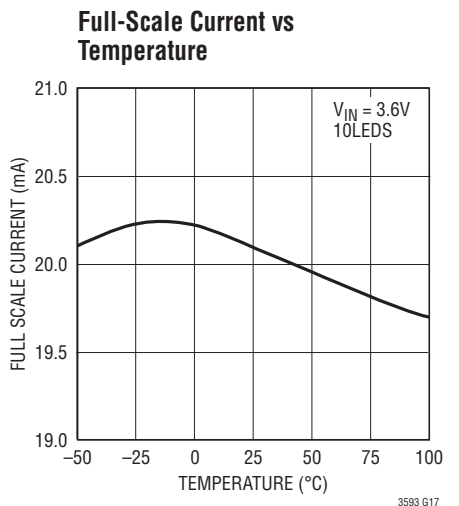
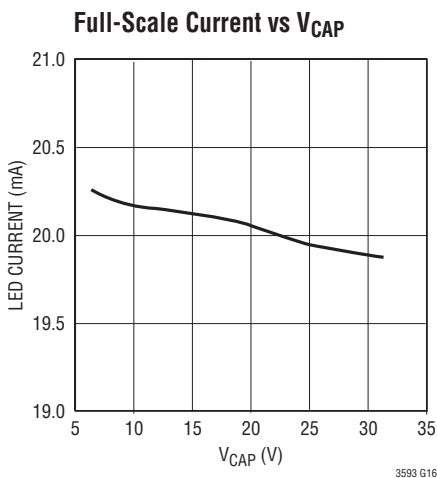
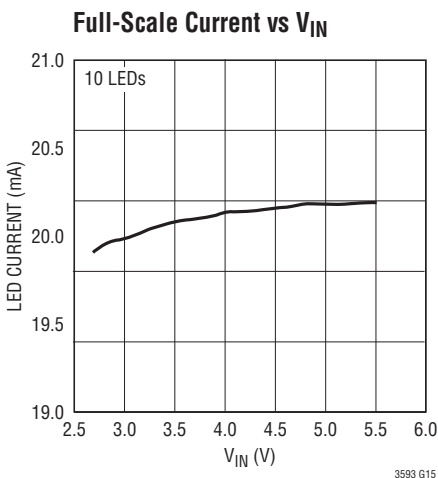
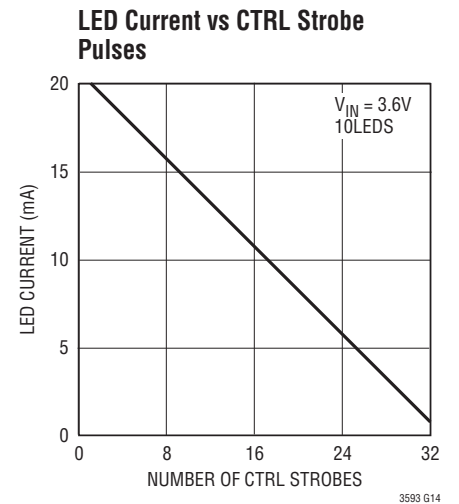
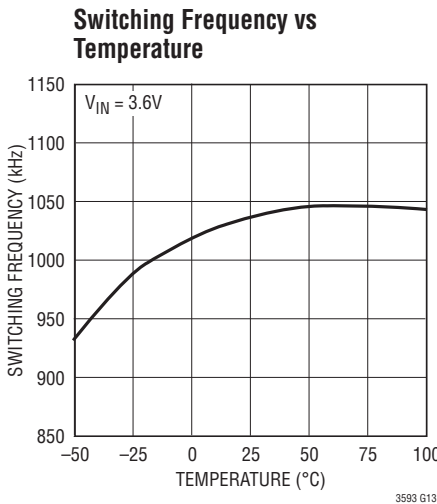
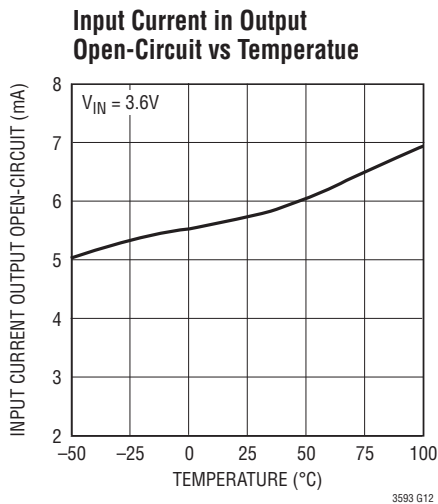
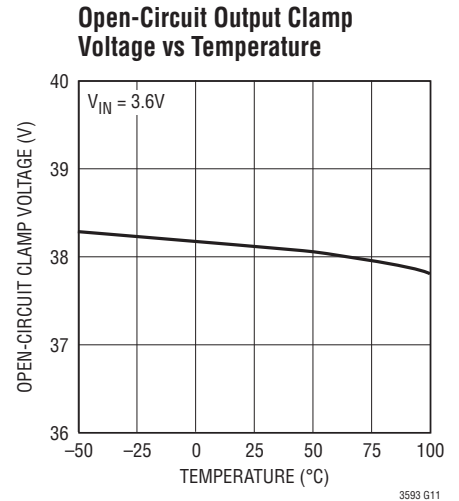
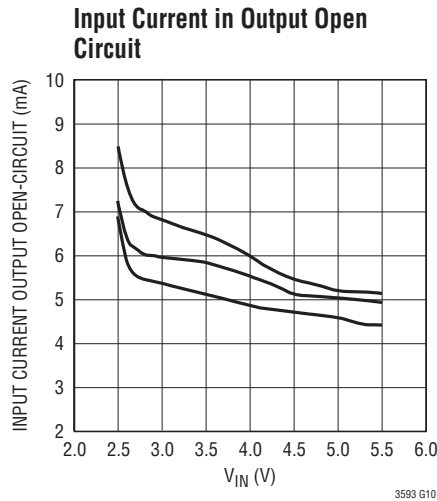
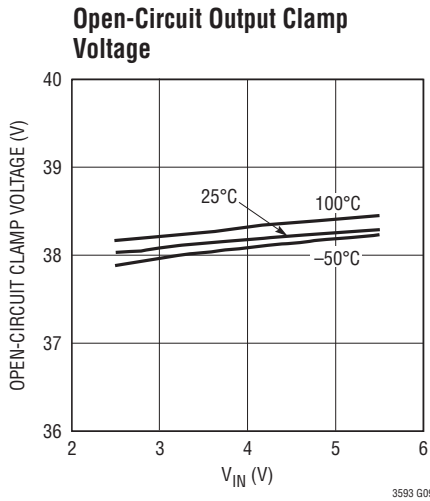

PIN FUNCTIONS (DFN/TSOT)

V_{IN} (Pin 1/Pin 3): Input Supply Pin. Must be locally bypassed with a 1µF X5R or X7R type ceramic capacitor.

GND (Pin 2/Pin 2): Ground Pin. Connect directly to local ground plane.

SW (Pin 6/Pin 4): Switch Pin. Connect inductor between this pin and the V_{IN} pin. Minimize inductance at this pin to minimize EMI.

CAP (Pin 5/Pin 5): Output Pin. Connect to output capacitor. Minimize trace between this pin and output capacitor to reduce EMI.

CTRL (Pin 3/Pin 1): Current Control and Shutdown Pin. This pin is used to program the LED output current. This pin is strobed up to 32 times to decrement the internal 5-bit DACs from full-scale to 1LSB. The counter will stop at 1LSB if the strobing continues beyond 32 counts.

The pin must be held high after the final desired positive strobe edge. The data is transferred after a 128µs (typ) delay. The part can be reprogrammed to a different value after it has been enabled, however the current will change to the new value after 128µs. If CTRL is held low for longer than 128µs (typ), the part will go into shutdown.

LED (Pin 4/Pin 6): LED Pin. An internal switch connects this pin to CAP. The top of the LED string is connected to this pin. When the part is in shutdown, the LED pin is switched off from CAP so no current runs through the LEDs. The switch is also used to sense the LED current when the part is on.

Exposed Pad (Pin 7/NA): Ground. The Exposed Pad must be soldered to the PCB.

BLOCK DIAGRAM

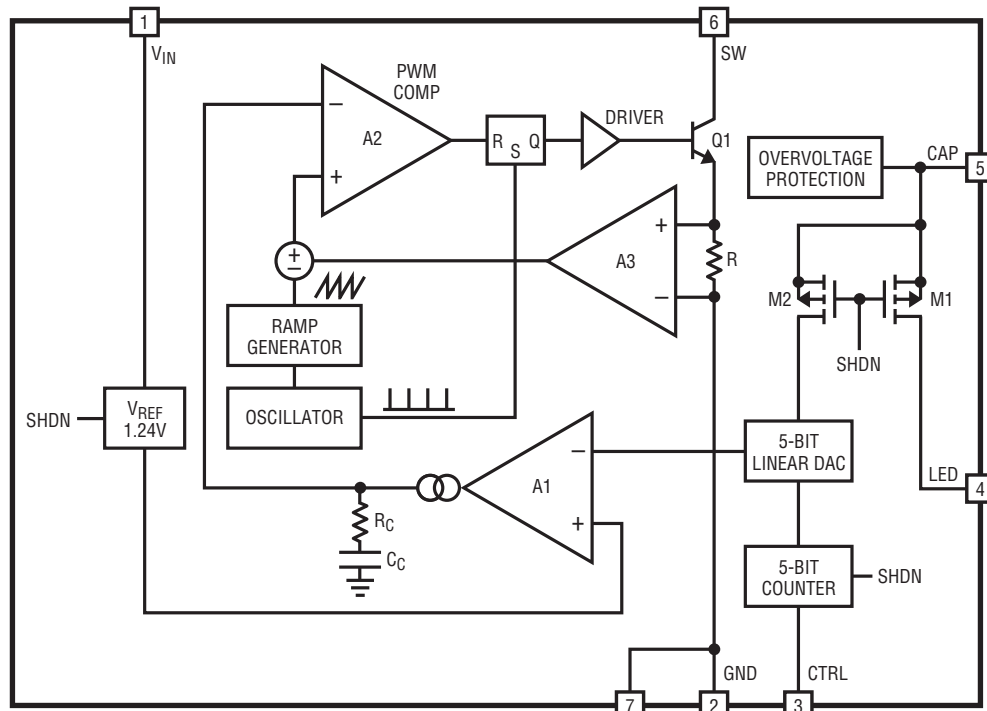

PIN NUMBERS REFER TO DFN PACKAGE. REFER TO PIN CONFIGURATION FOR TSOT PIN NUMBERS

Figure 1. Block Diagram

OPERATION

The LT3593 uses a constant frequency, current mode control boost scheme to provide excellent line and load regulation. Operation can be best understood by referring to the Block Diagram in Figure 1.

Output Disconnect

An internal switch connects between the CAP pin and the LED pin. The top of the LED string is connected to the LED pin. The string can be terminated to ground or to V_{IN} if a low number of LEDs are driven. When the part is in shutdown, the switch is off; allowing no current to run through the LEDs.

Current Programming

The LED current can be set to 32 different values (625 μ A – 20mA) by strobing the CTRL pin. A 5-bit counter is decremented by 1 on a CTRL pin rising edge, reducing the programmed current by 625 μ A each time.

The desired current can be calculated by:

$$I_{LED} = 20mA - (N - 1) \cdot 625\mu A$$

where N is the number of rising edges. When the desired current setting is reached, the CTRL pin must stay high. 128 μ s after the last rising edge on the CTRL pin, the regulator will enable the output and start to regulate the LED current to the programmed value. Figure 2 shows an example of how the part can be programmed.

If a different current is desired, the CTRL pin can be strobed again. The first falling edge will reset the internal register to the 20mA setting. While the new current is being programmed, the device will continue to regulate the previously programmed value until the CTRL pin has remained high for at least 128 μ s, at which time the regulated current will slew to the newly programmed value. Figure 3 shows how to program a new LED current level.

If the CTRL pin is held low for longer than 128 μ s, the part will go into the shutdown mode.

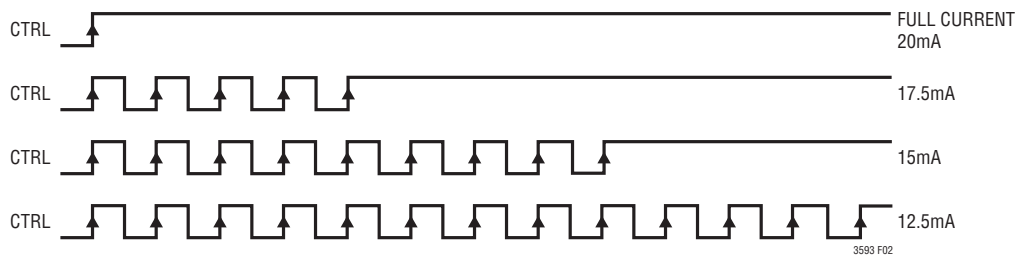

Figure 2. Current Programming

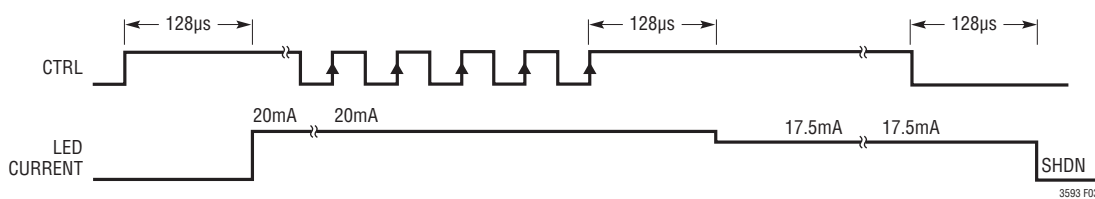

Figure 3. Current Programming and Shutdown Timing

APPLICATIONS INFORMATION

Inductor Selection

A 10 μ H inductor is recommended for most LT3593 applications. Although small size and high efficiency are major concerns, the inductor should have low core losses at 1MHz and low DCR (copper wire resistance). Some inductors in this category with small size are listed in Table 1. The efficiency comparison of different inductors is shown in Figure 4.

Table 1. Recommended Inductors

PART	L (μ H)	DCR (Ω)	CURRENT RATING (mA)	VENDOR
LQH43CN100	10	0.24	650	Murata
LQH32CN100	10	0.44	450	
NR3010T100M	10	0.45	500	Taiyo Yuden
VLF4012AT-100M	10	0.20	500	TDK
VLF3010AT-100M	10	0.58	490	
DE2812-1098AS-100M	10	0.29	580	TOKO
DB3015C-1068AS-100M	10	0.38	400	

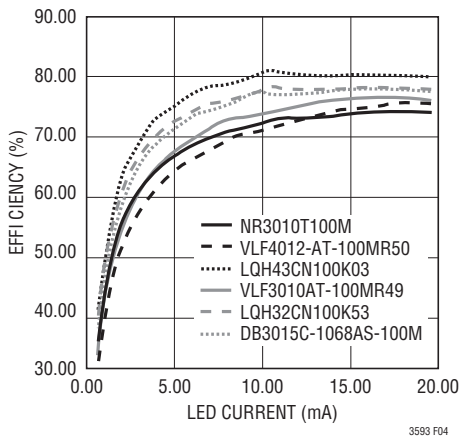

Figure 4. Efficiency Comparison of Different Inductors

Capacitor Selection

The small size of ceramic capacitors makes them ideal for LT3593 applications. Use only X5R and X7R types because they retain their capacitance over wider voltage and temperature ranges than other types such as Y5V or Z5U. A 1 μ F input capacitor and a 1 μ F output capacitor are sufficient for most applications.

Table 2 shows a list of several ceramic capacitor manufacturers. Consult the manufacturers for detailed information on their entire selection of ceramic parts.

Table 2. Recommended Ceramic Capacitor Manufacturers

Taiyo Yuden	(408) 573-4150 www.t-yuden.com
AVX	(803) 448-9411 www.avxcorp.com
Murata	(714) 852-2001 www.murata.com
Kemet	(408) 986-0424 www.kemet.com

Diode Selection

Schottky diodes, with their low forward voltage drop and fast reverse recovery, are the ideal choices for LT3593 applications. The forward voltage drop of a Schottky diode represents the conduction losses in the diode, while the diode capacitance (C_T or C_D) represents the switching losses. For diode selection, both forward voltage drop and diode capacitance need to be considered. Schottky diodes with higher current ratings usually have lower forward voltage drop and larger diode capacitance, which can cause significant switching losses at the 1.0MHz switching frequency of the LT3593. A Schottky diode rated at 400mA to 500mA is sufficient for most LT3593 applications. Some recommended Schottky diodes are listed in Table 3.

Table 3. Recommended Schottky Diodes

PART NUMBER	FORWARD CURRENT (mA)	VOLTAGE DROP (V)	DIODE CAPACITANCE (pF)	MANUFACTURER
CMDSH05-4	500	0.47 at 500mA	50 at 1V	Central 631-435-1110 www.centalsemi.com
CMMSH1-40	1000	0.55 at 1A	80 at 4V	
ZLL5400	520	0.50 at 400mA	15 at 30V	Zetex 631-543-7100 www.zetex.com
PMEG-4005AEA	500	0.47 at 500mA	50 at 1V	Phillips +3140 27 24825 www.semiconductors.phillips.com

APPLICATIONS INFORMATION

Overvoltage Protection

The LT3593 has an internal open-circuit protection circuit. In the case of an output open circuit, when the LEDs are disconnected from the circuit or the LEDs fail open, V_{CAP} is clamped at 38V. The LT3593 will then switch at a very low frequency to minimize input current. V_{CAP} and input current during output open circuit are shown in the Typical Performance Characteristics. Figure 5 shows the transient response when the LEDs are disconnected.

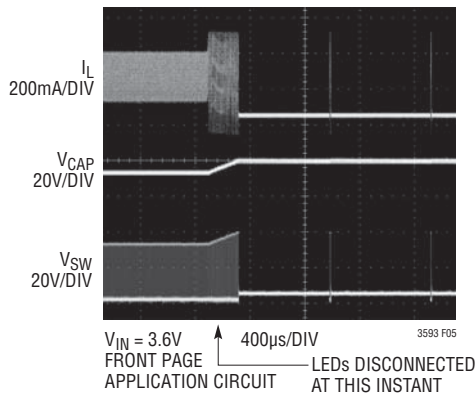

Figure 5. Output Open-Circuit Waveform

Low Input Voltage Applications

The LT3593 can be used in low input voltage applications. The input supply voltage to the LT3593 must be 2.7V or higher, but the inductor can be run off a lower battery voltage. This technique allows the LEDs to be powered off two alkaline cells. Most portable devices have a 3.3V logic supply voltage which can be used to power the LT3593. The LEDs can be driven straight from the battery, resulting in higher efficiency.

Figure 6 shows three LEDs powered by two AA cells. The battery is connected to the inductors and the chip is powered off a 3.3V logic supply voltage.

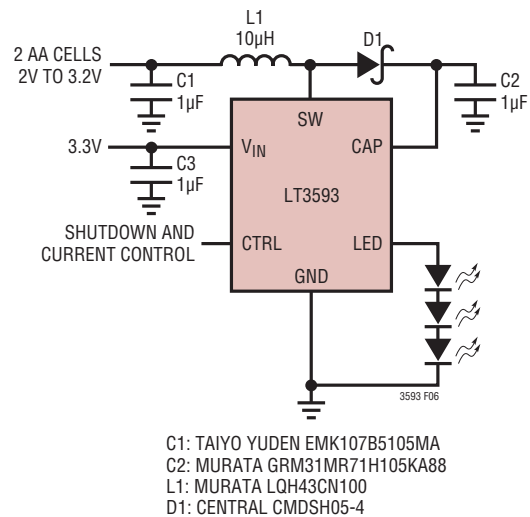

Figure 6. Two AA Cells to Three White LEDs

APPLICATIONS INFORMATION

Board Layout Considerations

As with all switching regulators, careful attention must be paid to the PCB layout and component placement. To prevent electromagnetic interference (EMI) problems, proper layout of high frequency switching paths is essential. Minimize the length and area of all traces connected to the

Switching node pin (SW). Keep the sense voltage pins (CAP and LED) away from the switching node. Place C2 next to the CAP pin. Always use a ground plane under the switching regulator to minimize interplane coupling. Recommended component placement is shown in Figure 7.

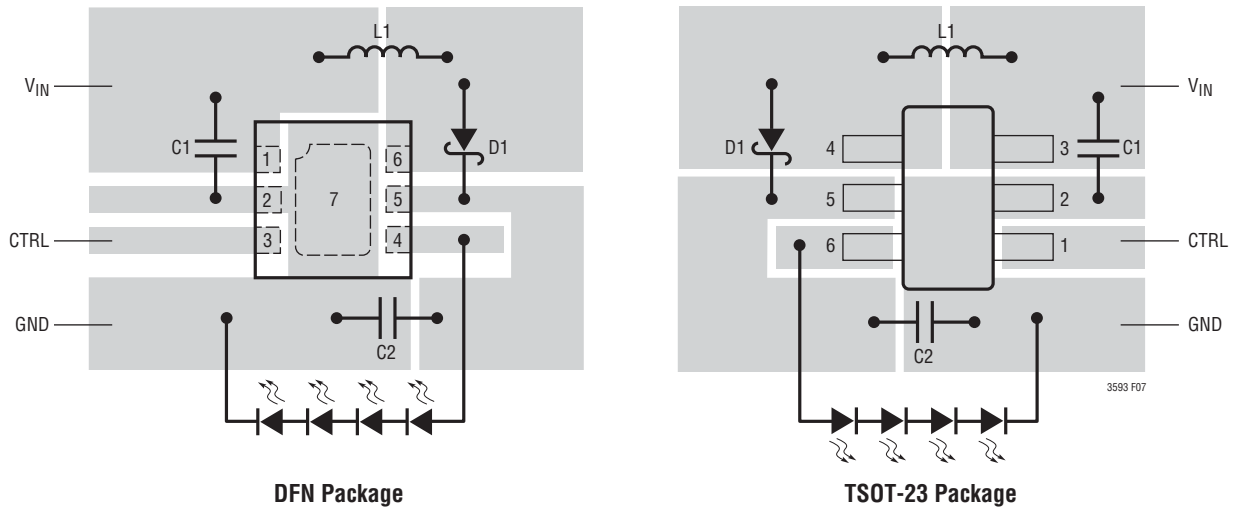
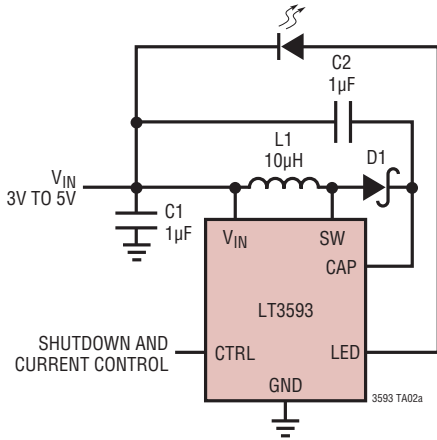

Figure 7. Recommended Component Placement

TYPICAL APPLICATIONS

Li-Ion Driver for One White LED



- C1: TAIYO YUDEN EMK107BJ105MA
- C2: TAIYO YUDEN GMK316BJ105ML
- L1: MURATA LQH43CN100
- D1: CENTRAL CMDSH05-4

Conversion Efficiency

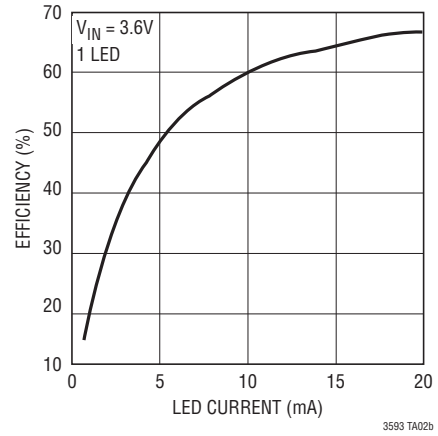

Li-Ion Driver for Two White LED

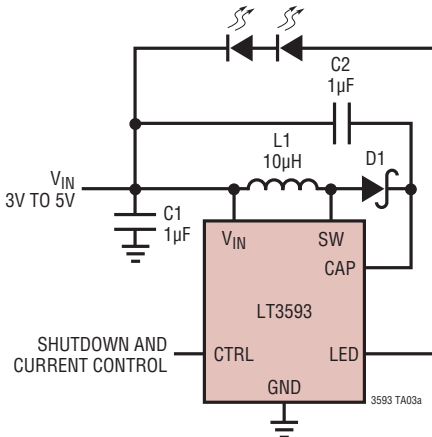

- C1: TAIYO YUDEN EMK107BJ105MA
- C2: TAIYO YUDEN GMK316BJ105ML
- L1: MURATA LQH43CN100
- D1: CENTRAL CMDSH05-4

Conversion Efficiency

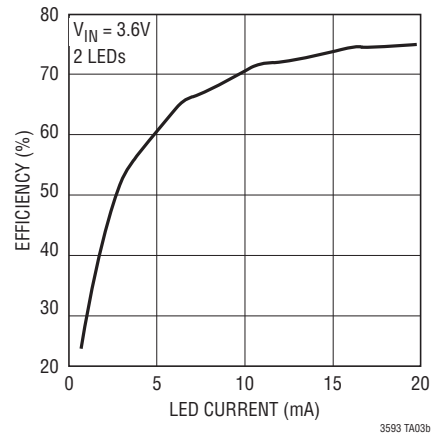

TYPICAL APPLICATIONS

Li-Ion Driver for Three White LEDs

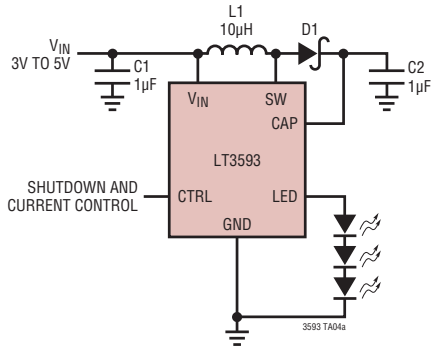

C1: TAIYO YUDEN EMK107BJ105MA
 C2: TAIYO YUDEN GMK316BJ105ML
 L1: MURATA LQH43CN100
 D1: CENTRAL CMDSH05-4

Efficiency

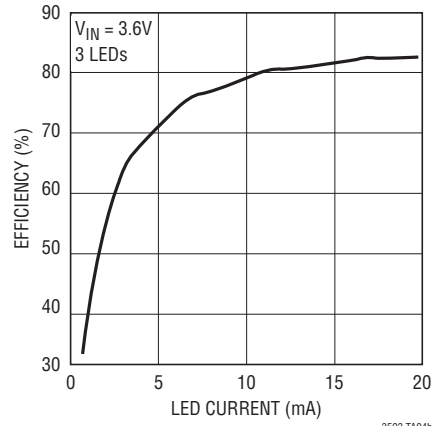

Li-Ion Driver for Four White LEDs

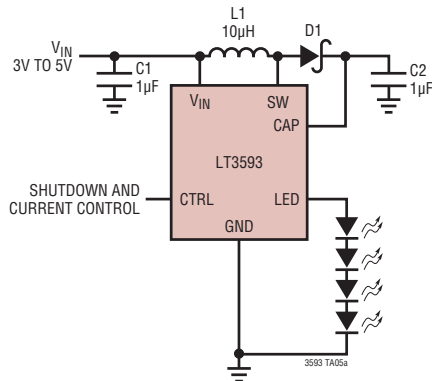

C1: TAIYO YUDEN EMK107BJ105MA
 C2: TAIYO YUDEN GMK316BJ105ML
 L1: MURATA LQH43CN100
 D1: CENTRAL CMDSH05-4

Efficiency

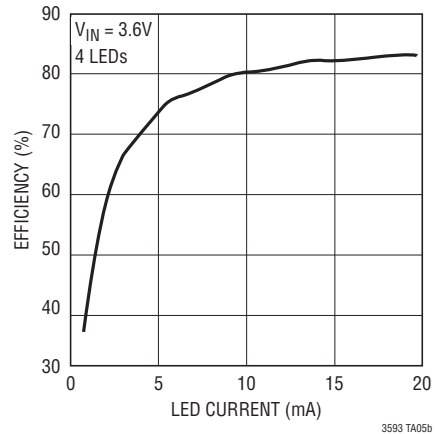

Li-Ion Driver for Six White LEDs

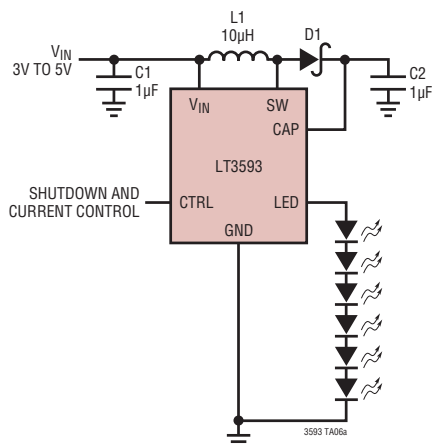

C1: TAIYO YUDEN EMK107BJ105MA
 C2: TAIYO YUDEN GMK316BJ105ML
 L1: MURATA LQH43CN100
 D1: CENTRAL CMDSH05-4

Efficiency

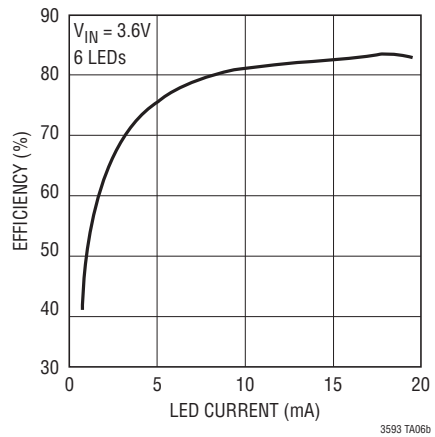

TYPICAL APPLICATIONS

Li-Ion Driver For Ten White LEDs

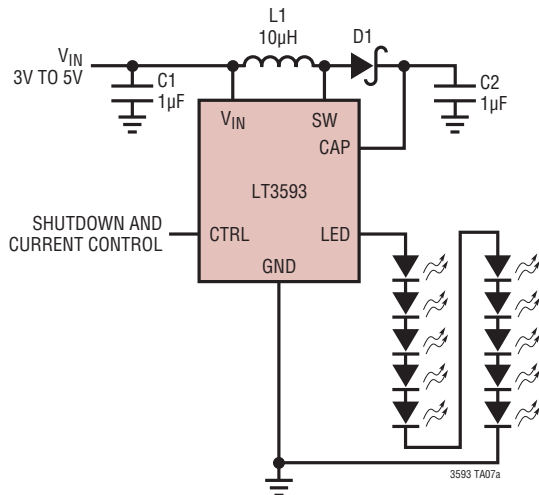

- C1: TAIYO YUDEN EMK107BJ105MA
- C2: MURATA GRM31MR71H105KA88
- L1: MURATA LQH43CN100
- D1: CENTRAL CMDSH05-4

Efficiency

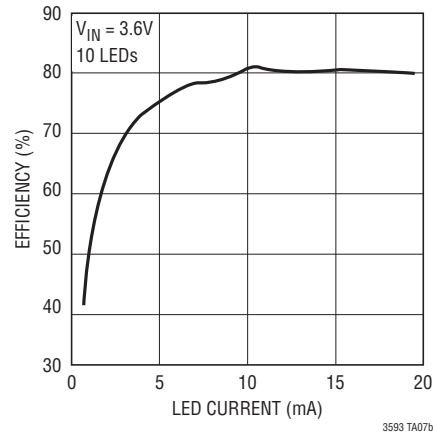

Li-Ion Driver For Ten White LEDs

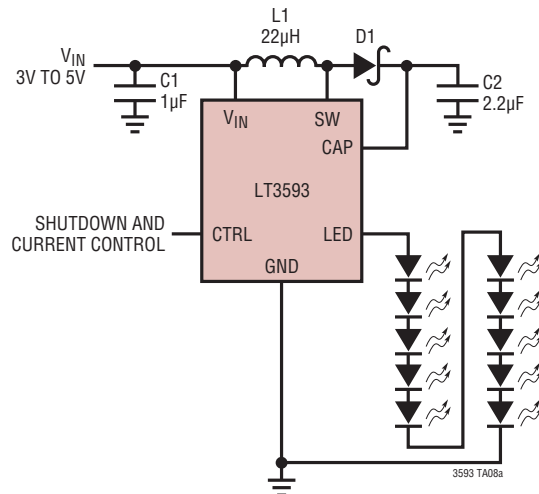

- C1: TAIYO YUDEN EMK107BJ105MA
- C2: MURATA GRM31CR71H225KA88
- L1: MURATA LQH43CN220
- D1: CENTRAL CMDSH05-4

Efficiency

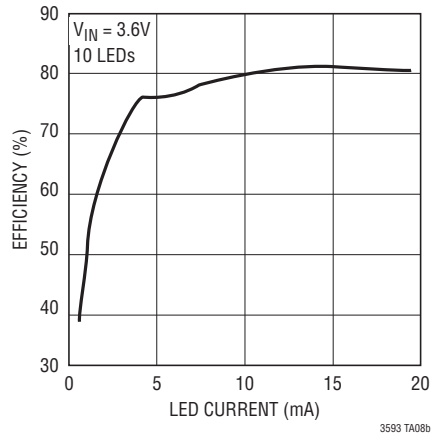

PACKAGE DESCRIPTION

DC Package
6-Lead Plastic DFN (2mm × 2mm)
 (Reference LTC DWG # 05-08-1703)

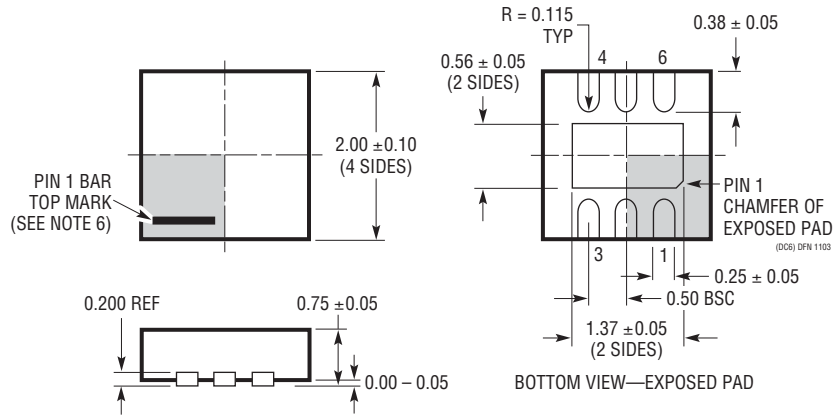
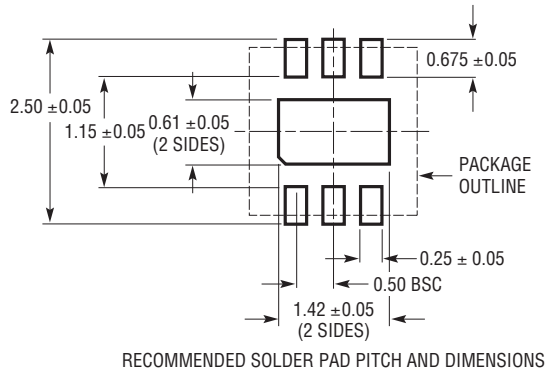

- NOTE:
1. DRAWING TO BE MADE A JEDEC PACKAGE OUTLINE M0-229 VARIATION OF (WCCD-2)
 2. DRAWING NOT TO SCALE
 3. ALL DIMENSIONS ARE IN MILLIMETERS
 4. DIMENSIONS OF EXPOSED PAD ON BOTTOM OF PACKAGE DO NOT INCLUDE MOLD FLASH. MOLD FLASH, IF PRESENT, SHALL NOT EXCEED 0.15mm ON ANY SIDE
 5. EXPOSED PAD SHALL BE SOLDER PLATED
 6. SHADED AREA IS ONLY A REFERENCE FOR PIN 1 LOCATION ON THE TOP AND BOTTOM OF PACKAGE

PACKAGE DESCRIPTION

S6 Package 6-Lead Plastic TSOT-23 (Reference LTC DWG # 05-08-1636)

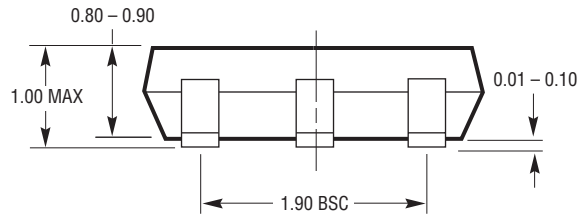
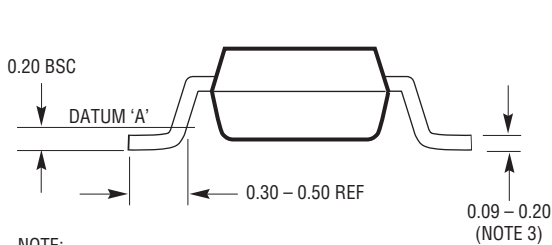
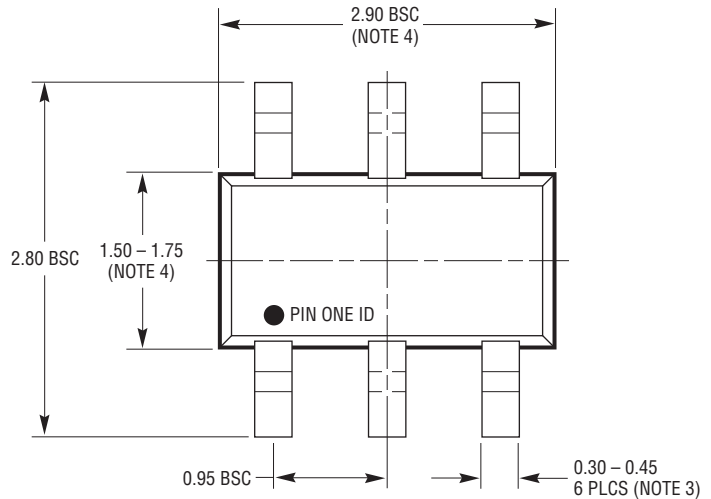
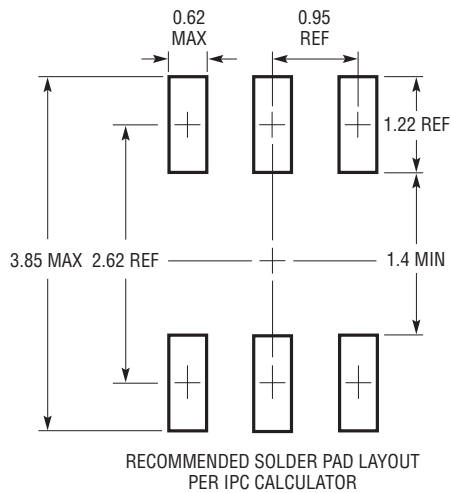

S6 TSOT-23 0302 REV B

- NOTE:
1. DIMENSIONS ARE IN MILLIMETERS
 2. DRAWING NOT TO SCALE
 3. DIMENSIONS ARE INCLUSIVE OF PLATING
 4. DIMENSIONS ARE EXCLUSIVE OF MOLD FLASH AND METAL BURR
 5. MOLD FLASH SHALL NOT EXCEED 0.254mm
 6. JEDEC PACKAGE REFERENCE IS MO-193

TYPICAL APPLICATION

Li-Ion Driver for Six LEDs

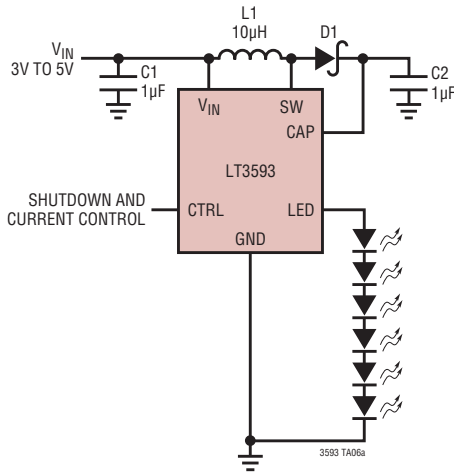

C1: TAIYO YUDEN EMK107BJ105MA
 C2: TAIYO YUDEN GMK316BJ105ML
 L1: MURATA LQH43CN100
 D1: CENTRAL CMDSH05-4

Efficiency

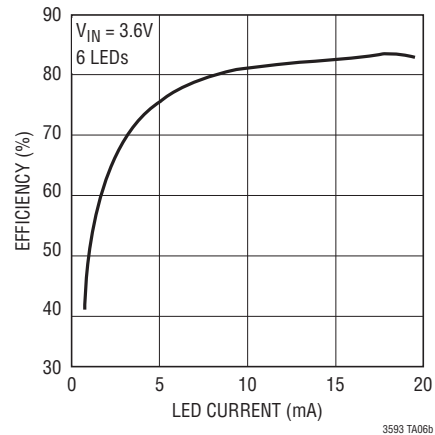

RELATED PARTS

PART NUMBER	DESCRIPTION	COMMENTS
LT1932	Constant Current, 1.2MHz, High Efficiency White LED Boost Regulator	Up to 8 White LEDs, V_{IN} : 1V to 10V, $V_{OUT(MAX)}$ = 34V, I_Q = 1.2mA, I_{SD} < 1µA, ThinSOT™ Package
LT1937	Constant Current, 1.2MHz, High Efficiency White LED Boost Regulator	Up to 4 White LEDs, V_{IN} : 2.5V to 10V, $V_{OUT(MAX)}$ = 34V, I_Q = 1.9mA, I_{SD} < 1µA, ThinSOT and SC70 Packages
LTC®3200	Low Noise, 2MHz Regulated Charge Pump White LED Driver	Up to 6 White LEDs, V_{IN} : 2.7V to 4.5V, I_Q = 8mA, I_{SD} < 1µA, MS Package
LTC3200-5	Low Noise, 2MHz Regulated Charge Pump White LED Driver	Up to 6 White LEDs, V_{IN} : 2.7V to 4.5V, I_Q = 8mA, I_{SD} < 1µA, ThinSOT Package
LTC3201	Low Noise, 1.7MHz Regulated Charge Pump White LED Driver	Up to 6 White LEDs, V_{IN} : 2.7V to 4.5V, I_Q = 6.5mA, I_{SD} < 1µA, MS Package
LTC3202	Low Noise, 1.5MHz Regulated Charge Pump White LED Driver	Up to 8 White LEDs, V_{IN} : 2.7V to 4.5V, I_Q = 5mA, I_{SD} < 1µA, MS Package
LTC3205	High Efficiency, Multidisplay LED Controller	Up to 4 (Main), 2 (Sub) and RGB, V_{IN} : 2.8V to 4.5V, I_Q = 50µA, I_{SD} < 1µA, 24-Lead QFN Package
LTC3210	Low Noise Charge Pump LED Controller	Up to 4 White LEDs and One High current CAM LED, V_{IN} : 2.9V to 4.5V, I_Q = 4.5mA, I_{SD} < 6µA, UD Package
LT3465/LT3465A	Constant Current, 1.2MHz/2.7MHz, High Efficiency White LED Boost Regulator with Integrated Schottky Diode	Up to 6 White LEDs, V_{IN} : 2.7V to 16V, $V_{OUT(MAX)}$ = 34V, I_Q = 1.9mA, I_{SD} < 1µA, ThinSOT Package
LT3466/LT3466-1	Dual Full Function, 2MHz Diodes White LED Step-Up Converter with Built-In Schottkys	Up to 20 White LEDs, V_{IN} : 2.7V to 24V, $V_{OUT(MAX)}$ = 39V, DFN and TSSOP-16 Packages
LT3486	Dual 1.3A White LED Converter with 1000:1 True Color PWM Dimming	Drives Up to 16 100mA White LEDs. V_{IN} : 2.5V to 24V, $V_{OUT(MAX)}$ = 36V, DFN and TSSOP Packages
LT3491	White LED Driver with Integrated Schottky	Up to 6 White LEDs, V_{IN} : 2.5V to 12V, I_Q = 2.6mA, I_{SD} < 10µA, SC70 and 2mm × 2mm DFN Packages
LT3591	White LED Driver with Integrated Schottky	Up to 10 White LEDs, V_{IN} : 2.5V to 12V, I_Q = 4mA, I_{SD} < 11µA, 3mm × 2mm DFN Package

ThinSOT is a trademark of Linear Technology Corporation.