

Precision Zero-Drift Operational Amplifier with Internal Capacitors

FEATURES

- No External Components Required
- Noise Tested and Guaranteed
- Low Aliasing Errors
- Maximum Offset Voltage: 5 μ V
- Maximum Offset Voltage Drift: 0.05 μ V/ $^{\circ}$ C
- Low Noise: 1.6 μ V_{P-P} (0.1Hz to 10Hz)
- Minimum Voltage Gain: 130dB
- Minimum PSRR: 125dB
- Minimum CMRR: 120dB
- Low Supply Current: 1mA
- Single Supply Operation: 4.75V to 16V
- Input Common Mode Range Includes Ground
- Output Swings to Ground
- Typical Overload Recovery Time: 3ms

APPLICATIONS

- Thermocouple Amplifiers
- Electronic Scales
- Medical Instrumentation
- Strain Gauge Amplifiers
- High Resolution Data Acquisition
- DC Accurate RC Active Filters

 LTC and LT are registered trademarks of Linear Technology Corporation.

DESCRIPTION

The LTC[®]1050 is a high performance, low cost zero-drift operational amplifier. The unique achievement of the LTC1050 is that it integrates on-chip the two sample-and-hold capacitors usually required externally by other chopper amplifiers. Further, the LTC1050 offers better combined overall DC and AC performance than is available from other chopper stabilized amplifiers with or without internal sample-and-hold capacitors.

The LTC1050 has an offset voltage of 0.5 μ V, drift of 0.01 μ V/ $^{\circ}$ C, DC to 10Hz, input noise voltage of 1.6 μ V_{P-P} and a typical voltage gain of 160dB. The slew rate of 4V/ μ s and a gain bandwidth product of 2.5MHz are achieved with only 1mA of supply current.

Overload recovery times from positive and negative saturation conditions are 1.5ms and 3ms respectively, which represents an improvement of about 100 times over chopper amplifiers using external capacitors. Pin 5 is an optional external clock input, useful for synchronization purposes.

The LTC1050 is available in standard 8-pin metal can, plastic and ceramic dual-in-line packages as well as an SO-8 package. The LTC1050 can be an improved plug-in replacement for most standard op amps.

TYPICAL APPLICATION

High Performance, Low Cost Instrumentation Amplifier

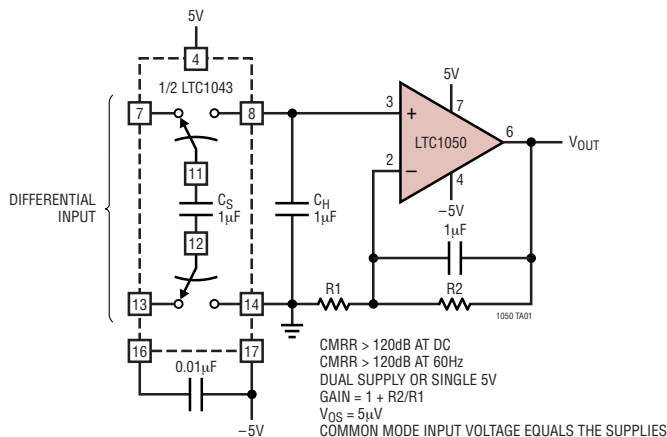

Noise Spectrum

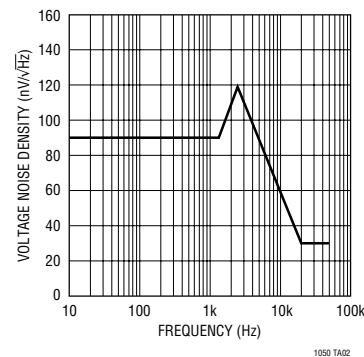

ABSOLUTE MAXIMUM RATINGS (Note 1)

Total Supply Voltage (V^+ to V^-) 18V
 Input Voltage ($V^+ + 0.3V$) to ($V^- - 0.3V$)
 Output Short-Circuit Duration Indefinite
 Storage Temperature Range -65°C to 150°C
 Lead Temperature (Soldering, 10 sec) 300°C

Operating Temperature Range
 LTC1050AC/C -40°C to 85°C
 LTC1050H -40°C to 125°C
 LTC1050AM/M (**OBSOLETE**) -55°C to 125°C

PACKAGE/ORDER INFORMATION

<p>OBSOLETE PACKAGE</p>	<p>ORDER PART NUMBER</p> <p>LTC1050ACH LTC1050CH LTC1050AMH LTC1050MH</p>	<p>OBSOLETE PACKAGE</p>	<p>ORDER PART NUMBER</p> <p>LTC1050CS8 LTC1050HS8</p> <p>S8 PART MARKING</p> <p>1050 1050H</p>
<p>OBSOLETE PACKAGE Consider the N8 Package for Alternate Source</p>	<p>ORDER PART NUMBER</p> <p>LTC1050ACN8 LTC1050CN8</p> <p>LTC1050ACJ8 LTC1050CJ8 LTC1050AMJ8 LTC1050MJ8</p>	<p>OBSOLETE PACKAGE</p>	<p>ORDER PART NUMBER</p> <p>LTC1050CN</p>

Consult LTC Marketing for parts specified with wider operating temperature ranges.

ELECTRICAL CHARACTERISTICS

The ● denotes specifications which apply over the full operating temperature range, otherwise specifications are at $T_A = 25^\circ\text{C}$. $V_S = \pm 5V$

PARAMETER	CONDITIONS	LTC1050AM			LTC1050AC			UNITS
		MIN	TYP	MAX	MIN	TYP	MAX	
Input Offset Voltage	(Note 3)		± 0.5	± 5	± 0.5	± 5		μV
Average Input Offset Drift	(Note 3)		± 0.01	± 0.05	± 0.01	± 0.05		$\mu\text{V}/^\circ\text{C}$
Long Term Offset Voltage Drift			50		50			$\text{nV}/\sqrt{\text{Mo}}$
Input Offset Current	(Note 5)		± 20	± 60 ± 300	± 20	± 60 ± 150		pA pA
Input Bias Current	(Note 5)		± 10	± 30 ± 2000	± 10	± 30 ± 100		pA pA
Input Noise Voltage	0.1Hz to 10Hz (Note 6) DC to 1Hz		1.6 0.6	2.1	1.6 0.6	2.1		$\mu\text{V}_{\text{P-P}}$ $\mu\text{V}_{\text{P-P}}$

1050fb

ELECTRICAL CHARACTERISTICS

The ● denotes specifications which apply over the full operating temperature range, otherwise specifications are at $T_A = 25^\circ\text{C}$. $V_S = \pm 5\text{V}$

PARAMETER	CONDITIONS	LTC1050AM			LTC1050AC			UNITS
		MIN	TYP	MAX	MIN	TYP	MAX	
Input Noise Current	$f = 10\text{Hz}$ (Note 4)		1.8		1.8		$\text{fA}/\sqrt{\text{Hz}}$	
Common Mode Rejection Ratio	$V_{\text{CM}} = V^-$ to 2.7V	●	114 110	140	114 110	140	dB dB	
Power Supply Rejection Ratio	$V_S = \pm 2.375\text{V}$ to $\pm 8\text{V}$	●	125	140	125	140	dB	
Large-Signal Voltage Gain	$R_L = 10\text{k}$, $V_{\text{OUT}} = \pm 4\text{V}$	●	130	160	130	160	dB	
Maximum Output Voltage Swing	$R_L = 10\text{k}$ $R_L = 100\text{k}$	●	± 4.7	± 4.85 ± 4.95	± 4.7	± 4.85 ± 4.95	V V	
Slew Rate	$R_L = 10\text{k}$, $C_L = 50\text{pF}$		4		4		$\text{V}/\mu\text{s}$	
Gain Bandwidth Product			2.5		2.5		MHz	
Supply Current	No Load	●	1	1.5 2.3	1	1.5 2.3	mA mA	
Internal Sampling Frequency			2.5		2.5		kHz	

The ● denotes specifications which apply over the full operating temperature range, otherwise specifications are at $T_A = 25^\circ\text{C}$. $V_S = \pm 5\text{V}$

PARAMETER	CONDITIONS	LTC1050M/H			LTC1050C			UNITS
		MIN	TYP	MAX	MIN	TYP	MAX	
Input Offset Voltage	(Note 3)		± 0.5	± 5	± 0.5	± 5	μV	
Average Input Offset Drift	(Note 3)	●	± 0.01	± 0.05	± 0.01	± 0.05	$\mu\text{V}/^\circ\text{C}$	
Long Term Offset Voltage Drift			50		50		$\text{nV}/\sqrt{\text{Mo}}$	
Input Offset Current	(Note 5)	●	± 20	± 100 ± 300	± 20	± 125 ± 200	μA μA	
Input Bias Current	(Note 5)	●	± 10	± 50 ± 2000	± 10	± 75 ± 150	μA μA	
Input Noise Voltage	$R_S = 100\Omega$, 0.1Hz to 10Hz (Note 6) $R_S = 100\Omega$, DC to 1Hz		1.6 0.6		1.6 0.6		$\mu\text{V}_{\text{P-P}}$ $\mu\text{V}_{\text{P-P}}$	
Input Noise Current	$f = 10\text{Hz}$ (Note 4)		1.8		1.8		$\text{fA}/\sqrt{\text{Hz}}$	
Common Mode Rejection Ratio	$V_{\text{CM}} = V^-$ to 2.7V LTC1050M/C LTC1050H	● ●	114 110 100	130	114 110	130	dB dB dB	
Power Supply Rejection Ratio	$V_S = \pm 2.375\text{V}$ to $\pm 8\text{V}$, LTC1050M/C LTC1050H	● ●	120 110	140	120	140	dB dB	
Large-Signal Voltage Gain	$R_L = 10\text{k}$, $V_{\text{OUT}} = \pm 4\text{V}$	●	120	160	120	160	dB	
Maximum Output Voltage Swing	$R_L = 10\text{k}$ $R_L = 100\text{k}$	●	± 4.7	± 4.85 ± 4.95	± 4.7	± 4.85 ± 4.95	V V	
Slew Rate	$R_L = 10\text{k}$, $C_L = 50\text{pF}$		4		4		$\text{V}/\mu\text{s}$	
Gain Bandwidth Product			2.5		2.5		MHz	
Supply Current	No Load	●	1	1.5 2.3	1	1.5 2.3	mA mA	
Internal Sampling Frequency			2.5		2.5		kHz	

Note 1: Absolute Maximum Ratings are those values beyond which the life of the device may be impaired.

Note 2: Connecting any terminal to voltages greater than V^+ or less than V^- may cause destructive latchup. It is recommended that no sources operating from external supplies be applied prior to power-up of the LTC1050.

Note 3: These parameters are guaranteed by design. Thermocouple effects preclude measurement of these voltage levels in high speed automatic test systems. V_{OS} is measured to a limit determined by test equipment capability.

Note 4: Current Noise is calculated from the formula: $I_n = \sqrt{(2q \cdot I_b)}$ where $q = 1.6 \cdot 10^{-19}$ Coulomb.

Note 5: At $T_A \leq 0^\circ\text{C}$ these parameters are guaranteed by design and not tested.

Note 6: Every lot of LTC1050AM and LTC1050AC is 100% tested for Broadband Noise at 1kHz and sample tested for Input Noise Voltage at 0.1Hz to 10Hz .

TYPICAL PERFORMANCE CHARACTERISTICS

Offset Voltage vs Sampling Frequency

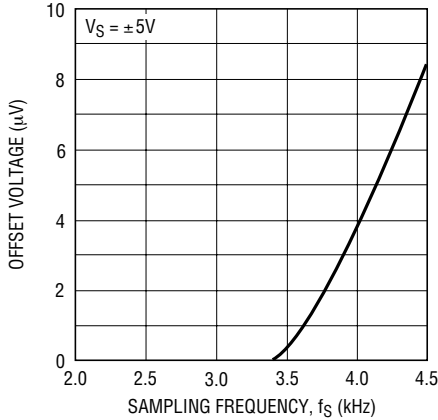

1050 G01

10Hz_{p-p} Noise vs Sampling Frequency

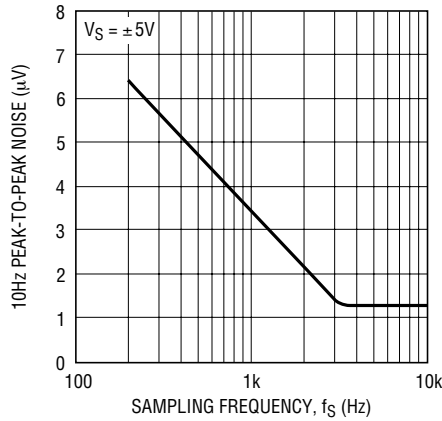

1050 G02

Common Mode Input Range vs Supply Voltage

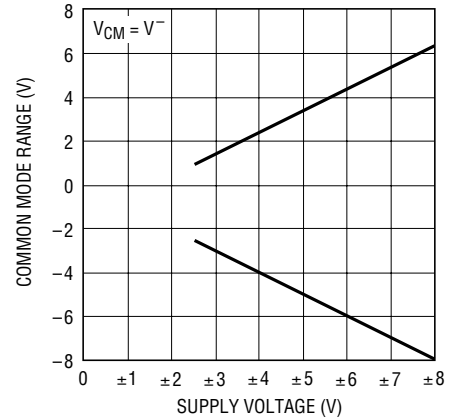

1050 G03

Sampling Frequency vs Supply Voltage

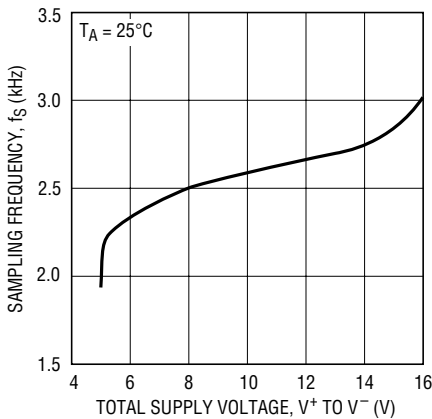

1050 G04

Sampling Frequency vs Temperature

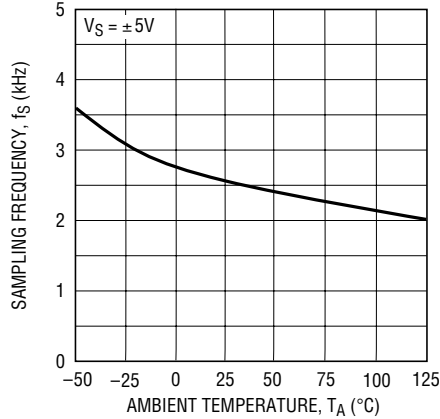

1050 G05

Overload Recovery

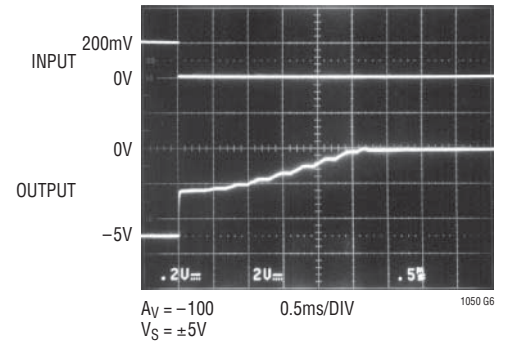

1050 G6

Supply Current vs Supply Voltage

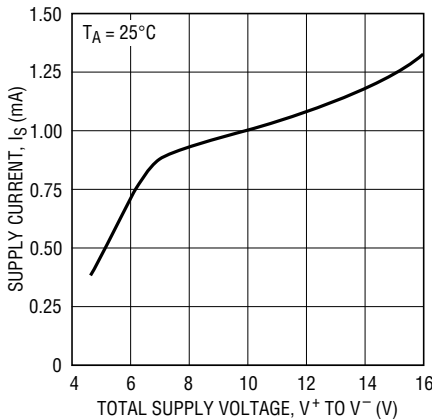

1050 G07

Supply Current vs Temperature

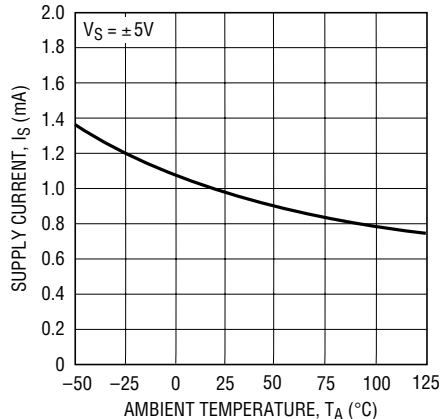

1050 G08

Short-Circuit Output Current vs Supply Voltage

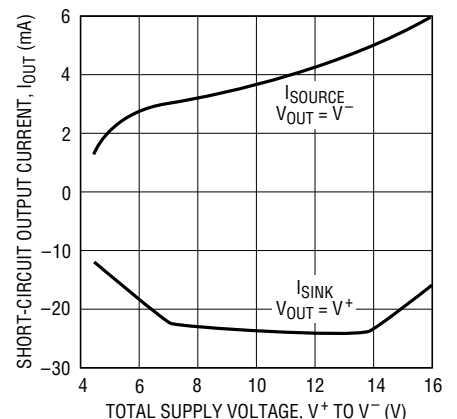

1050 G09

1050fb

TYPICAL PERFORMANCE CHARACTERISTICS

Gain/Phase vs Frequency

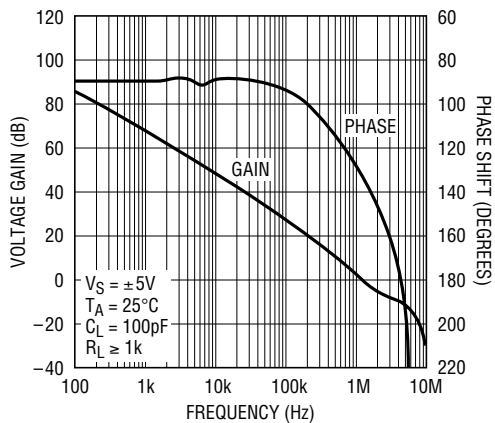

Small-Signal Transient Response

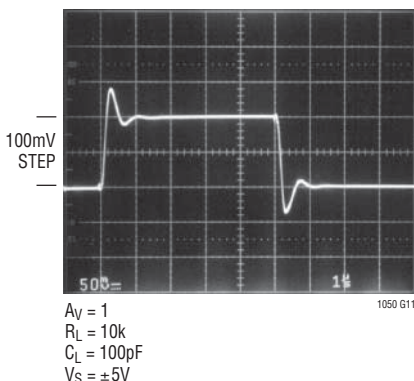

Large-Signal Transient Response

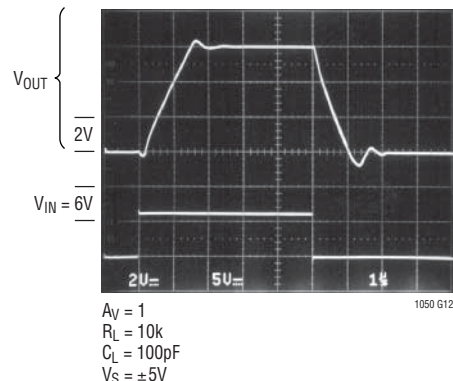

LTC1050 DC to 1Hz Noise

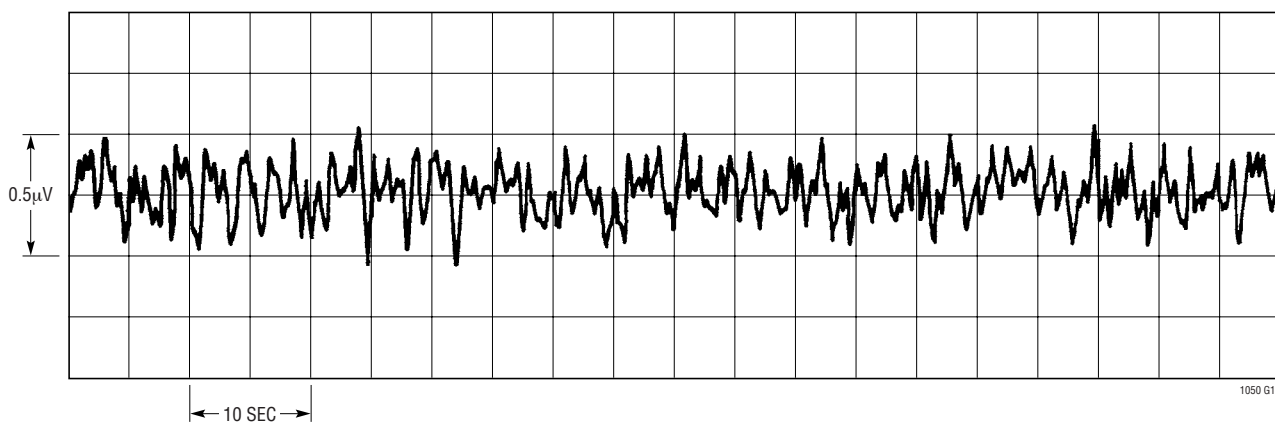

LTC1050 DC to 10Hz Noise

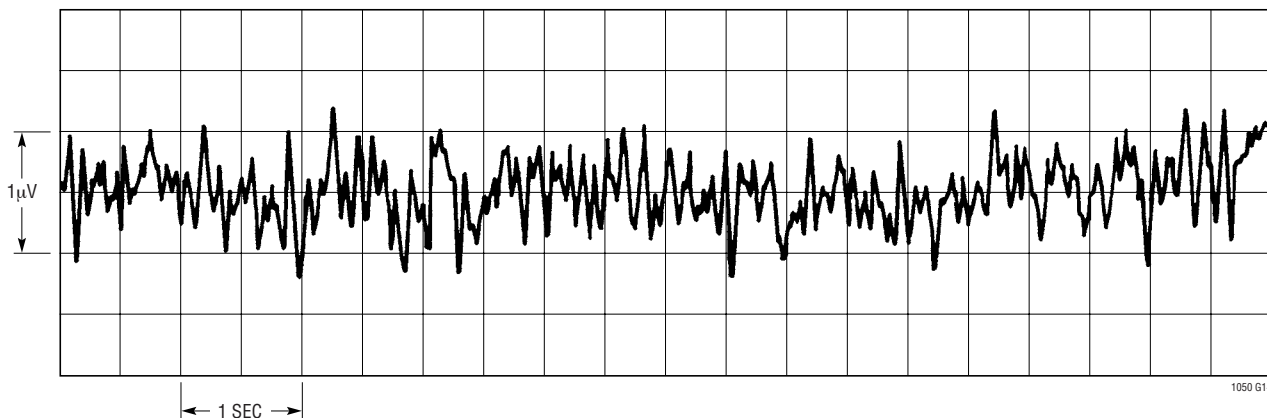

TEST CIRCUITS

Electrical Characteristics Test Circuit

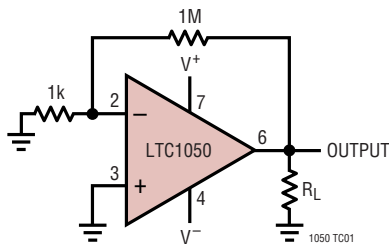

DC-10Hz Noise Test Circuit

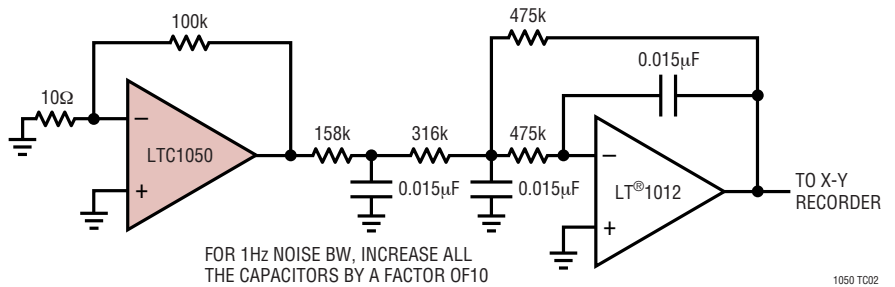

APPLICATIONS INFORMATION

ACHIEVING PICOAMPERE/MICROVOLT PERFORMANCE

Picoamperes

In order to realize the picoampere level of accuracy of the LTC1050, proper care must be exercised. Leakage currents in circuitry external to the amplifier can significantly degrade performance. High quality insulation should be used (e.g., Teflon, Kel-F); cleaning of all insulating surfaces to remove fluxes and other residues will probably be necessary—particularly for high temperature performance. Surface coating may be necessary to provide a moisture barrier in high humidity environments.

Board leakage can be minimized by encircling the input connections with a guard ring operated at a potential close to that of the inputs: in inverting configurations the guard ring should be tied to ground; in noninverting connections to the inverting input (see Figure 1). Guarding both sides of the printed circuit board is required. Bulk leakage reduction depends on the guard ring width.

Microvolts

Thermocouple effect must be considered if the LTC1050's ultralow drift is to be fully utilized. Any connection of dissimilar metals forms a thermoelectric junction producing an electric potential which varies with temperature (Seebeck effect). As temperature sensors, thermocouples exploit this phenomenon to produce useful information. In low drift amplifier circuits the effect is a primary source of error.

Connectors, switches, relay contacts, sockets, resistors, solder and even copper wire are all candidates for thermal

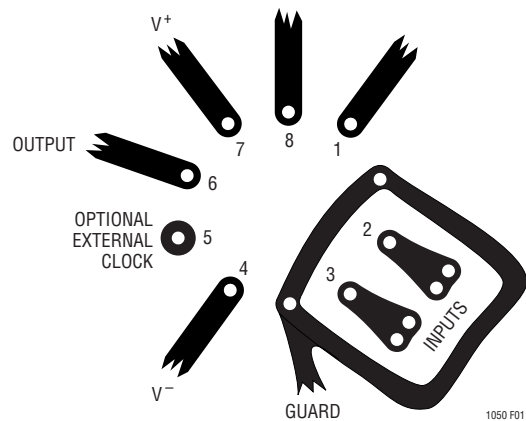

Figure 1

EMF generation. Junctions of copper wire from different manufacturers can generate thermal EMFs of 200nV/°C—4 times the maximum drift specification of the LTC1050. The copper/kovar junction, formed when wire or printed circuit traces contact a package lead, has a thermal EMF of approximately 35μV/°C—700 times the maximum drift specification of the LTC1050.

Minimizing thermal EMF-induced errors is possible if judicious attention is given to circuit board layout and component selection. It is good practice to minimize the number of junctions in the amplifier's input signal path. Avoid connectors, sockets, switches and relays where possible. In instances where this is not possible, attempt to balance the number and type of junctions so that differential cancellation occurs. Doing this may involve deliberately introducing junctions to offset unavoidable junctions.

APPLICATIONS INFORMATION

Figure 2 is an example of the introduction of an unnecessary resistor to promote differential thermal balance. Maintaining compensating junctions in close physical proximity will keep them at the same temperature and reduce thermal EMF errors.

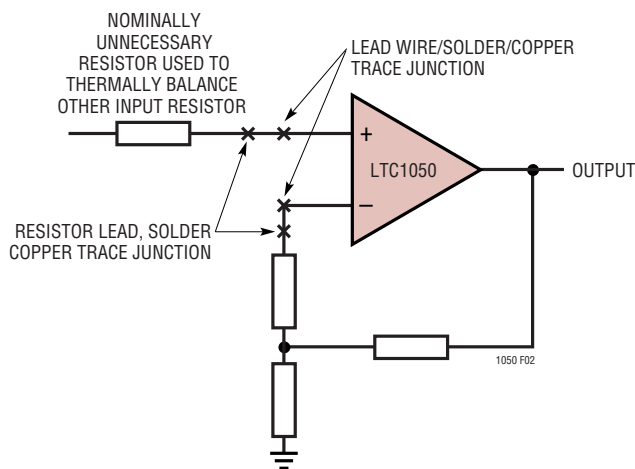

Figure 2

When connectors, switches, relays and/or sockets are necessary they should be selected for low thermal EMF activity. The same techniques of thermally balancing and coupling the matching junctions are effective in reducing the thermal EMF errors of these components.

Resistors are another source of thermal EMF errors. Table 1 shows the thermal EMF generated for different resistors. The temperature gradient across the resistor is important, not the ambient temperature. There are two junctions formed at each end of the resistor and if these junctions are at the same temperature, their thermal EMFs will cancel each other. The thermal EMF numbers are approximate and vary with resistor value. High values give higher thermal EMF.

Table 1. Resistor Thermal EMF

RESISTOR TYPE	THERMAL EMF/°C GRADIENT
Tin Oxide	~mV/°C
Carbon Composition	~450 μ V/°C
Metal Film	~20 μ V/°C
Wire Wound	
Evenohm	~2 μ V/°C
Manganin	~2 μ V/°C

PACKAGE-INDUCED OFFSET VOLTAGE

Package-induced thermal EMF effects are another important source of errors. It arises at the copper/kovar junctions formed when wire or printed circuit traces contact a package lead. Like all the previously mentioned thermal EMF effects, it is outside the LTC1050's offset nulling loop and cannot be cancelled. The input offset voltage specification of the LTC1050 is actually set by the package-induced warm-up drift rather than by the circuit itself. The thermal time constant ranges from 0.5 to 3 minutes, depending upon package type.

OPTIONAL EXTERNAL CLOCK

An external clock is not required for the LTC1050 to operate. The internal clock circuit of the LTC1050 sets the nominal sampling frequency at around 2.5kHz. This frequency is chosen such that it is high enough to remove the amplifier 1/f noise, yet still low enough to allow internal circuits to settle. The oscillator of the internal clock circuit has a frequency 4 times the sampling frequency and its output is brought out to Pin 5 through a 2k resistor. When the LTC1050 operates without using an external clock, Pin 5 should be left floating and capacitive loading on this pin should be avoided. If the oscillator signal on Pin 5 is used to drive other external circuits, a buffer with low input capacitance is required to minimize loading on this pin. Figure 3 illustrates the internal sampling frequency versus capacitive loading at Pin 5.

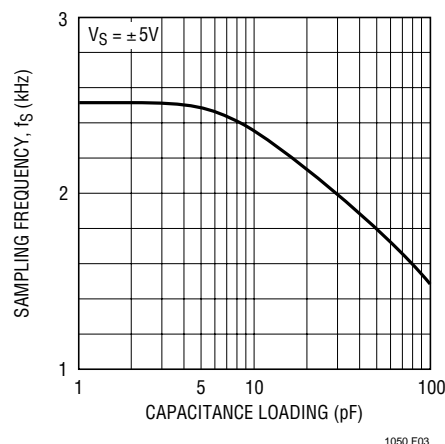

Figure 3. Sampling Frequency vs Capacitance Loading at Pin 5

APPLICATIONS INFORMATION

When an external clock is used, it is directly applied to Pin 5. The internal oscillator signal on Pin 5 has very low drive capability and can be overdriven by any external signal. When the LTC1050 operates on $\pm 5V$ power supplies, the external clock level is TTL compatible.

Using an external clock can affect performance of the LTC1050. Effects of external clock frequency on input offset voltage and input noise voltage are shown in the Typical Performance Characteristics section. The sampling frequency is the external clock frequency divided by 4. Input bias currents at temperatures below $100^{\circ}C$ are dominated by the charge injection of input switches and they are basically proportional to the sampling frequency. At higher temperatures, input bias currents are mainly due to leakage currents of the input protection devices and are insensitive to the sampling frequency.

LOW SUPPLY OPERATION

The minimum supply for proper operation of the LTC1050 is typically below $4V (\pm 2V)$. In single supply applications,

PSRR is guaranteed down to $4.7V (\pm 2.35V)$ to ensure proper operation down to the minimum TTL specified voltage of $4.75V$.

PIN COMPATIBILITY

The LTC1050 is pin compatible with the 8-pin versions of 7650, 7652 and other chopper-stabilized amplifiers. The 7650 and 7652 require the use of two external capacitors connected to Pin 1 and Pin 8 that are not needed for the LTC1050. Pin 1 and Pin 8 of the LTC1050 are not connected internally while Pin 5 is an optional external clock input pin. The LTC1050 can be a direct plug-in for the 7650 and 7652 even if the two capacitors are left on the circuit board.

In applications operating from below $16V$ total power supply, ($\pm 8V$), the LTC1050 can replace many industry standard operational amplifiers such as the 741, LM101, LM108, OP07, etc. For devices like the 741 and LM101, the removal of any connection to Pin 5 is all that is needed.

TYPICAL APPLICATIONS

Strain Gauge Signal Conditioner with Bridge Excitation

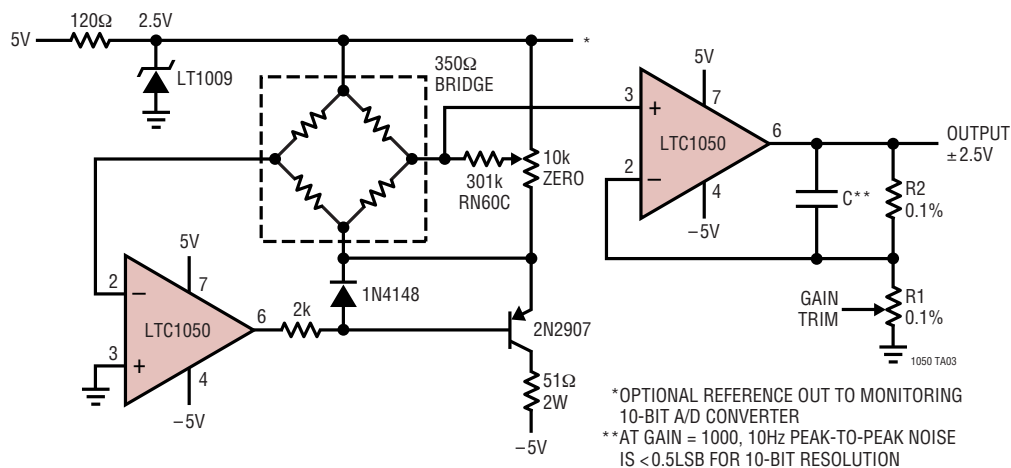

TYPICAL APPLICATIONS

Single Supply Thermocouple Amplifier

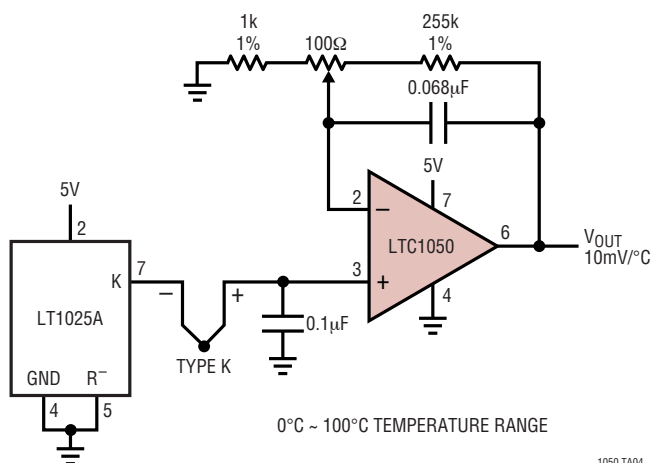

Air Flow Detector

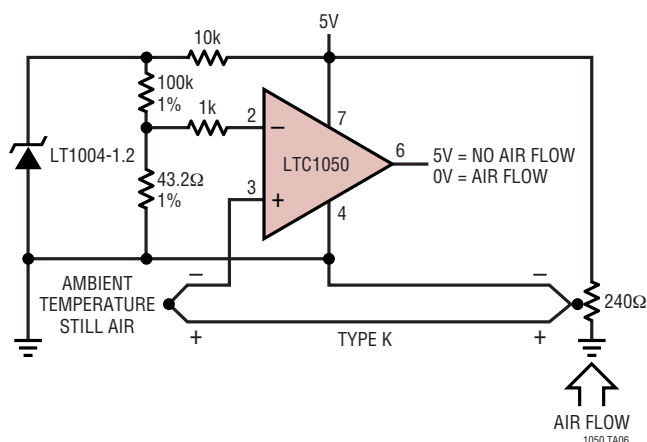

Battery-Operated Temperature Monitor with 10-Bit Serial Output A/D

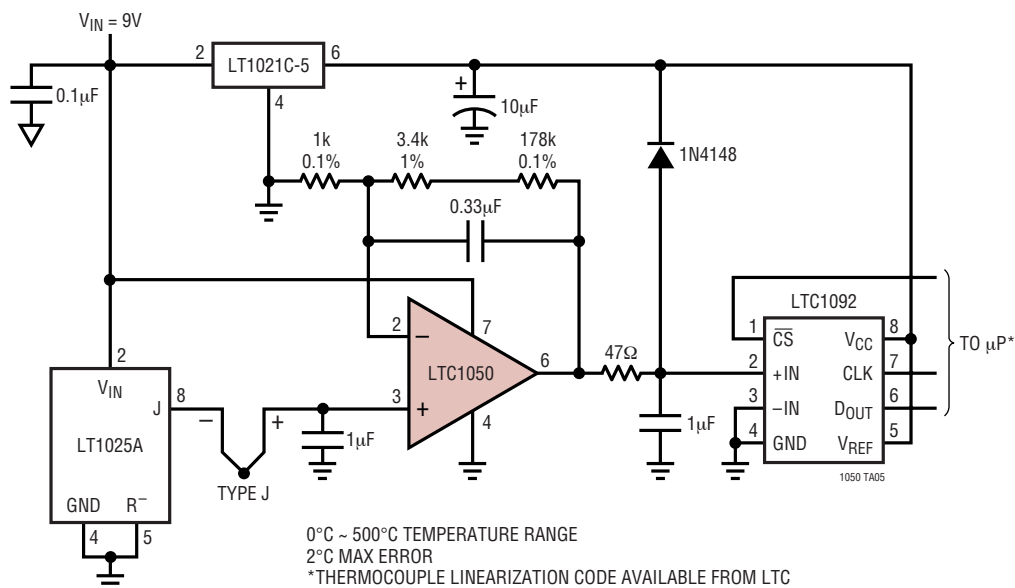

TYPICAL APPLICATIONS

Fast Precision Inverter

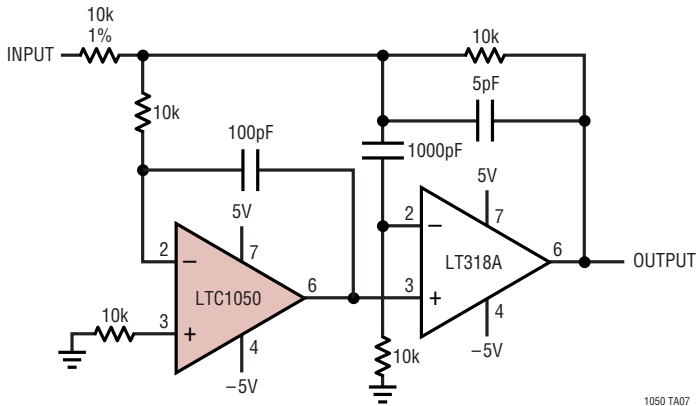

FULL POWER BANDWIDTH = 2MHz
 SLEW RATE $\geq 40V/\mu s$
 SETTLE TIME = 5 μs TO 0.01% (10V STEP)
 OFFSET VOLTAGE = 5 μV
 OFFSET DRIFT = 50nV/ $^{\circ}C$

1050 TA07

$\pm 100mA$ Output Drive

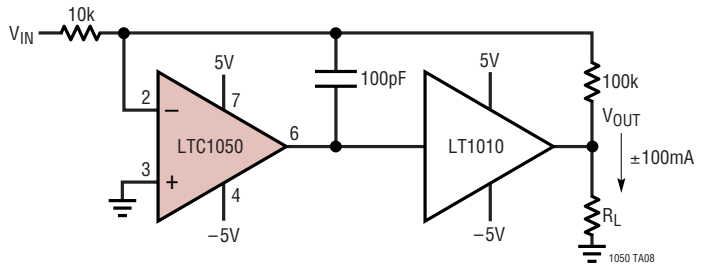

FULL POWER BANDWIDTH = 10kHz
 $V_{OS} = 5\mu V$
 $V_{OS}/\Delta T = 50nV/^{\circ}C$
 GAIN = 10

1050 TA08

Ground Referred Precision Current Sources

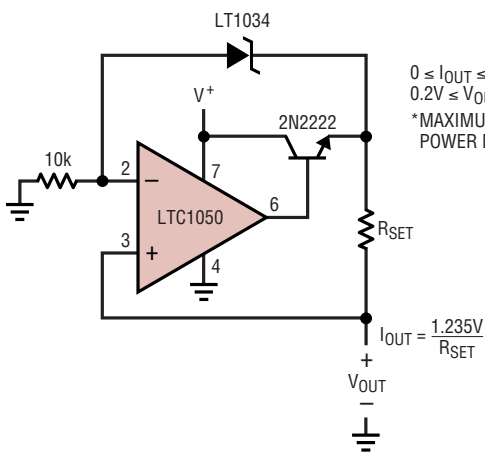

$0 \leq I_{OUT} \leq 25mA^*$
 $0.2V \leq V_{OUT} \leq (V^+) - 2V$
 *MAXIMUM CURRENT LIMITED BY
 POWER DISSIPATION OF 2N2222

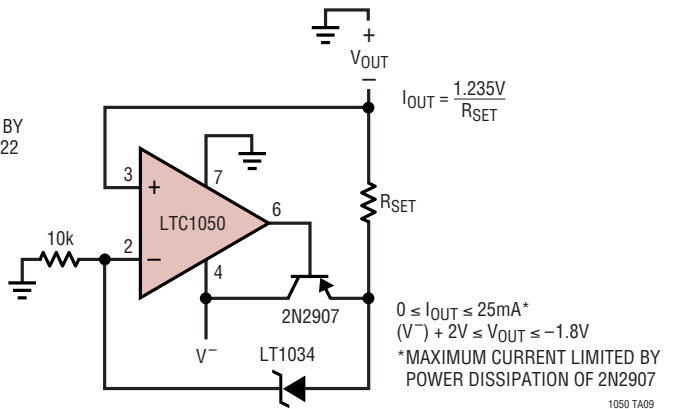

$0 \leq I_{OUT} \leq 25mA^*$
 $(V^-) + 2V \leq V_{OUT} \leq -1.8V$
 *MAXIMUM CURRENT LIMITED BY
 POWER DISSIPATION OF 2N2907

1050 TA09

TYPICAL APPLICATIONS

Precision Voltage Controlled Current Source with Ground Referred Input and Output

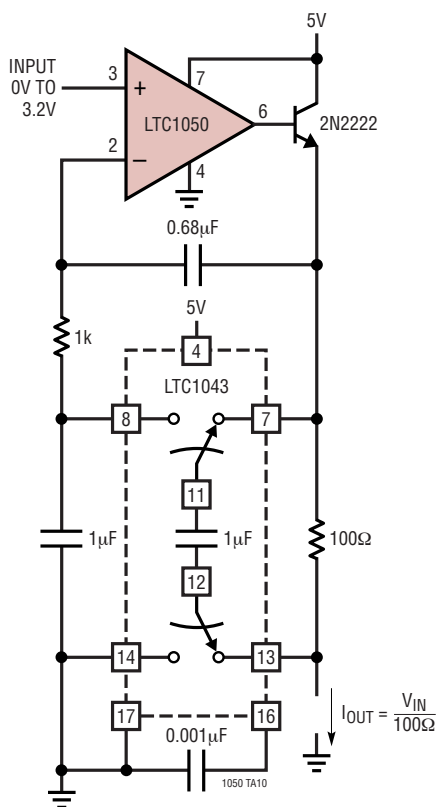

Sample-and-Hold Amplifier

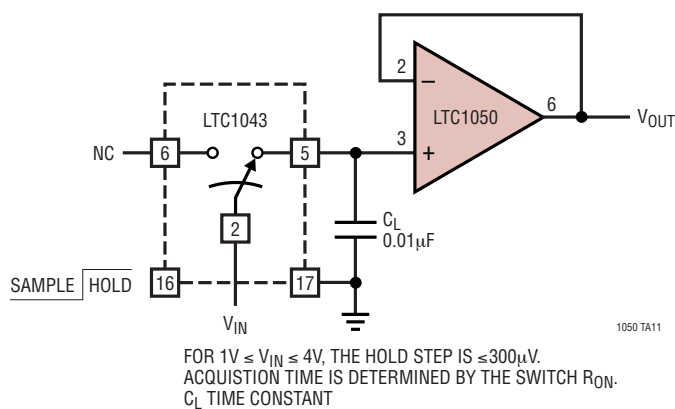

Ultraprecision Voltage Inverter

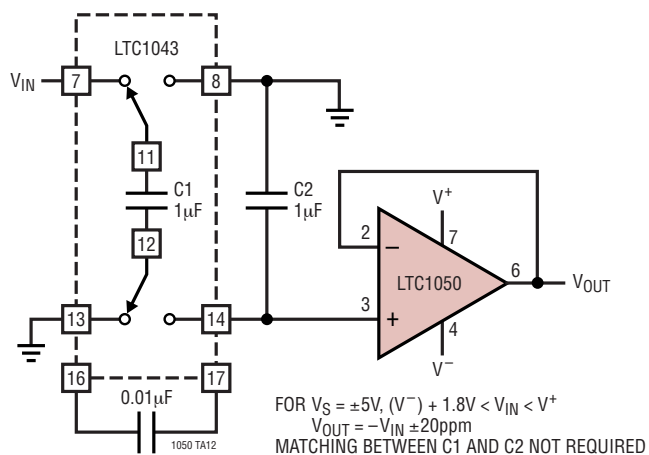

TYPICAL APPLICATIONS

Instrumentation Amplifier with Low Offset and Input Bias Current

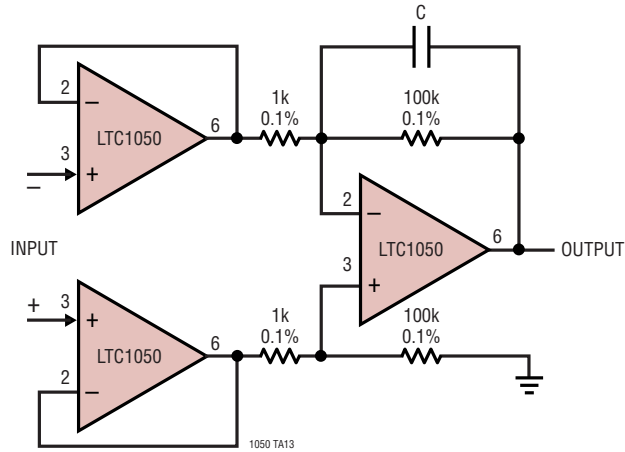

OFFSET VOLTAGE $\leq \pm 10\mu\text{V}$
 INPUT BIAS CURRENT = 15pA
 CMRR = 100dB FOR GAIN = 100
 INPUT REFERRED NOISE = $5\mu\text{V}_{\text{p-p}}$ FOR C = 0.1 μF
 = $20\mu\text{V}_{\text{p-p}}$ FOR C = 0.01 μF

Instrumentation Amplifier with 100V Common Mode Input Voltage

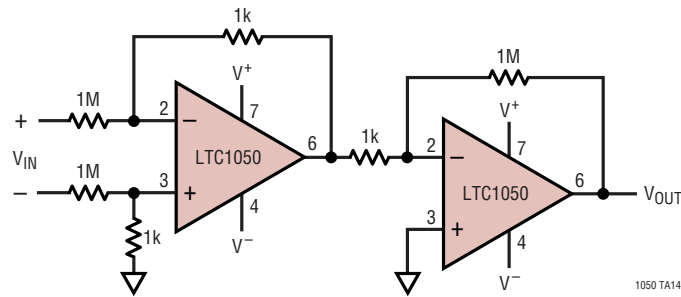

OUTPUT OFFSET $\leq 5\text{mV}$
 FOR 0.1% RESISTORS, CMRR = 54dB

Single Supply Instrumentation Amplifier

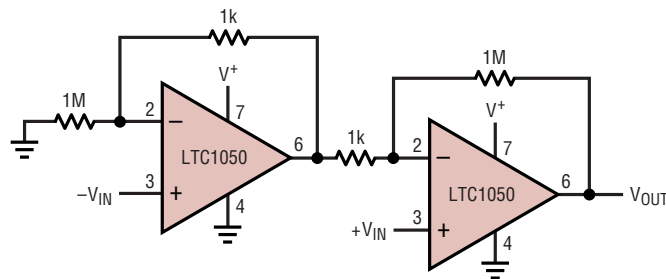

OUTPUT OFFSET $\leq 5\text{mV}$
 FOR 0.1% RESISTORS, CMRR = 54dB

TYPICAL APPLICATIONS

Photodiode Amplifier

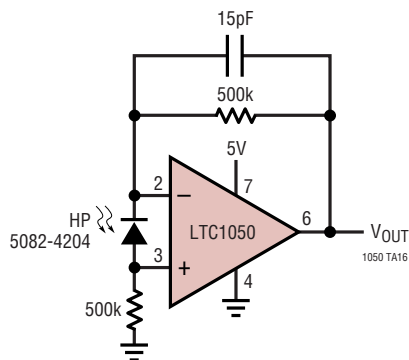

6 Decade Log Amplifier

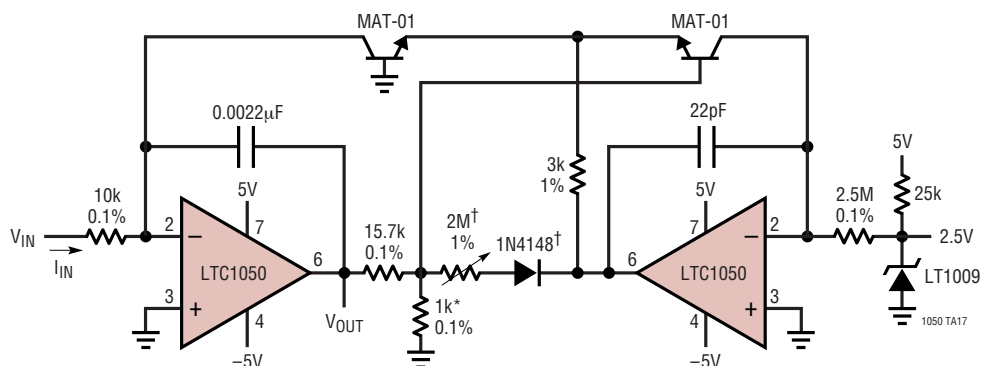

ERROR REFERRED TO INPUT <1%
FOR INPUT CURRENT RANGE 1nA - 1mA
*TEL LAB TYPE Q81
†CORRECTS FOR NONLINEARITIES

$$V_{OUT} = -\text{LOG} \left(\frac{I_{IN}}{1\mu\text{A}} \right) = -\text{LOG} \left(\frac{V_{IN}}{10\text{mV}} \right) = -\text{LOG}(V_{IN}) - 2\text{V}$$

DC Accurate, 10Hz, 7th Order Lowpass Bessel Filter

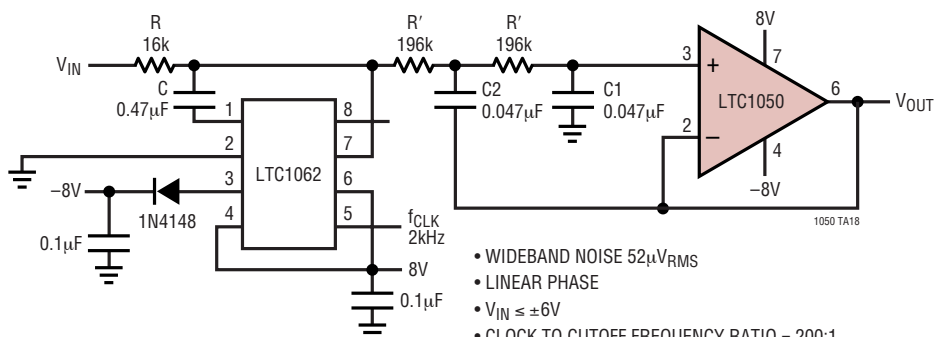

- WIDEBAND NOISE 52µVRMS
- LINEAR PHASE
- $V_{IN} \leq \pm 6\text{V}$
- CLOCK TO CUTOFF FREQUENCY RATIO = 200:1

PACKAGE DESCRIPTION

H Package
8-Lead TO-5 Metal Can (.200 Inch PCD)
 (Reference LTC DWG # 05-08-1320)

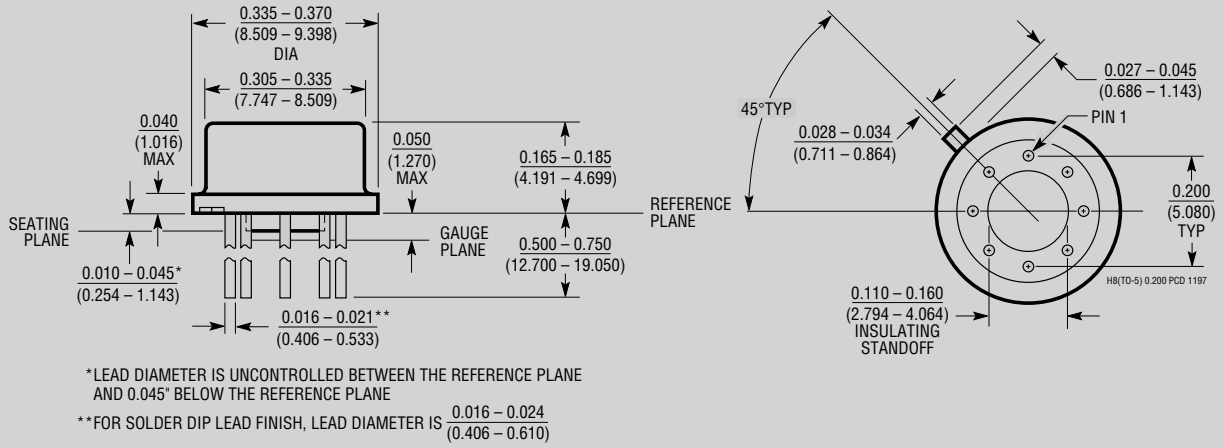

J8 Package
8-Lead CERDIP (Narrow .300 Inch, Hermetic)
 (Reference LTC DWG # 05-08-1110)

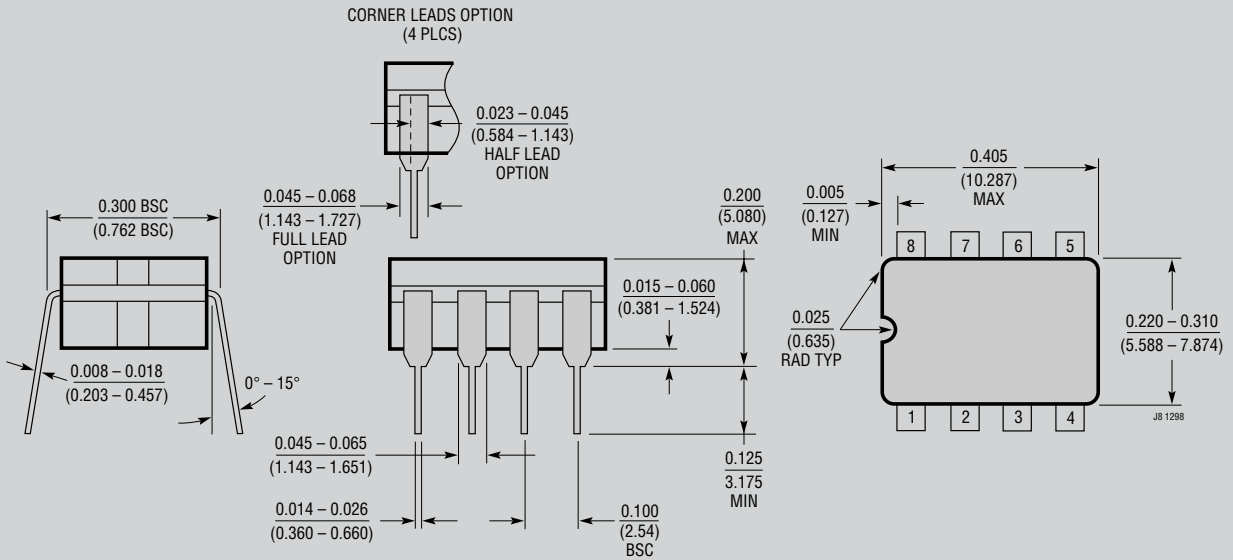

OBSOLETE PACKAGES

PACKAGE DESCRIPTION

N8 Package 8-Lead PDIP (Narrow .300 Inch) (Reference LTC DWG # 05-08-1510)

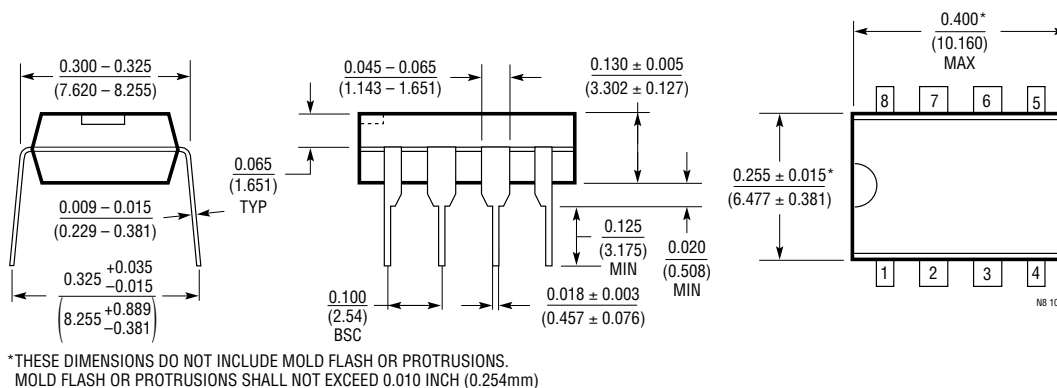

N Package 14-Lead PDIP (Narrow .300 Inch) (Reference LTC DWG # 05-08-1510)

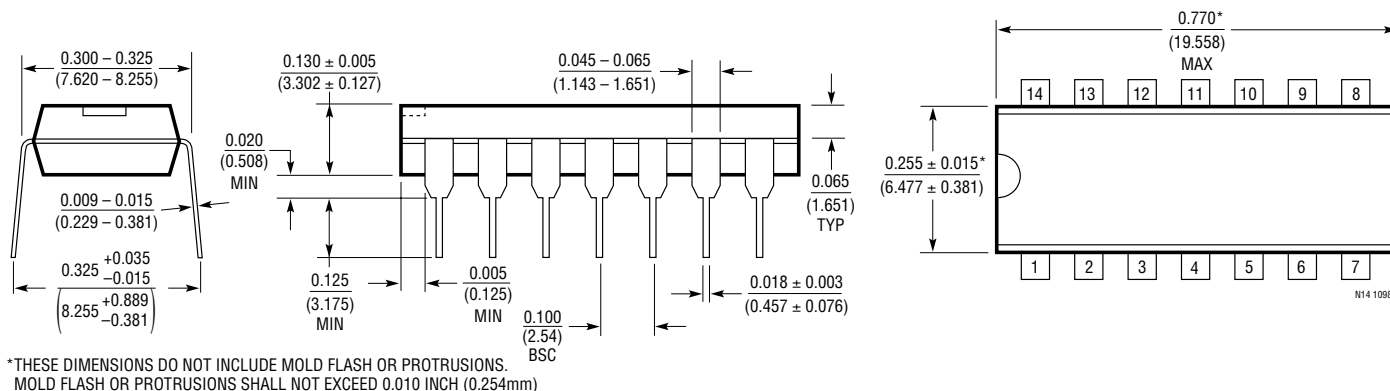

S8 Package 8-Lead Plastic Small Outline (Narrow .150 Inch) (Reference LTC DWG # 05-08-1610)

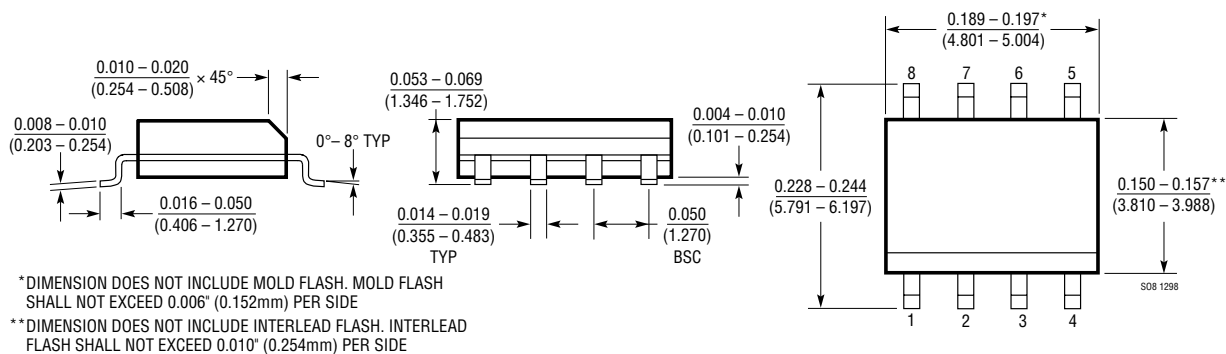

TYPICAL APPLICATIONS

DC Accurate 10th Order Max Flat Lowpass Filter

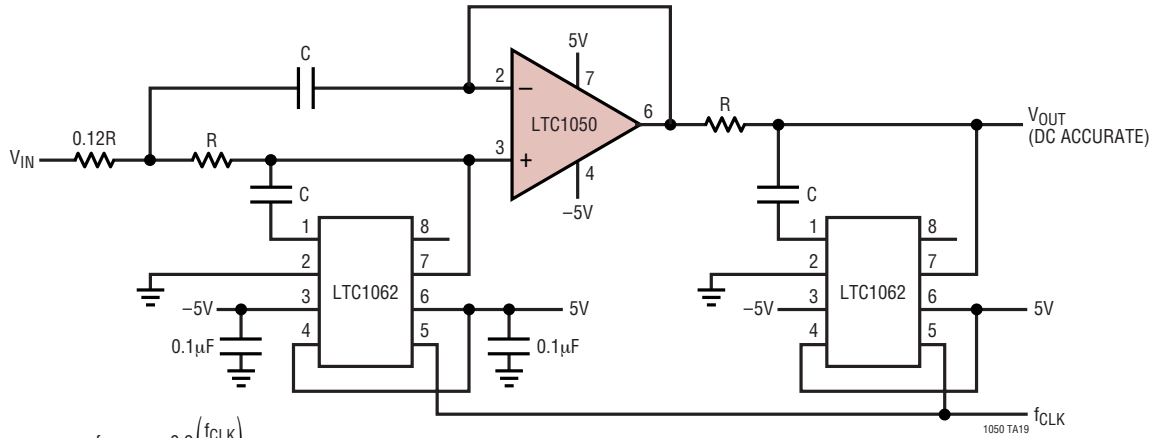

- $f_{CUTOFF} = 0.9 \left(\frac{f_{CLK}}{100} \right)$
- $RC = \frac{0.2244}{f_{CUTOFF}}$
- 60dB/OCT. SLOPE
- PASSBAND ERROR < 0.1dB FOR $0 \leq f \leq 0.67f_{CUTOFF}$
- THD = 0.04%, WIDEBAND NOISE = $120\mu V_{RMS}$
- $f_{CLK} \approx 100kHz$

DC Accurate, Noninverting 2nd Order Lowpass Filter

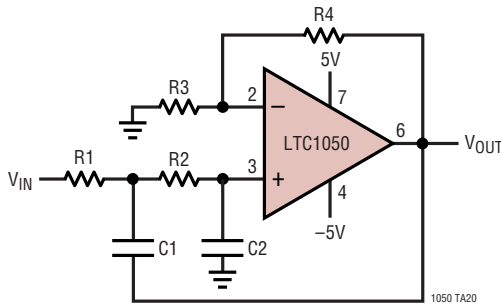

Gain of 1, 10Hz 3rd Order Bessel DC Accurate Lowpass Filter

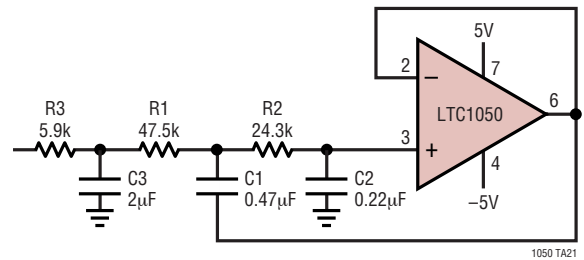

Q = 0.707, $f_C = 20Hz$. FOR $f_C = 10Hz$, THE RESISTOR (R1, R2) VALUES SHOULD BE DOUBLED

COMPONENT VALUES

DC GAIN	R3	R4	R1	R2	C1	C2
1	∞	0	32.4k	18.7k	0.47 μF	0.22 μF
2	10k	10k	11.8k	24.3k	0.47 μF	0.47 μF
4	10.5k	31.6k	18.7k	34.8k	0.22 μF	0.47 μF
6	10.2k	51.1k	14k	46.4k	0.22 μF	0.47 μF
8	10.2k	71.5k	11.8k	54.9k	0.22 μF	0.47 μF
10	10.1k	90.9k	10.5k	61.9k	0.22 μF	0.47 μF

RELATED PARTS

PART NUMBER	DESCRIPTION	COMMENTS
LTC1051	Dual Zero-Drift Op Amp's	Dual Version of the LTC1050
LTC2050	Zero-Drift Op Amp	SOT-23 Package
LTC2051	Zero-Drift Op Amp's	Dual Version of the LTC2050 in an MS8 Package
LTC2053	Zero-Drift Instrumentation Amp	110dB CMRR, MS8 Package, Gain Programmable