

FEATURES

- **Ultralow Quiescent Current: 2.1 μ A Typ (LTC1440)**
- **Reference Output Drives 0.01 μ F Capacitor**
- **Adjustable Hysteresis (LTC1440/LTC1442)**
- **Wide Supply Range:**
 Single: 2V to 11V
 Dual: \pm 1V to \pm 5.5V
- **Input Voltage Range Includes the Negative Supply**
- **TTL/CMOS Compatible Outputs**
- **12 μ s Propagation Delay with 10mV Overdrive**
- **No Crowbar Current**
- **40mA Continuous Source Current**
- **Pin Compatible Upgrades for MAX921/922/923**
- **3mm x 3mm x 0.75mm DFN Package (LTC1440)**

APPLICATIONS

- Battery-Powered System Monitoring
- Threshold Detectors
- Window Comparators
- Oscillator Circuits

LT, LT, LTC and LTM are registered trademarks of Linear Technology Corporation. All other trademarks are the property of their respective owners.

DESCRIPTION

The LTC[®]1440/LTC1441/LTC1442 are ultralow power single and dual comparators with built-in references. The comparators feature less than 3.7 μ A supply current over temperature (LTC1440), a 1.182V \pm 1% reference, programmable hysteresis (LTC1440/LTC1442) and TTL/CMOS outputs that sink and source current. The reference output can drive a bypass capacitor of up to 0.01 μ F without oscillation.

The comparators operate from a single 2V to 11V supply or a dual \pm 1V to \pm 5.5V supply (LTC1440). Comparator hysteresis is easily programmed by using two resistors and the HYST pin (LTC1440/LTC1442). Each comparator's input operates from the negative supply to within 1.3V of the positive supply. The comparator output stage can continuously source up to 40mA. By eliminating the cross-conducting current that normally happens when the comparator changes logic states, the power supply glitches are eliminated.

The LTC1440 is available in 8-pin PDIP, SO, MSOP and DFN packages. The LTC1441/LTC1442 are available in 8-pin PDIP and SO packages.

TYPICAL APPLICATION

Micropower 2.9V V_{CC} Threshold Detector

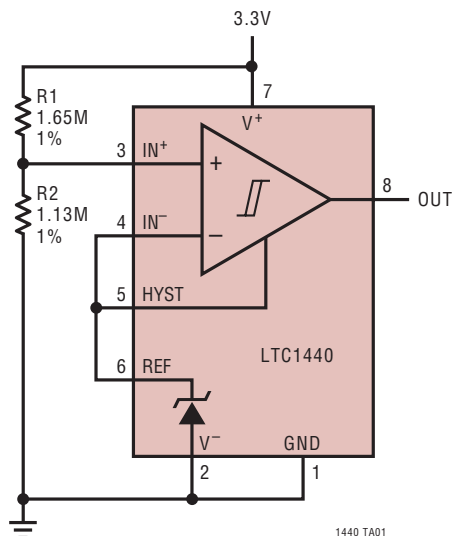

LTC1440 Supply Current vs Temperature

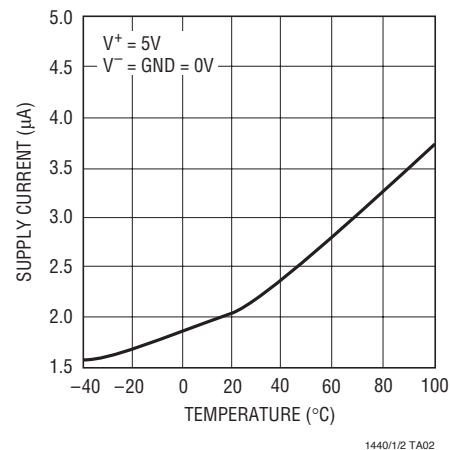

1440/1/2 TA02

144012fd

LTC 1440/LTC 1441/LTC 1442

ABSOLUTE MAXIMUM RATINGS

(Note 1)

Voltage

V⁺ to V⁻, V⁺ to GND, GND to V⁻ 12V to -0.3V
 IN⁺, IN⁻, HYST (V⁺ + 0.3V) to (V⁻ - 0.3V)
 REF (V⁺ + 0.3V) to (V⁻ - 0.3V)
 OUT (LTC1440) (V⁺ + 0.3V) to (GND - 0.3V)
 OUT (LTC1441/LTC1442) ... (V⁺ + 0.3V) to (V⁻ - 0.3V)

Current

IN⁺, IN⁻, HYST 20mA
 REF 20mA
 OUT 50mA

OUT Short-Circuit Duration (V⁺ ≤ 5.5V) Continuous
 Power Dissipation 500mW
 Operating Temperature Range
 LTC144XC 0°C to 70°C
 LTC144XI -40°C to 85°C
 Storage Temperature Range -65°C to 150°C
 Storage Temperature Range
 (DD Package) -65°C to 125°C
 Junction Temperature 150°C
 Junction Temperature (DD Package) 125°C
 Lead Temperature (Soldering, 10 sec) 300°C

PACKAGE/ORDER INFORMATION

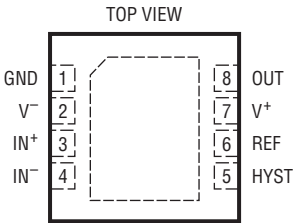
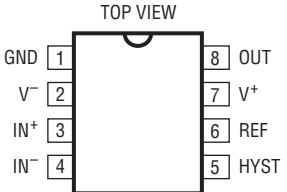
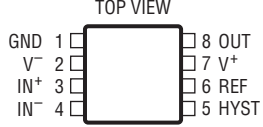
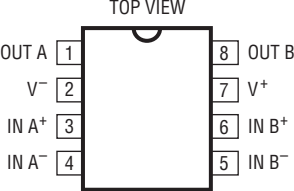
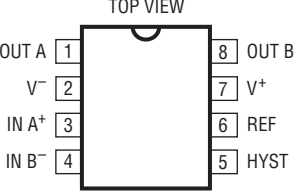
 <p>DD PACKAGE 8-LEAD (3mm × 3mm) PLASTIC DFN</p> <p>T_{JMAX} = 125°C, θ_{JA} = 160°C/W (DD) UNDERSIDE METAL CONNECTED TO V⁻ (PCB CONNECTION OPTIONAL)</p>		 <p>N8 PACKAGE 8-LEAD PDIP S8 PACKAGE 8-LEAD PLASTIC SO</p> <p>T_{JMAX} = 150°C, θ_{JA} = 130°C/W (N8) T_{JMAX} = 150°C, θ_{JA} = 175°C/W (S8)</p>		 <p>MS8 PACKAGE 8-LEAD PLASTIC MSOP</p> <p>T_{JMAX} = 150°C, θ_{JA} = 250°C/W</p>	
ORDER PART NUMBER	DD8 PART MARKING*	ORDER PART NUMBER	S8 PART MARKING	ORDER PART NUMBER	MS8 PART MARKING*
LTC1440CDD LTC1440IDD	LBTH	LTC1440CN8 LTC1440CS8 LTC1440IN8 LTC1440IS8	1440 1440 1440I 1440I	LTC1440CMS8 LTC1440IMS8	LTBX
 <p>N8 PACKAGE 8-LEAD PDIP S8 PACKAGE 8-LEAD PLASTIC SO</p> <p>T_{JMAX} = 150°C, θ_{JA} = 130°C/W (N8) T_{JMAX} = 150°C, θ_{JA} = 175°C/W (S8)</p>		ORDER PART NUMBER	 <p>N8 PACKAGE 8-LEAD PDIP S8 PACKAGE 8-LEAD PLASTIC SO</p> <p>T_{JMAX} = 150°C, θ_{JA} = 130°C/W (N8) T_{JMAX} = 150°C, θ_{JA} = 175°C/W (S8)</p>		ORDER PART NUMBER
		LTC1441CN8 LTC1441CS8 LTC1441IN8 LTC1441IS8			LTC1442CN8 LTC1442CS8 LTC1442IN8 LTC1442IS8
		S8 PART MARKING			S8 PART MARKING
		1441 1441I			1442 1442I
<p>Order Options Tape and Reel: Add #TR Lead Free: Add #PBF Lead Free Tape and Reel: Add #TRPBF Lead Free Part Marking: http://www.linear.com/leadfree/</p>					

Consult LTC Marketing for parts specified with wider operating temperature ranges.

* The temperature grade is identified by a label on the shipping container.

144012fd

ELECTRICAL CHARACTERISTICS

The ● denotes the specifications which apply over the full operating temperature range, otherwise specifications are at $T_A = 25^\circ\text{C}$. $V^+ = 5\text{V}$ and $V^- = \text{GND} = 0\text{V}$ unless otherwise noted.

SYMBOL	PARAMETER	CONDITIONS	MIN	TYP	MAX	UNITS	
Power Supply							
V^+	Supply Voltage Range		● 2.0		11.0	V	
I_{CC}	Supply Current	$I_{N^+} = I_{N^-} + 80\text{mV}$ HYST = REF (LTC1440/LTC1442)	LTC1440	$0^\circ\text{C} \leq T_A \leq 70^\circ\text{C}$	● 2.1	4.0	μA
				$-40^\circ\text{C} \leq T_A \leq 85^\circ\text{C}$	●	4.4	μA
		LTC1441		● 3.5	5.7	μA	
		LTC1442		● 3.5	5.7	μA	
Comparator							
V_{OS}	Comparator Input Offset Voltage	$V_{CM} = 2.5\text{V}$	●	± 3	± 10	mV	
I_{IN}	Input Leakage Current (I_{N^+} , I_{N^-})	$V_{IN^+} = V_{IN^-} = 2.5\text{V}$	●	± 0.01	± 1.0	nA	
	Input Leakage Current (HYST)		●	± 0.02	± 1.0	nA	
V_{CM}	Comparator Input Common Mode Range		●	V^-	$V^+ - 1.3\text{V}$	V	
CMRR	Common Mode Rejection Ratio	V^- to $V^+ - 1.3\text{V}$		0.1	1	mV/V	
PSRR	Power Supply Rejection Ratio	$V^+ = 2\text{V}$ to 11V (LTC1441)		0.1	1	mV/V	
		$V^+ = 2.5\text{V}$ to 11V (LTC1440/LTC1442)		0.1	1	mV/V	
NOISE	Voltage Noise	100Hz to 100kHz		100		μV_{RMS}	
V_{HYST}	Hysteresis Input Voltage Range	LTC1440/LTC1442	●	REF - 50mV	REF	V	
t_{PD}	Propagation Delay	$C_{OUT} = 100\text{pF}$	Overdrive = 10mV		15	μs	
			Overdrive = 100mV		8	μs	
V_{OH}	Output High Voltage	$I_O = -13\text{mA}$	●	$V^+ - 0.4\text{V}$		V	
V_{OL}	Output Low Voltage	$I_O = 1.8\text{mA}$	LTC1440	●		GND + 0.4V	V
			LTC1441/LTC1442	●		$V^- + 0.4\text{V}$	V
Reference							
V_{REF}	Reference Voltage	No Load	LTC1440/LTC1442	$0^\circ\text{C} \leq T_A \leq 70^\circ\text{C}$	● 1.170	1.194	V
				$-40^\circ\text{C} \leq T_A \leq 85^\circ\text{C}$	● 1.164	1.200	V
			LTC1440 (MSOP, DFN)		● 1.164	1.200	V
I_{SOURCE}	Reference Output Source Current	$\Delta V_{REF} \leq 1\text{mV}$ (LTC1442)	●	100		μA	
I_{SINK}	Reference Output Sink Current	$\Delta V_{REF} \leq 2.5\text{mV}$ (LTC1442)		10	20	μA	
ΔV_{REF}	Reference Source Current	$0 \leq I_{SOURCE} \leq 2\text{mA}$ (LTC1440)	●	0.8	5	mV	
	Reference Sink Current	$0 \leq I_{SINK} \leq 10\mu\text{A}$ (LTC1440)	●	0.5	1.5	mV	
NOISE	Voltage Noise	100Hz to 100kHz		100		μV_{RMS}	

LTC1440/LTC1441/LTC1442

ELECTRICAL CHARACTERISTICS The ● denotes the specifications which apply over the full operating temperature range, otherwise specifications are at $T_A = 25^\circ\text{C}$. $V^+ = 3\text{V}$ and $V^- = \text{GND} = 0\text{V}$ unless otherwise noted.

SYMBOL	PARAMETER	CONDITIONS		MIN	TYP	MAX	UNITS	
Power Supply								
V^+	Supply Voltage Range		●	2		11	V	
I_{CC}	Supply Current	$I_{\text{N}^+} = I_{\text{N}^-} + 80\text{mV}$ HYST = REF (LTC1440/LTC1442)	LTC1440 $0^\circ\text{C} \leq T_A \leq 70^\circ\text{C}$ $-40^\circ\text{C} \leq T_A \leq 85^\circ\text{C}$	●	2	3.9	μA	
				●		4.3	μA	
		LTC1441	●	3.5	5.7	μA		
LTC1442	●	3.5	5.7	μA				
Comparator								
V_{OS}	Comparator Input Offset Voltage	$V_{\text{CM}} = 1.5\text{V}$	●		± 3	± 10	mV	
I_{IN}	Input Leakage Current (I_{N^+} , I_{N^-})	$V_{\text{IN}^+} = V_{\text{IN}^-} = 1.5\text{V}$	●		± 0.01	± 1	nA	
	Input Leakage Current (HYST)		●		± 0.02	± 1	nA	
V_{CM}	Comparator Input Common Mode Range		●	V^-		$V^+ - 1.3\text{V}$	V	
CMRR	Common Mode Rejection Ratio	V^- to $V^+ - 1.3\text{V}$			0.1	1	mV/V	
PSRR	Power Supply Rejection Ratio	$V^+ = 2\text{V}$ to 11V (LTC1441)			0.1	1	mV/V	
		$V^+ = 2.5\text{V}$ to 11V (LTC1440/LTC1442)			0.1	1	mV/V	
NOISE	Voltage Noise	100Hz to 100kHz			100		μV_{RMS}	
V_{HYST}	Hysteresis Input Voltage Range	LTC1440/LTC1442	●	REF - 50mV		REF	V	
t_{PD}	Propagation Delay	$C_{\text{OUT}} = 100\text{pF}$			Overdrive = 10mV	14	μs	
					Overdrive = 100mV	5	μs	
V_{OH}	Output High Voltage	$I_{\text{O}} = -8\text{mA}$	●	$V^+ - 0.4\text{V}$			V	
Comparator								
V_{OL}	Output Low Voltage	$I_{\text{O}} = 0.8\text{mA}$				$\text{GND} + 0.4\text{V}$	V	
			●			$V^- + 0.4\text{V}$	V	
Reference								
V_{REF}	Reference Voltage	No Load	LTC1440/LTC1442 $0^\circ\text{C} \leq T_A \leq 70^\circ\text{C}$ $-40^\circ\text{C} \leq T_A \leq 85^\circ\text{C}$	●	1.170	1.182	1.194	V
				●	1.164		1.200	V
				LTC1440 (MSOP, DFN)	●	1.164		1.200
I_{SOURCE}	Reference Output Source Current	$\Delta V_{\text{REF}} \leq 1\text{mV}$ (LTC1442)	●	60	120		μA	
I_{SINK}	Reference Output Sink Current	$\Delta V_{\text{REF}} \leq 2.5\text{mV}$ (LTC1442)		10	20		μA	
ΔV_{REF}	Reference Source Current	$0 \leq I_{\text{SOURCE}} \leq 1\text{mA}$ (LTC1440)	●		0.8	5.5	mV	
	Reference Sink Current	$0 \leq I_{\text{SINK}} \leq 10\mu\text{A}$ (LTC1440)	●		0.5	1.5	mV	
NOISE	Voltage Noise	100Hz to 100kHz			100		μV_{RMS}	

Note 1: Stresses beyond those listed under Absolute Maximum Ratings may cause permanent damage to the device. Exposure to any Absolute Maximum Rating condition for extended periods may affect device reliability and lifetime.

TYPICAL PERFORMANCE CHARACTERISTICS

Comparator Response Time vs Input Overdrive

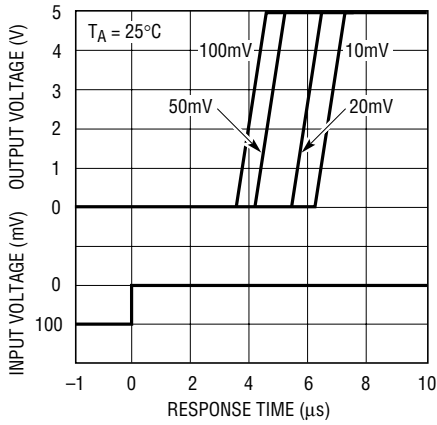

1440/1/2 G01

Comparator Response Time vs Input Overdrive

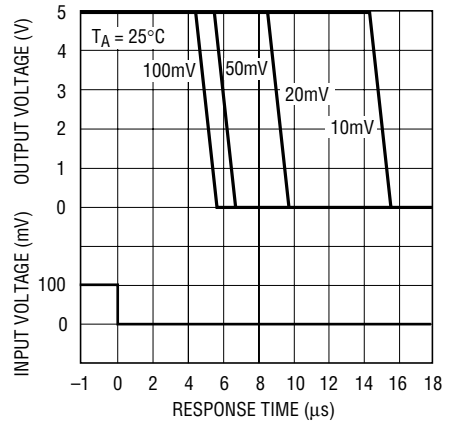

1440/1/2 G02

Comparator Short-Circuit Sink Current vs Supply Voltage

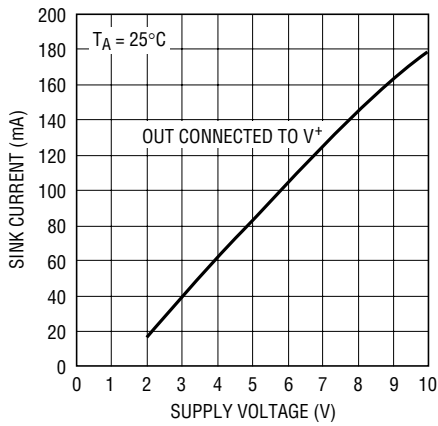

1440/1/2 G03

Comparator Short-Circuit Source Current vs Supply Voltage

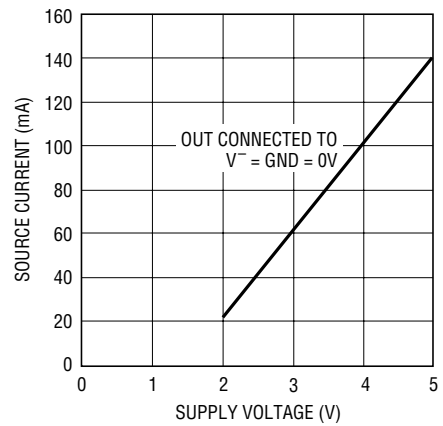

1440/1/2 G04

TYPICAL PERFORMANCE CHARACTERISTICS

Comparator Response Time vs Load Capacitance with 100mV Input Overdrive

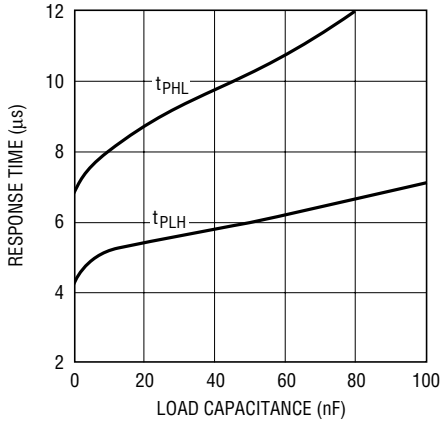

1440/1/2 G05

Comparator Response Time at Low Supply Voltage

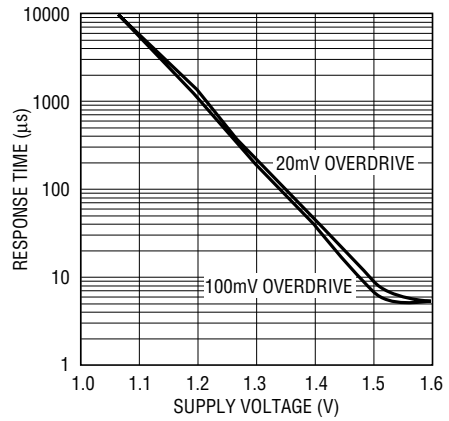

1440/1/2 G06

Comparator Output Voltage High vs Load Current

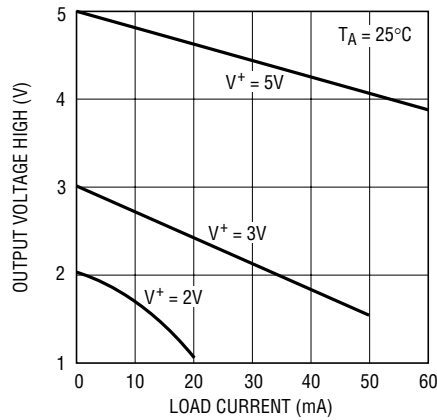

1440/1/2 G07

TYPICAL PERFORMANCE CHARACTERISTICS

Comparator Output Voltage Low vs Load Current

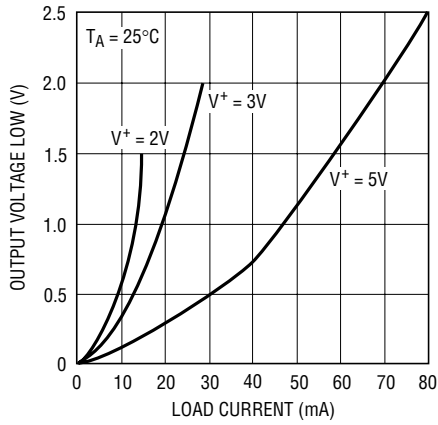

1440/1/2 G08

LTC1440/LTC1442 Hysteresis Control

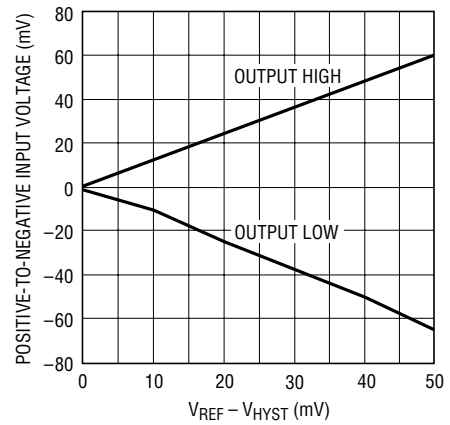

1440/1/2 G09

LTC1440 Supply Current vs Temperature

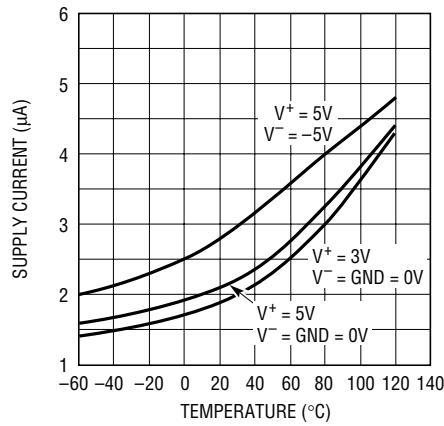

1440/1/2 G10

TYPICAL PERFORMANCE CHARACTERISTICS

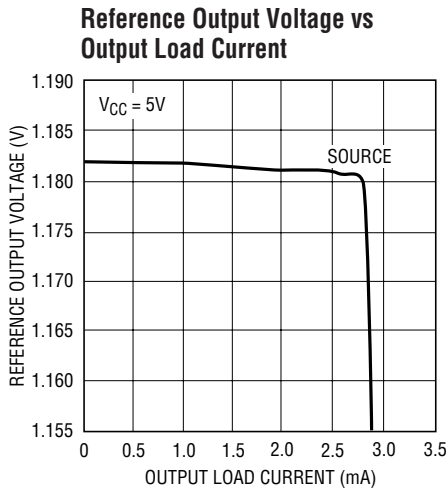

1440/1/2 G11

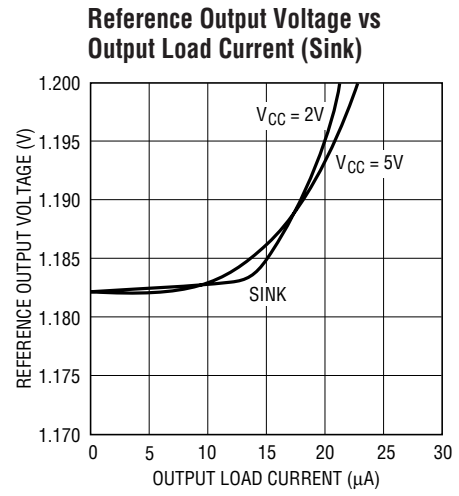

1440/1/2 G12

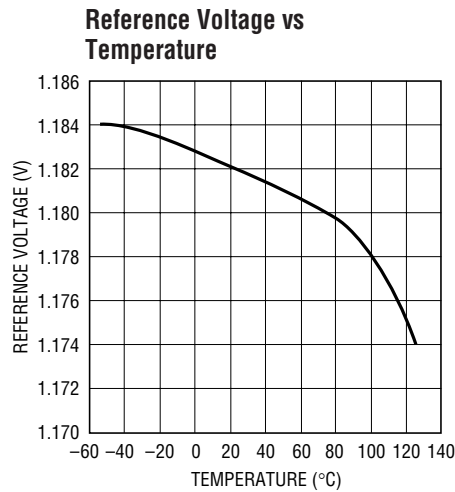

1440/1/2 G13

PIN FUNCTIONS

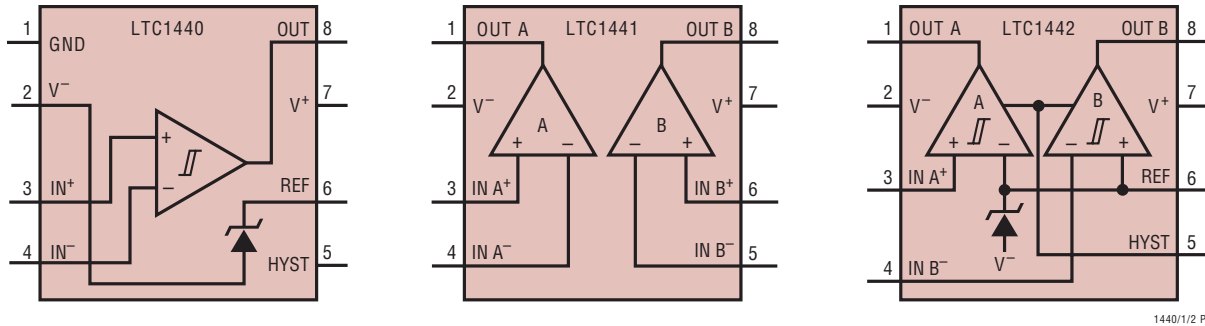
**LTC1440**

GND (Pin 1): Ground. Connect to V^- for single supply operation.

V^- (Pin 2): Negative Supply. Connect to ground for single supply operation. Potential should be more negative than GND.

IN^+ (Pin 3): Noninverting Comparator Input. Input common mode range from V^- to $V^+ - 1.3V$. Input current typically 10pA at 25°C.

IN^- (Pin 4): Inverting Comparator Input. Input common mode range from V^- to $V^+ - 1.3V$. Input current typically 10pA at 25°C.

HYST (Pin 5): Hysteresis Input. Connect to REF if not used. Input voltage range is from V_{REF} to $V_{REF} - 50mV$.

REF (Pin 6): Reference Output. 1.182V with respect to V^- . Can source up to 200 μA and sink 15 μA at 25°C. Drive 0.01 μF bypass capacitor without oscillation.

V^+ (Pin 7): Positive Supply. 2V to 11V.

OUT (Pin 8): Comparator CMOS Output. Swings from GND to V^+ . Output can source up to 40mA and sink 5mA.

LTC1441

OUT A (Pin 1): Comparator A CMOS Output. Swings from V^- to V^+ . Output can source up to 40mA and sink 5mA.

V^- (Pin 2): Negative Supply.

$IN A^+$ (Pin 3): Noninverting Input of Comparator A. Input common mode range from V^- to $V^+ - 1.3V$. Input current typically 10pA at 25°C.

$IN A^-$ (Pin 4): Inverting Input of Comparator A. Input common mode range from V^- to $V^+ - 1.3V$. Input current typically 10pA at 25°C.

$IN B^-$ (Pin 5): Inverting Input of Comparator B. Input common mode range from V^- to $V^+ - 1.3V$. Input current typically 10pA at 25°C.

$IN B^+$ (Pin 6): Noninverting Input of Comparator B. Input common mode range from V^- to $V^+ - 1.3V$. Input current typically 10pA at 25°C.

V^+ (Pin 7): Positive Supply. 2V to 11V.

OUT B (Pin 8): Comparator B CMOS Output. Swings from V^- to V^+ . Output can source up to 40mA and sink 5mA.

LTC1442

OUT A (Pin 1): Comparator A CMOS Output. Swings from V^- to V^+ . Output can source up to 40mA and sink 5mA.

V^- (Pin 2): Negative Supply.

$IN A^+$ (Pin 3): Noninverting Input of Comparator A. Input common mode range from V^- to $V^+ - 1.3V$. Input current typically 10pA at 25°C.

$IN B^-$ (Pin 4): Inverting Input of Comparator B. Input common mode range from V^- to $V^+ - 1.3V$. Input current typically 10pA at 25°C.

HYST (Pin 5): Hysteresis Input. Connect to REF if not used. Input voltage range is from V_{REF} to $V_{REF} - 50mV$.

REF (Pin 6): Reference Output. 1.182V with respect to V^- . Can source up to 200 μA and sink 15 μA at 25°C. Drive 0.01 μF bypass capacitor without oscillation.

V^+ (Pin 7): Positive Supply. 2V to 11V.

OUT B (Pin 8): Comparator B CMOS Output. Swings from V^- to V^+ . Output can source up to 40mA and sink 5mA.

APPLICATIONS INFORMATION

LTC1440/LTC1441/LTC1442 are a family of micropower comparators with built-in 1.182V reference. Features include programmable hysteresis (LTC1440/LTC1442), wide supply voltage range (2V to 11V) and the ability of the reference to drive up to a 0.01 μ F capacitor without oscillation. The comparators' CMOS outputs can source up to 40mA and the supply current glitches, that normally occur when switching logic states, have been eliminated.

Power Supplies

The comparator family operates from a single 2V to 11V supply. The LTC1440 includes a separate ground for the comparator output stage, allowing a split supply ranging from ± 1 V to ± 5.5 V. Connecting V^- to GND on the LTC1440 will allow single supply operation. If the comparator output is required to source more than 1mA, or the supply source impedance is high, V^+ should be bypassed with a 0.1 μ F capacitor.

Comparator Inputs

The comparator inputs can swing from the negative supply V^- to within 1.3V max of the positive supply V^+ . The inputs can be forced 300mV below V^- or above V^+ without damage and the typical input leakage current is only ± 10 pA.

Comparator Outputs

The LTC1440 comparator output swings between GND and V^+ to assure TTL compatibility with a split supply. The LTC1441 and LTC1442 outputs swing between V^- and V^+ . The outputs are capable of sourcing up to 40mA and sinking up to 5mA while still maintaining microampere quiescent currents. The output stage does not generate crowbar switching currents during transitions which helps minimize parasitic feedback through the supply pins.

Voltage Reference

The internal bandgap reference has a voltage of 1.182V referenced to V^- . The reference accuracy is 1.5% from -40°C to 85°C . It can source up to 200 μ A and sink up to 20 μ A with a 5V supply. The reference can drive a bypass

capacitor of up to 0.01 μ F without oscillation and by inserting a series resistor, capacitance values up to 100 μ F can be used (Figure 1).

Figure 2 shows the resistor value required for different capacitor values to achieve critical damping. Bypassing the reference can help prevent false tripping of the comparators by preventing glitches on V^+ or reference load transients from disturbing the reference output voltage.

Figure 3 shows the bypassed reference output with a square wave applied to the V^+ pin. Resistors R2 and R3 set 10mV of hysteresis voltage band while R1 damps the reference response. Note that the comparator output doesn't trip.

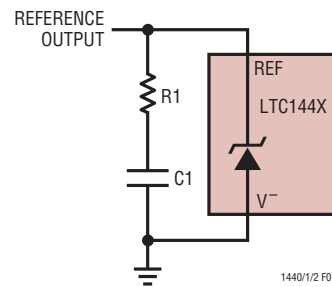

Figure 1. Damping the Reference Output

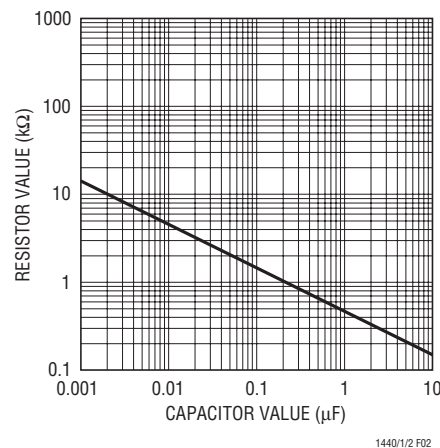

Figure 2. Damping Resistance vs Bypass Capacitor Value

APPLICATIONS INFORMATION

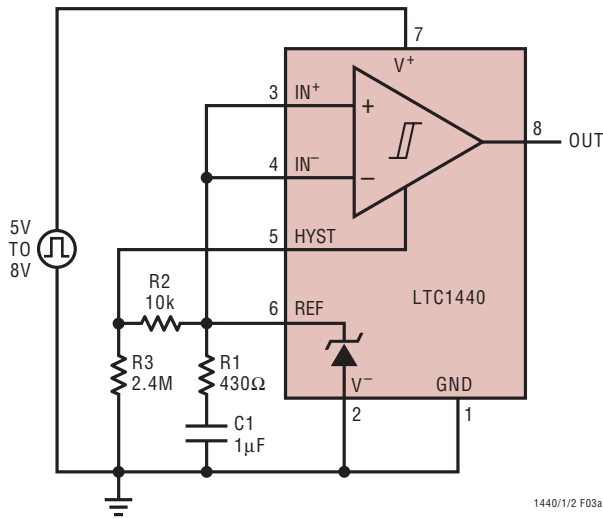

Figure 3a. Reference Transient Response Test Circuit

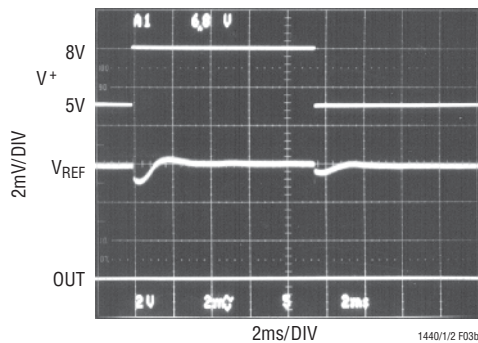

Figure 3b. Reference and Comparator Output Transient Response

Hysteresis

Hysteresis can be added to the LTC1440 by connecting a resistor (R1) between the REF and HYST pins and a second resistor (R2) from HYST to V⁻ (Figure 4).

The difference between the upper and lower threshold voltages, or hysteresis voltage band (V_{HB}), is equal to twice the voltage difference between the REF and HYST pins.

When more hysteresis is added, the upper threshold increases the same amount as the low threshold decreases. The maximum voltage allowed between REF and HYST pins is 50mV, producing a maximum hysteresis voltage band of 100mV. The hysteresis band could vary by

up to 15%. If hysteresis is not wanted, the HYST pin should be shorted to REF. Acceptable values for I_{REF} range from 0.1μA to 5μA. If 2.4M is chosen for R2, then the value of R1 is equal to the value of V_{HB}.

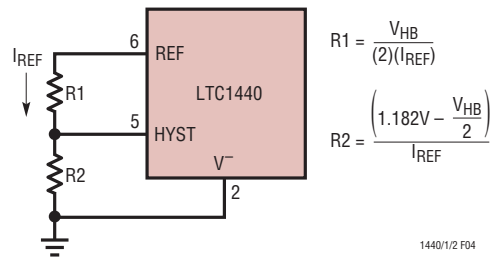

Figure 4. Programmable Hysteresis

Level Detector

The LTC1440 is ideal for use as a micropower level detector as shown in Figure 5. R1 and R2 form a voltage divider from V_{IN} to the noninverting comparator input. R3 and R4 set the hysteresis voltage, and R5 and C1 bypass the reference output. The following design procedure can be used to select the component values:

1. Choose the V_{IN} voltage trip level, in this example 4.65V.

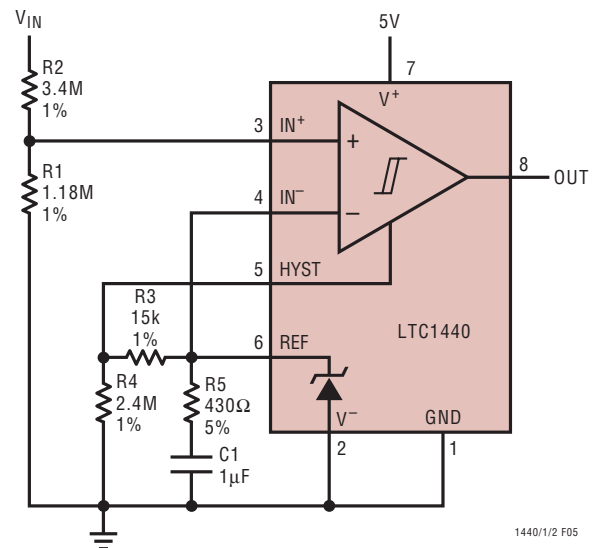

Figure 5. Glitch-Free Level Detector with Hysteresis

APPLICATIONS INFORMATION

2. Calculate the required resistive divider ratio.

$$\text{Ratio} = V_{\text{REF}}/V_{\text{IN}}$$

$$\text{Ratio} = 1.182\text{V}/4.65\text{V} = 0.254$$

3. Choose the required hysteresis voltage band at the input V_{HBIN} , in this example 60mV. Calculate the hysteresis voltage band referred to the comparator input V_{HB} .

$$V_{\text{HB}} = (V_{\text{HBIN}})(\text{Ratio})$$

$$V_{\text{HB}} = (60\text{mV})(0.254)$$

$$V_{\text{HB}} = 15.24\text{mV}$$

4. Choose the values for R3 and R4 to set the hysteresis.

$$R4 = 2.4\text{M}$$

$$R3(\text{k}\Omega) = V_{\text{HB}} = 15\text{k}$$

5. Choose the values for R1 and R2 to set the trip point.

$$R1 = \frac{V_{\text{REF}}}{I_{\text{BIAS}}} = \frac{1.182\text{V}}{1\mu\text{A}} = 1.18\text{M}$$

$$R2 = R1 \left[\frac{V_{\text{IN}}}{V_{\text{REF}} + \frac{V_{\text{HB}}}{2}} - 1 \right]$$

$$R2 = 1.18\text{M} \left[\frac{4.65\text{V}}{1.182\text{V} + \frac{15\text{mV}}{2}} - 1 \right]$$

$$R2 = 3.40\text{M}$$

Low Voltage Operation

It is important to note that the voltage references internal to the LTC1440 and LTC1442 can exceed the common mode range of the comparators at low supply voltages. The input common mode range of the LTC1440/LTC1441/LTC1442 comparators is guaranteed to extend up to $(V^+ - 1.3\text{V})$. Therefore, if one of the comparator inputs is at the 1.182V reference voltage, the minimum supply voltage is 2.5V for a valid output reading.

The guaranteed minimum operating voltage for the LTC1440/LTC1441/LTC1442 is 2V (or $\pm 1\text{V}$). However, both the reference and comparator(s) will function with a supply voltage as low as 1.5V, but performance will degrade as the voltage goes below 2V. The voltage reference temperature coefficient will degrade slightly, and the comparators will have less output drive with an increase in propagation delay. At the reduced supply voltages, the input common mode range of the comparator(s) will still typically extend from the negative supply to approximately 1.1V below the positive supply.

TYPICAL APPLICATIONS

10-Bit 30 μ A A/D Converter

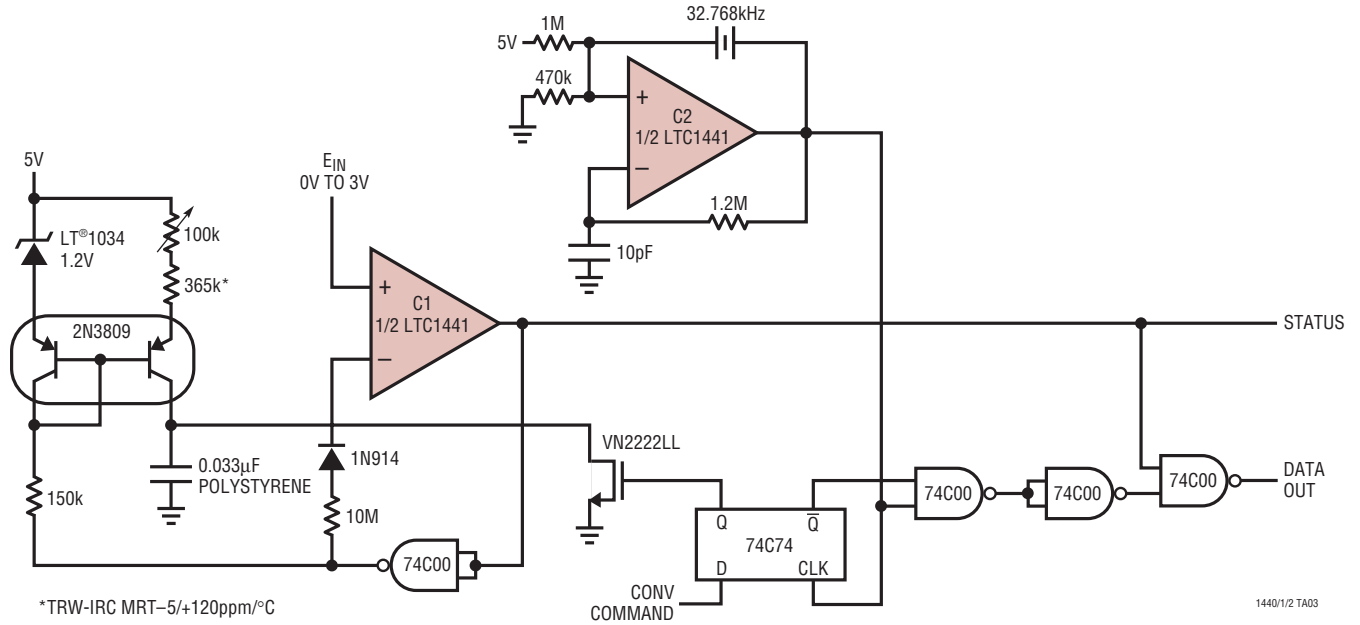

32.768kHz “Watch Crystal” Oscillator

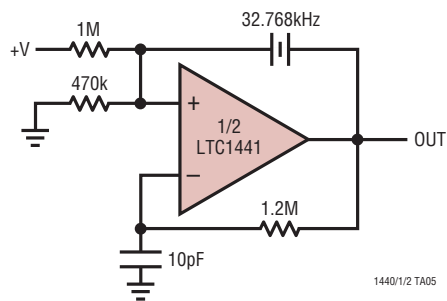

PACKAGE DESCRIPTION

DD Package 8-Lead Plastic DFN (3mm × 3mm) (Reference LTC DWG # 05-08-1698)

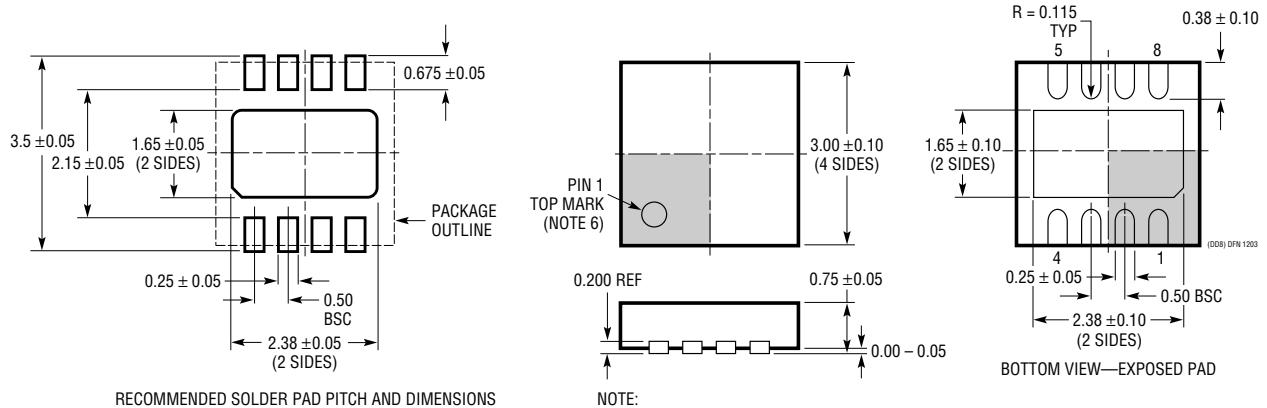

NOTE:

1. DRAWING TO BE MADE A JEDEC PACKAGE OUTLINE M0-229 VARIATION OF (WEED-1)
2. DRAWING NOT TO SCALE
3. ALL DIMENSIONS ARE IN MILLIMETERS
4. DIMENSIONS OF EXPOSED PAD ON BOTTOM OF PACKAGE DO NOT INCLUDE MOLD FLASH. MOLD FLASH, IF PRESENT, SHALL NOT EXCEED 0.15mm ON ANY SIDE
5. EXPOSED PAD SHALL BE SOLDER PLATED
6. SHADED AREA IS ONLY A REFERENCE FOR PIN 1 LOCATION ON TOP AND BOTTOM OF PACKAGE

MS8 Package 8-Lead Plastic MSOP (Reference LTC DWG # 05-08-1660)

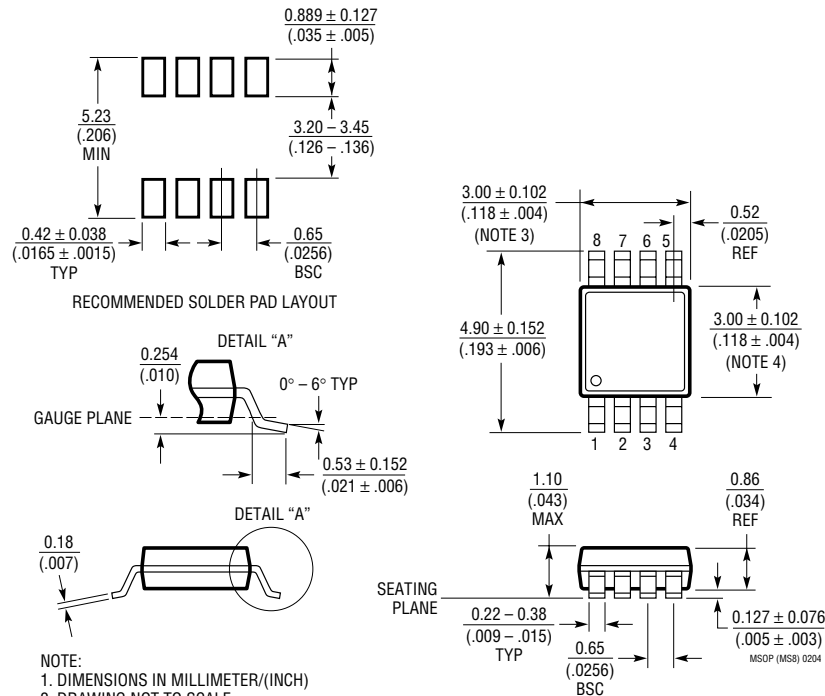

NOTE:

1. DIMENSIONS IN MILLIMETER/(INCH)
2. DRAWING NOT TO SCALE
3. DIMENSION DOES NOT INCLUDE MOLD FLASH, PROTRUSIONS OR GATE BURRS. MOLD FLASH, PROTRUSIONS OR GATE BURRS SHALL NOT EXCEED 0.152mm (.006") PER SIDE
4. DIMENSION DOES NOT INCLUDE INTERLEAD FLASH OR PROTRUSIONS. INTERLEAD FLASH OR PROTRUSIONS SHALL NOT EXCEED 0.152mm (.006") PER SIDE
5. LEAD COPLANARITY (BOTTOM OF LEADS AFTER FORMING) SHALL BE 0.102mm (.004") MAX

PACKAGE DESCRIPTION

N8 Package 8-Lead PDIP (Narrow 0.300) (LTC DWG # 05-08-1510)

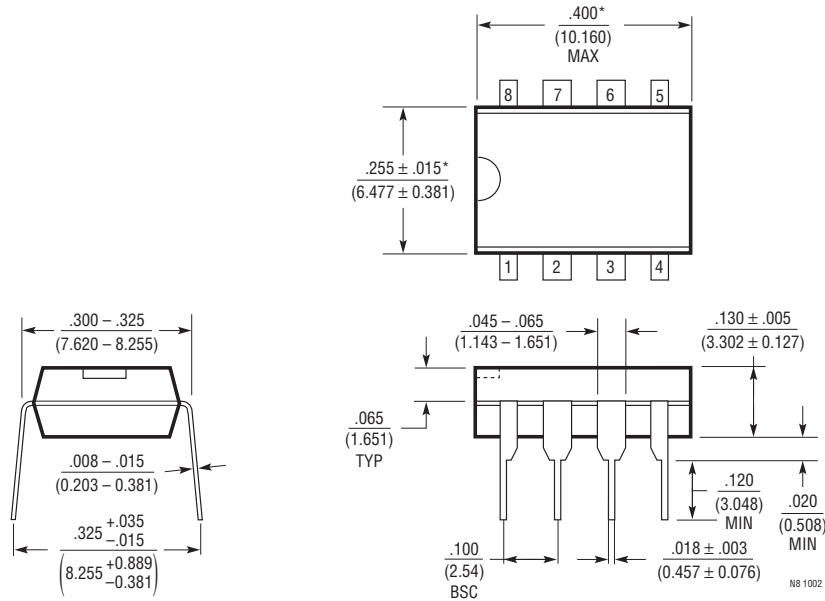

NOTE:
1. DIMENSIONS ARE $\frac{\text{INCHES}}{\text{MILLIMETERS}}$
*THESE DIMENSIONS DO NOT INCLUDE MOLD FLASH OR PROTRUSIONS.
MOLD FLASH OR PROTRUSIONS SHALL NOT EXCEED .010 INCH (0.254mm)

S8 Package 8-Lead Plastic Small Outline (Narrow 0.150) (LTC DWG # 05-08-1610)

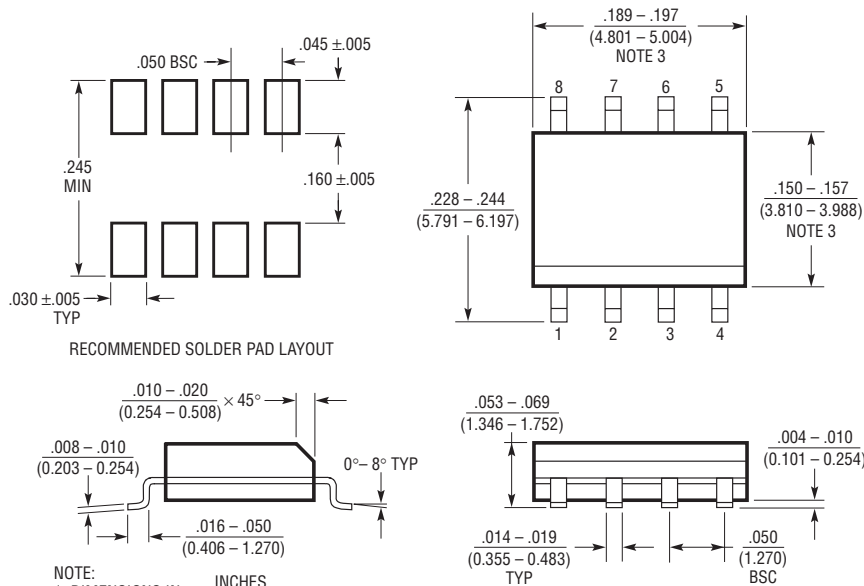

NOTE:
1. DIMENSIONS IN $\frac{\text{INCHES}}{\text{MILLIMETERS}}$
2. DRAWING NOT TO SCALE
3. THESE DIMENSIONS DO NOT INCLUDE MOLD FLASH OR PROTRUSIONS.
MOLD FLASH OR PROTRUSIONS SHALL NOT EXCEED .006" (0.15mm)

TYPICAL APPLICATION

10kHz V/F Converter

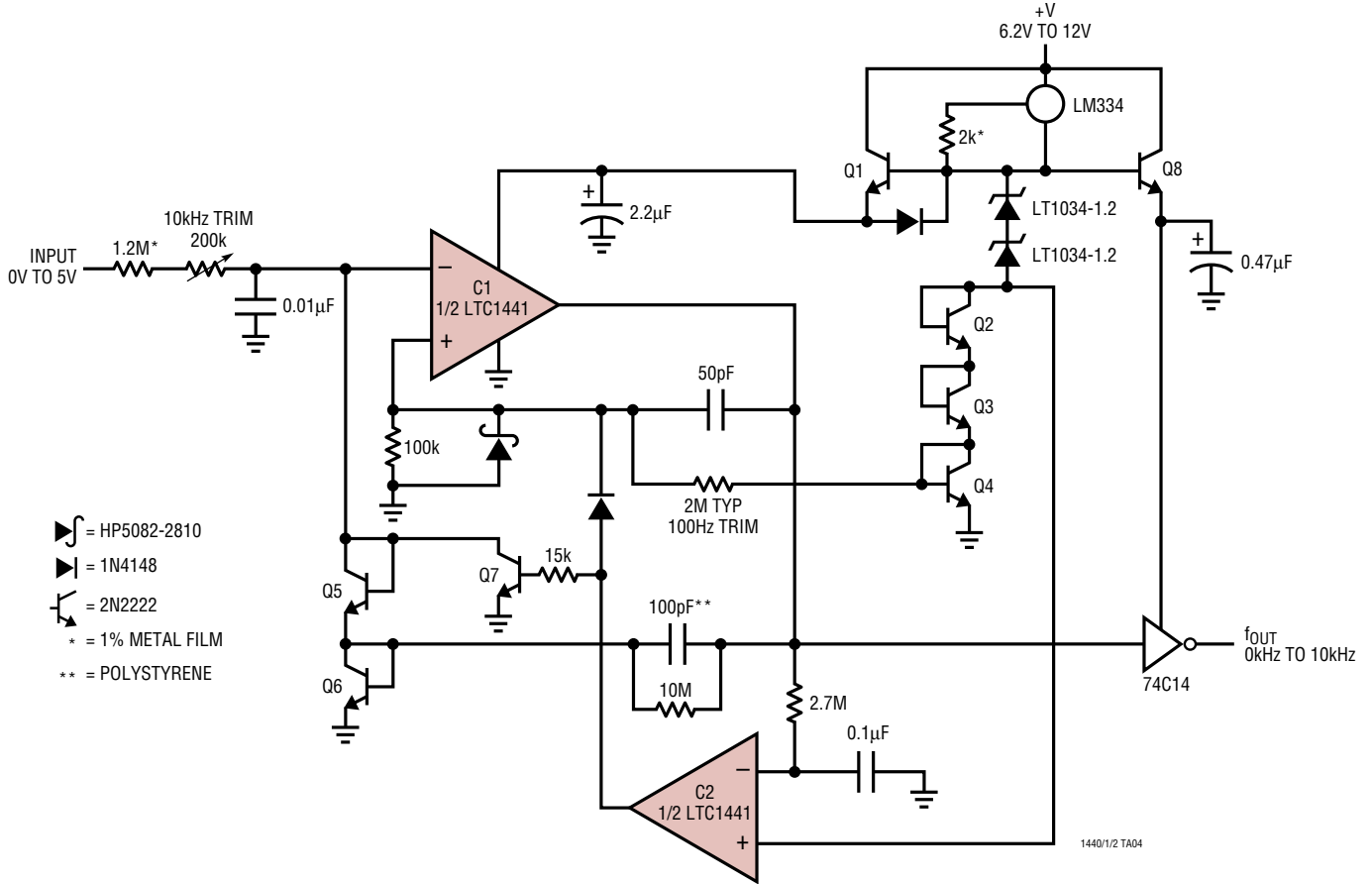

RELATED PARTS

PART NUMBER	DESCRIPTION	COMMENTS
LTC1443	1.182V Reference with Micropower Quad Comparators	1% Accuracy, 8.5µA Maximum Current, Ref Output Drives 0.01µF
LTC1444/LTC1445	1.2V Reference with Quad Comparator with Adjustable Hysteresis	1% Accuracy, 8.5µA Maximum Current, Ref Output Drives 0.01µF
LTC1540	1.182V Reference with Nanopower Comparator with Adjustable Hysteresis	DFN Package 0.3µA Quiescent Current (Typical), Reference Drives 0.01µF
LTC1541	1.2V Reference with Micropower Amplifier and Comparator	DFN Package 1.25% Accuracy, Rail-to-Rail Out, Low Offset Amplifier
LTC1842/LTC1843	1.82V Reference with Dual Comparators with Adjustable Hysteresis	1% Accuracy, Open-Drain Out, Reference Drives 0.01µF
LTC1998	1.2 Reference with Comparator with Adjustable Thesholds	Li-Ion Low Battery Monitor, SOT23, 1% Accuracy
LT6700-1 LT6700-2/LT6700-3	0.4 Reference with Low Voltage Dual Comparators	SOT23, 1.4V to 18.5V Supply Range, ±2% Over Temperature