

Step-Up/Step-Down Switched Capacitor DC/DC Converters with Reset

FEATURES

- Adjustable/Selectable 3V, 3.3V or 5V Output Voltages
- 2V to 10V Input Voltage Range
- Up to 50mA Output Current
- Only Three External Capacitors Required
- Soft Start Limits Inrush Current at Turn-On
- Low Operating Current: 60 μ A
- Very Low Shutdown Current: < 1 μ A
- Shutdown Disconnects Load from V_{IN}
- V_{OUT} Programmable to 3V/5V or 3.3V/5V
- Short-Circuit and Overtemperature Protected
- 650kHz Switching Frequency
- Open-Drain Power-On Reset Output
- Available in SO-8 Package

APPLICATIONS

- SIM Interface in GSM Cellular Telephones
- Smart Card Readers
- Local Power Supplies
- Portable Equipment

DESCRIPTION

The LTC[®]1515, LTC1515-3/5 and LTC1515-3.3/5 are micropower switched capacitor DC/DC converters that produce a regulated output voltage by either stepping up or stepping down the input voltage. Output voltage is adjustable using an external resistor divider (LTC1515) or programmable to either 3V/5V (LTC1515-3/5) or 3.3V/5V (LTC1515-3.3/5) using a logic pin.

A unique architecture allows the parts to accommodate a wide input voltage range (2V to 10V) while maintaining $\pm 4\%$ regulation. Additional circuitry prevents excessive inrush current and output voltage ripple when large V_{IN} to V_{OUT} differentials are present.

An internal power-on reset circuit forces the POR pin low on initial power-up. The POR output remains low until 200ms (typ) after V_{OUT} is in regulation.

The parts are short-circuit and overtemperature protected. Battery life is maximized by very low operating currents ($I_{CC} = 60\mu\text{A}$ typ, $I_{CC} < 1\mu\text{A}$ in shutdown). All three parts are available in an SO-8 package.

LT, LTC and LT are registered trademarks of Linear Technology Corporation.

TYPICAL APPLICATION

Programmable 3.3V/5V Power Supply with Power-On Reset

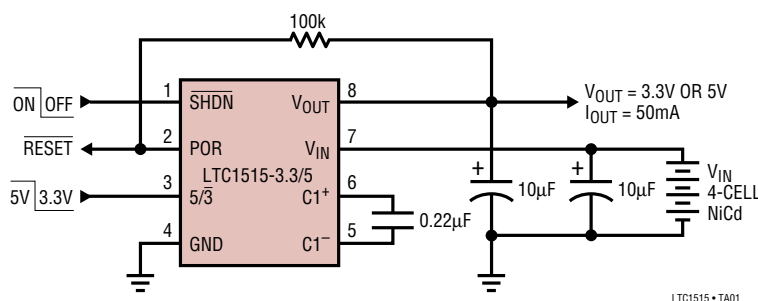

LTC1515-X 5V Output vs Input Voltage

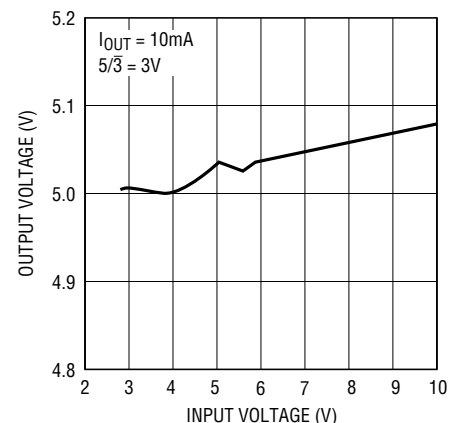

LT1515 • TA02

LTC1515 Series

ABSOLUTE MAXIMUM RATINGS

(Note 1)

V_{IN} to GND	-0.3V to 12V
V_{OUT} to GND	-0.3V to 12V
SHDN, 5/3, FB to GND	-0.3V to 12V
V_{OUT} Short-Circuit Duration	Indefinite

Operating Temperature Range

Commercial	0°C to 70°C
Industrial	-40°C to 85°C
Storage Temperature Range	-65°C to 150°C
Lead Temperature (Soldering, 10 sec)	300°C

PACKAGE/ORDER INFORMATION

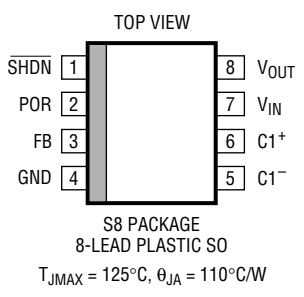
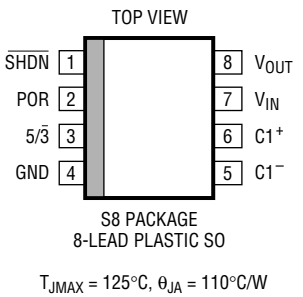
 <p>S8 PACKAGE 8-LEAD PLASTIC SO $T_{JMAX} = 125^{\circ}C, \theta_{JA} = 110^{\circ}C/W$</p>	ORDER PART NUMBER	 <p>S8 PACKAGE 8-LEAD PLASTIC SO $T_{JMAX} = 125^{\circ}C, \theta_{JA} = 110^{\circ}C/W$</p>	ORDER PART NUMBER
	LTC1515CS8 LTC1515IS8		LTC1515CS8-3/5 LTC1515CS8-3.3/5 LTC1515IS8-3/5 LTC1515IS8-3.3/5
	S8 PART MARKING		S8 PART MARKING
	1515 1515I		151535 515135 515335 151335

Consult factory for Military grade parts.

ELECTRICAL CHARACTERISTICS

$V_{IN} = 2V$ to $10V$, $\overline{SHDN} = 3V$, $C1 = 0.22\mu F$, $C_{IN} = C_{OUT} = 10\mu F$ unless otherwise noted (Note 2).

PARAMETER	CONDITIONS	MIN	TYP	MAX	UNITS
V_{IN} Operating Voltage	$V_{OUT} = 5V$	2.7		10	V
	$V_{OUT} = 3V/3.3V$	2.0		8	V
	$V_{OUT} = ADJ$	2.0		10	V
$V_{OUT} = 3V$ (LTC1515-3/5)	$2V \leq V_{IN} \leq 8V, I_{OUT} \leq 15mA$	2.88	3.0	3.12	V
	$3V \leq V_{IN} \leq 8V, I_{OUT} \leq 50mA$	2.88	3.0	3.12	V
$V_{OUT} = 3.3V$ (LTC1515-3.3/5)	$2V \leq V_{IN} \leq 8V, I_{OUT} \leq 15mA$	3.17	3.3	3.43	V
	$3V \leq V_{IN} \leq 8V, I_{OUT} \leq 50mA$	3.17	3.3	3.43	V
$V_{OUT} = 5V$ (LTC1515-3/5, LTC1515-3.3/5)	$2.7V \leq V_{IN} \leq 10V, I_{OUT} \leq 15mA$	4.8	5.0	5.2	V
	$3.3V \leq V_{IN} \leq 10V, I_{OUT} \leq 50mA$	4.8	5.0	5.2	V
V_{FB} Feedback Voltage	LTC1515, V_{FB} Ramping Negative	1.190	1.232	1.275	V
V_{FB} Feedback Hysteresis	LTC1515		1		%
Effective Output Resistance	LTC1515, $V_{IN} = 3V$, Step-Up Mode			30	Ω
V_{IN} Operating Current	$V_{IN} \leq 5V, I_{OUT} = 0, \overline{SHDN} = 3V$		60	100	μA
	$V_{IN} > 5V, I_{OUT} = 0, \overline{SHDN} = 3V$		75	135	μA
V_{IN} Shutdown Current	$\overline{SHDN} = 0V, V_{IN} \leq 5V$			1	μA
	$\overline{SHDN} = 0V, V_{IN} > 5V$			25	μA
Output Ripple	Full Load (Note 2)		100		mV _{p-p}
Switching Frequency	Full Load	500	650	800	kHz
5/3, SHDN Input Threshold	V_{IL}	0.4	1.0		V
	V_{IH}		1.0	1.6	V
5/3, SHDN Input Current	5/3, $\overline{SHDN} = V_{IN}$	-1		1	μA
	5/3, $\overline{SHDN} = 0V$	-1		1	μA
FB Input Current	FB = 1.232V	-50		50	nA
POR Output Low Voltage	$I_{SINK} = 100\mu A, V_{IN} = 3V$		0.05	0.4	V

ELECTRICAL CHARACTERISTICS

$V_{IN} = 2V$ to $10V$, $\overline{SHDN} = 3V$, $C_1 = 0.22\mu F$, $C_{IN} = C_{OUT} = 10\mu F$ unless otherwise noted (Note 2).

PARAMETER	CONDITIONS	MIN	TYP	MAX	UNITS	
POR Leakage Current	$V_{POR} = 5V$	●	-1	1	μA	
POR Trip Point (With Respect to V_{OUT})	V_{OUT} Ramping Negative	●	-10	-7.5	%	
POR Trip Point Hysteresis			1		%	
I_{OUT} Short-Circuit Current	$V_{OUT} = 0V$	●	12	40	mA	
t_{ON}	Soft Start Turn-On Time		4		ms	
POR Delay	After V_{OUT} Above POR Threshold	●	140	200	280	ms

The ● denotes specifications which apply over the full operating temperature range.

Note 2: For $V_{IN} \geq 8V$, $C_{OUT} = 22\mu F$.

Note 1: Absolute Maximum Ratings are those values beyond which the life of the device may be impaired.

TYPICAL PERFORMANCE CHARACTERISTICS

LTC1515-X
3.3V Efficiency vs Output Current

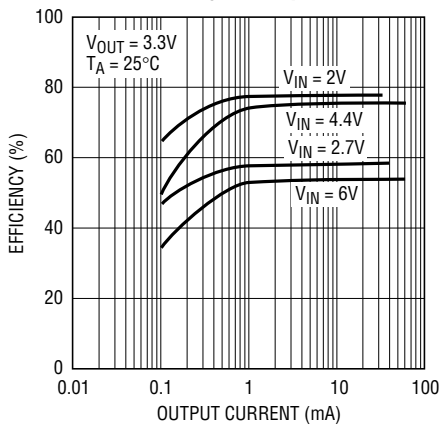

1515 G01

LTC1515-X
5V Efficiency vs Output Current

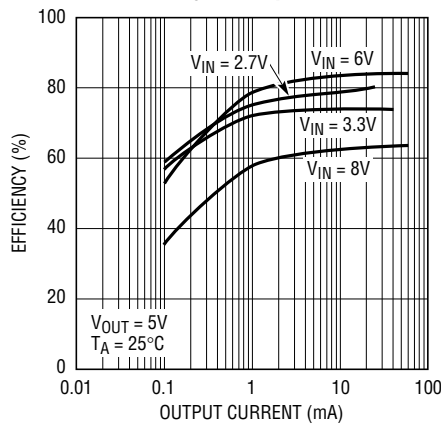

1515 G02

LTC1515-X 3.3V Output Voltage Ripple vs Input Voltage

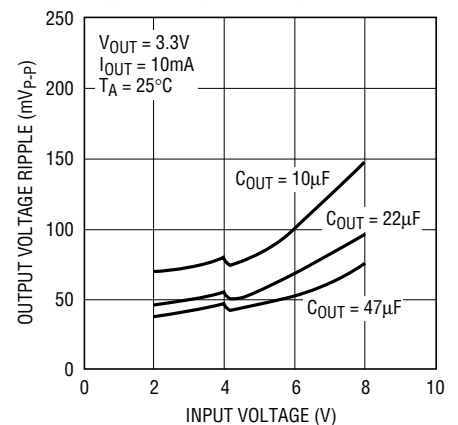

1515 G03

LTC1515-X 5V Output Voltage Ripple vs Input Voltage

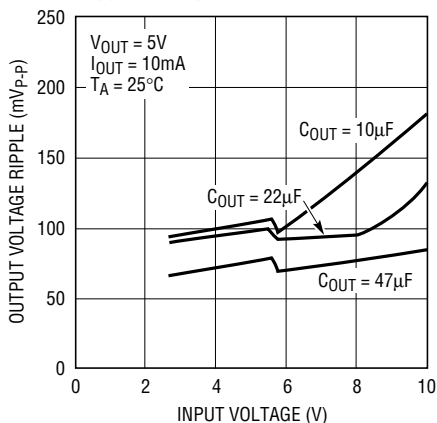

1515 G04

LTC1515-X 3.3V Output Voltage vs Input Voltage

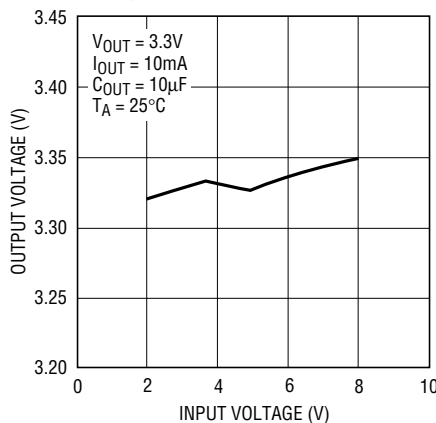

1515 G05

LTC1515-X Operating Current vs Input Voltage

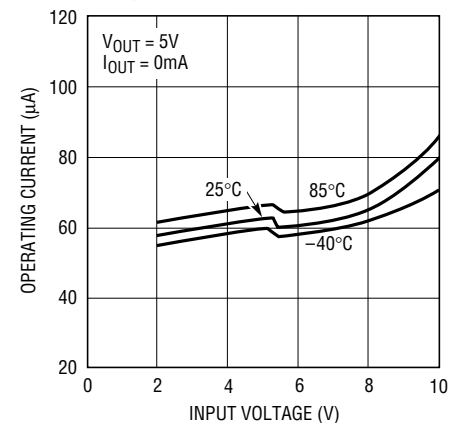

1515 G06

TYPICAL PERFORMANCE CHARACTERISTICS

LTC1515-X
3V Efficiency vs Input Voltage

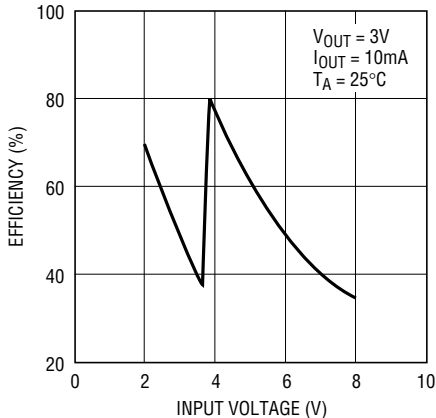

1515 G09

LTC1515-X
3.3V Efficiency vs Input Voltage

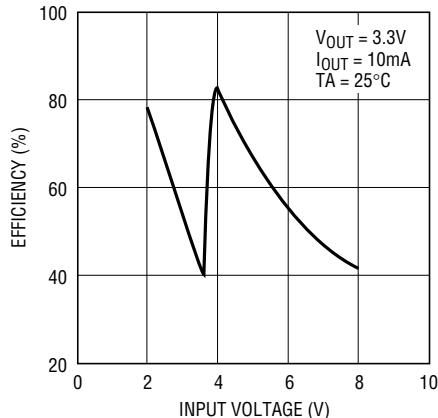

1515 G07

LTC1515-X
5V Efficiency vs Input Voltage

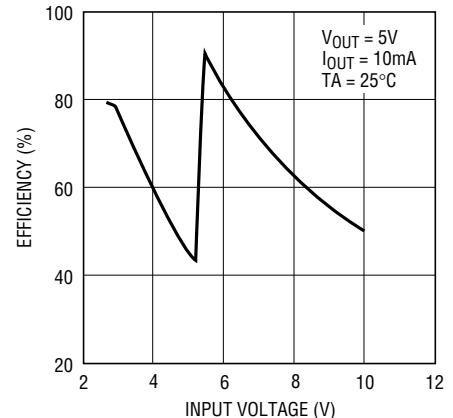

1515 G08

LTC1515-X Shutdown Supply Current vs Input Voltage

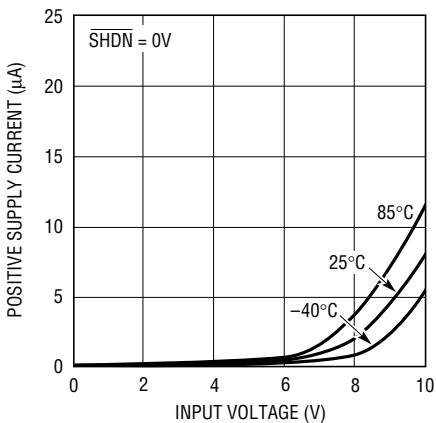

1515 G12

LTC1515-X Step-Down Mode 5V Load Transient Response

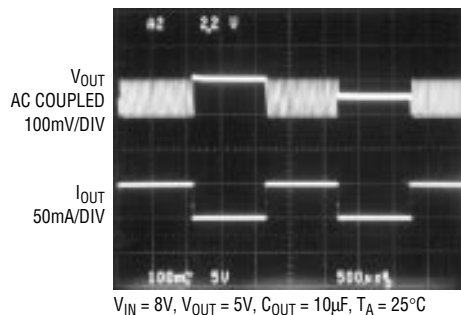

1515 G10

LTC1515-X Step-Up Mode 5V Load Transient Response

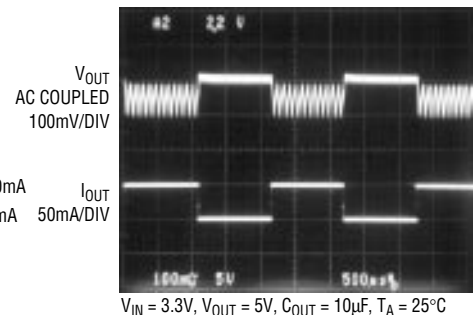

1515 G11

PIN FUNCTIONS

SHDN (Pin 1): Shutdown Input. A logic low on the $\overline{\text{SHDN}}$ pin puts the part into shutdown mode. A logic high ($V_{\overline{\text{SHDN}}} \geq 1.6\text{V}$) enables the part. At high V_{IN} voltages, the $\overline{\text{SHDN}}$ pin may still be controlled with 3V logic without causing a large rise in V_{IN} quiescent current. The $\overline{\text{SHDN}}$ pin may not float; connect to V_{IN} if unused.

POR (Pin 2): Open-Drain Power-On Reset Output. This pin will pull low upon initial power-up, during shutdown or until V_{OUT} has been within 6.5% of its regulated value for more than 200ms typ.

5/3 (LTC1515-X) (Pin 3): Output Voltage Select. A logic high on the 5/3 pin will force V_{OUT} to regulate to 5V. A logic

low will force V_{OUT} to 3V (LTC1515-3/5) or 3.3V (LTC1515-3.3/5). As with the $\overline{\text{SHDN}}$ pin, the 5/3 pin may be driven with 3V logic over the entire V_{IN} range. The 5/3 pin may not float.

FB (LTC1515) (Pin 3): Feedback Input. The voltage on this pin is compared to the internal reference voltage (1.232V) to keep the output in regulation. An external resistor divider is required between V_{OUT} and FB to adjust the output voltage. Total divider resistance should not exceed 2M.

GND (Pin 4): Ground. Should be tied to a ground plane for best performance.

C1⁻ (Pin 5): Charge Pump Flying Capacitor, Negative Terminal.

PIN FUNCTIONS

C1⁺ (Pin 6): Charge Pump Flying Capacitor, Positive Terminal.

V_{IN} (Pin 7): Charge Pump Input Voltage. May be between 2V and 10V. V_{IN} should be bypassed with a $\geq 10\mu\text{F}$ low ESR capacitor as close as possible to the pin for best performance.

V_{OUT} (Pin 8): Regulated Output Voltage. Pin selectable to either 3V/5V, 3.3V/5V or adjustable using an external resistor divider (LTC1515). V_{OUT} should be bypassed with a $\geq 10\mu\text{F}$ low ESR capacitor as close as possible to the pin for best performance.

SIMPLIFIED BLOCK DIAGRAM

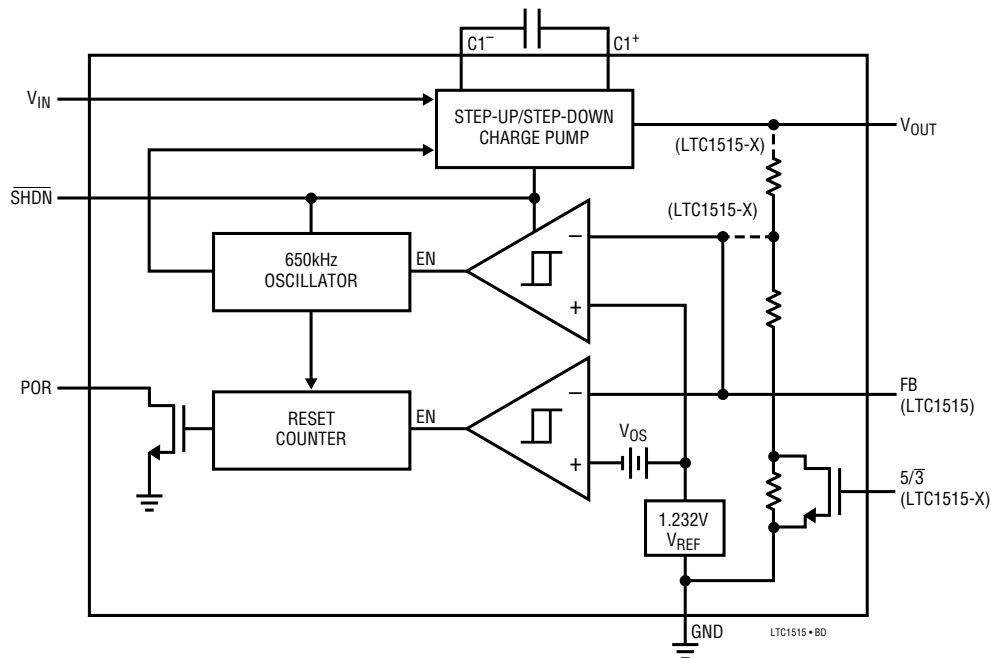

APPLICATIONS INFORMATION

Regulator Operation

The regulator section of the LTC1515, LTC1515-3/5 and LTC1515-3.3/5 consists of a charge pump, reference, comparator and some logic. The divided down output voltage is compared to the internal reference voltage. When the divided output drops below the reference voltage, the charge pump is enabled, which boosts the output back into regulation. Hysteresis in the comparator forces the regulator to burst on and off and causes approximately 100mV of peak-to-peak ripple to appear at the output. By enabling the charge pump only when needed, the parts achieve high efficiencies with low output load currents.

Each part's charge pump has a unique architecture that allows the input voltage to be either stepped up or stepped down to produce a regulated output. Internal circuitry senses the V_{IN} to V_{OUT} differential voltage and controls the charge pump operating mode. In addition, the effective output impedance of the charge pump is internally adjusted to prevent large inrush currents and allow for a wide input voltage range. When the input voltage is lower than the output voltage, the charge pump operates as a step-up voltage doubler. When the input voltage is greater than the output, the charge pump operates as a step-down gated switch.

APPLICATIONS INFORMATION

Output Voltage Selection

The LTC1515-X versions have internal resistor networks which set the output voltage. The 5/3 pin controls an internal switch that shorts out a portion of the resistor network to change the output voltage. A logic high on this pin produces a 5V output and a low produces either a 3V output or a 3.3V output.

The output voltage of the LTC1515 is selected using an external resistor divider (see Figure 1). The output voltage is determined using the following formula:

$$V_{OUT} = (1.232V)[1 + (R1/R2)]$$

The total resistance of R1 and R2 should not exceed 2M, otherwise excess ripple may appear at V_{OUT} .

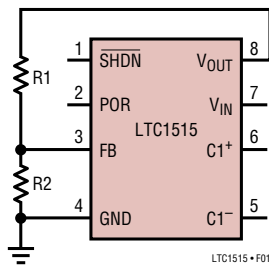

Figure 1. LTC1515 Output Voltage Selection

Maximum V_{OUT} and I_{OUT} Calculations for the LTC1515

The maximum output voltage and current available with the LTC1515 can be calculated based on the effective output resistance of the charge pump and the open circuit output voltage. In step-up mode, the open circuit output voltage is approximately $2V_{IN}$ (see Figure 2). In step-down mode, the open circuit output voltage equals V_{IN} . The relationship between R_{OUT} and V_{IN} in step-up mode is shown in Figure 3.

The following formulas can be used to find the maximum output voltage that may be programmed using the LTC1515 for a given minimum input voltage and output current load.

$$\text{Step-Up Mode: Max } V_{OUT} = (2)(\text{Min } V_{IN}) - (I_{OUT})(R_{OUT})$$

$$\text{Step-Down Mode: Max } V_{OUT} = (\text{Min } V_{IN}) - (I_{OUT})(R_{OUT})$$

When $V_{IN} - (I_{OUT})(R_{OUT})$ is less than the programmed V_{OUT} , the part will automatically switch from step-down mode to step-up mode. In both step-up mode and step-

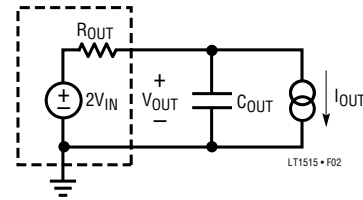

Figure 2. Step-Up Mode Equivalent Circuit

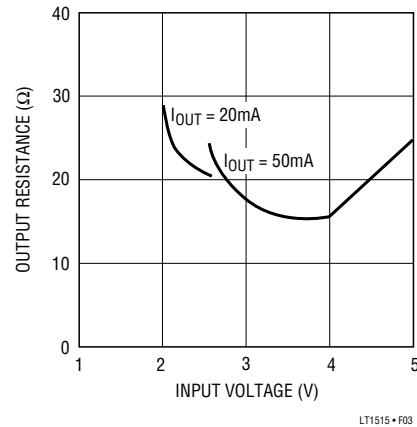

Figure 3. Step-Up Mode R_{OUT} vs Input Voltage

down mode, R_{OUT} is internally adjusted to ensure that the maximum output current rating can be met.

Capacitor Selection

For best performance, low ESR capacitors are recommended for both C_{IN} and C_{OUT} to reduce noise and ripple. The C_{IN} and C_{OUT} capacitors should be either ceramic or tantalum and should be $10\mu\text{F}$ or greater. If the input source impedance is very low ($< 0.5\Omega$) C_{IN} may not be needed. Increasing the size of C_{OUT} to $22\mu\text{F}$ or greater will reduce output voltage ripple — particularly with high V_{IN} voltages (8V or greater). A ceramic capacitor is recommended for the flying capacitor C1 with a value of $0.1\mu\text{F}$ or $0.22\mu\text{F}$. Smaller values may be used in low output current applications.

Output Ripple

Normal LTC1515 series operation produces voltage ripple on the V_{OUT} pin. Output voltage ripple is required for the parts to regulate. Low frequency ripple exists due to the hysteresis in the sense comparator and propagation delays in the charge pump enable/disable circuits. High frequency ripple is also present mainly from the ESR

APPLICATIONS INFORMATION

(equivalent series resistance) in the output capacitor. Typical output ripple ($V_{IN} < 8V$) under maximum load is 100mV peak-to-peak with a low ESR, 10 μ F output capacitor. For applications requiring V_{IN} to exceed 8V, a 22 μ F or larger C_{OUT} capacitor is recommended to maintain maximum ripple in the 100mV range.

The magnitude of the ripple voltage depends on several factors. High input voltages increase the output ripple since more charge is delivered to C_{OUT} per charging cycle. A large C1 flying capacitor ($> 0.22\mu$ F) also increases ripple in step-up mode for the same reason. Large output current load and/or a small output capacitor ($< 10\mu$ F) results in higher ripple due to higher output voltage dV/dt . High ESR capacitors ($ESR > 0.5\Omega$) on the output pin cause high frequency voltage spikes on V_{OUT} with every clock cycle.

There are several ways to reduce the output voltage ripple. A large C_{OUT} capacitor (22 μ F or greater) will reduce both the low and high frequency ripple due to the lower C_{OUT} charging and discharging dV/dt and the lower ESR typically found with higher value (larger case size) capacitors. A low ESR ($< 0.5\Omega$) ceramic output capacitor will minimize the high frequency ripple, but will not reduce the low frequency ripple unless a high capacitance value is chosen. A reasonable compromise is to use a 10 μ F to 22 μ F tantalum capacitor in parallel with a 1 μ F to 3.3 μ F ceramic capacitor on V_{OUT} to reduce both the low and high frequency ripple. An RC or LC filter may also be used to reduce high frequency voltage spikes (see Figure 4).

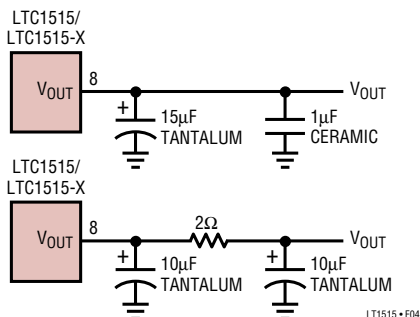

Figure 4. Output Ripple Reduction Techniques

Inrush Currents

A common problem with switched capacitor regulators is inrush current—particularly during power-up and com-

ing out of shutdown mode. Whenever large V_{IN} (or boosted V_{IN}) to V_{OUT} voltage differentials are present, most charge pumps will pull large current spikes from the input supply. Only the effective charge pump output impedance limits the current while the charge pump is enabled. This may disrupt input supply regulation, especially if the input supply is a low power DC/DC converter or linear regulator. The LTC1515 family minimizes inrush currents both at start-up and under high V_{IN} to V_{OUT} operation.

Internal soft start circuitry controls the rate at which V_{OUT} may be charged from 0V to its final regulated value. The typical start-up time from $V_{OUT} = 0V$ to 5V is 4ms. This corresponds to an effective V_{OUT} charging current of only 12.5mA for a 10 μ F output capacitor (27.5mA for 22 μ F, etc.). Note that any output current load present during start-up will add directly to the charging currents mentioned above. The soft start circuitry limits start-up current both at initial power-up and when coming out of shutdown.

As the V_{IN} (or boosted V_{IN}) to V_{OUT} voltage differential grows, the effective output impedance of the charge pump is automatically increased by internal voltage sensing circuitry. This feature minimizes the current spikes pulled from V_{IN} whenever the charge pump is enabled and helps to reduce both input and output ripple.

Power-On Reset

The POR pin is an open-drain output that pulls low when the output voltage is out of regulation. When the V_{OUT} rises to within 6.5% of regulation, an internal timer is started which releases POR after 200ms (typ). In shutdown, the POR output is pulled low. In normal operation, an external pull-up resistor is generally used between the POR pin and V_{OUT} .

Protection Features

All of the parts contain thermal shutdown and short-circuit protection features. The parts will shut down when the junction temperature reaches approximately 150°C and will resume operation once the junction temperature has dropped back to approximately 140°C. The parts will limit output current to 12mA (typ) when a short circuit condition ($V_{OUT} < 100mV$) exists. The parts can survive an indefinite short to GND.

TYPICAL APPLICATIONS

Low Power, Low Noise Step-Up/Step-Down 5V Supply with Reset

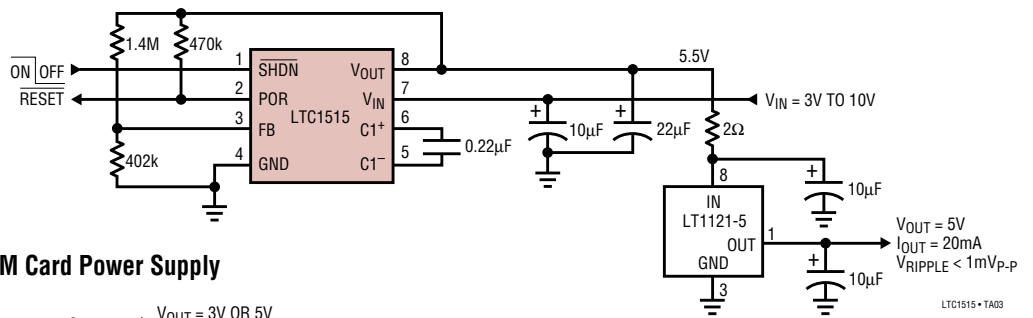

Programmable 3V/5V GSM SIM Card Power Supply

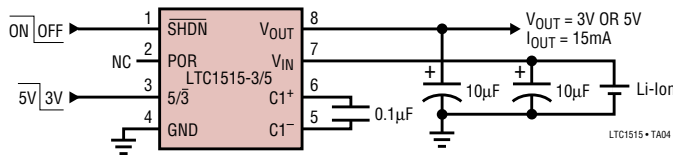

Positive and Negative Supply

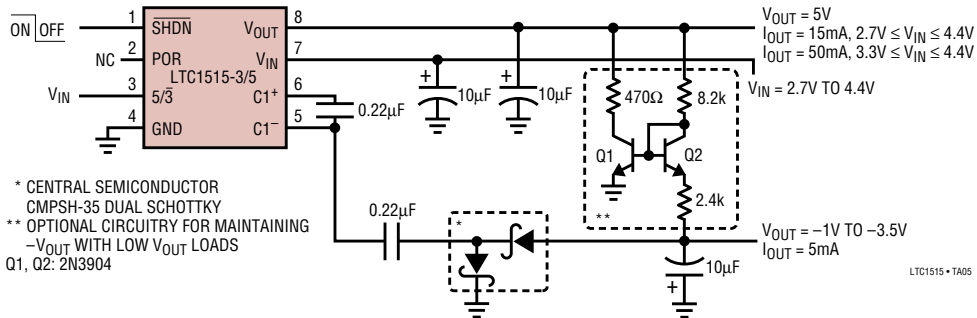

PACKAGE DESCRIPTION

Dimensions in inches (millimeters) unless otherwise noted.

S8 Package 8-Lead Plastic Small Outline (Narrow 0.150) (LTC DWG # 05-08-1610)

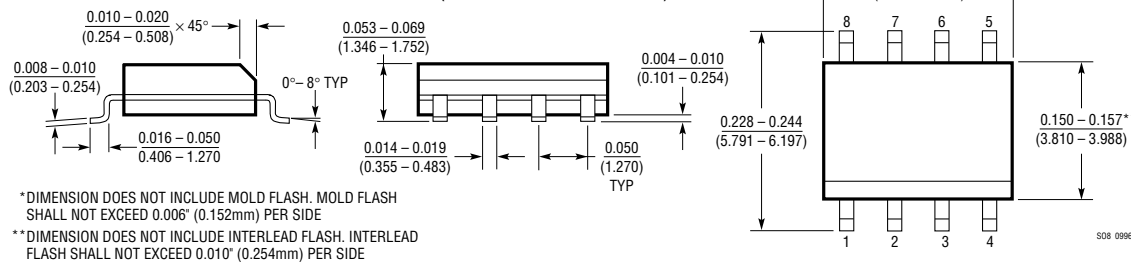

RELATED PARTS

PART NUMBER	DESCRIPTION	COMMENTS
LTC1514 Series	Step-Up/Step-Down Switched Capacitor DC/DC Converters	V _{IN} 2V to 10V, 3.3V and 5V Versions, I _{OUT} to 50mA
LTC1516	Micropower, Regulated 5V Charge Pump DC/DC Converter	I _{OUT} = 20mA (V _{IN} ≥ 2V), I _{OUT} = 50mA (V _{IN} ≥ 3V)
LTC1517-5	Micropower, Regulated 5V Charge Pump DC/DC Converter	LTC1522 Without Shutdown and Packaged in SOT-23
LTC1522	Micropower, Regulated 5V Charge Pump DC/DC Converter	Available in 8-Pin MSOP, 6μA Quiescent Current, I _{OUT} = 20mA
LTC1555/LTC1556	SIM Power Supply and Level Translators	Step-Up/Step-Down SIM Power Supply and Level Translators
LTC660	100mA CMOS Voltage Converter	5V to -5V Conversion with Low Voltage Loss