

## FEATURES

- 500ksps Throughput Rate
- $\pm 0.5\text{LSB}$  INL (Max)
- Guaranteed 16-Bit No Missing Codes
- Low Power: 6.8mW at 500ksps, 6.8 $\mu\text{W}$  at 500sps
- 97dB SNR (Typ) at  $f_{\text{IN}} = 2\text{kHz}$
- $-123\text{dB}$  THD (Typ) at  $f_{\text{IN}} = 2\text{kHz}$
- Digital Gain Compression (DGC)
- Guaranteed Operation to 125°C
- 2.5V Supply
- Fully Differential Input Range  $\pm V_{\text{REF}}$
- $V_{\text{REF}}$  Input Range from 2.5V to 5.1V
- No Pipeline Delay, No Cycle Latency
- 1.8V to 5V I/O Voltages
- SPI-Compatible Serial I/O with Daisy-Chain Mode
- Internal Conversion Clock
- 16-Lead MSOP and 4mm  $\times$  3mm DFN Packages

## APPLICATIONS

- Medical Imaging
- High Speed Data Acquisition
- Portable or Compact Instrumentation
- Industrial Process Control
- Low Power Battery-Operated Instrumentation
- ATE

LT, LT, LTC, LTM, Linear Technology and the Linear logo are registered trademarks and SoftSpan is a trademark of Linear Technology Corporation. All other trademarks are the property of their respective owners.

## DESCRIPTION

The LTC<sup>®</sup>2377-16 is a low noise, low power, high speed 16-bit successive approximation register (SAR) ADC. Operating from a 2.5V supply, the LTC2377-16 has a  $\pm V_{\text{REF}}$  fully differential input range with  $V_{\text{REF}}$  ranging from 2.5V to 5.1V. The LTC2377-16 consumes only 6.8mW and achieves  $\pm 0.5\text{LSB}$  INL maximum, no missing codes at 16 bits with 97dB SNR.

The LTC2377-16 has a high speed SPI-compatible serial interface that supports 1.8V, 2.5V, 3.3V and 5V logic while also featuring a daisy-chain mode. The fast 500ksps throughput with no cycle latency makes the LTC2377-16 ideally suited for a wide variety of high speed applications. An internal oscillator sets the conversion time, easing external timing considerations. The LTC2377-16 automatically powers down between conversions, leading to reduced power dissipation that scales with the sampling rate.

The LTC2377-16 features a unique digital gain compression (DGC) function, which eliminates the driver amplifier's negative supply while preserving the full resolution of the ADC. When enabled, the ADC performs a digital scaling function that maps zero-scale code from 0V to  $0.1 \cdot V_{\text{REF}}$  and full-scale code from  $V_{\text{REF}}$  to  $0.9 \cdot V_{\text{REF}}$ . For a typical reference voltage of 5V, the full-scale input range is now 0.5V to 4.5V, which provides adequate headroom for powering the driving amplifier from a single 5.5V supply.

## TYPICAL APPLICATION

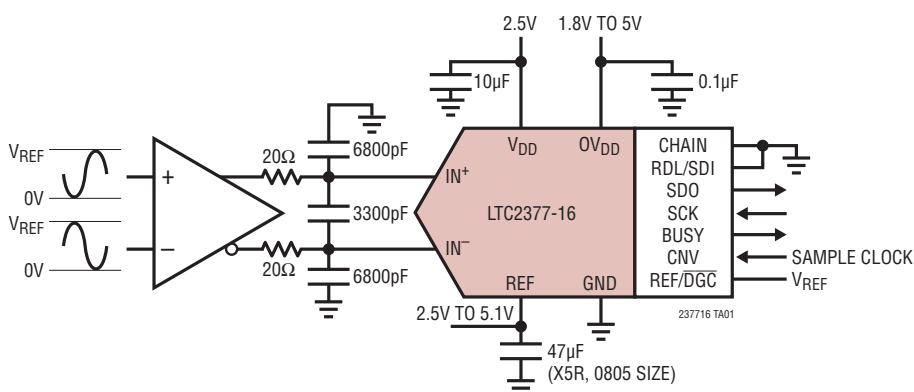

32k Point FFT  $f_s = 500\text{ksps}$ ,  $f_{\text{IN}} = 2\text{kHz}$

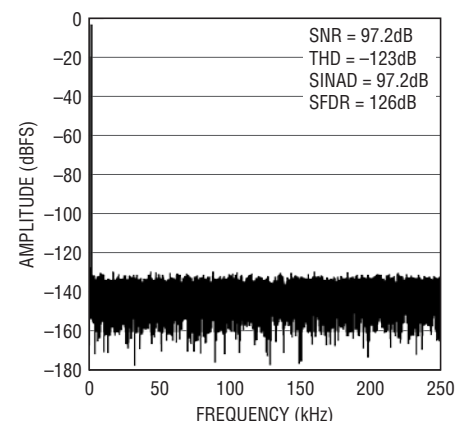

237716 TA02  
237716f

## ABSOLUTE MAXIMUM RATINGS

(Notes 1, 2)

Supply Voltage ( $V_{DD}$ ) .....	2.8V	Digital Output Voltage	
Supply Voltage ( $OV_{DD}$ ) .....	6V	(Note 3) .....	(GND - 0.3V) to ( $OV_{DD} + 0.3V$ )
Reference Input (REF) .....	6V	Power Dissipation .....	500mW
Analog Input Voltage (Note 3)		Operating Temperature Range	
$IN^+$ , $IN^-$ .....	(GND - 0.3V) to (REF + 0.3V)	LTC2377C .....	0°C to 70°C
REF/DGC Input (Note 3) ....	(GND - 0.3V) to (REF + 0.3V)	LTC2377I .....	-40°C to 85°C
Digital Input Voltage		LTC2377H .....	-40°C to 125°C
(Note 3) .....	(GND - 0.3V) to ( $OV_{DD} + 0.3V$ )	Storage Temperature Range .....	-65°C to 150°C

## PIN CONFIGURATION

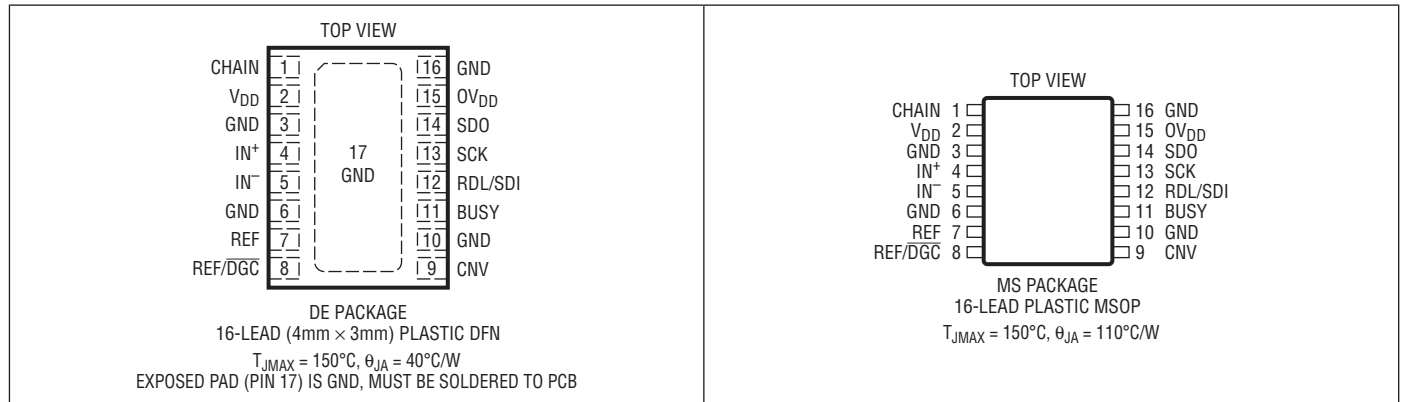

## ORDER INFORMATION

LEAD FREE FINISH	TAPE AND REEL	PART MARKING*	PACKAGE DESCRIPTION	TEMPERATURE RANGE
LTC2377CMS-16#PBF	LTC2377CMS-16#TRPBF	237716	16-Lead Plastic MSOP	0°C to 70°C
LTC2377IMS-16#PBF	LTC2377IMS-16#TRPBF	237716	16-Lead Plastic MSOP	-40°C to 85°C
LTC2377HMS-16#PBF	LTC2377HMS-16#TRPBF	237716	16-Lead Plastic MSOP	-40°C to 125°C
LTC2377CDE-16#PBF	LTC2377CDE-16#TRPBF	23776	16-Lead (4mm × 3mm) Plastic DFN	0°C to 70°C
LTC2377IDE-16#PBF	LTC2377IDE-16#TRPBF	23776	16-Lead (4mm × 3mm) Plastic DFN	-40°C to 85°C

Consult LTC Marketing for parts specified with wider operating temperature ranges. \*The temperature grade is identified by a label on the shipping container. Consult LTC Marketing for information on non-standard lead based finish parts.

For more information on lead free part marking, go to: <http://www.linear.com/leadfree/>

For more information on tape and reel specifications, go to: <http://www.linear.com/tapeandreeel/>

## ELECTRICAL CHARACTERISTICS

The ● denotes the specifications which apply over the full operating temperature range, otherwise specifications are at  $T_A = 25^\circ\text{C}$ . (Note 4)

SYMBOL	PARAMETER	CONDITIONS	MIN	TYP	MAX	UNITS
$V_{IN+}$	Absolute Input Range ( $IN^+$ )	(Note 5)	●	-0.05	$V_{REF} + 0.05$	V
$V_{IN-}$	Absolute Input Range ( $IN^-$ )	(Note 5)	●	-0.05	$V_{REF} + 0.05$	V
$V_{IN+} - V_{IN-}$	Input Differential Voltage Range	$V_{IN} = V_{IN+} - V_{IN-}$	●	$-V_{REF}$	$+V_{REF}$	V
$V_{CM}$	Common-Mode Input Range		●	$V_{REF}/2 - 0.1$	$V_{REF}/2 + 0.1$	V
$I_{IN}$	Analog Input Leakage Current		●		$\pm 1$	$\mu\text{A}$
$C_{IN}$	Analog Input Capacitance	Sample Mode Hold Mode		45 5		pF pF
CMRR	Input Common Mode Rejection Ratio	$f_{IN} = 250\text{kHz}$		86		dB

## CONVERTER CHARACTERISTICS

The ● denotes the specifications which apply over the full operating temperature range, otherwise specifications are at  $T_A = 25^\circ\text{C}$ . (Note 4)

SYMBOL	PARAMETER	CONDITIONS	MIN	TYP	MAX	UNITS
	Resolution		●	16		Bits
	No Missing Codes		●	16		Bits
	Transition Noise			0.15		$\text{LSB}_{\text{RMS}}$
INL	Integral Linearity Error	(Note 6)	●	-0.5	$\pm 0.2$	0.5 LSB
DNL	Differential Linearity Error		●	-0.5	$\pm 0.1$	0.5 LSB
BZE	Bipolar Zero-Scale Error	(Note 7)	●	-4	0	4 LSB
	Bipolar Zero-Scale Error Drift			1		$\text{mLSB}/^\circ\text{C}$
FSE	Bipolar Full-Scale Error	(Note 7)	●	-13	$\pm 2$	13 LSB
	Bipolar Full-Scale Error Drift			$\pm 0.05$		$\text{ppm}/^\circ\text{C}$

## DYNAMIC ACCURACY

The ● denotes the specifications which apply over the full operating temperature range, otherwise specifications are at  $T_A = 25^\circ\text{C}$  and  $A_{IN} = -1\text{dBFS}$ . (Notes 4, 8)

SYMBOL	PARAMETER	CONDITIONS	MIN	TYP	MAX	UNITS
SINAD	Signal-to-(Noise + Distortion) Ratio	$f_{IN} = 2\text{kHz}$ , $V_{REF} = 5\text{V}$	●	94.6	97	dB
		$f_{IN} = 2\text{kHz}$ , $V_{REF} = 5\text{V}$ , (H-Grade)	●	94.5	97	dB
SNR	Signal-to-Noise Ratio	$f_{IN} = 2\text{kHz}$ , $V_{REF} = 5\text{V}$	●	95.3	97	dB
		$f_{IN} = 2\text{kHz}$ , $V_{REF} = 5\text{V}$ , $\text{REF}/\overline{\text{DGC}} = \text{GND}$	●	94.5	96.4	dB
		$f_{IN} = 2\text{kHz}$ , $V_{REF} = 2.5\text{V}$	●	92.1	95	dB
		$f_{IN} = 2\text{kHz}$ , $V_{REF} = 5\text{V}$ , (H-Grade)	●	95.2	97	dB
		$f_{IN} = 2\text{kHz}$ , $V_{REF} = 5\text{V}$ , $\text{REF}/\overline{\text{DGC}} = \text{GND}$ , (H-Grade)	●	94.3	96.4	dB
		$f_{IN} = 2\text{kHz}$ , $V_{REF} = 2.5\text{V}$ , (H-Grade)	●	91.8	95	dB
THD	Total Harmonic Distortion	$f_{IN} = 2\text{kHz}$ , $V_{REF} = 5\text{V}$	●	-123	-103	dB
		$f_{IN} = 2\text{kHz}$ , $V_{REF} = 5\text{V}$ , $\text{REF}/\overline{\text{DGC}} = \text{GND}$	●	-125	-101	dB
		$f_{IN} = 2\text{kHz}$ , $V_{REF} = 2.5\text{V}$	●	-122	-103	dB
SFDR	Spurious Free Dynamic Range	$f_{IN} = 2\text{kHz}$ , $V_{REF} = 5\text{V}$	●	104	124	dB
		-3dB Input Bandwidth			34	MHz
	Aperture Delay			500	ps	
	Aperture Jitter			4	ps	
	Transient Response	Full-Scale Step			1.46	$\mu\text{s}$

## REFERENCE INPUT

The ● denotes the specifications which apply over the full operating temperature range, otherwise specifications are at  $T_A = 25^\circ\text{C}$ . (Note 4)

SYMBOL	PARAMETER	CONDITIONS	MIN	TYP	MAX	UNITS
$V_{REF}$	Reference Voltage	(Note 5)	● 2.5		5.1	V
$I_{REF}$	Reference Input Current	(Note 9)	●	0.32	0.4	mA
$V_{IH\overline{DGC}}$	High Level Input Voltage REF/ $\overline{DGC}$ Pin		● 0.8 $V_{REF}$			V
$V_{IL\overline{DGC}}$	Low Level Input Voltage REF/ $\overline{DGC}$ Pin		●		0.2 $V_{REF}$	V

## DIGITAL INPUTS AND DIGITAL OUTPUTS

The ● denotes the specifications which apply over the full operating temperature range, otherwise specifications are at  $T_A = 25^\circ\text{C}$ . (Note 4)

SYMBOL	PARAMETER	CONDITIONS	MIN	TYP	MAX	UNITS
$V_{IH}$	High Level Input Voltage		● 0.8 • $OV_{DD}$			V
$V_{IL}$	Low Level Input Voltage		●		0.2 • $OV_{DD}$	V
$I_{IN}$	Digital Input Current	$V_{IN} = 0V$ to $OV_{DD}$	● -10		10	$\mu\text{A}$
$C_{IN}$	Digital Input Capacitance			5		pF
$V_{OH}$	High Level Output Voltage	$I_O = -500\mu\text{A}$	● $OV_{DD} - 0.2$			V
$V_{OL}$	Low Level Output Voltage	$I_O = 500\mu\text{A}$	●		0.2	V
$I_{OZ}$	Hi-Z Output Leakage Current	$V_{OUT} = 0V$ to $OV_{DD}$	● -10		10	$\mu\text{A}$
$I_{SOURCE}$	Output Source Current	$V_{OUT} = 0V$		-10		mA
$I_{SINK}$	Output Sink Current	$V_{OUT} = OV_{DD}$		10		mA

## POWER REQUIREMENTS

The ● denotes the specifications which apply over the full operating temperature range, otherwise specifications are at  $T_A = 25^\circ\text{C}$ . (Note 4)

SYMBOL	PARAMETER	CONDITIONS	MIN	TYP	MAX	UNITS
$V_{DD}$	Supply Voltage		● 2.375	2.5	2.625	V
$OV_{DD}$	Supply Voltage		● 1.71		5.25	V
$I_{VDD}$	Supply Current	500ksps Sample Rate	●	2.7	3.2	mA
$I_{OVDD}$	Supply Current	500ksps Sample Rate ( $C_L = 20\text{pF}$ )	●	0.1		mA
$I_{PD}$	Power Down Mode	Conversion Done ( $I_{VDD} + I_{OVDD} + I_{REF}$ )	●	0.9	90	$\mu\text{A}$
$I_{PD}$	Power Down Mode	Conversion Done ( $I_{VDD} + I_{OVDD} + I_{REF}$ , H-Grade)	●	0.9	140	$\mu\text{A}$
$P_D$	Power Dissipation	500ksps Sample Rate		6.75	8	mW
	Power Down Mode	Conversion Done ( $I_{VDD} + I_{OVDD} + I_{REF}$ )		2.25	225	$\mu\text{W}$
	Power Down Mode	Conversion Done ( $I_{VDD} + I_{OVDD} + I_{REF}$ , H-Grade)		2.25	315	$\mu\text{W}$

## ADC TIMING CHARACTERISTICS

The ● denotes the specifications which apply over the full operating temperature range, otherwise specifications are at  $T_A = 25^\circ\text{C}$ . (Note 4)

SYMBOL	PARAMETER	CONDITIONS	MIN	TYP	MAX	UNITS
$f_{SAMPL}$	Maximum Sampling Frequency		●		500	ksps
$t_{CONV}$	Conversion Time		● 1		1.5	$\mu\text{s}$
$t_{ACQ}$	Acquisition Time	$t_{ACQ} = t_{CYC} - t_{HOLD}$ (Note 10)	● 1.46			$\mu\text{s}$
$t_{HOLD}$	Maximum Time Between Acquisitions		●		540	ns
$t_{CYC}$	Time Between Conversions		● 2			$\mu\text{s}$
$t_{CNVH}$	CNV High Time		● 20			ns
$t_{BUSY\overline{LH}}$	CNV $\uparrow$ to BUSY Delay	$C_L = 20\text{pF}$	●		13	ns
$t_{CNVL}$	Minimum Low Time for CNV	(Note 11)	● 20			ns
$t_{QUIET}$	SCK Quiet Time from CNV $\uparrow$	(Note 10)	● 20			ns

## ADC TIMING CHARACTERISTICS

The ● denotes the specifications which apply over the full operating temperature range, otherwise specifications are at  $T_A = 25^\circ\text{C}$ . (Note 4)

SYMBOL	PARAMETER	CONDITIONS	MIN	TYP	MAX	UNITS
$t_{\text{SCK}}$	SCK Period	(Notes 11, 12)	●	10		ns
$t_{\text{SCKH}}$	SCK High Time		●	4		ns
$t_{\text{SCKL}}$	SCK Low Time		●	4		ns
$t_{\text{SSDISCK}}$	SDI Setup Time From SCK↑	(Note 11)	●	4		ns
$t_{\text{HSDISCK}}$	SDI Hold Time From SCK↑	(Note 11)	●	1		ns
$t_{\text{SCKCH}}$	SCK Period in Chain Mode	$t_{\text{SCKCH}} = t_{\text{SSDISCK}} + t_{\text{DSDO}}$ (Note 11)	●	13.5		ns
$t_{\text{DSDO}}$	SDO Data Valid Delay from SCK↑	$C_L = 20\text{pF}$ (Note 11)	●		9.5	ns
$t_{\text{HSDO}}$	SDO Data Remains Valid Delay from SCK↑	$C_L = 20\text{pF}$ (Note 10)	●	1		ns
$t_{\text{DSDOBUSYL}}$	SDO Data Valid Delay from BUSY↓	$C_L = 20\text{pF}$ (Note 10)	●		5	ns
$t_{\text{EN}}$	Bus Enable Time After RDL↓	(Note 11)	●		16	ns
$t_{\text{DIS}}$	Bus Relinquish Time After RDL↑	(Note 11)	●		13	ns

**Note 1:** Stresses beyond those listed under Absolute Maximum Ratings may cause permanent damage to the device. Exposure to any Absolute Maximum Rating condition for extended periods may effect device reliability and lifetime.

**Note 2:** All voltage values are with respect to ground.

**Note 3:** When these pin voltages are taken below ground or above  $\text{REF}$  or  $\text{OV}_{\text{DD}}$ , they will be clamped by internal diodes. This product can handle input currents up to 100mA below ground or above  $\text{REF}$  or  $\text{OV}_{\text{DD}}$  without latch-up.

**Note 4:**  $V_{\text{DD}} = 2.5\text{V}$ ,  $\text{OV}_{\text{DD}} = 2.5\text{V}$ ,  $\text{REF} = 5\text{V}$ ,  $V_{\text{CM}} = 2.5\text{V}$ ,  $f_{\text{SMPL}} = 500\text{kHz}$ ,  $\text{REF}/\text{DGC} = V_{\text{REF}}$ .

**Note 5:** Recommended operating conditions.

**Note 6:** Integral nonlinearity is defined as the deviation of a code from a straight line passing through the actual endpoints of the transfer curve. The deviation is measured from the center of the quantization band.

**Note 7:** Bipolar zero-scale error is the offset voltage measured from  $-0.5\text{LSB}$  when the output code flickers between 0000 0000 0000 0000 and 1111 1111 1111 1111. Full-scale bipolar error is the worst-case of  $-\text{FS}$  or  $+\text{FS}$  untrimmed deviation from ideal first and last code transitions and includes the effect of offset error.

**Note 8:** All specifications in dB are referred to a full-scale  $\pm 5\text{V}$  input with a 5V reference voltage.

**Note 9:**  $f_{\text{SMPL}} = 500\text{kHz}$ ,  $I_{\text{REF}}$  varies proportionately with sample rate.

**Note 10:** Guaranteed by design, not subject to test.

**Note 11:** Parameter tested and guaranteed at  $\text{OV}_{\text{DD}} = 1.71\text{V}$ ,  $\text{OV}_{\text{DD}} = 2.5\text{V}$  and  $\text{OV}_{\text{DD}} = 5.25\text{V}$ .

**Note 12:**  $t_{\text{SCK}}$  of 10ns maximum allows a shift clock frequency up to 100MHz for rising capture.

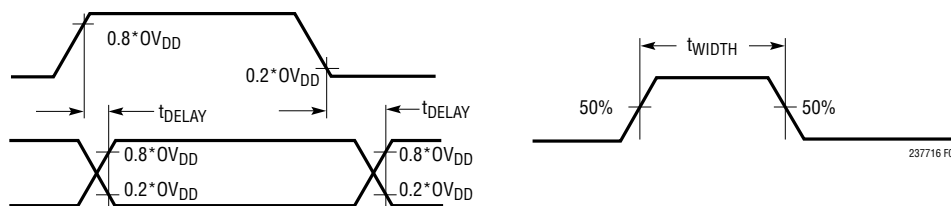
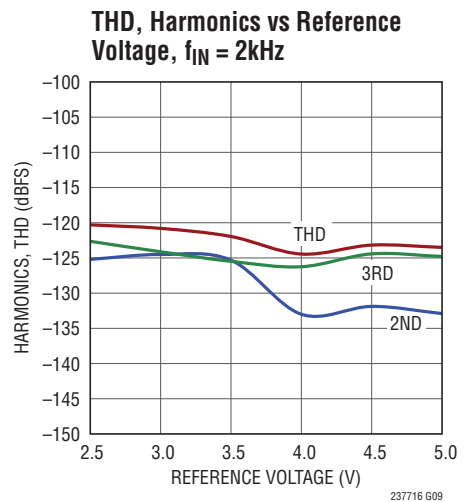
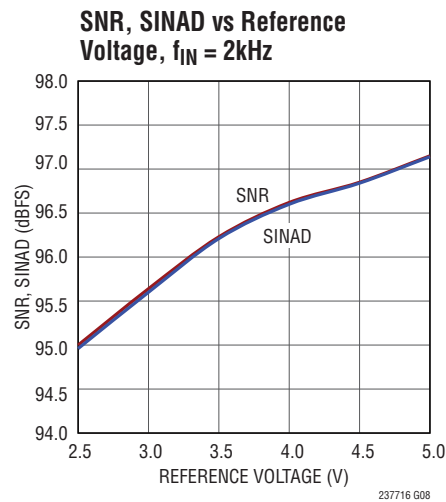
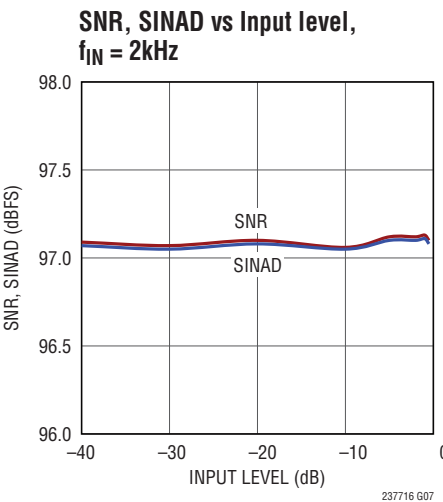
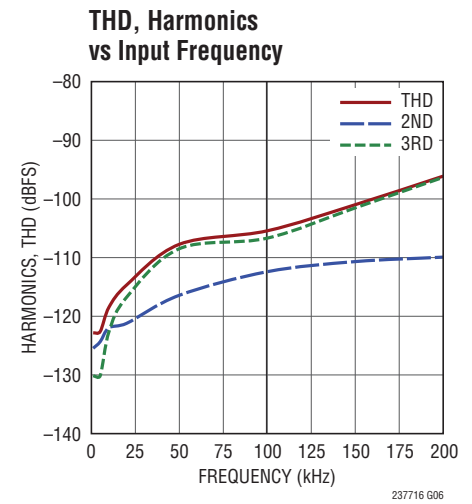
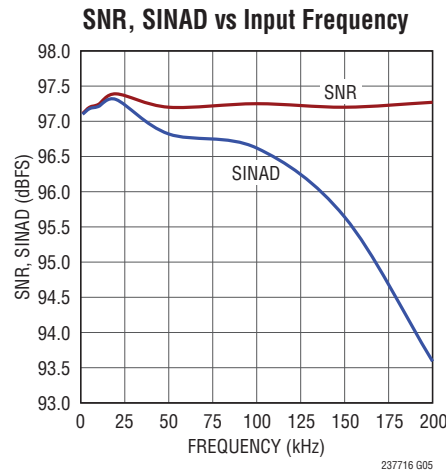
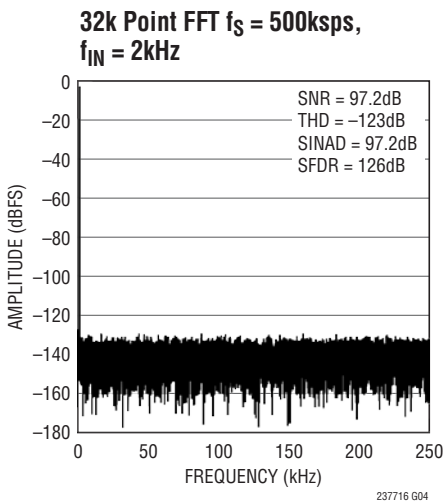
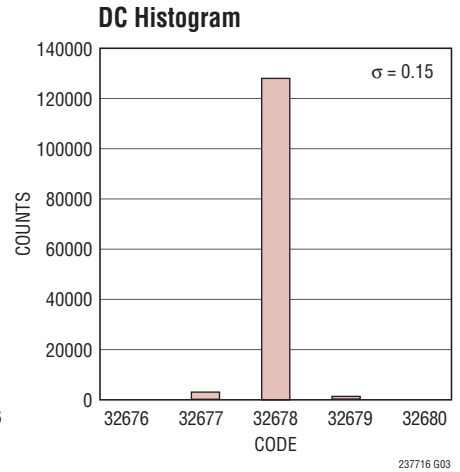
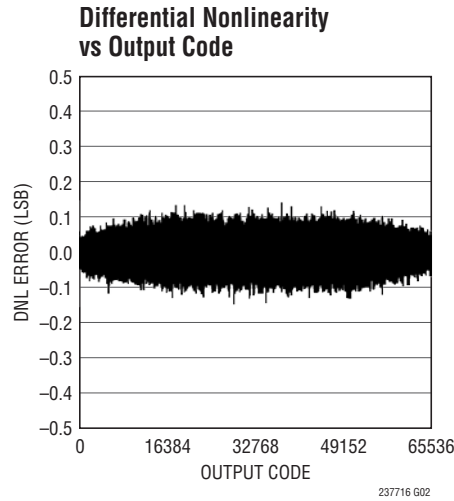
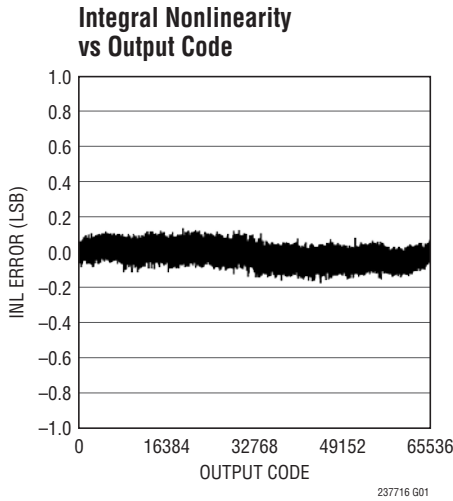

Figure 1. Voltage Levels for Timing Specifications

**TYPICAL PERFORMANCE CHARACTERISTICS**

REF = 5V,  $f_{SAMPL} = 500\text{kps}$ , unless otherwise noted.

$T_A = 25^\circ\text{C}$ ,  $V_{DD} = 2.5\text{V}$ ,  $0V_{DD} = 2.5\text{V}$ ,  $V_{CM} = 2.5\text{V}$ ,



**TYPICAL PERFORMANCE CHARACTERISTICS**  $T_A = 25^\circ\text{C}$ ,  $V_{DD} = 2.5\text{V}$ ,  $OV_{DD} = 2.5\text{V}$ ,  $V_{CM} = 2.5\text{V}$ ,  
 $REF = 5\text{V}$ ,  $f_{SAMPL} = 500\text{ksps}$ , unless otherwise noted.

**SNR, SINAD vs Temperature,**  
 $f_{IN} = 2\text{kHz}$

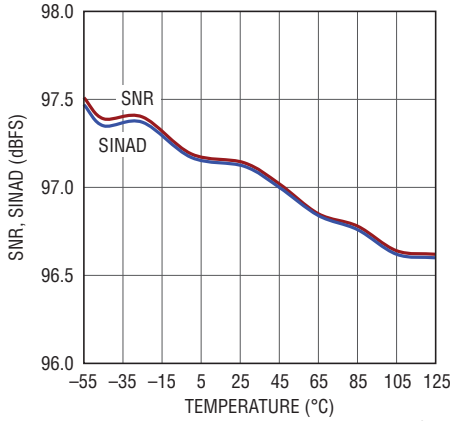

237716 G10

**THD, Harmonics vs Temperature,**  
 $f_{IN} = 2\text{kHz}$

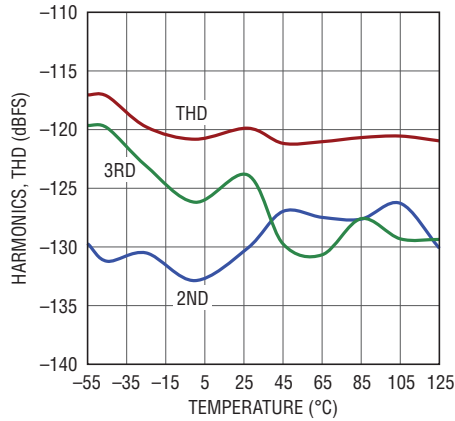

237716 G11

**INL/DNL vs Temperature**

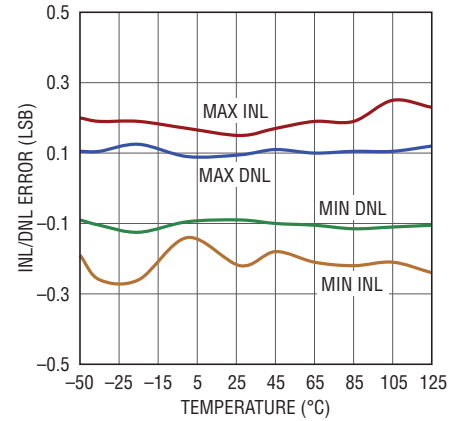

237716 G12

**Full-Scale Error vs Temperature**

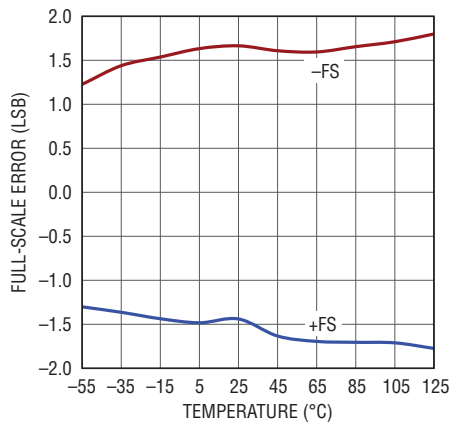

237716 G13

**Offset Error vs Temperature**

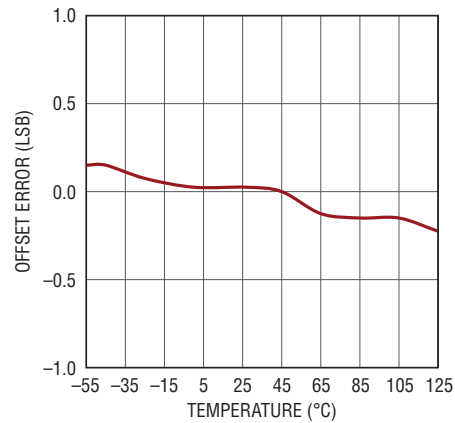

237716 G14

**Supply Current vs Temperature**

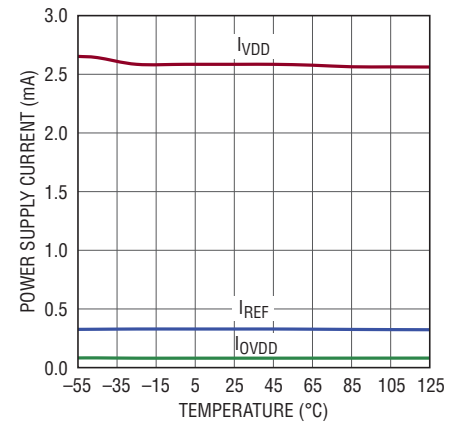

237716 G15

**Shutdown Current vs Temperature**

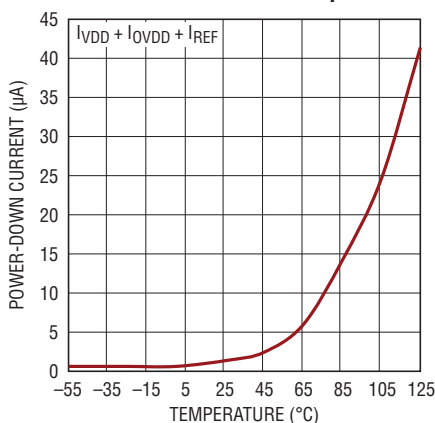

237716 G16

**CMRR vs Input Frequency**

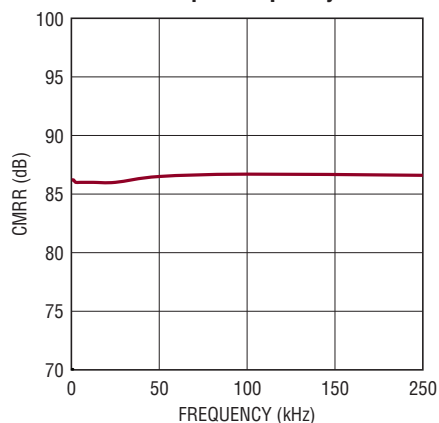

237716 G17

**Reference Current vs Reference Voltage**

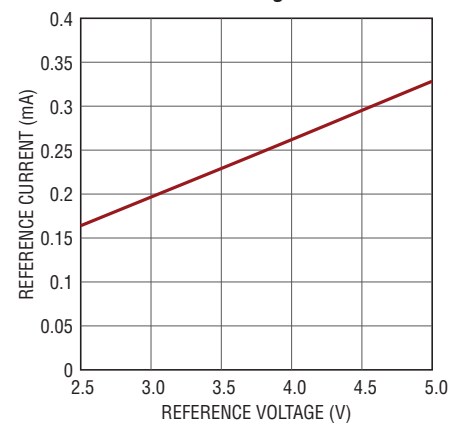

237716 G18



## PIN FUNCTIONS

**CHAIN (Pin 1):** Chain Mode Selector Pin. When low, the LTC2377-16 operates in normal mode and the RDL/SDI input pin functions to enable or disable SDO. When high, the LTC2377-16 operates in chain mode and the RDL/SDI pin functions as SDI, the daisy-chain serial data input. Logic levels are determined by  $OV_{DD}$ .

**$V_{DD}$  (Pin 2):** 2.5V Power Supply. The range of  $V_{DD}$  is 2.375V to 2.625V. Bypass  $V_{DD}$  to GND with a 10 $\mu$ F ceramic capacitor.

**GND (Pins 3, 6, 10 and 16):** Ground.

**$IN^+$ ,  $IN^-$  (Pins 4, 5):** Positive and Negative Differential Analog Inputs.

**REF (Pin 7):** Reference Input. The range of REF is 2.5V to 5.1V. This pin is referred to the GND pin and should be decoupled closely to the pin with a 47 $\mu$ F ceramic capacitor (X5R, 0805 size).

**REF/DGC (Pin 8):** When tied to REF, digital gain compression is disabled and the LTC2377-16 defines full-scale according to the  $\pm V_{REF}$  analog input range. When tied to GND, digital gain compression is enabled and the LTC2377-16 defines full-scale with inputs that swing between 10% and 90% of the  $\pm V_{REF}$  analog input range.

**CNV (Pin 9):** Convert Input. A rising edge on this input powers up the part and initiates a new conversion. Logic levels are determined by  $OV_{DD}$ .

**BUSY (Pin 11):** BUSY Indicator. Goes high at the start of a new conversion and returns low when the conversion has finished. Logic levels are determined by  $OV_{DD}$ .

**RDL/SDI (Pin 12):** When CHAIN is low, the part is in normal mode and the pin is treated as a bus enabling input. When CHAIN is high, the part is in chain mode and the pin is treated as a serial data input pin where data from another ADC in the daisy-chain is input. Logic levels are determined by  $OV_{DD}$ .

**SCK (Pin 13):** Serial Data Clock Input. When SDO is enabled, the conversion result or daisy-chain data from another ADC is shifted out on the rising edges of this clock MSB first. Logic levels are determined by  $OV_{DD}$ .

**SDO (Pin 14):** Serial Data Output. The conversion result or daisy-chain data is output on this pin on each rising edge of SCK MSB first. The output data is in 2's complement format. Logic levels are determined by  $OV_{DD}$ .

**$OV_{DD}$  (Pin 15):** I/O Interface Digital Power. The range of  $OV_{DD}$  is 1.71V to 5.25V. This supply is nominally set to the same supply as the host interface (1.8V, 2.5V, 3.3V, or 5V). Bypass  $OV_{DD}$  to GND with a 0.1 $\mu$ F capacitor.

**GND (Exposed Pad Pin 17 – DFN Package Only):** Ground. Exposed pad must be soldered directly to the ground plane.

## FUNCTIONAL BLOCK DIAGRAM

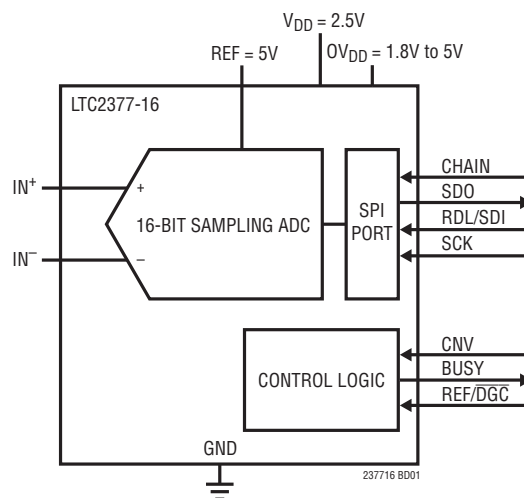

237716f



# TIMING DIAGRAM

### Conversion Timing Using the Serial Interface

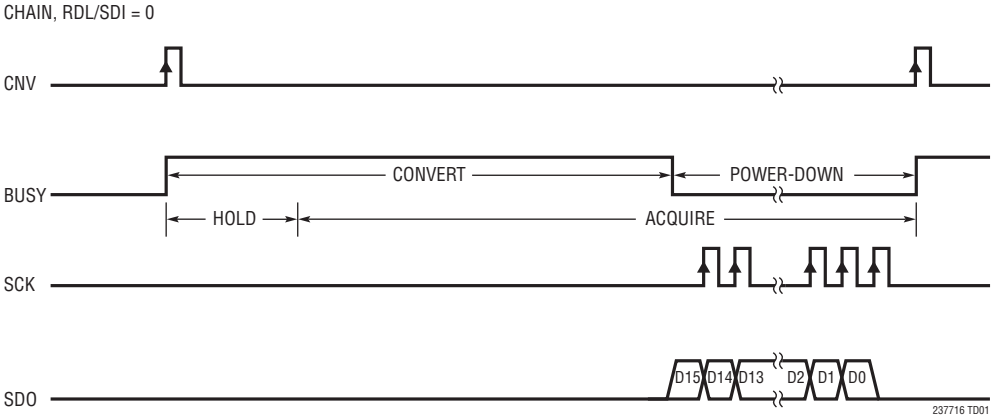

## APPLICATIONS INFORMATION

### OVERVIEW

The LTC2377-16 is a low noise, low power, high speed 16-Bit successive approximation register (SAR) ADC. Operating from a single 2.5V supply, the LTC2377-16 supports a large and flexible  $\pm V_{REF}$  fully differential input range with  $V_{REF}$  ranging from 2.5V to 5.1V, making it ideal for high performance applications which require a wide dynamic range. The LTC2377-16 achieves  $\pm 0.5\text{LSB}$  INL max, no missing codes at 16 bits and 97dB SNR.

Fast 500ksps throughput with no cycle latency makes the LTC2377-16 ideally suited for a wide variety of high speed applications. An internal oscillator sets the conversion time, easing external timing considerations. The LTC2377-16 dissipates only 6.8mW at 500ksps, while an auto power-down feature is provided to further reduce power dissipation during inactive periods.

The LTC2377-16 features a unique digital gain compression (DGC) function, which eliminates the driver amplifier's negative supply while preserving the full resolution of the ADC. When enabled, the ADC performs a digital scaling function that maps zero-scale code from 0V to  $0.1 \cdot V_{REF}$  and full-scale code from  $V_{REF}$  to  $0.9 \cdot V_{REF}$ . For a typical reference voltage of 5V, the full-scale input range is now 0.5V to 4.5V, which provides adequate headroom for powering the driving amplifier from a single 5.5V supply.

### CONVERTER OPERATION

The LTC2377-16 operates in two phases. During the acquisition phase, the charge redistribution capacitor D/A converter (CDAC) is connected to the  $IN^+$  and  $IN^-$  pins to sample the differential analog input voltage. A rising edge on the CNV pin initiates a conversion. During the conversion phase, the 16-bit CDAC is sequenced through a successive approximation algorithm, effectively comparing the sampled input with binary-weighted fractions of the reference voltage (e.g.  $V_{REF}/2, V_{REF}/4 \dots V_{REF}/65536$ ) using the differential comparator. At the end of conversion, the CDAC output approximates the sampled analog input. The ADC control logic then prepares the 16-bit digital output code for serial transfer.

### TRANSFER FUNCTION

The LTC2377-16 digitizes the full-scale voltage of  $2 \times REF$  into  $2^{16}$  levels, resulting in an LSB size of  $152\mu\text{V}$  with  $REF = 5\text{V}$ . The ideal transfer function is shown in Figure 2. The output data is in 2's complement format.

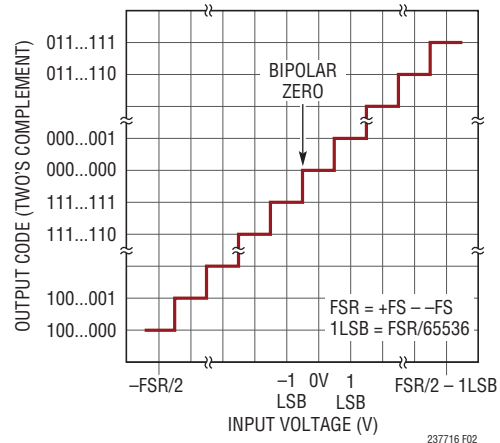

Figure 2. LTC2377-16 Transfer Function

### ANALOG INPUT

The analog inputs of the LTC2377-16 are fully differential in order to maximize the signal swing that can be digitized. The analog inputs can be modeled by the equivalent circuit shown in Figure 3. The diodes at the input provide ESD protection. In the acquisition phase, each input sees approximately  $45\text{pF}$  ( $C_{IN}$ ) from the sampling CDAC in series with  $40\Omega$  ( $R_{ON}$ ) from the on-resistance of the sampling switch. Any unwanted signal that is common to both inputs will be reduced by the common mode rejection of the ADC. The inputs draw a current spike while charging the  $C_{IN}$  capacitors during acquisition. During conversion, the analog inputs draw only a small leakage current.

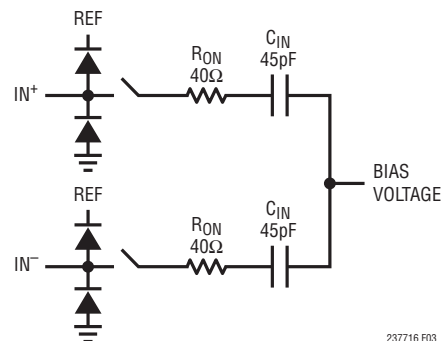

Figure 3. The Equivalent Circuit for the Differential Analog Input of the LTC2377-16

## APPLICATIONS INFORMATION

### INPUT DRIVE CIRCUITS

A low impedance source can directly drive the high impedance inputs of the LTC2377-16 without gain error. A high impedance source should be buffered to minimize settling time during acquisition and to optimize the distortion performance of the ADC. Minimizing settling time is important even for DC inputs, because the ADC inputs draw a current spike when entering acquisition.

For best performance, a buffer amplifier should be used to drive the analog inputs of the LTC2377-16. The amplifier provides low output impedance, which produces fast settling of the analog signal during the acquisition phase. It also provides isolation between the signal source and the current spike the ADC inputs draw.

### Input Filtering

The noise and distortion of the buffer amplifier and signal source must be considered since they add to the ADC noise and distortion. Noisy input signals should be filtered prior to the buffer amplifier input with an appropriate filter to minimize noise. The simple 1-pole RC lowpass filter (LPF1) shown in Figure 4 is sufficient for many applications.

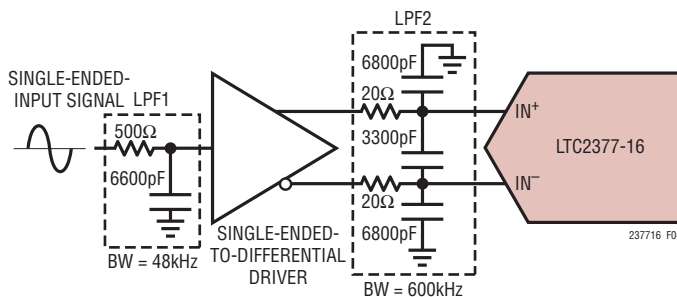

Figure 4. Input Signal Chain

Another filter network consisting of LPF2 should be used between the buffer and ADC input to both minimize the noise contribution of the buffer and to help minimize disturbances reflected into the buffer from sampling transients. Long RC time constants at the analog inputs will slow down the settling of the analog inputs. Therefore, LPF2 requires a wider bandwidth than LPF1. A buffer amplifier with a low noise density must be selected to minimize degradation of the SNR.

High quality capacitors and resistors should be used in the RC filters since these components can add distortion. NPO and silver mica type dielectric capacitors have excellent linearity. Carbon surface mount resistors can generate distortion from self heating and from damage that may occur during soldering. Metal film surface mount resistors are much less susceptible to both problems.

### Single-Ended-to-Differential Conversion

For single-ended input signals, a single-ended to differential conversion circuit must be used to produce a differential signal at the inputs of the LTC2377-16. The LT6350 ADC driver is recommended for performing single-ended-to-differential conversions. The LT6350 is flexible and may be configured to convert single-ended signals of various amplitudes to the  $\pm 5V$  differential input range of the LTC2377-16. The LT6350 is also available in H-grade to complement the extended temperature operation of the LTC2377-16 up to 125°C.

Figure 5a shows the LT6350 being used to convert a 0V to 5V single-ended input signal. In this case, the first amplifier is configured as a unity gain buffer and the single-ended input signal directly drives the high-impedance input of the amplifier. As shown in the FFT of Figure 5b, the LT6350 drives the LTC2377-16 to near full data sheet performance.

The LT6350 can also be used to buffer and convert large true bipolar signals which swing below ground to the  $\pm 5V$  differential input range of the LTC2377-16 in order to maximize the signal swing that can be digitized. Figure 6a shows the LT6350 being used to convert a  $\pm 10V$  true bipolar signal for use by the LTC2377-16. In this case, the first amplifier in the LT6350 is configured as an inverting amplifier stage, which acts to attenuate and level shift the input signal to the 0V to 5V input range of the LTC2377-16. In the inverting amplifier configuration, the single-ended input signal source no longer directly drives a high impedance input of the first amplifier. The input impedance is instead set by resistor  $R_{IN}$ .  $R_{IN}$  must be chosen carefully based on the source impedance of the signal source. Higher values of  $R_{IN}$  tend to degrade both the noise and distortion of the LT6350 and LTC2377-16 as a system.

APPLICATIONS INFORMATION

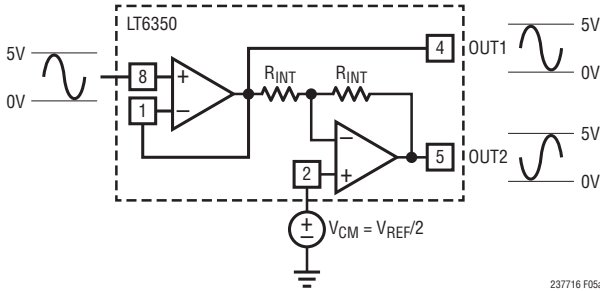

Figure 5a. LT6350 Converting a 0V-5V Single-Ended Signal to a ±5V Differential Input Signal

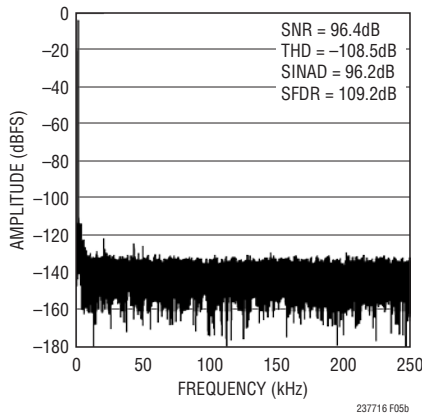

Figure 5b. 32k Point FFT Plot with  $f_{IN} = 2\text{kHz}$  for Circuit Shown in Figure 5a

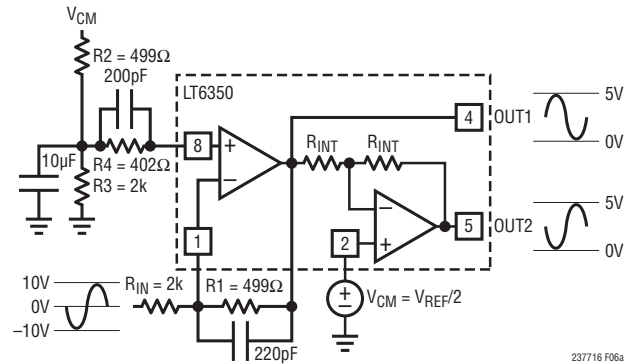

Figure 6a. LT6350 Converting a ±10V Single-Ended Signal to a ±5V Differential Input Signal

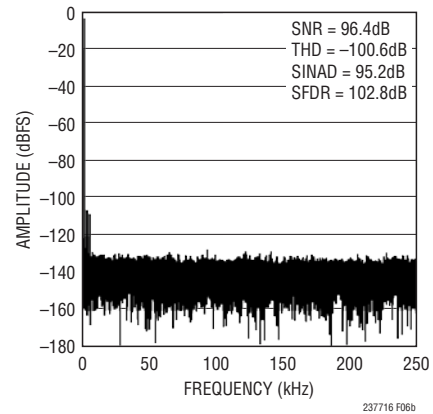

Figure 6b. 32k Point FFT Plot with  $f_{IN} = 2\text{kHz}$  for Circuit Shown in Figure 6a

R1, R2, R3 and R4 must be selected in relation to  $R_{IN}$  to achieve the desired attenuation and to maintain a balanced input impedance in the first amplifier. Table 1 shows the resulting SNR and THD for several values of  $R_{IN}$ , R1, R2, R3 and R4 in this configuration. Figure 6b shows the resulting FFT when using the LT6350 as shown in Figure 6a.

Table 1. SNR, THD vs  $R_{IN}$  for ±10V Single-Ended Input Signal.

$R_{IN}$ (Ω)	R1 (Ω)	R2 (Ω)	R3 (Ω)	R4 (Ω)	SNR (dB)	THD (dB)
2k	499	499	2k	402	96.4	-101
10k	2.49k	2.49k	10k	2k	96.3	-92
100k	24.9k	24.9k	100k	20k	96.3	-98

Fully Differential Inputs

To achieve the full distortion performance of the LTC2377-16, a low distortion fully differential signal source driven through the LT6203 configured as two unity gain buffers as shown in Figure 7 can be used to get the full data sheet THD specification of -123dB.

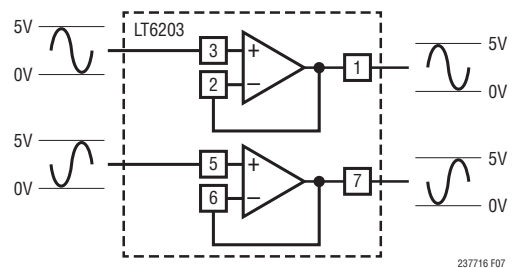
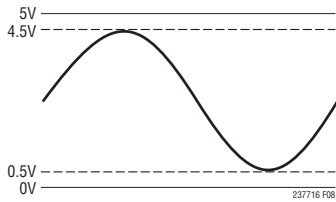

Figure 7. LT6203 Buffering a Fully Differential Signal Source

Digital Gain Compression

The LTC2377-16 offers a digital gain compression (DGC) feature which defines the full-scale input swing to be between 10% and 90% of the  $\pm V_{REF}$  analog input range. To enable digital gain compression, bring the REF/DGC pin low. This feature allows the LT6350 to be powered off of a single +5.5V supply since each input swings between 0.5V and 4.5V as shown in Figure 8. Needing only one

## APPLICATIONS INFORMATION



**Figure 8. Input Swing of the LTC2377 with Gain Compression Enabled**

positive supply to power the LT6350 results in additional power savings for the entire system.

Figure 9a shows how to configure the LT6350 to accept a  $\pm 10V$  true bipolar input signal and attenuate and level shift the signal to the reduced input range of the LTC2377-16 when digital gain compression is enabled. Figure 9b shows an FFT plot with the LTC2377-16 being driven by the LT6350 with digital gain compression enabled.

### ADC REFERENCE

The LTC2377-16 requires an external reference to define its input range. A low noise, low temperature drift reference is critical to achieving the full data sheet performance of the ADC. Linear Technology offers a portfolio of high performance references designed to meet the needs of

many applications. With its small size, low power and high accuracy, the LTC6655-5 is particularly well suited for use with the LTC2377-16. The LTC6655-5 offers 0.025% (max) initial accuracy and 2ppm/ $^{\circ}C$  (max) temperature coefficient for high precision applications. The LTC6655-5 is fully specified over the H-grade temperature range and complements the extended temperature operation of the LTC2377-16 up to 125 $^{\circ}C$ . We recommend bypassing the LTC6655-5 with a 47 $\mu F$  ceramic capacitor (X5R, 0805 size) close to the REF pin.

The REF pin of the LTC2377-16 draws charge ( $Q_{CONV}$ ) from the 47 $\mu F$  bypass capacitor during each conversion cycle. The reference replenishes this charge with a DC current,  $I_{REF} = Q_{CONV}/t_{CYC}$ . The DC current draw of the REF pin,  $I_{REF}$ , depends on the sampling rate and output code. If the LTC2377-16 is used to continuously sample a signal at a constant rate, the LTC6655-5 will keep the deviation of the reference voltage over the entire code span to less than 0.5LSBs.

When idling, the REF pin on the LTC2377-16 draws only a small leakage current ( $< 1\mu A$ ). In applications where a burst of samples is taken after idling for long periods as shown in Figure 10,  $I_{REF}$  quickly goes from approximately

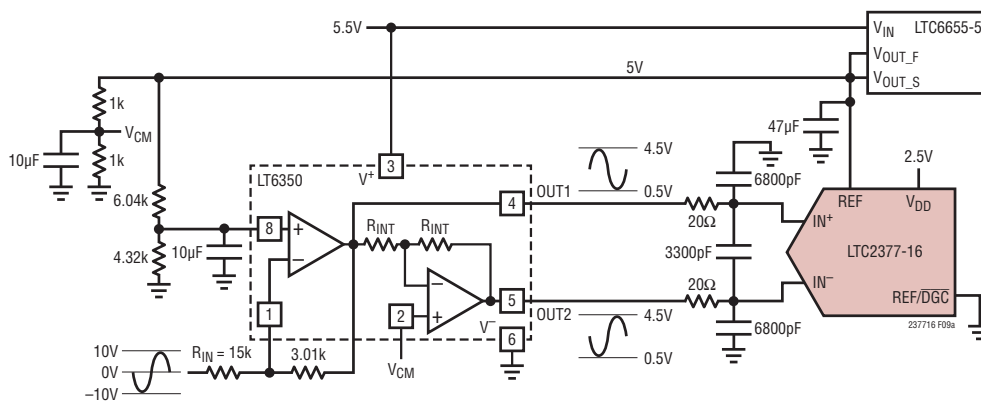

**Figure 9a. LT6350 Configured to Accept a  $\pm 10V$  Input Signal While Running Off of a Single 5.5V Supply When Digital Gain Compression Is Enabled in the LTC2377-16**

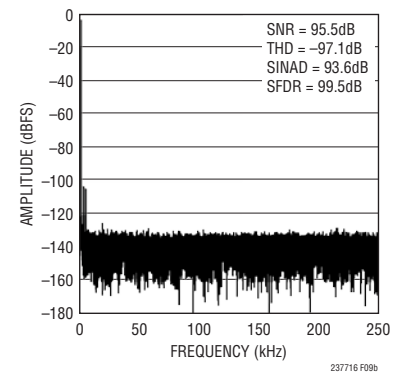

**Figure 9b. 32k Point FFT Plot with  $f_{IN} = 2kHz$  for Circuit Shown in Figure 9a**

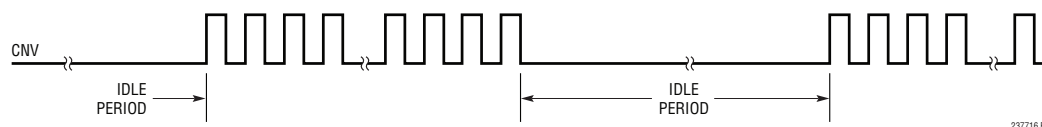

**Figure 10. CNV Waveform Showing Burst Sampling**

## APPLICATIONS INFORMATION

0 $\mu$ A to a maximum of 0.4mA at 500ksps. This step in DC current draw triggers a transient response in the reference that must be considered since any deviation in the reference output voltage will affect the accuracy of the output code. In applications where the transient response of the reference is important, the fast settling LTC6655-5 reference is also recommended.

### DYNAMIC PERFORMANCE

Fast Fourier Transform (FFT) techniques are used to test the ADC's frequency response, distortion and noise at the rated throughput. By applying a low distortion sine wave and analyzing the digital output using an FFT algorithm, the ADC's spectral content can be examined for frequencies outside the fundamental. The LTC2377-16 provides guaranteed tested limits for both AC distortion and noise measurements.

#### Signal-to-Noise and Distortion Ratio (SINAD)

The signal-to-noise and distortion ratio (SINAD) is the ratio between the RMS amplitude of the fundamental input frequency and the RMS amplitude of all other frequency components at the A/D output. The output is band-limited to frequencies from above DC and below half the sampling frequency. Figure 11 shows that the LTC2377-16 achieves a typical SINAD of 97dB at a 500kHz sampling rate with a 2kHz input.

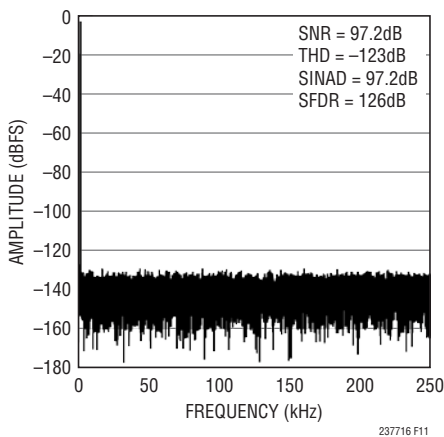

Figure 11. 32k Point FFT with  $f_{IN} = 2\text{kHz}$  of the LTC2377-16

#### Signal-to-Noise Ratio (SNR)

The signal-to-noise ratio (SNR) is the ratio between the RMS amplitude of the fundamental input frequency and the RMS amplitude of all other frequency components except the first five harmonics and DC. Figure 11 shows that the LTC2377-16 achieves a typical SNR of 97dB at a 500kHz sampling rate with a 2kHz input.

#### Total Harmonic Distortion (THD)

Total Harmonic Distortion (THD) is the ratio of the RMS sum of all harmonics of the input signal to the fundamental itself. The out-of-band harmonics alias into the frequency band between DC and half the sampling frequency ( $f_{SAMPL}/2$ ). THD is expressed as:

$$\text{THD} = 20 \log \frac{\sqrt{V_2^2 + V_3^2 + V_4^2 + \dots + V_N^2}}{V_1}$$

where  $V_1$  is the RMS amplitude of the fundamental frequency and  $V_2$  through  $V_N$  are the amplitudes of the second through Nth harmonics.

### POWER CONSIDERATIONS

The LTC2377-16 provides two power supply pins: the 2.5V power supply ( $V_{DD}$ ), and the digital input/output interface power supply ( $OV_{DD}$ ). The flexible  $OV_{DD}$  supply allows the LTC2377-16 to communicate with any digital logic operating between 1.8V and 5V, including 2.5V and 3.3V systems.

#### Power Supply Sequencing

The LTC2377-16 does not have any specific power supply sequencing requirements. Care should be taken to adhere to the maximum voltage relationships described in the Absolute Maximum Ratings section. The LTC2377-16 has a power-on-reset (POR) circuit that will reset the LTC2377-16 at initial power-up or whenever the power supply voltage drops below 1V. Once the supply voltage re-enters the nominal supply voltage range, the POR will reinitialize the ADC. No conversions should be initiated until 20 $\mu$ s after a POR event to ensure the reinitialization period has ended. Any conversions initiated before this time will produce invalid results.



## APPLICATIONS INFORMATION

### TIMING AND CONTROL

#### CNV Timing

The LTC2377-16 conversion is controlled by CNV. A rising edge on CNV will start a conversion and power up the LTC2377-16. Once a conversion has been initiated, it cannot be restarted until the conversion is complete. For optimum performance, CNV should be driven by a clean low jitter signal. Converter status is indicated by the BUSY output which remains high while the conversion is in progress. To ensure that no errors occur in the digitized results, any additional transitions on CNV should occur within 40ns from the start of the conversion or after the conversion has been completed. Once the conversion has completed, the LTC2377-16 powers down and begins acquiring the input signal.

#### Acquisition

A proprietary sampling architecture allows the LTC2377-16 to begin acquiring the input signal for the next conversion 527ns after the start of the current conversion. This extends the acquisition time to 1.46 $\mu$ s, easing settling requirements and allowing the use of extremely low power ADC drivers. (Refer to the Timing Diagram.)

#### Internal Conversion Clock

The LTC2377-16 has an internal clock that is trimmed to achieve a maximum conversion time of 1.5 $\mu$ s.

#### Auto Power-Down

The LTC2377-16 automatically powers down after a conversion has been completed and powers up once a new conversion is initiated on the rising edge of CNV. During power down, data from the last conversion can be clocked out. To minimize power dissipation during power down, disable SDO and turn off SCK. The auto power-down feature will reduce the power dissipation of the LTC2377-16 as the sampling frequency is reduced. Since power is consumed only during a conversion, the LTC2377-16 remains powered-down for a larger fraction of the conversion cycle ( $t_{CYC}$ ) at lower sample rates, thereby reducing the average power dissipation which scales with the sampling rate as shown in Figure 12.

### DIGITAL INTERFACE

The LTC2377-16 has a serial digital interface. The flexible  $OV_{DD}$  supply allows the LTC2377-16 to communicate with any digital logic operating between 1.8V and 5V, including 2.5V and 3.3V systems.

The serial output data is clocked out on the SDO pin when an external clock is applied to the SCK pin if SDO is enabled. Clocking out the data after the conversion will yield the best performance. With a shift clock frequency of at least 40MHz, a 500ksp/s throughput is still achieved. The serial output data changes state on the rising edge of SCK and can be captured on the falling edge or next rising edge of SCK. D15 remains valid till the first rising edge of SCK.

The serial interface on the LTC2377-16 is simple and straightforward to use. The following sections describe the operation of the LTC2377-16. Several modes are provided depending on whether a single or multiple ADCs share the SPI bus or are daisy-chained.

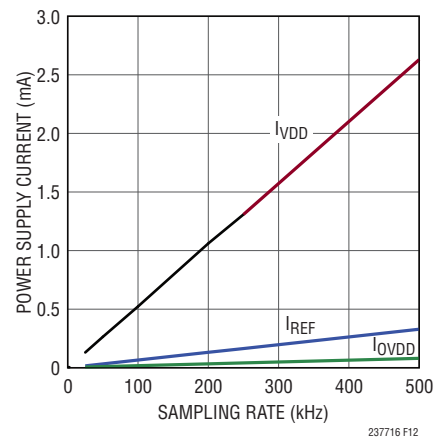

Figure 12. Power Supply Current of the LTC2377-16 Versus Sampling Rate



## TIMING DIAGRAMS

### Normal Mode, Single Device

When CHAIN = 0, the LTC2377-16 operates in normal mode. In normal mode, RDL/SDI enables or disables the serial data output pin SDO. If RDL/SDI is high, SDO is in high impedance. If RDL/SDI is low, SDO is driven.

Figure 13 shows a single LTC2377-16 operated in normal mode with CHAIN and RDL/SDI tied to ground. With RDL/SDI grounded, SDO is enabled and the MSB(D15) of the new conversion data is available at the falling edge of BUSY. This is the simplest way to operate the LTC2377-16.

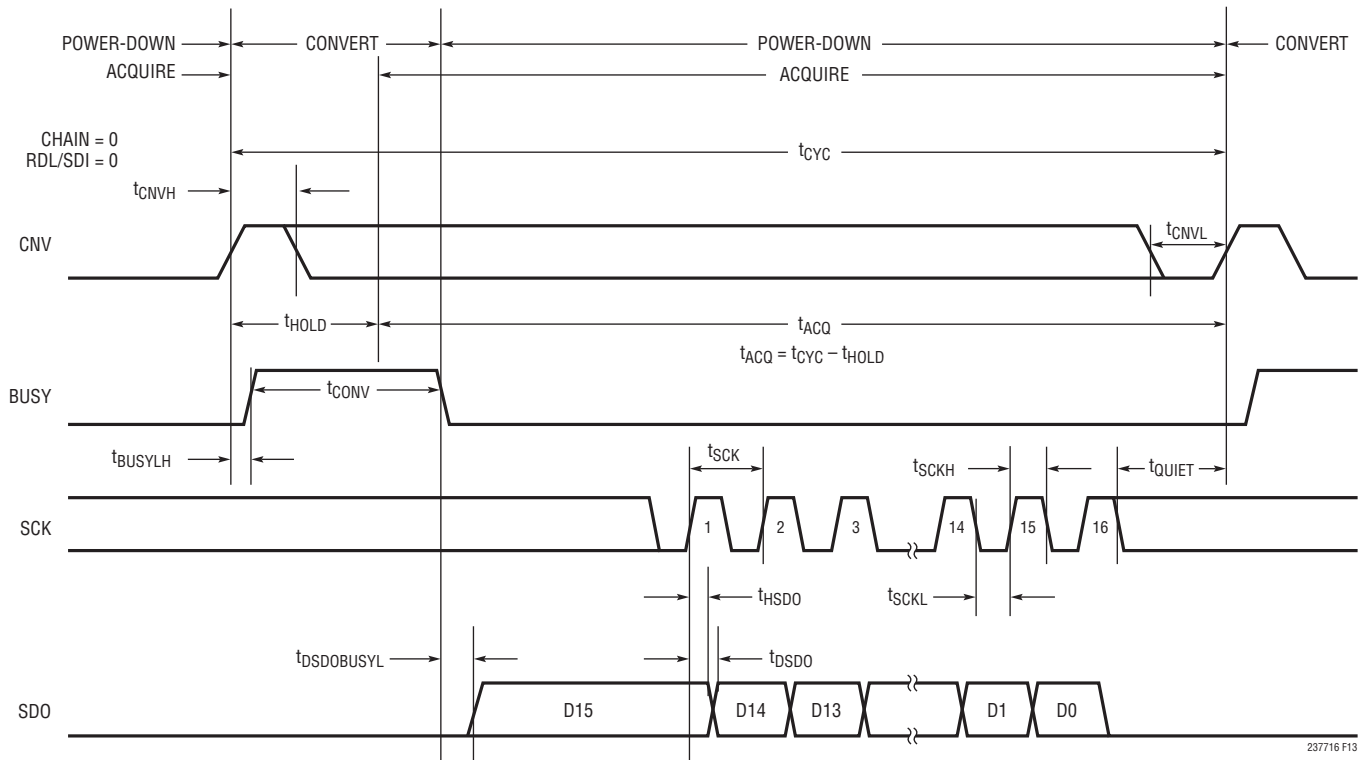
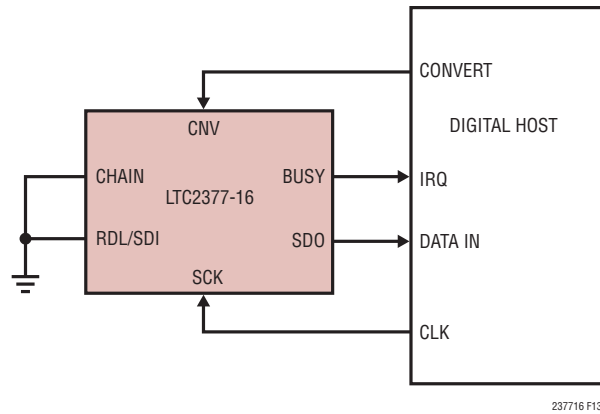

Figure 13. Using a Single LTC2377-16 in Normal Mode

# TIMING DIAGRAMS

## Normal Mode, Multiple Devices

Figure 14 shows multiple LTC2377-16 devices operating in normal mode (CHAIN = 0) sharing CNV, SCK and SDO. By sharing CNV, SCK and SDO, the number of required signals to operate multiple ADCs in parallel is reduced.

Since SDO is shared, the RDL/SDI input of each ADC must be used to allow only one LTC2377-16 to drive SDO at a time in order to avoid bus conflicts. As shown in Figure 14, the RDL/SDI inputs idle high and are individually brought low to read data out of each device between conversions. When RDL/SDI is brought low, the MSB of the selected device is output onto SDO.

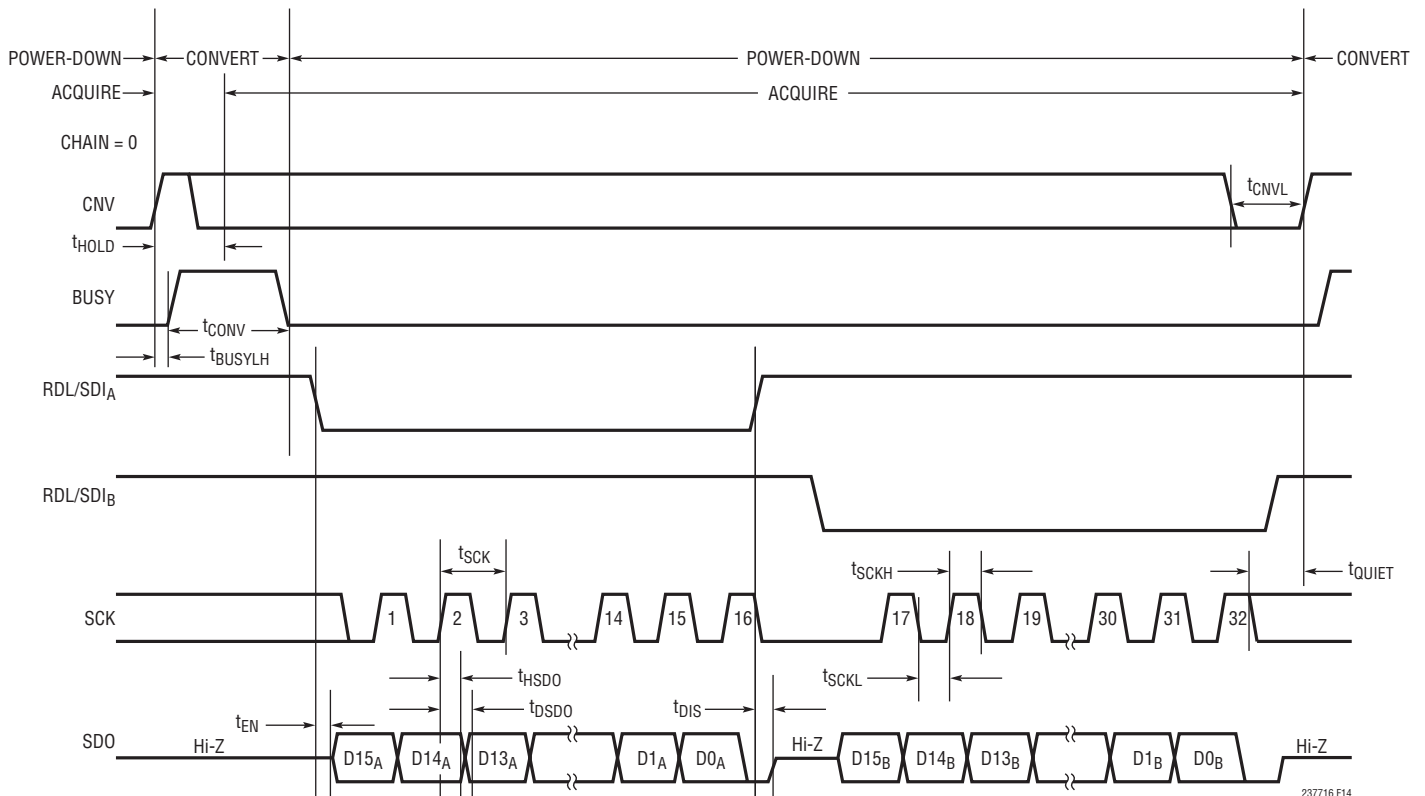
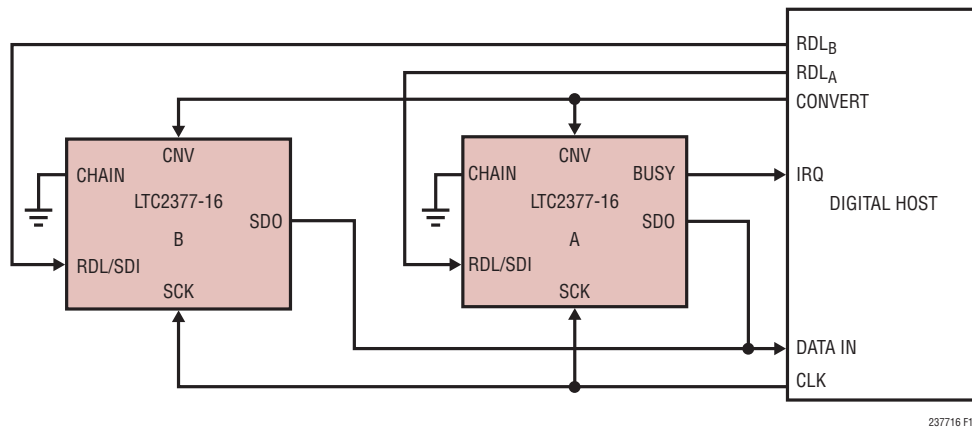

Figure 14. Normal Mode With Multiple Devices Sharing CNV, SCK and SDO

## TIMING DIAGRAMS

### Chain Mode, Multiple Devices

When CHAIN =  $OV_{DD}$ , the LTC2377-16 operates in chain mode. In chain mode, SDO is always enabled and RDL/SDI serves as the serial data input pin (SDI) where daisy-chain data output from another ADC can be input.

This is useful for applications where hardware constraints may limit the number of lines needed to interface to a large number of converters. Figure 15 shows an example with two daisy-chained devices. The MSB of converter A will appear at SDO of converter B after 16 SCK cycles. The MSB of converter A is clocked in at the SDI/RDL pin of converter B on the rising edge of the first SCK.

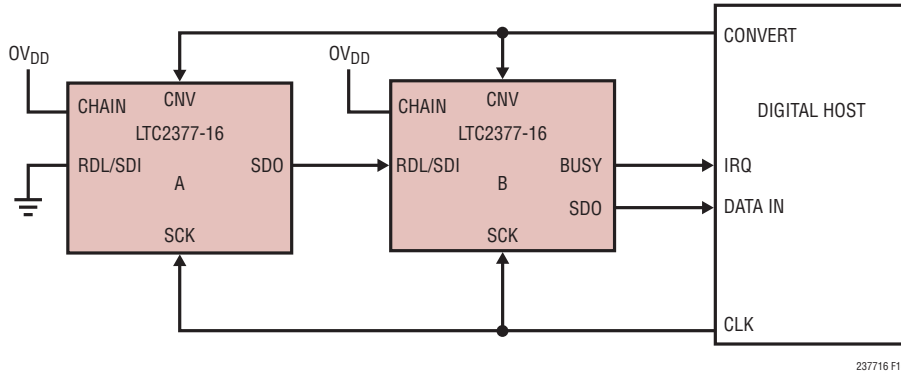

237716 F16a

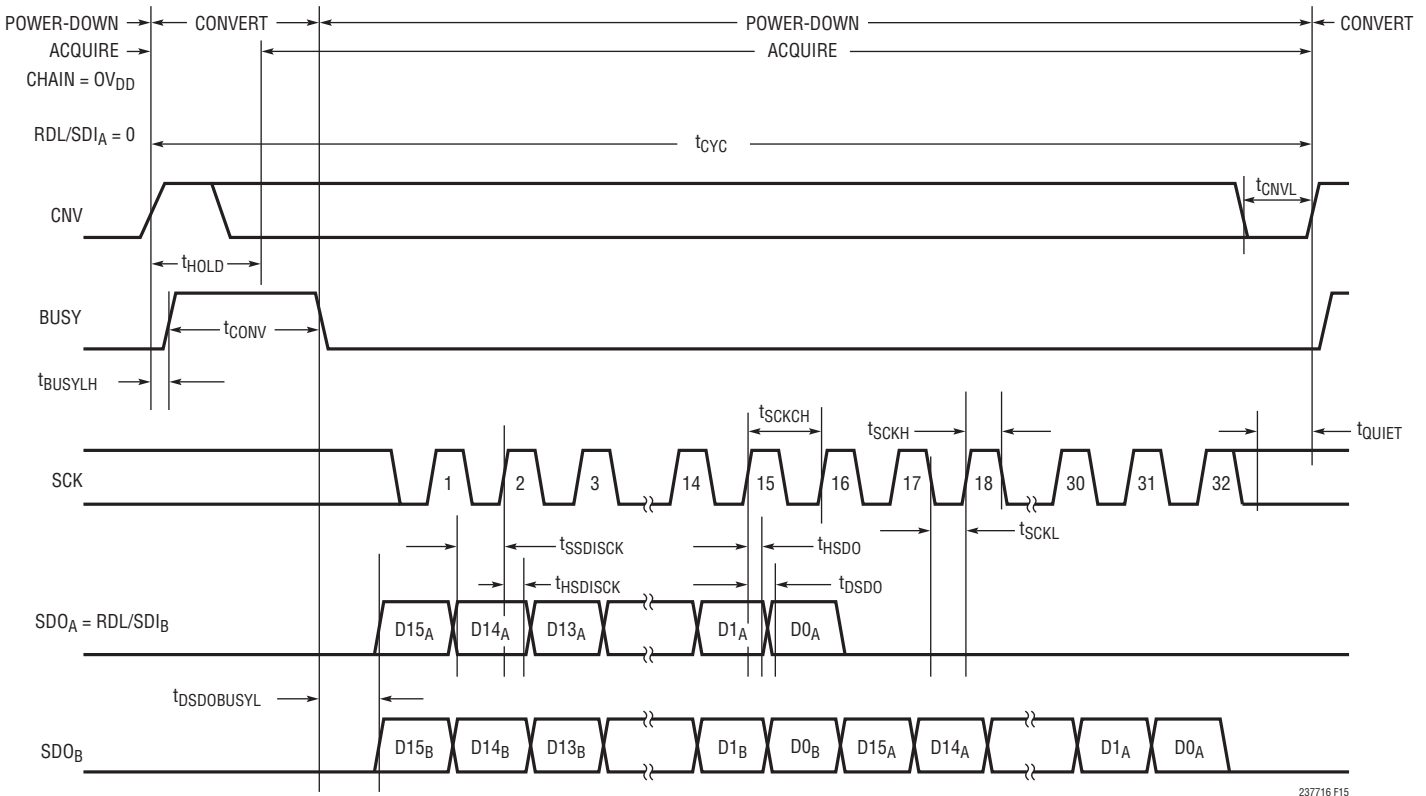

237716 F15

Figure 15. Chain Mode Timing Diagram

## BOARD LAYOUT

To obtain the best performance from the LTC2377-16 a printed circuit board is recommended. Layout for the printed circuit board (PCB) should ensure the digital and analog signal lines are separated as much as possible. In particular, care should be taken not to run any digital clocks or signals alongside analog signals or underneath the ADC.

### Recommended Layout

The following is an example of a recommended PCB layout. A single solid ground plane is used. Bypass capacitors to the supplies are placed as close as possible to the supply pins. Low impedance common returns for these bypass capacitors are essential to the low noise operation of the ADC. The analog input traces are screened by ground. For more details and information refer to DC1783A, the evaluation kit for the LTC2377-16.

Partial Top Silkscreen

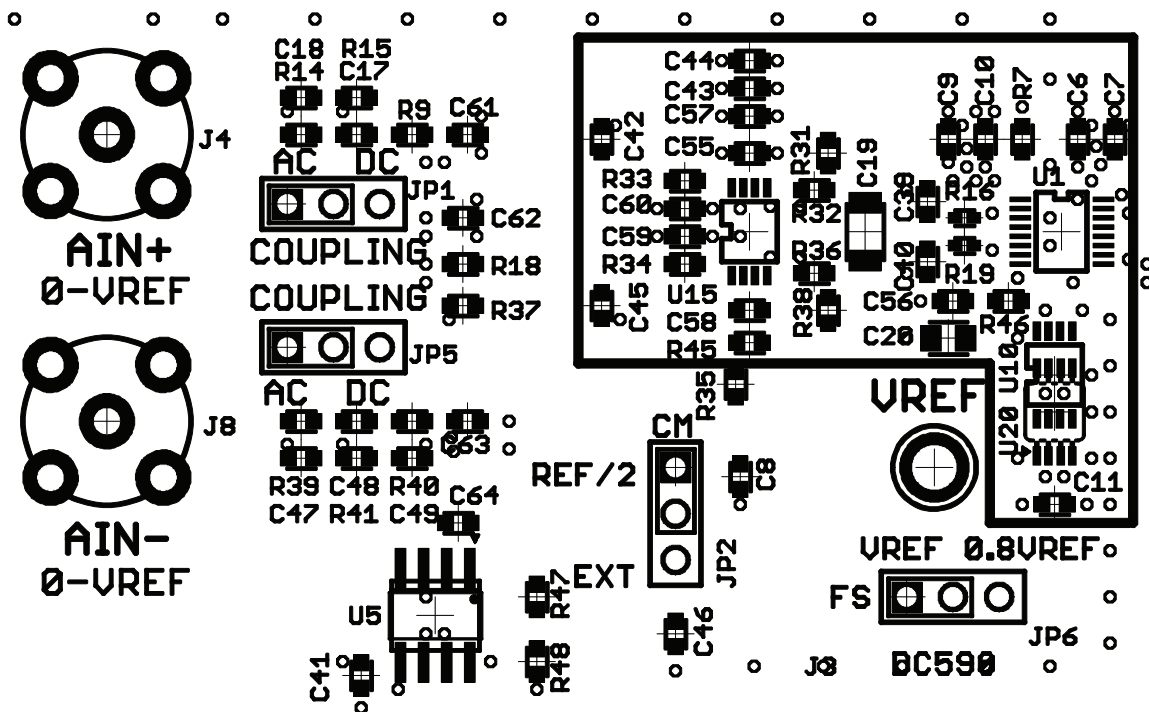

# BOARD LAYOUT

Partial Layer 1 Component Side

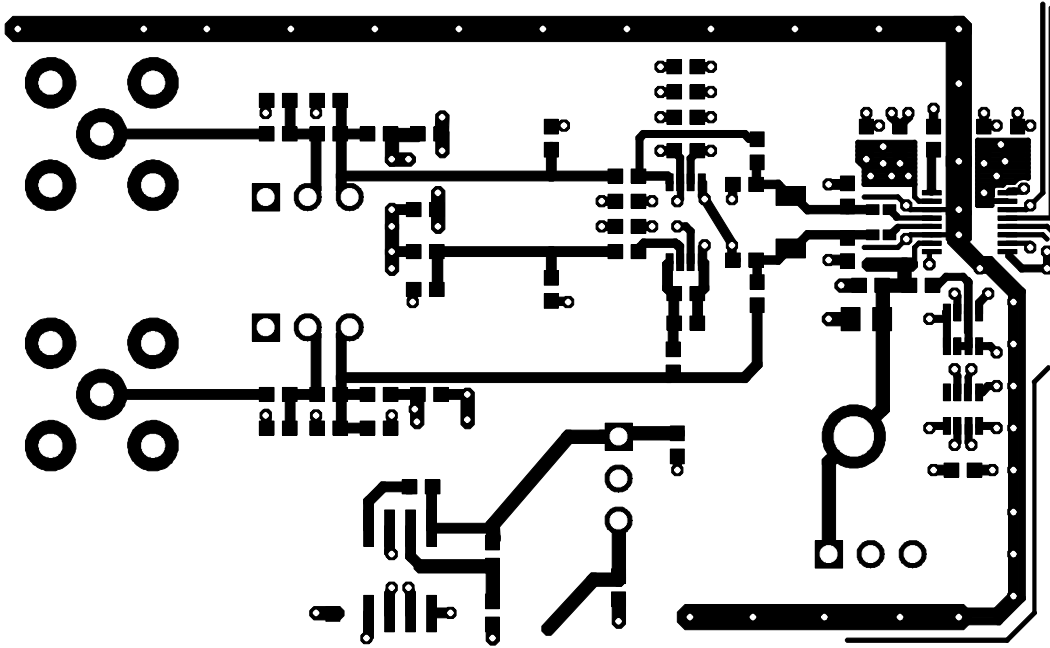

Partial Layer 2 Ground Plane

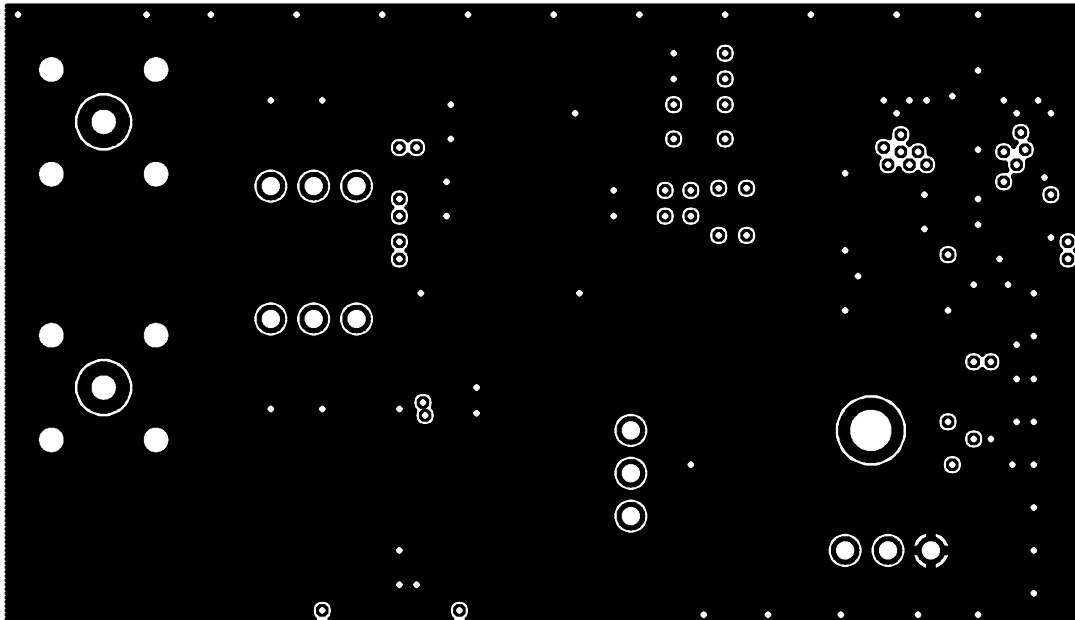

**BOARD LAYOUT**

Partial Layer 3 PWR Plane

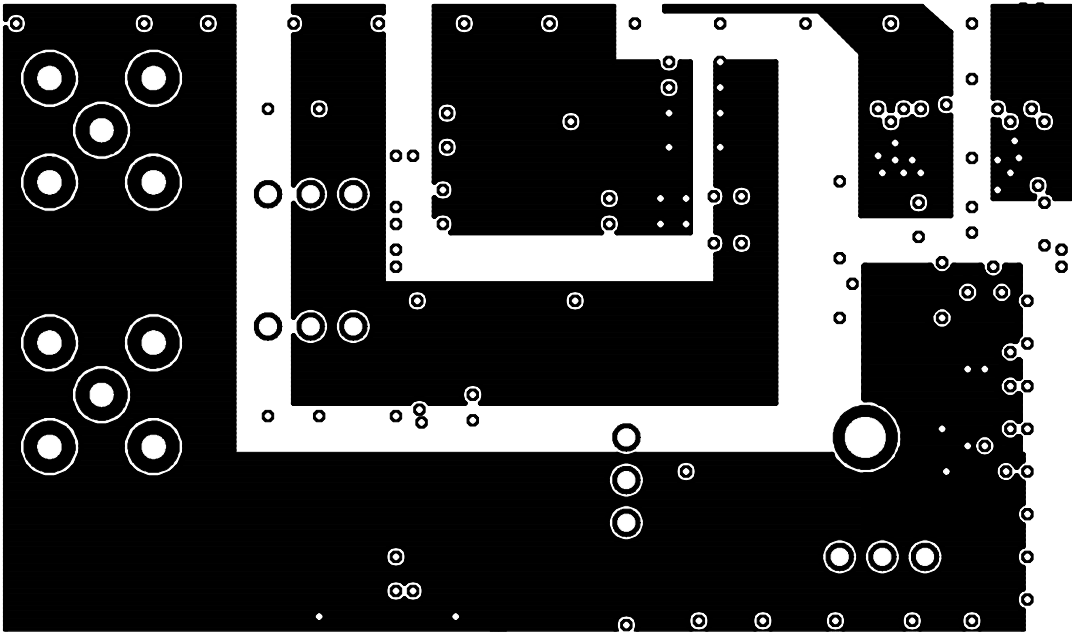

Partial Layer 4 Bottom Layer

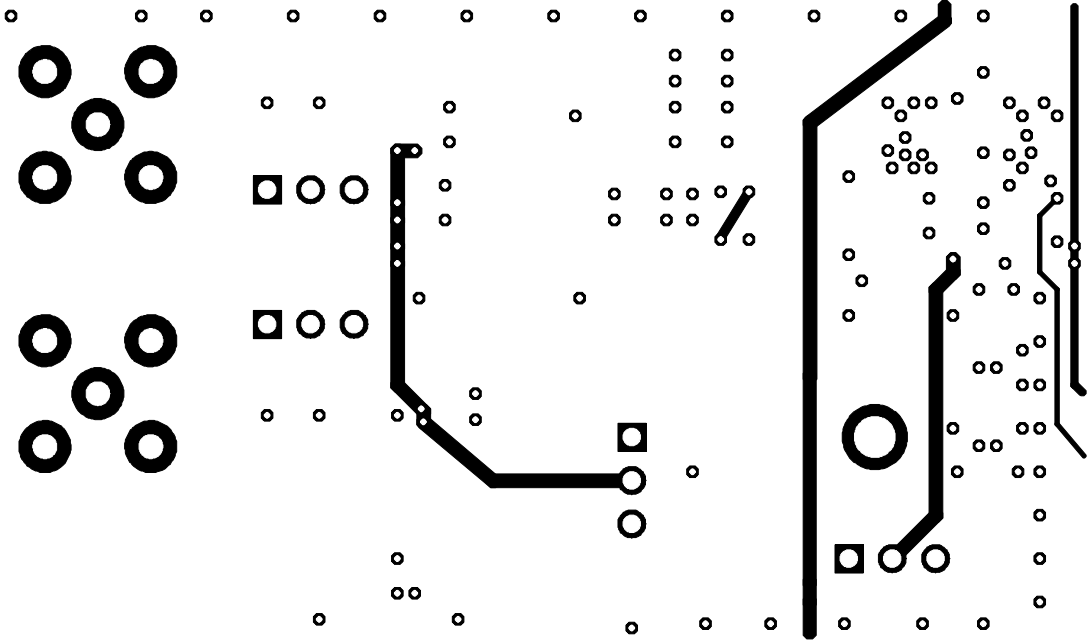

BOARD LAYOUT

Partial Schematic of Demo Board

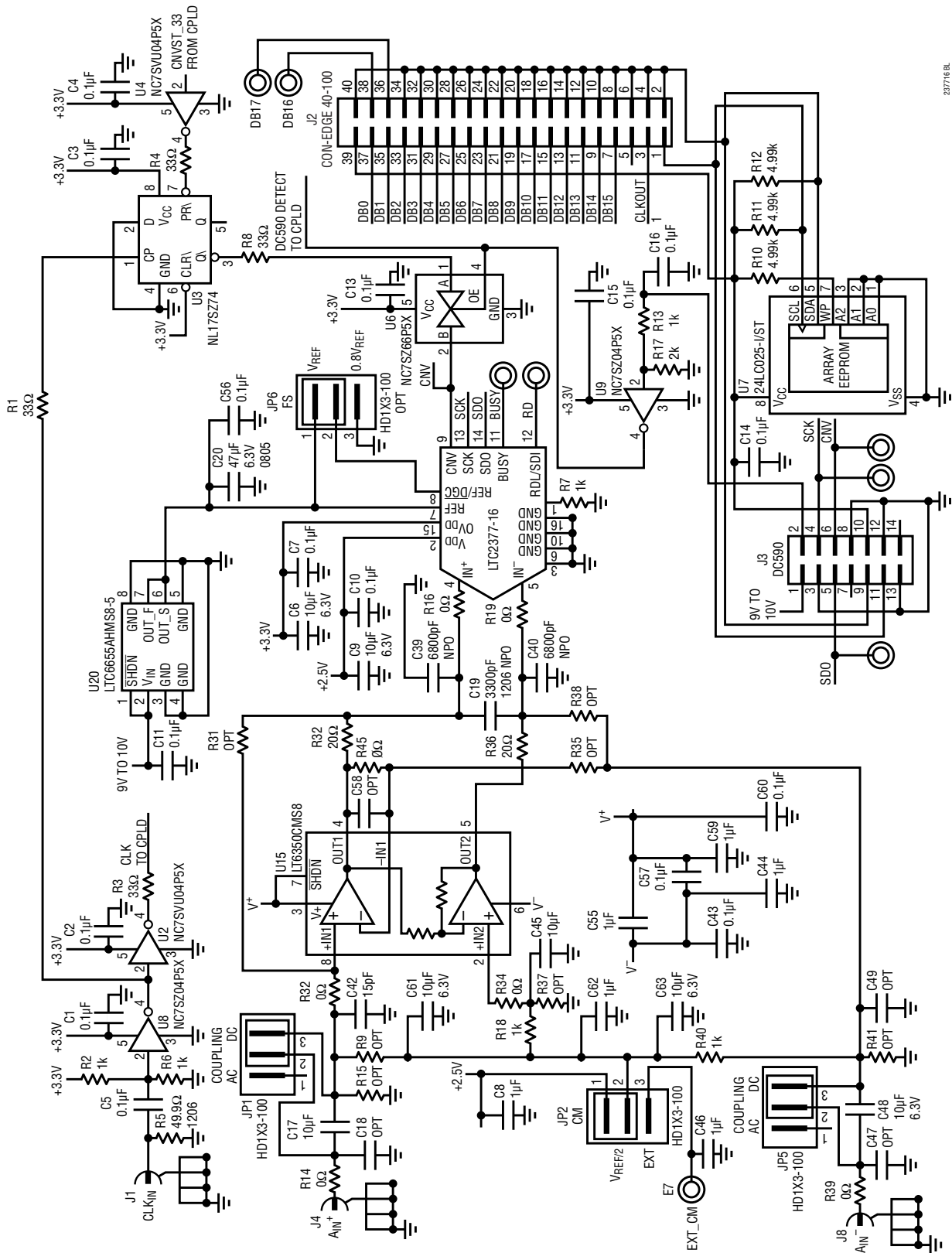

237716B



# PACKAGE DESCRIPTION

## DE Package 16-Lead Plastic DFN (4mm × 3mm) (Reference LTC DWG # 05-08-1732 Rev 0)

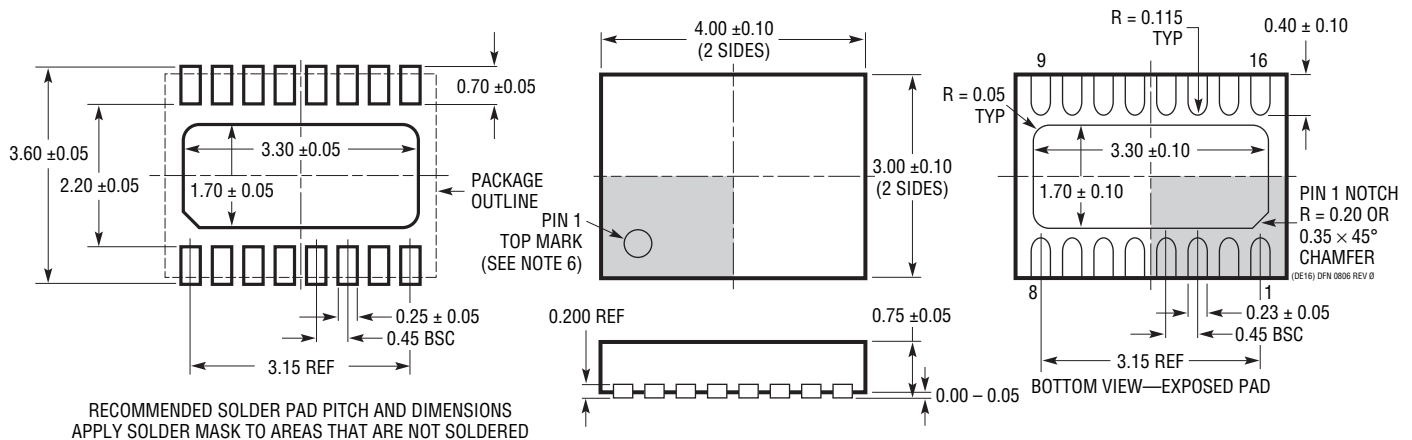

- NOTE:
1. DRAWING PROPOSED TO BE MADE VARIATION OF VERSION (WGED-3) IN JEDEC PACKAGE OUTLINE MO-229
  2. DRAWING NOT TO SCALE
  3. ALL DIMENSIONS ARE IN MILLIMETERS
  4. DIMENSIONS OF EXPOSED PAD ON BOTTOM OF PACKAGE DO NOT INCLUDE MOLD FLASH. MOLD FLASH, IF PRESENT, SHALL NOT EXCEED 0.15mm ON ANY SIDE
  5. EXPOSED PAD SHALL BE SOLDER PLATED
  6. SHADED AREA IS ONLY A REFERENCE FOR PIN 1 LOCATION ON THE TOP AND BOTTOM OF PACKAGE

## MS Package 16-Lead Plastic MSOP (Reference LTC DWG # 05-08-1669 Rev 0)

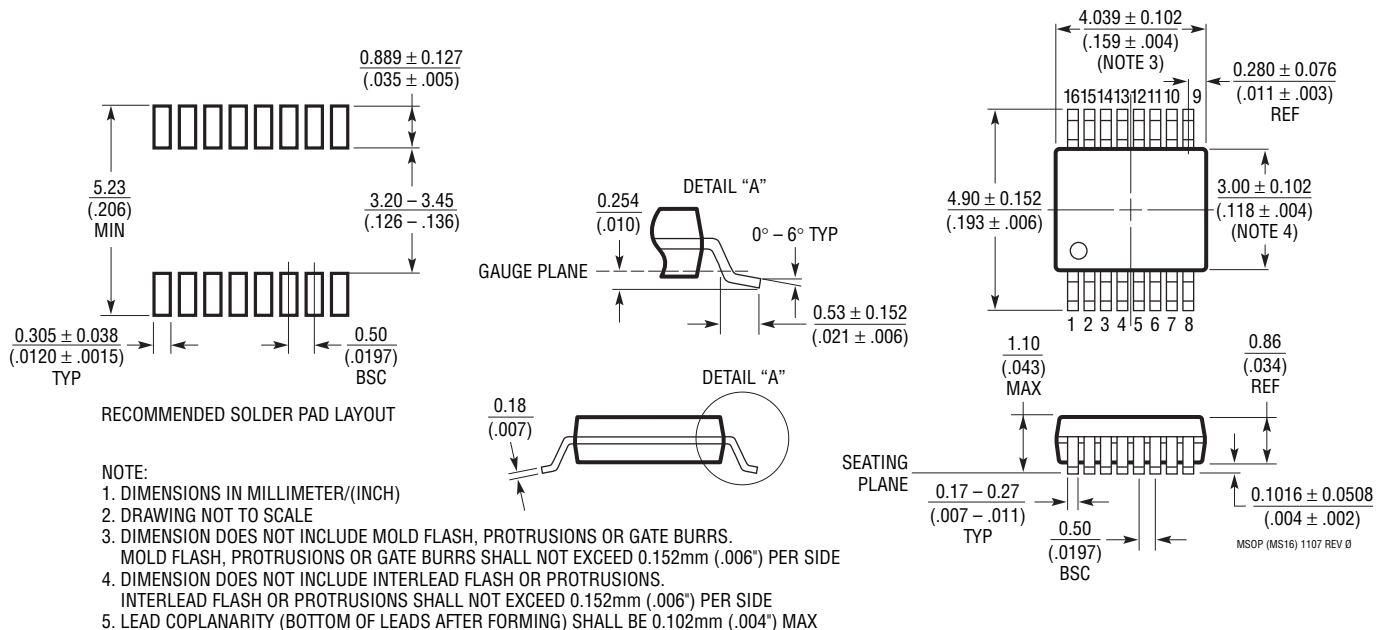

## TYPICAL APPLICATION

LT6350 Configured to Accept a  $\pm 10V$  Input Signal While Running Off of a Single 5.5V Supply When Digital Gain Compression Is Enabled in the LTC2377-16

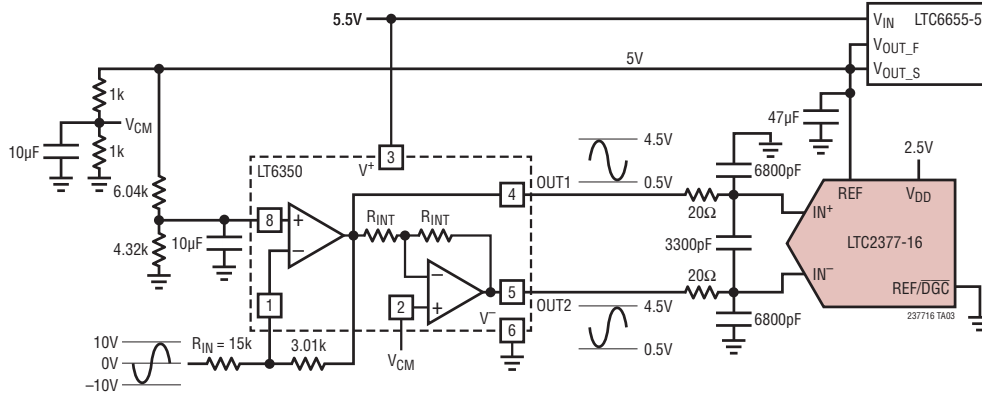

## RELATED PARTS

PART NUMBER	DESCRIPTION	COMMENTS
<b>ADCs</b>		
LTC2379-18	18-Bit, 1.6Msps, Serial, Low Power ADC	2.5V Supply, Differential Input, 101.2dB SNR, $\pm 5V$ Input Range, DGC, MSOP-16 and 4mm $\times$ 3mm DFN-16 Packages
LTC2380-16	16-Bit, 2Msps Serial, Low Power ADC	2.5V Supply, Differential Input, 96.2dB SNR, $\pm 5V$ Input Range, DGC, MSOP-16 and 4mm $\times$ 3mm DFN-16 Packages
LTC2383-16/LTC2382-16/LTC2381-16	16-Bit, 1Msps/500kps/250kps Serial, Low Power ADC	2.5V Supply, Differential Input, 92dB SNR, $\pm 2.5V$ Input Range, Pin Compatible Family in MSOP-16 and 4mm $\times$ 3mm DFN-16 Packages
LTC2393-16/LTC2392-16/LTC2391-16	16-Bit, 1Msps/500kps/250kps Parallel/Serial ADC	5V Supply, Differential Input, 94dB SNR, $\pm 4.096V$ Input Range, Pin Compatible Family in 7mm $\times$ 7mm LQFP-48 and QFN-48 Packages
LTC2362	12-Bit, 500kps Serial ADC	2.35V to 3.6V, 3.3mW, 6- and 8-Lead TSOT-23 Packages
LTC2302/LTC2306	12-Bit, 500kps, 1-/2-Channel, Low Noise, ADC	5V Supply, 14mW at 500kps, DFN-10 Package
LTC2355-14/LTC2356-14	14-Bit, 3.5Msps Serial ADC	3.3V Supply, 1-Channel, Unipolar/Bipolar, 18mW, MSOP-10 Package
<b>DACS</b>		
LTC2757	18-Bit, Single Parallel $I_{OUT}$ SoftSpan™ DAC	$\pm 1LSB$ INL/DNL, Software-Selectable Ranges, 7mm $\times$ 7mm LQFP-48 Package
LTC2641	16-Bit/14-Bit/12-Bit Single Serial $V_{OUT}$ DACs	$\pm 1LSB$ INL/DNL, MSOP-8 Package, 0V to 5V Output
LTC2630	12-Bit/10-Bit/8-Bit Single $V_{OUT}$ DACs	SC70 6-Pin Package, Internal Reference, $\pm 1LSB$ INL (12 Bits)
<b>REFERENCES</b>		
LTC6655	Precision Low Drift Low Noise Buffered Reference	5V/2.5V, 5ppm/°C, 0.25ppm Peak-to-Peak Noise, MSOP-8 Package
LTC6652	Precision Low Drift Low Noise Buffered Reference	5V/2.5V, 5ppm/°C, 2.1ppm Peak-to-Peak Noise, MSOP-8 Package
<b>AMPLIFIERS</b>		
LT6350	Low Noise Single-Ended-to-Differential ADC Driver	Rail-to-Rail Input and Outputs, 240ns, 0.01% Settling Time
LT6200/LT6200-5/LT6200-10	165MHz/800MHz/1.6GHz Op Amp with Unity Gain/ $AV = 5/AV = 10$	Low Noise Voltage: $0.95nV/\sqrt{Hz}$ (100kHz), Low Distortion: $-80dB$ at 1MHz, TSOT23-6 Package
LT6202/LT6203	Single/Dual 100MHz Rail-to-Rail Input/Output Noise Low Power Amplifiers	$1.9nV/\sqrt{Hz}$ , 3mA Maximum, 100MHz Gain Bandwidth
LTC1992	Low Power, Fully Differential Input/Output Amplifier/Driver Family	1mA Supply Current