

Closed Loop Control Maximizes
MAPM-030400-010C00 and MAPM-030400-060C00 Module Performance

Rev. 1

I. Introduction

The MAPM-030400-010C00 and MAPM-030400-060C00 RF amplifier modules work together to form the basic building block of a 30 MHz to 400 MHz amplifier that can supply over 60 W of output power. With the addition of a few components, gain flatness over frequency and temperature can be maximized over its entire frequency range to create a compact amplifier suitable for digital, AM and FM applications.

II. Description of the Amplifiers and Open Loop Performance

The MAPM-030400-010C00 Pre Amplifier is designed for a fixed 13 dBm input power. The ALC pin is then used to adjust the RF power level from 0 W to over 10 W with a 0 V to 10 V control voltage. The module itself consists of two stages of RF amplification. The first stage is push-pull cascode that can supply about 2 W. A gain-equalization network is included between the stages. The final stage of the preamp is a conventional Class AB silicon bipolar RF power amplifier with transformer-based matching. ALC is accomplished by setting the current through the cascode chain as well as the bias current in the Class AB stage. This module is contained in a compact aluminum housing.

The MAPM-030400-060C00 Power Amp consists of a single stage DMOS transistor with broadband coaxial transformer-based matching. It is in a copper housing for maximum heat transfer.

When both modules are cascaded with a 1.75 dB pad between them, the power transfer curves look like Figure 1. The RF output power at a fixed 4.0 V ALC voltage ranges from 10 W to 94 W – a variation of 9.7 dB. The saturated RF output power ranges from 73 W to over 100 W.

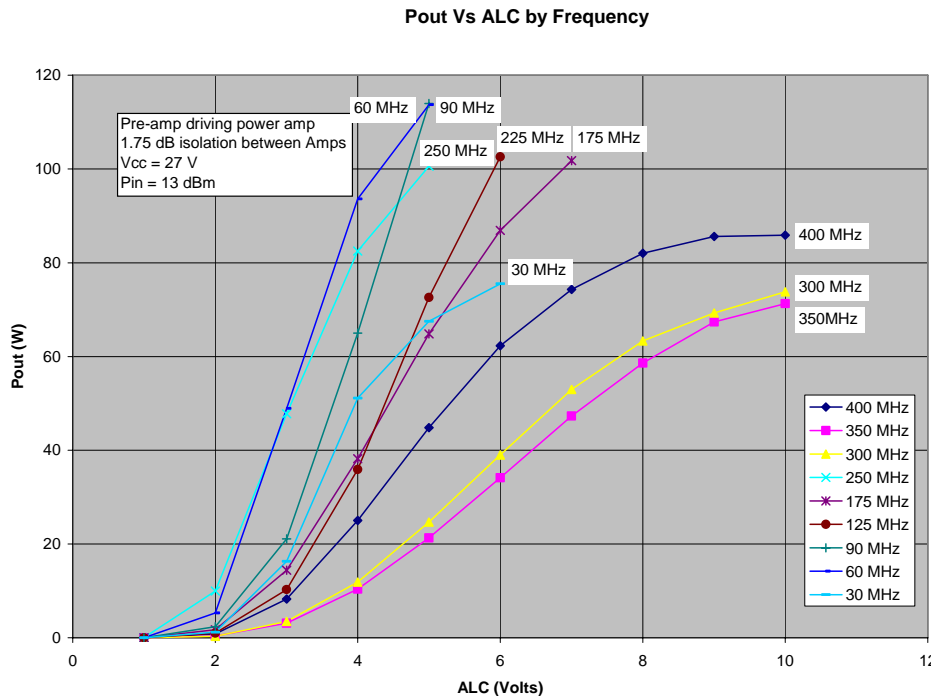

Figure 1. Varying ALC voltages results in gain variation. Closed-loop control can improve gain flatness over frequency and temperature.

Closed Loop Control Maximizes
MAPM-030400-010C00 and MAPM-030400-060C00 Module Performance

Rev. 1

III. Control Loop Circuit Description

The schematic of the control loop circuit is shown in Figure 2. The Pre Amp (AMP6) and Power Amp (AMP7) are connected together with an optional pad between them. Both are connected directly to the 27 V DC supply. The RF output of the Power Amp is connected to the “In” port of the directional coupler. The RF Output is at the “Out” port of this coupler. The FWD coupled port is connected through a 6 dB pad to the input of the detector.

The output of the detector is connected to op amp AMP3 which is configured as a non-inverting buffer. The output of the buffer is connected to the control amp AMP2.

The Audio and Power Set inputs are connected to AMP4 which are configured as an inverting summer. Since the input of the op amp is a virtual ground, the inputs are well isolated, eliminating the need for a coupling capacitor in the Audio input. Because this is an inverting summer, AMP5 is configured as a unity gain inverter to create a positive reference voltage at AMP2. (Because of this double inversion, a negative supply is required for the op amps.) AMP2 compares reference voltage to the detected voltage and sets the Pre Amp ALC voltage to make these voltages equal. R7 and C1 are required to prevent control loop oscillations. Zener diode D1 is used to clamp the ALC voltage at 10 V and -0.7 V, to ensure safe limits for the ALC input of the Pre Amp.

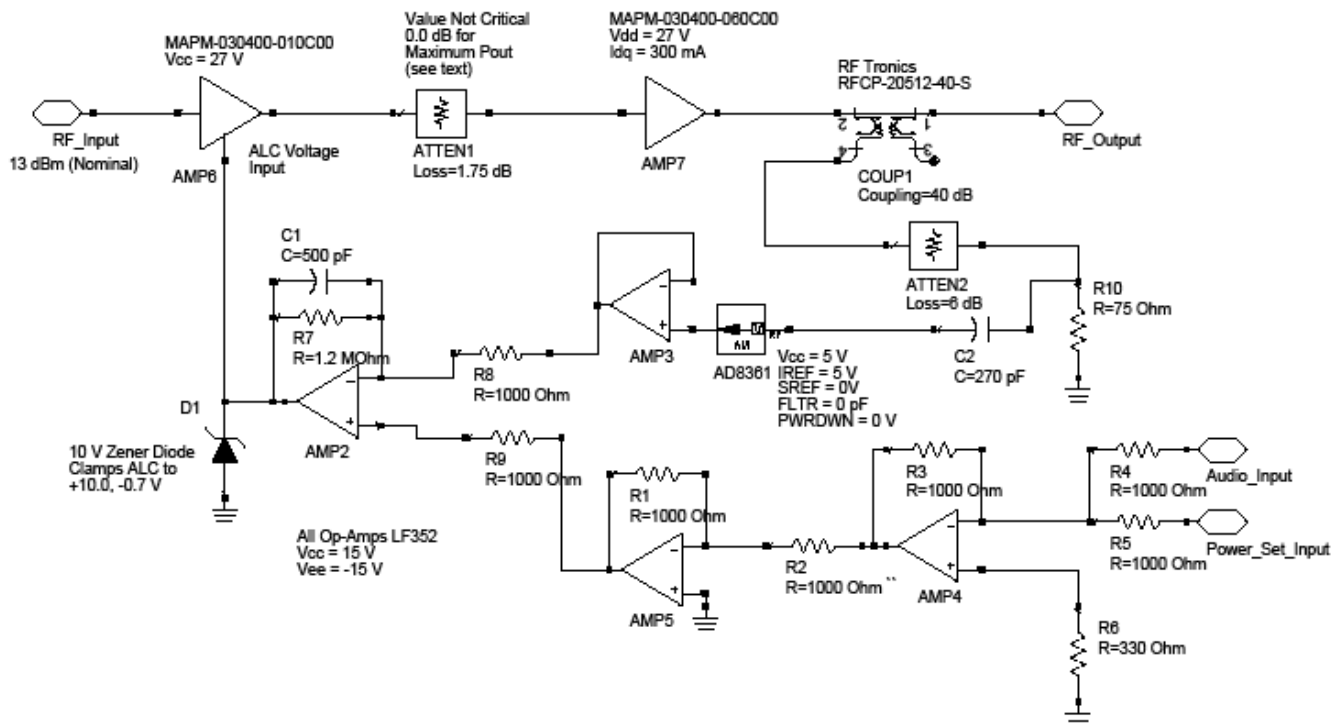

Figure 2. A practical control loop for the MAPM-modules using readily-available op-amps.

Closed Loop Control Maximizes
MAPM-030400-010C00 and MAPM-030400-060C00 Module Performance

Rev. 1

IV. Directional Coupler and Detector: Critical for Proper Loop Operation

The directional coupler and detector are the most critical parts of the control loop system – the feedback loop can generally take care of any other variations in the components. However, any variations in the coupling factor or distortion in the detected output will directly affect the RF output signal level.

The RFTronics RFCP-20512-40-S coupler chosen for this project has a very flat frequency response from 30 MHz to 400 MHz. The coupling is a nominal 40 dB, with better than +/- 0.5 dB variation across the band. The coupler is rated to handle 150 W, well below our anticipated 100 W maximum. This coupler is a dual directional coupler, and the reflected power port can be used for VSWR protection as discussed in Section VII.

The RF detector must have a response that is directly proportional to the RF waveform. Furthermore, for distortion-free AM, the detector must have a linear response. A linearly responding detector, such as the Analog Devices AD8361 chosen for this project, works quite well, even though its dynamic range is 30 dB. Residual distortion is about 2%, and much of that may have been from the function generator used in the setup. In this circuit, a 6dB pad inserted at the input avoids overdriving the detector.

If desired, a standard diode detector can be used. As an experiment, the AD8361 was replaced with a Hewlett-Packard 8473C detector. The detector buffer op amp (AMP3) was configured as an inverting amplifier with a gain of 50 dB and an input impedance of 50 ohms. While not extensively characterized, this detector provided adequate performance. A diode detector must have enough input power to drive the diode into the “linear” region, instead of the “square-law” region of operation. In our experiment, a 30 dB coupler adjusts the power to drive the detector into linear operation.

V. Closed Loop Power Control

A photograph of the system setup is shown in Figure 3. Power transfer curves similar to Figure 1 were generated. The results are shown in Figures 4 and 5. Figure 4 shows most of the frequencies overlay each other. The shape of the curve is due to the RF Voltage of the output following the Power Set Voltage. Figure 5 reveals more information. This figure shows the RF power (in dBm) vs. frequency at various Power Set voltages. The worst case flatness is 0.65 dB at a Power set voltage of 2.0 V.

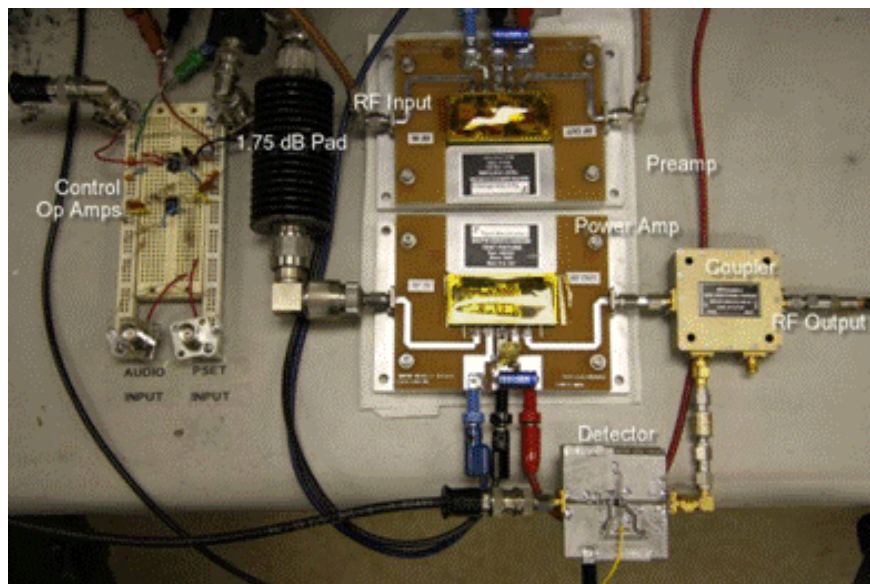

Figure 3. The completed unit using the 10W and 60W modules on their heat spreader test fixtures. The ALC loop control circuit, constructed on prototype board, is on the left.

3

Visit www.macomtech.com for additional data sheets and product information. • North America Tel: 800.366.2266 • Europe Tel: +353.21.244.6400
• India Tel: +91.80.43537383 • China Tel: +86.21.2407.1588

M/A-COM Technology Solutions Inc. and its affiliates reserve the right to make changes to the product(s) or information contained herein without notice.

www.BDTIC.com/MACOM

Closed Loop Control Maximizes
MAPM-030400-010C00 and MAPM-030400-060C00 Module Performance

Rev. 1

V. Closed Loop Power Control — Cont.

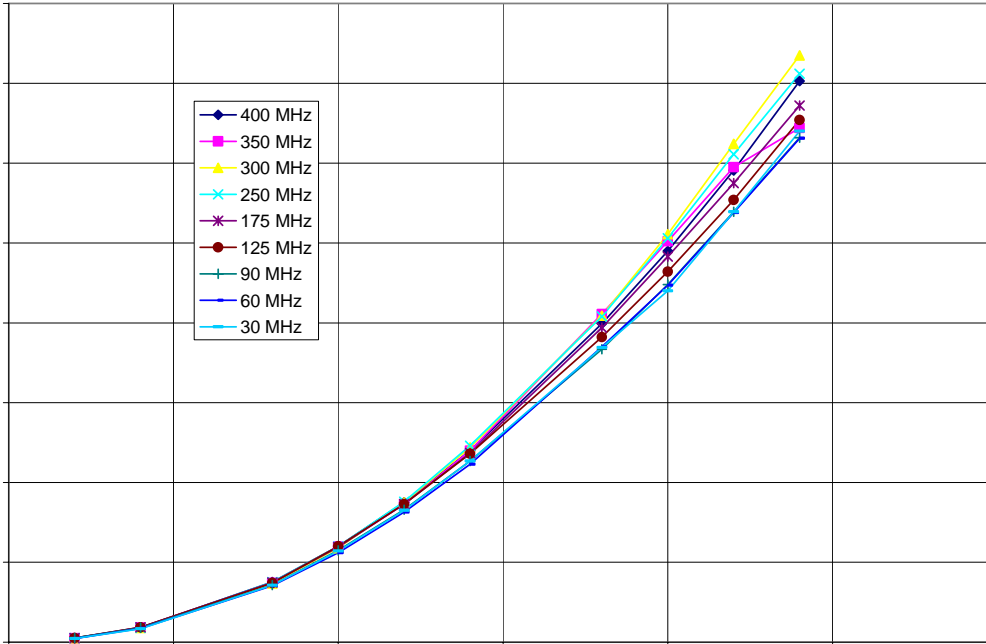
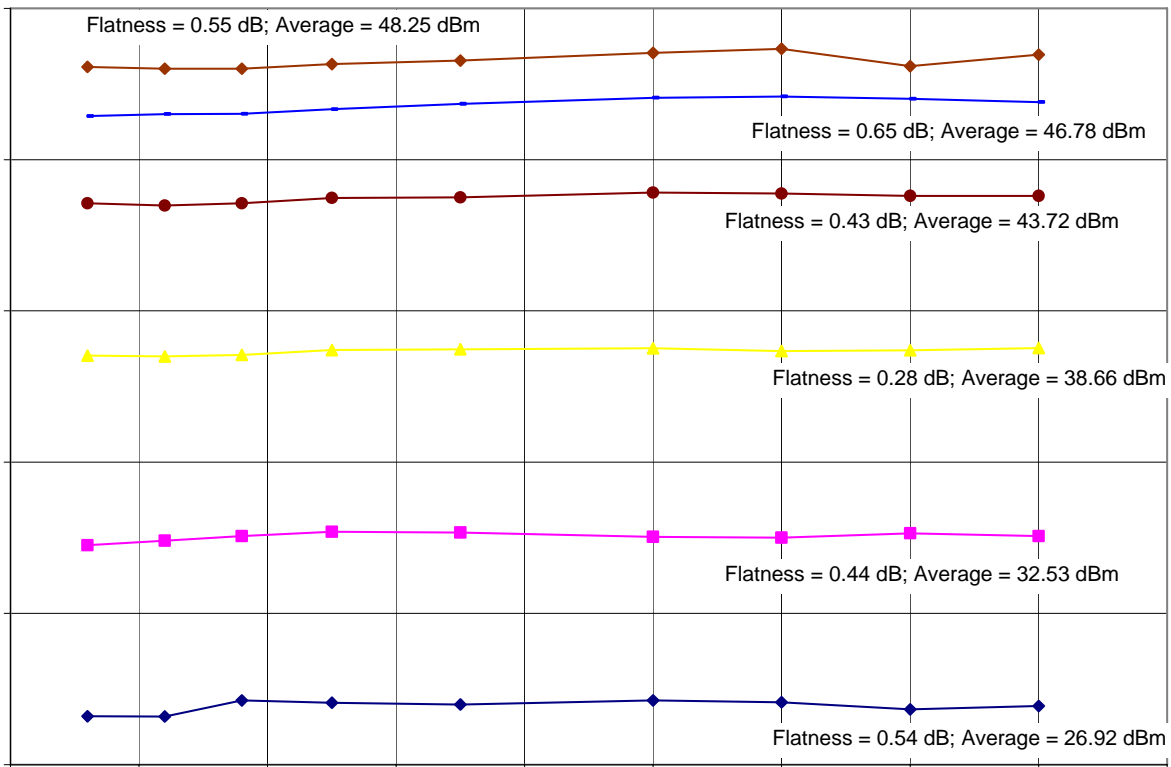

Figure 4. Initial testing of the amplifier system. The frequencies and the shape of the curve is due to the RF output voltage following the Power Set voltage.

Figure 5, below. RF power input vs. frequency at various Power Set voltages. The worst case flatness is 0.65 dB at a Power Set voltage of 2.0 V.



Closed Loop Control Maximizes
MAPM-030400-010C00 and MAPM-030400-060C00 Module Performance

Rev. 1

VI. Closed Loop Amplitude Modulation

Initial AM modulation tests at 20 W of carrier power at 400 MHz showed very good performance at 95% down modulation, see Figure 6. During initial testing at 350MHz, excessive distortion and clipping was observed. The ALC loop tried to increase power, but the amplifier is saturated.

The test was repeated without the 1.75 dB pad between the Pre Amp and Power Amp, and a better function generator was used to reduce residual distortion in the sine wave audio input signal. The results are summarized in Table I. While there was some improvement, clipping still occurred during the RF peaks at 350 MHz and 60 MHz. However, these results are very good for a broadband amplifier at 95% down modulation. The distortion at this modulation level ranged from 1.7% to 5.8%. At 350 MHz, the distortion improved to 3.9% when the modulation was reduced to 90%. At 60 MHz, the distortion improved to 2.7% at 90% down modulation. While not a design requirement for this amplifier, the AM frequency response was very good. The corner response frequency extended past 100 kHz at 90% modulation.

VII. Efficiency Improvement and Other Future Work

Table I shows that the overall DC to RF conversion efficiency of the amplifier is fairly poor at 27 V. It was no better than 31% across the band, with an average of 27 %. The last three columns of Table I show one method of improving the overall efficiency at the cost of some distortion. By lowering the DC supply voltage until the distortion reached 4%, the efficiency improved across the board at every frequency and the average was improved to 34 %. This method works by taking advantage of the control loop. Reducing the DC supply voltage lowers the saturated power. The ALC voltage increases as necessary to compensate for any difference in gain and overcome any distortion due to the compression. By operating the modules in saturation, efficiency is improved.

A practical circuit to use this technique will continually lower the supply voltage during operation. If the efficiency improving circuit senses that the ALC voltage has hit 10 V, it will quickly increase the supply voltage increasing the saturated power and decreasing the ALC voltage required. Once the ALC voltage is under 10 V, the supply voltage can be lowered again, repeating the cycle indefinitely.

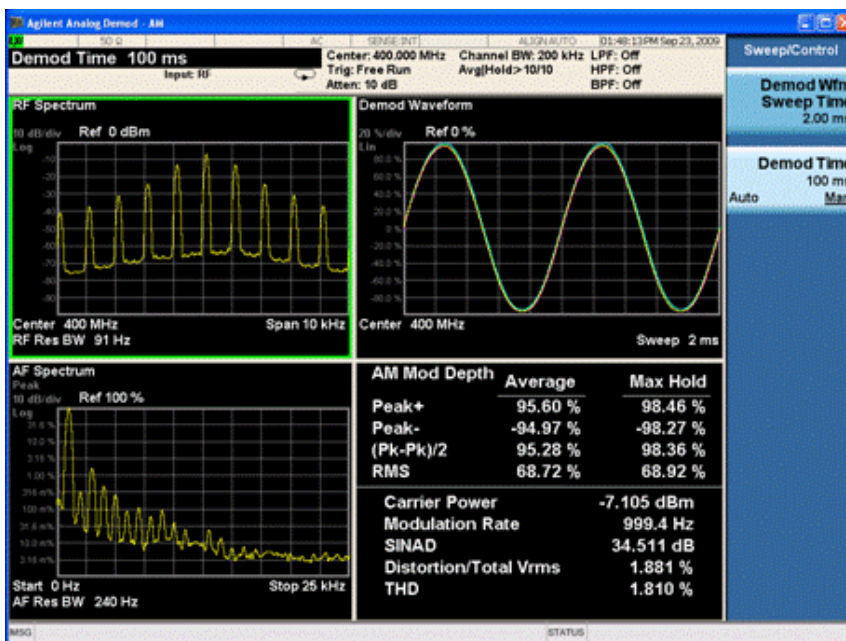

Figure 6. Good AM performance at 400 MHz with 20W of carrier power. Modulation is 95%.

**Closed Loop Control Maximizes
MAPM-030400-010C00 and MAPM-030400-060C00 Module Performance**

Rev. 1

Efficiency Improvement, Continued

Another improvement is VSWR protection. While the circuit can be set to shutdown at the presence of significant power coming from the Reverse Power port of the directional coupler, a more sophisticated approach would detect the forward and reverse power with a log-responding detector. The difference between these signals is a direct indication of the return loss, and therefore the VSWR, of the load. A protection circuit can activate at some predetermined difference in the detected voltages. By lowering the power to a safe level, the VSWR of the output load can be continually monitored and full power restored when the VSWR fault is removed.

VIII. Conclusion

An effective and practical control circuit for the MAPM-030400-010C00 driving the MAPM-030400-060C00 has been demonstrated. The circuit works well as a power leveling circuit exhibiting gain flatness of better than 0.64 dB over the 30 to 400 MHz band. It also functions as an AM modulator with distortion better than 6% at 95% down modulation. This circuit can be the basis of a basic radio transmitter over the communication bands in the 30 MHz to 400 MHz VHF and UHF frequency spectrum.

References

- [1] H.Krauss, C. Bostian, F. Raab, *Solid State Radio Engineering*, John Wiley and Sons, 1980
- [2] N. Dye, H. Granberg, *Radio Frequency Transistors: Principles and Practical Applications*, Butterworth-Heinemann, 1993
- [3] J. Millman, *Microelectronics: Digital and Analog Circuits and Systems*, McGraw-Hill, 1979
- [4] National Semiconductor, AN-20: "An Applications Guide for Op Amps," 1969 (Re-released 2009) <http://www.national.com/an/AN/AN-20.pdf>
- [5] Analog Devices, AD8361 Datasheet
- [6] Analog Devices, AD8362 Datasheet

TABLE I
CLOSED LOOP AM PERFORMANCE

Carrier Frequency (MHz)	Carrier Power (W)	Power Set Setting (V)	Audio Setting (Vpk-pk)	AM Distortion (%)	27 V Current (A avg)	27 V Efficiency (%)	4% Dist Voltage (V)	4% Dist Current (A avg)	4% Dist Efficiency (%)
400	20.0	1.28	1.352	1.7	4.4	25	24.5	4.5	27
350	20.0	1.27	1.352	5.8	4.3	24	N/A	N/A	N/A
300	20.0	1.25	1.322	1.9	3.9	28	22.2	4.0	32
250	20.0	1.25	1.298	1.9	4.4	24	20.3	4.7	29
175	20.0	1.27	1.333	2.4	3.8	28	18.0	4.1	38
125	20.0	1.28	1.346	1.8	3.8	28	17.7	4.1	37
90	20.0	1.30	1.354	2.7	3.4	31	17.6	3.5	44
60	20.0	1.29	1.338	4.3	3.6	29	N/A	N/A	N/A
30	20.0	1.28	1.323	2.8	4.0	26	23.6	4.0	30

Notes: Input Power fixed at 13 dBm. Idq for Power Amp set to 300 mA
At 90% modulation, the distortion at 350 MHz improved to 3.9%;
At 90% modulation, the distortion at 60 MHz improved to 2.7%