

# Using a 2450BM14A0002 Balun with nRF24LE1 QFN32

nAN24-17

Application Note v1.0

All rights reserved.

Reproduction in whole or in part is prohibited without the prior written permission of the copyright holder.

2011-05-18

---

## Contents

<b>1</b>	<b>Introduction .....</b>	<b>3</b>
<b>2</b>	<b>Antenna matching network overview .....</b>	<b>4</b>
<b>3</b>	<b>Implementation .....</b>	<b>5</b>
3.1	Schematic .....	5
3.2	Layout .....	5
3.3	Measurement results on the 2450BM14A0002 balun .....	6
<b>4</b>	<b>Conclusion .....</b>	<b>10</b>

---

## 1 Introduction

This application note describes how to use Johanson Technology's 2450BM14A0002 balun (an SMD six-pin device with a small footprint of 1.6x0.8 mm (EIA 0603)) with the nRF24LE1 QFN32.

The 2450BM14A0002 balun greatly simplifies the RF front-end by considerably reducing component count, system variability, implementation size area, and PCB sensitivity. Johanson Technology's 2450BM14A0002 balun was originally designed for the nRF24L01(+) transceivers, and a technical note on how to use it with nRF24L01(+) can be downloaded from Johanson Technology's website (<http://www.johansontechnology.com/en/technical-notes.html>)

Since nRF24LE1 uses nRF24L01+ as its radio core, it means the 2450BM14A0002 balun can also be used on some of the nRF24LE1 variants.

nRF24LE1 has a different packet size to the nRF24L01(+) standalone chips, so the length of the bonding wires is different. This means the impedance load on the antenna pins is different for nRF24LE1 when compared to nRF24L01(+). This application note describes how to compensate for this difference.

**Note:** This application note does not apply to nRF24LE1 QFN24 or nRF24LE1 QFN48. The 2450BM14A0002 balun is not suitable for these devices because of the different packet sizes.

## 2 Antenna matching network overview

The antenna matching network has four main tasks:

- Balanced to unbalanced transformation (balun)
- Impedance transformation from a high impedance PA (Power Amplifier) load to 50  $\Omega$
- Low pass filtering to suppress harmonics
- Power supply feed to the PA

All these tasks are handled by the antenna matching network's three inductors and three capacitors, see [Figure 1](#). The layout is critical since parasitic capacitance and inductance can be high.

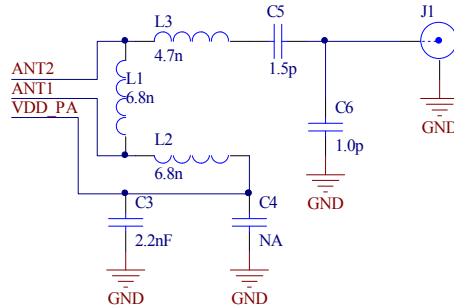

Figure 1. Standard antenna matching network

If space is limited, you can replace the antenna matching network with a single component; an integrated balun. This performs the same tasks as the discrete balun, but with a single component only.

### 3 Implementation

The balun replaces all RF components in the antenna matching network and performs the same tasks as the antenna matching network (see [Figure 1. on page 4](#)) but with reduced space requirements.

#### 3.1 Schematic

The schematic of the nRF24LE1 QFN32 and the 2450BM14A0002 balun are shown in [Figure 2.](#)

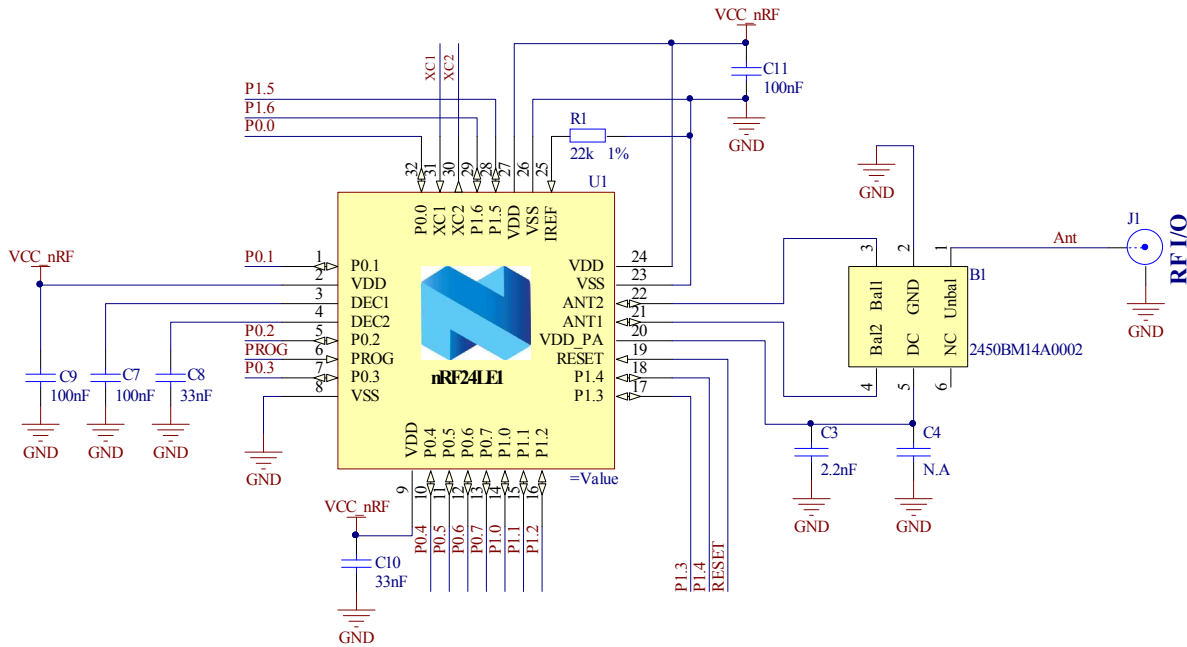

Figure 2. nRF24LE1 QFN32 schematic and the balun

The capacitor C3 (2.2nF) is needed to filter and decouple the power supply to the PA. All other matching network components are replaced by the balun B1. You can connect the 50  $\Omega$  unbalanced output directly to a 50  $\Omega$  antenna, or to the antenna match.

#### 3.2 Layout

The nRF24LE1 QFN32 has shorter internal bonding wires than nRF24L01(+), so to compensate for this difference, the balun is placed 2.34 mm away from nRF24LE1. This is a longer distance than used for the nRF24L01(+) standalone chipsets and this extra length increases the inductance of the tracks from the ANT1 and ANT2 pins to the balun, creating a more optimal load for nRF24LE1. See [Figure 3. on page 6](#).

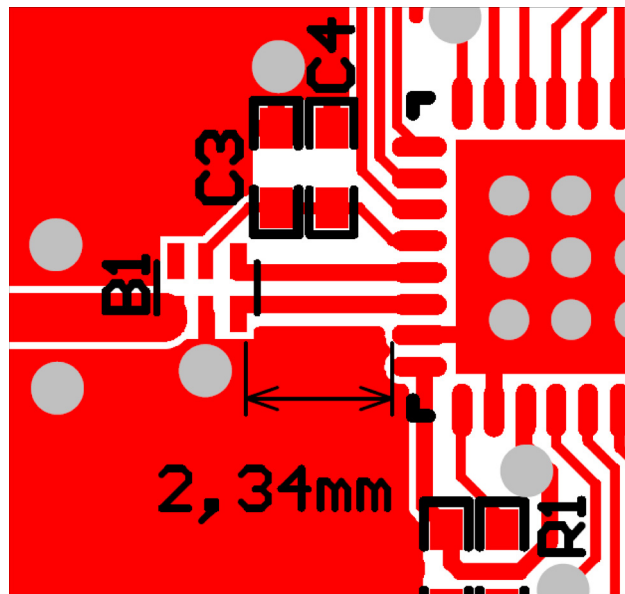

Figure 3. Balun layout

**Note:** The distance is measured from the edge of the nRF24LE1 pad to the edge of the balun pad.

### 3.3 Measurement results on the 2450BM14A0002 balun

[Figure 4. on page 7](#) shows the output power, measured on the 50  $\Omega$  unbalanced port on the balun. The carrier is swept across the 2.4 GHz band (markers are placed at 2.40 GHz, 2.44 GHz and 2.48 GHz). [Figure 5. on page 7](#) to [Figure 7. on page 8](#) shows the harmonic components (markers are placed at maximum power). [Figure 8. on page 9](#) shows the LO leakage in RX mode (a marker is placed at the maximum power).

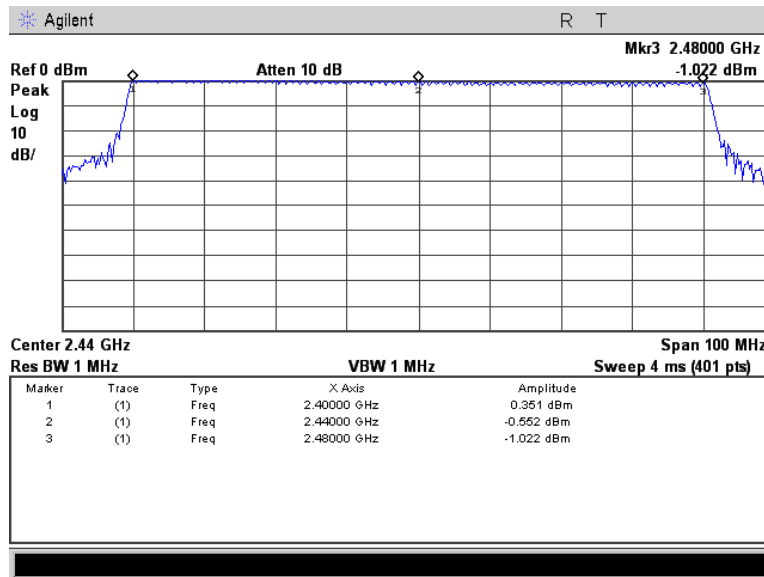

Figure 4. Output power, carrier sweep

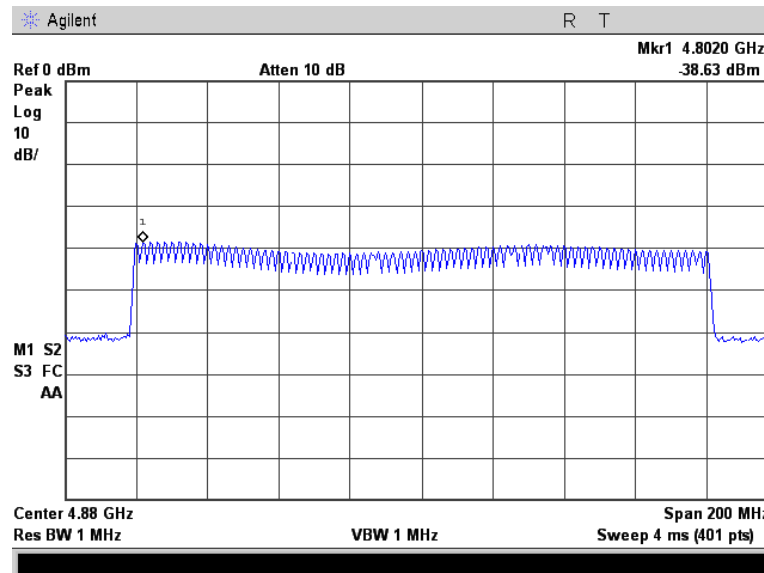

Figure 5. 2nd harmonic, carrier sweep

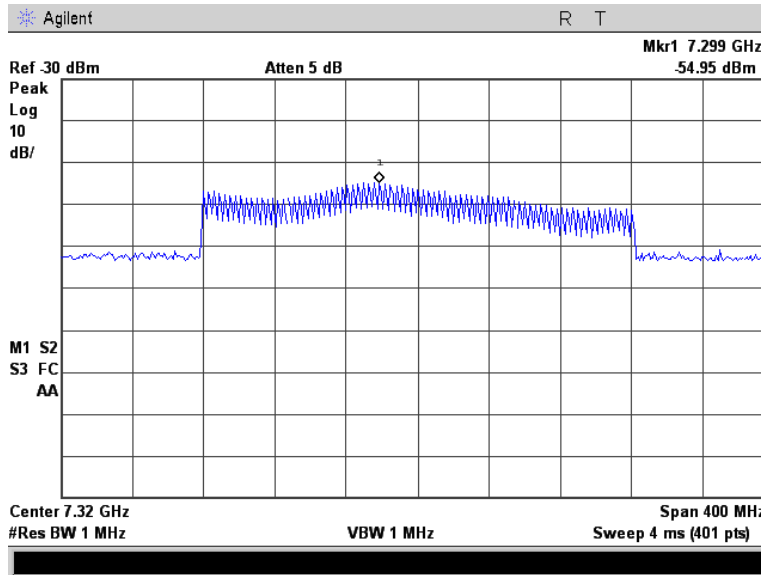

Figure 6. 3rd harmonic, carrier sweep

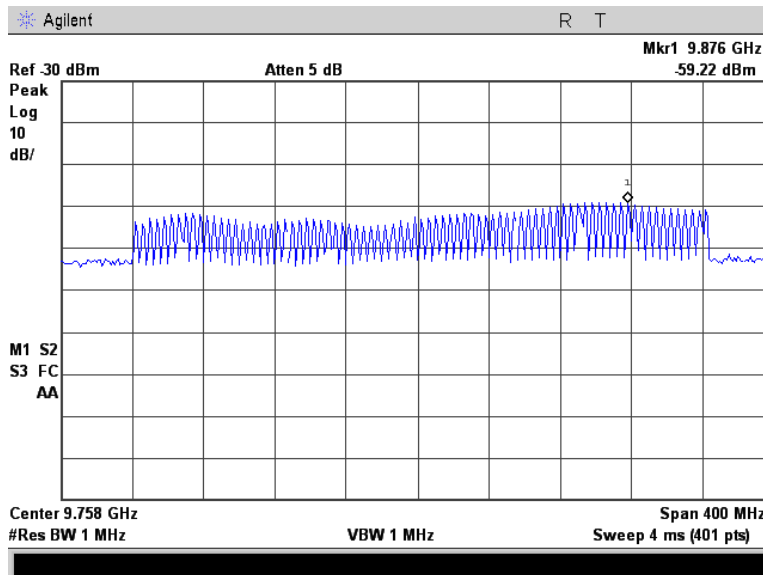

Figure 7. 4th harmonic, carrier sweep



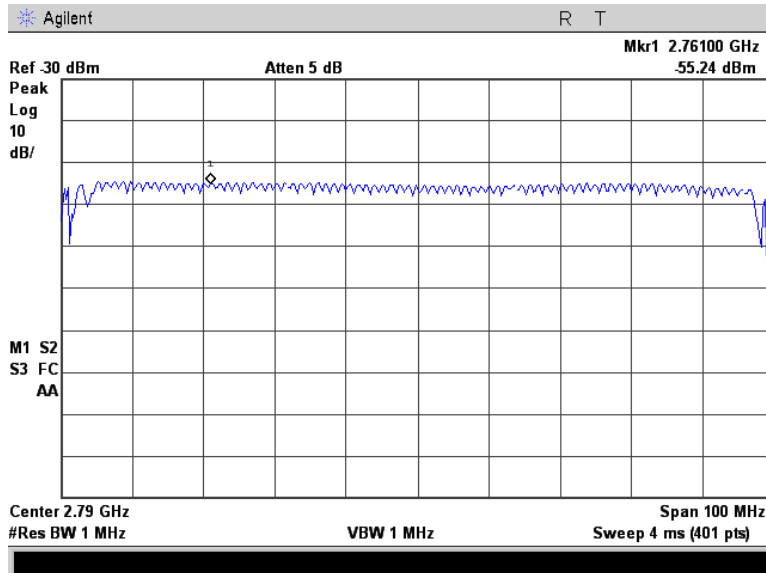

Figure 8. RX LO, channel sweep

Frequency (GHz)	Measurement level (dBm)	Pass ETSI/FCC?
2.40	0.351	Yes
2.44	-0.552	Yes
2.48	-1.022	Yes

Table 1. Output power levels on the 2450BM14A0002 balun

Name	Frequency (GHz)	Measurement level (dBm)	Pass ETSI/FCC?
2nd harmonic	4.802	-38.63	Yes
3rd harmonic	7.299	-54.95	Yes
4th harmonic	9.876	-59.22	Yes
RX LO	2.761	-55.24	Yes

Table 2. Harmonics and RX LO levels on the 2450BM14A0002 balun

## 4 Conclusion

As the measurement results show (see [Table 2. on page 9](#)), the output power is close to 0 dBm across the band. The harmonics are well below the regulation limits for the ETSI and FCC regulatory standards and so is the spurious in RX mode.

The discrete antenna matching network has similar measurement results:

Frequency (GHz)	Measurement level (dBm)	Pass ETSI/FCC?
2.400	0.3	Yes
2.480	-0.6	Yes

*Table 3. Output power levels on the discrete antenna matching network*

Name	Frequency (GHz)	Measurement level (dBm)	Pass ETSI/FCC?
2nd harmonic	4.802	-44.8	Yes
3rd harmonic	7.299	-54.9	Yes
4th harmonic	9.876	-51	Yes
RX LO	2.761	-57.4	Yes

*Table 4. Harmonics and RX LO levels on the discrete antenna matching network*

These measurement results prove that the discrete balun can be replaced with an integrated balun without any performance loss.

## Liability disclaimer

Nordic Semiconductor ASA reserves the right to make changes without further notice to the product to improve reliability, function or design. Nordic Semiconductor ASA does not assume any liability arising out of the application or use of any product or circuits described herein.

## Life support applications

Nordic Semiconductor's products are not designed for use in life support appliances, devices, or systems where malfunction of these products can reasonably be expected to result in personal injury. Nordic Semiconductor ASA customers using or selling these products for use in such applications do so at their own risk and agree to fully indemnify Nordic Semiconductor ASA for any damages resulting from such improper use or sale.

## Contact details

For your nearest dealer, please see <http://www.nordicsemi.com>

Receive available updates automatically by subscribing to eNews from our homepage or check our website regularly for any available updates.

### Main office:

Otto Nielsens veg 12  
7004 Trondheim  
Phone: +47 72 89 89 00  
Fax: +47 72 89 89 89  
[www.nordicsemi.com](http://www.nordicsemi.com)



## Revision History

Date	Version	Description
May 2011	1.0	