



TS4871 low voltage audio power amplifier Evaluation board user guidelines

Features

- TS4871 low voltage audio power amplifier with active low standby mode
- Operating range from $V_{CC}=2.2V$ to $5.5V$
- 1W output power @ $V_{CC}=5V$, THD=1%, $F=1kHz$, with 8Ω load
- Ultra low power consumption in standby mode (10nA)
- 75dB PSRR @ 217Hz in grounded mode ($A_v=2V/V$)
- Near zero pop & click
- Ultra low distortion (0.1%)
- Module gain set at $2V/V$
- Thermal and short-circuit protection

Description

DEMO TS4871 is an evaluation board designed for the TS4871 low power audio amplifier. The micropackage DFN8 (dual flat non leaded 8 pins) allows space saving and good thermal dissipation.

The BTL gain is set at $2V/V$ and can be adapted if necessary with a modification of R1 or R2 values.

On the board, the R3 and C3 component locations are empty to allow you to modify the input configuration from single-ended to differential. For differential mode, R4 must be modified.

The C1 component location is also empty in order to add a low pass filter if required.

For more detailed information about component calculation, refer to the TS4871 datasheet.

1 Evaluation board connector configuration

Connectors	Description
Cn1	Power connector (V_{CC} and GND). Power supply voltage from 2.2V to 5.5V.
Cn2 and Cn3	Input signal connector (GND and active input signal).
Cn4	Output signal connector (V_{out1} and V_{out2})
Cn5	Standby control connector (GND, Standby, V_{CC}). A short-circuit between GND and Standby puts U1 in standby mode. A short-circuit between V_{CC} and standby puts U1 in operation mode.

Caution: When you apply power supply through Cn1, DO NOT invert the polarity because it would destroy the amplifier U1.

2 Schematic diagram

Figure 1. Schematic diagram of the TS4871 DFN8

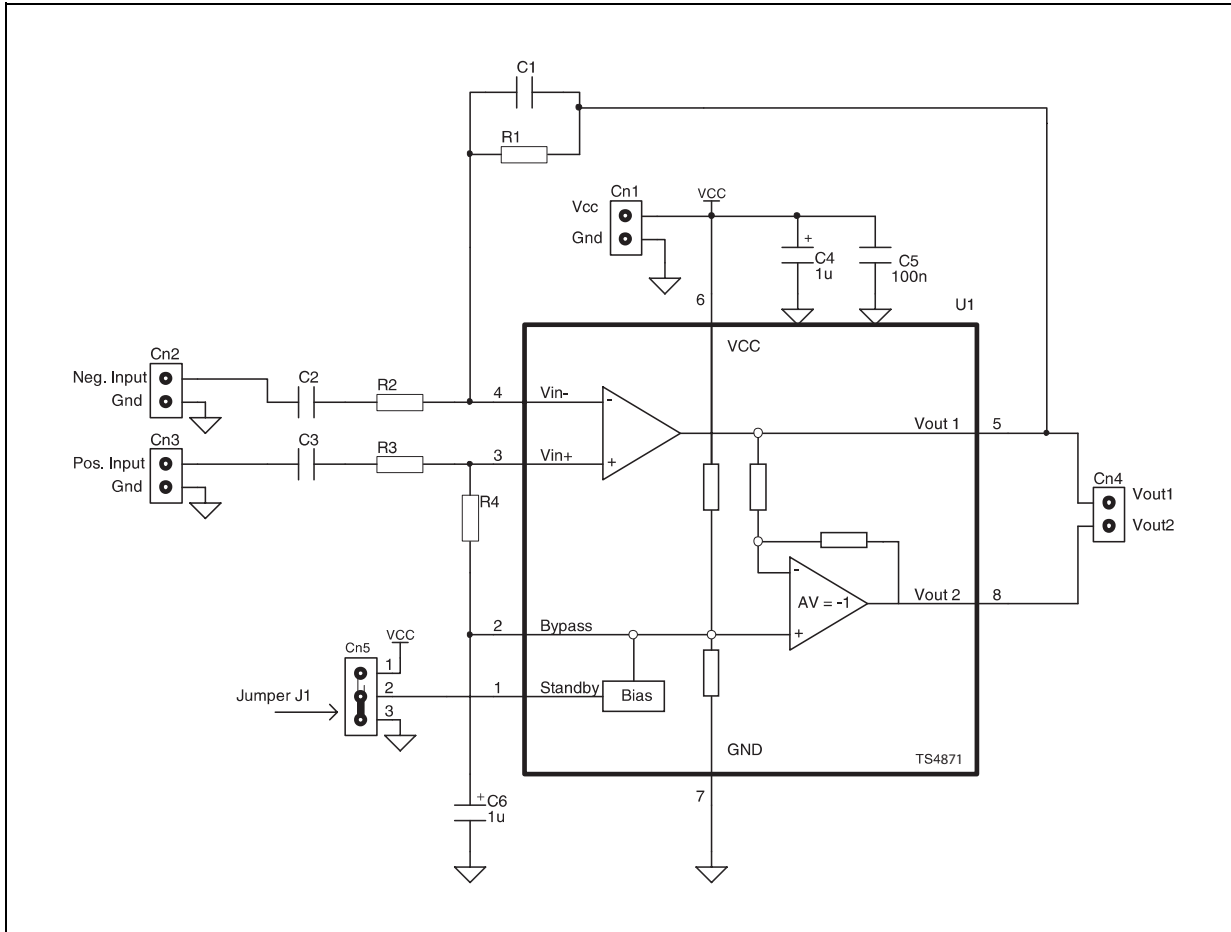

Table 1. Component list for the DEMO TS4871/DFN

Designation	Quantity	Description
C1	0	Unconnected, ceramic capacitors, 0603
C2	1	100nF/16V, ceramic capacitors, 0603
C3	0	Unconnected, ceramic capacitors, 0603
C4	1	1 μ F/50V, electrolytic capacitor
C5	1	100nF/16V, ceramic capacitors, 0603
C6	1	1 μ F/50V, electrolytic capacitor
Cn1	1	2 pins header 2.54mm pitch
Cn2	1	2 pins header 2.54mm pitch
Cn3	1	2 pins header 2.54mm pitch
Cn4	1	2 pins header 2.54mm pitch
Cn5	1	3 pins header 2.54mm pitch
J1	1	Jumper, 2.54mm pitch
R1	1	22k, 1/16W 1% resistor, 0603
R2	1	22k, 1/16W 1% resistor, 0603
R3	0	Unconnected, 1/16W 1% resistor, 0603
R4	1	0R, 1/16W 1% resistor, 0603
U1	1	TS4871IQ (DFN8 package)

3 Evaluation board layout

The following figures show the layers and the top view of the TS4871 demoboard.

Figure 2. PCB top layer

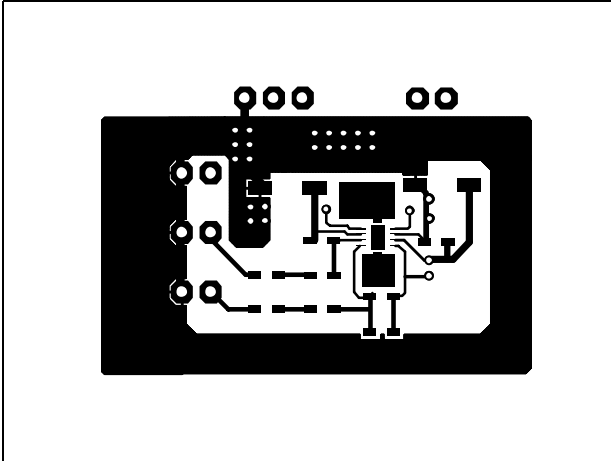

Figure 3. PCB bottom layer

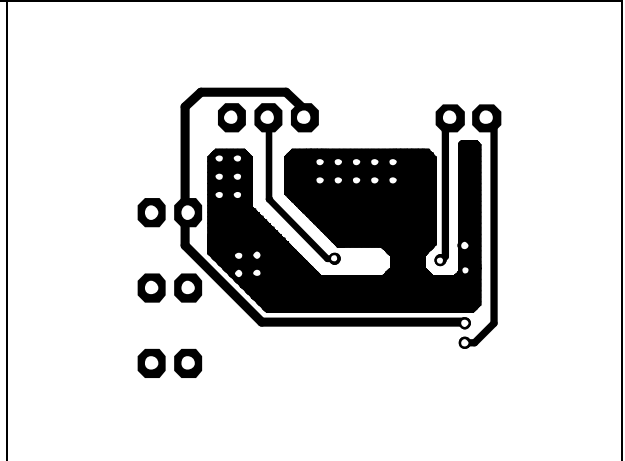
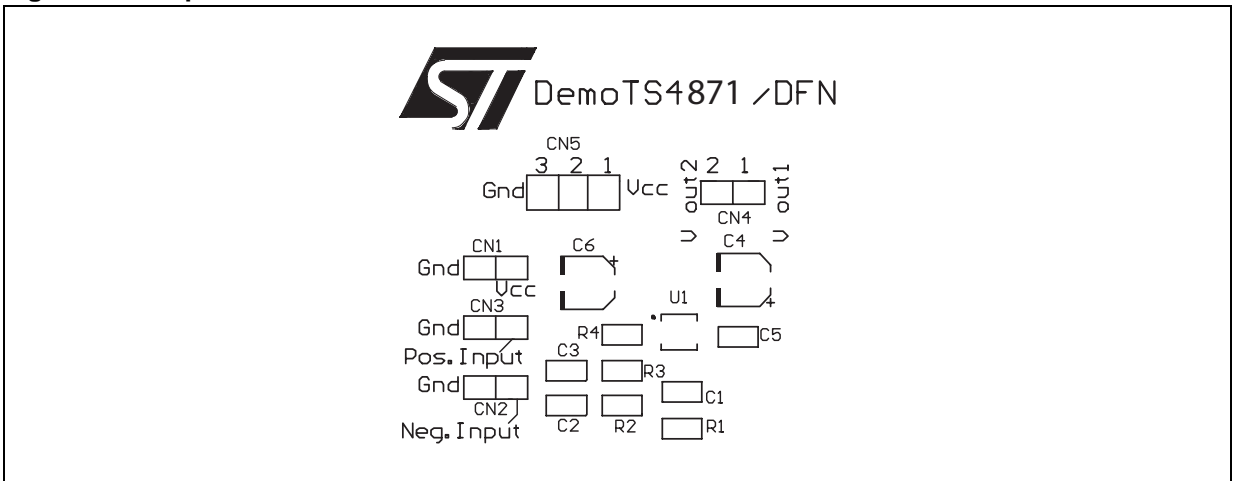

Figure 4. Top view of demoboard



Please Read Carefully:

Information in this document is provided solely in connection with ST products. STMicroelectronics NV and its subsidiaries ("ST") reserve the right to make changes, corrections, modifications or improvements, to this document, and the products and services described herein at any time, without notice.

All ST products are sold pursuant to ST's terms and conditions of sale.

Purchasers are solely responsible for the choice, selection and use of the ST products and services described herein, and ST assumes no liability whatsoever relating to the choice, selection or use of the ST products and services described herein.

No license, express or implied, by estoppel or otherwise, to any intellectual property rights is granted under this document. If any part of this document refers to any third party products or services it shall not be deemed a license grant by ST for the use of such third party products or services, or any intellectual property contained therein or considered as a warranty covering the use in any manner whatsoever of such third party products or services or any intellectual property contained therein.

UNLESS OTHERWISE SET FORTH IN ST'S TERMS AND CONDITIONS OF SALE ST DISCLAIMS ANY EXPRESS OR IMPLIED WARRANTY WITH RESPECT TO THE USE AND/OR SALE OF ST PRODUCTS INCLUDING WITHOUT LIMITATION IMPLIED WARRANTIES OF MERCHANTABILITY, FITNESS FOR A PARTICULAR PURPOSE (AND THEIR EQUIVALENTS UNDER THE LAWS OF ANY JURISDICTION), OR INFRINGEMENT OF ANY PATENT, COPYRIGHT OR OTHER INTELLECTUAL PROPERTY RIGHT.

UNLESS EXPRESSLY APPROVED IN WRITING BY AN AUTHORIZED ST REPRESENTATIVE, ST PRODUCTS ARE NOT RECOMMENDED, AUTHORIZED OR WARRANTED FOR USE IN MILITARY, AIR CRAFT, SPACE, LIFE SAVING, OR LIFE SUSTAINING APPLICATIONS, NOR IN PRODUCTS OR SYSTEMS WHERE FAILURE OR MALFUNCTION MAY RESULT IN PERSONAL INJURY, DEATH, OR SEVERE PROPERTY OR ENVIRONMENTAL DAMAGE. ST PRODUCTS WHICH ARE NOT SPECIFIED AS "AUTOMOTIVE GRADE" MAY ONLY BE USED IN AUTOMOTIVE APPLICATIONS AT USER'S OWN RISK.

Resale of ST products with provisions different from the statements and/or technical features set forth in this document shall immediately void any warranty granted by ST for the ST product or service described herein and shall not create or extend in any manner whatsoever, any liability of ST.

ST and the ST logo are trademarks or registered trademarks of ST in various countries.

Information in this document supersedes and replaces all information previously supplied.

The ST logo is a registered trademark of STMicroelectronics. All other names are the property of their respective owners.

© 2006 STMicroelectronics - All rights reserved

STMicroelectronics group of companies

Australia - Belgium - Brazil - Canada - China - Czech Republic - Finland - France - Germany - Hong Kong - India - Israel - Italy - Japan - Malaysia - Malta - Morocco - Singapore - Spain - Sweden - Switzerland - United Kingdom - United States of America

www.st.com