

TSH173 triple video buffer with filter for SD video evaluation board user guidelines

Introduction

This application note describes the TSH173 evaluation board, designed to help you evaluate the TSH173 triple video buffer.

This document includes:

- A short description of the TSH173 video buffer, including the internal block diagram
- A description of the evaluation board and all of its components
- The layout of the evaluation board

About the TSH173

The TSH173 is a single supply triple video buffer featuring an internal gain of 6dB and an internal low pass filter of 8.2MHz cut-off frequency for each channel to fit with Standard Definition requirements for video line interfaces.

Figure 1. TSH173 evaluation board



Main features of the TSH173

- 4.5V to 5.5V single supply operation
- R-G-B, Y-Pb-Pr, Y-C-CVBS driving
- 3 channels with 6dB gain buffer
- 3 video reconstruction filters for SD
- 3 internal input DC level shifter
- No input capacitor required
- Very low harmonic distortion
- Each output can drive AC- or DC-coupled 150Ω loads
- Tested on 5V power supply

1 TSH173 description

Figure 2. TSH173 internal block diagram

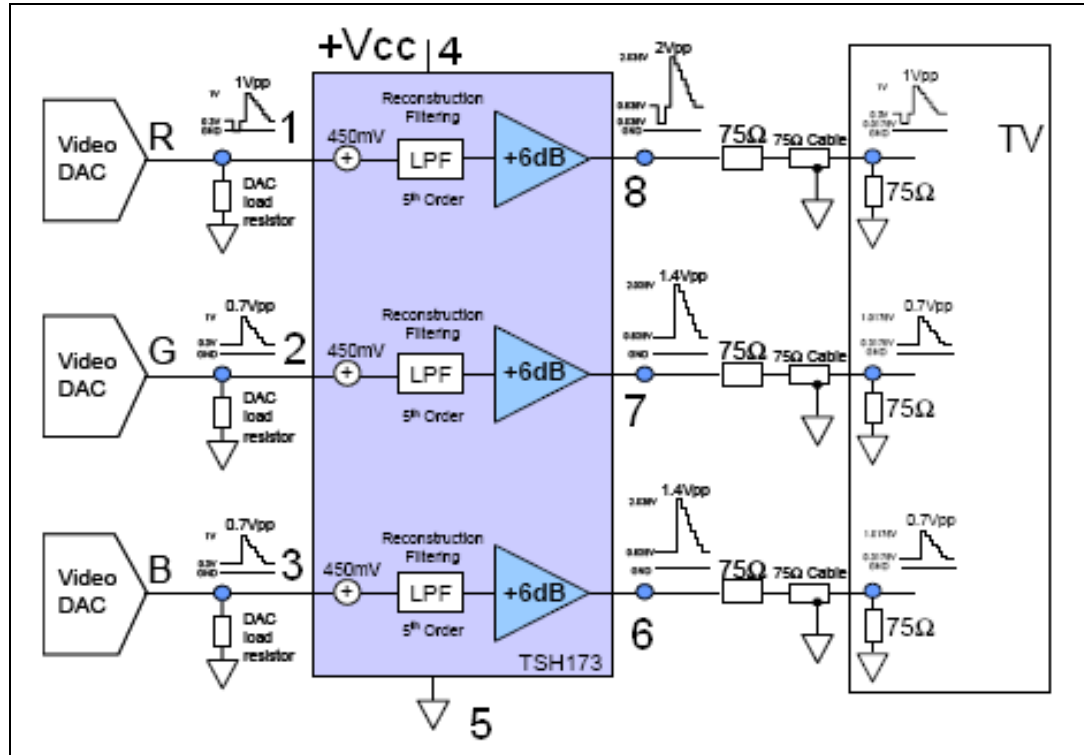

Table 1. Pin description

Name	Pin number	Description
IN1, IN2, IN3	1, 2, 3	Input pins
OUT1, OUT2, OUT3	8, 7, 6	Output pins
+VCC	4	Positive supply
GND	5	Ground

2 Evaluation board description

This board is designed to be tested with a 75Ω generator and 75Ω measurement tool.

Input signal must be between 0V and 1.4V so that it is not clamped. Otherwise, you must replace the zero ohm resistor by a 100nF capacitor in CR1, CR2, and CR3, and add a resistor bridge to polarize the input signal at the right level as shown in [Figure 3](#). Resistor bridge footprints are located on the back of the PCB.

Figure 3. TSH173 input

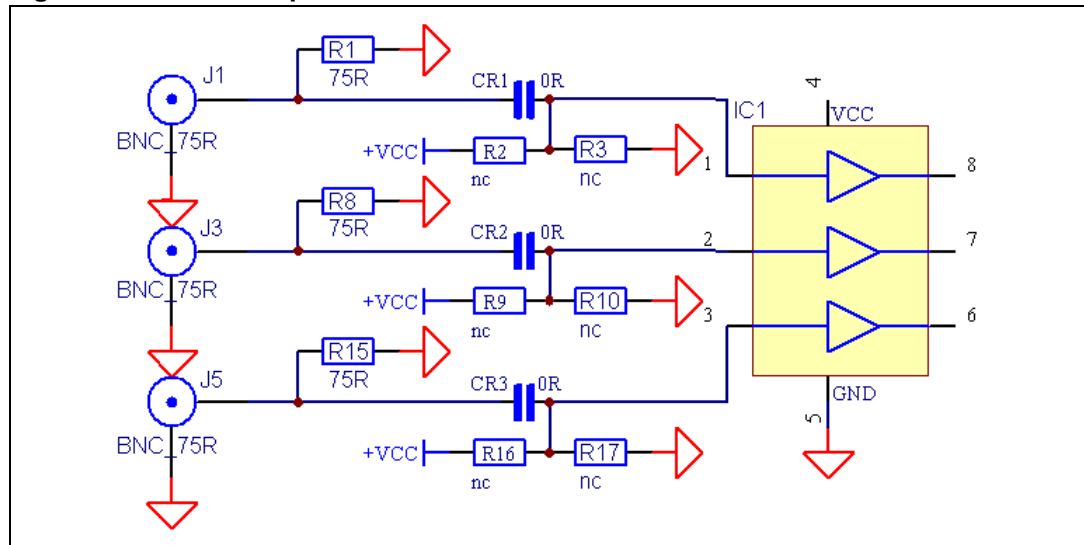

The TSH173 output can be AC coupled by a 220nF capacitor to minimize the DC component on the line. To do this, you must remove the R4, R11, and R18 zero ohm resistors and solder a 220μF capacitor on C6, C8, and C10 footprints as shown in [Figure 4](#).

Figure 4. TSH173 AC output

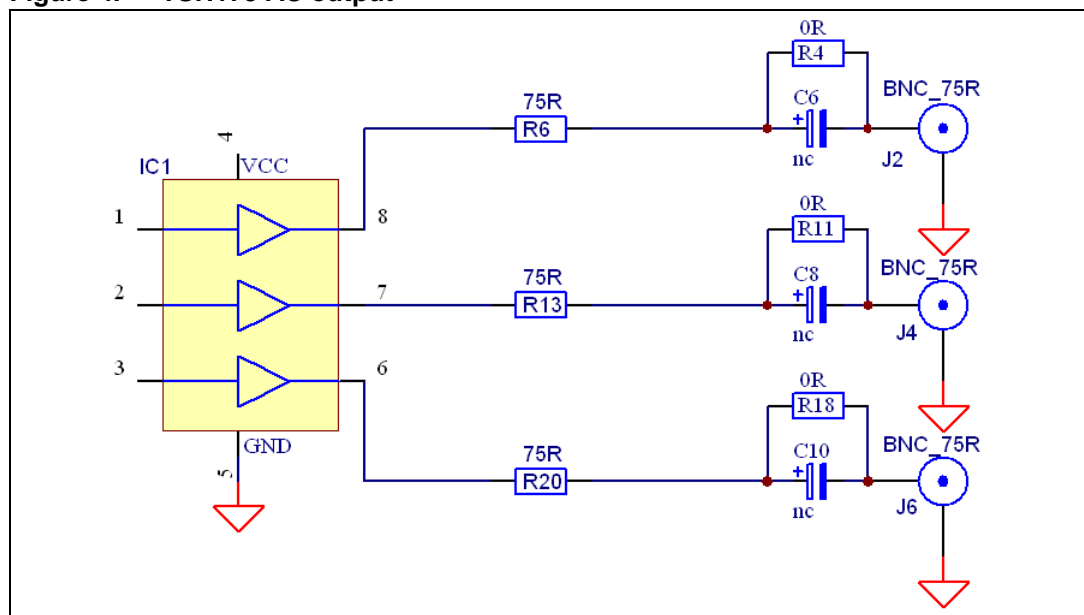

If you connect a system with an input impedance other than 75Ω to the PCB output, a Π resistor footprint on the board allows you to match impedances.

For example: you connect a scope with a 50Ω output impedance. To match impedances, you must add the following resistors: R5=2.2kΩ, R6=130Ω, R7=82Ω

The output can be AC or DC connected with this configuration.

Figure 5. TSH173 output impedance matching

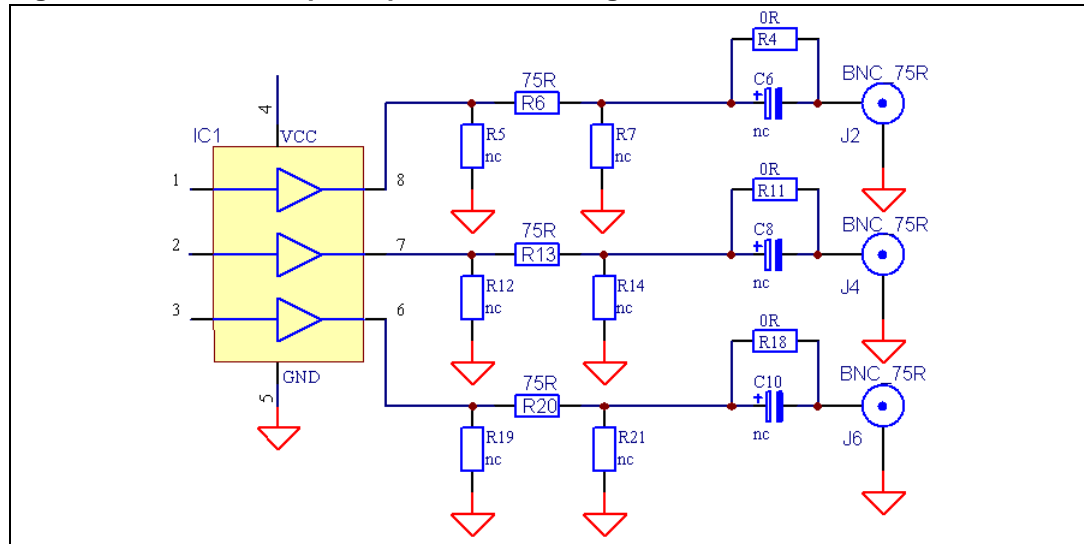

Power supply

Correct power supply bypassing is very important for optimizing performance. A 10μF and a 100nF are soldered on the board. This gives good performance. However, you can improve it by adding a 100μF capacitor in C3 and placing a 560μH coil instead of the zero ohm resistor in LR1.

Figure 6. Power supply

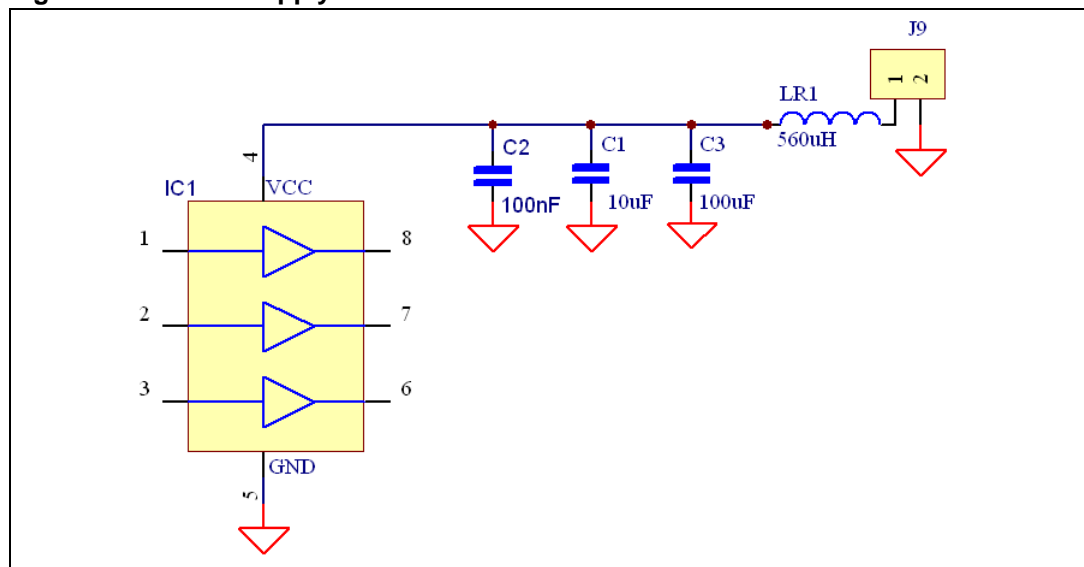

3 Schematic diagram and board components

Figure 7. Board components

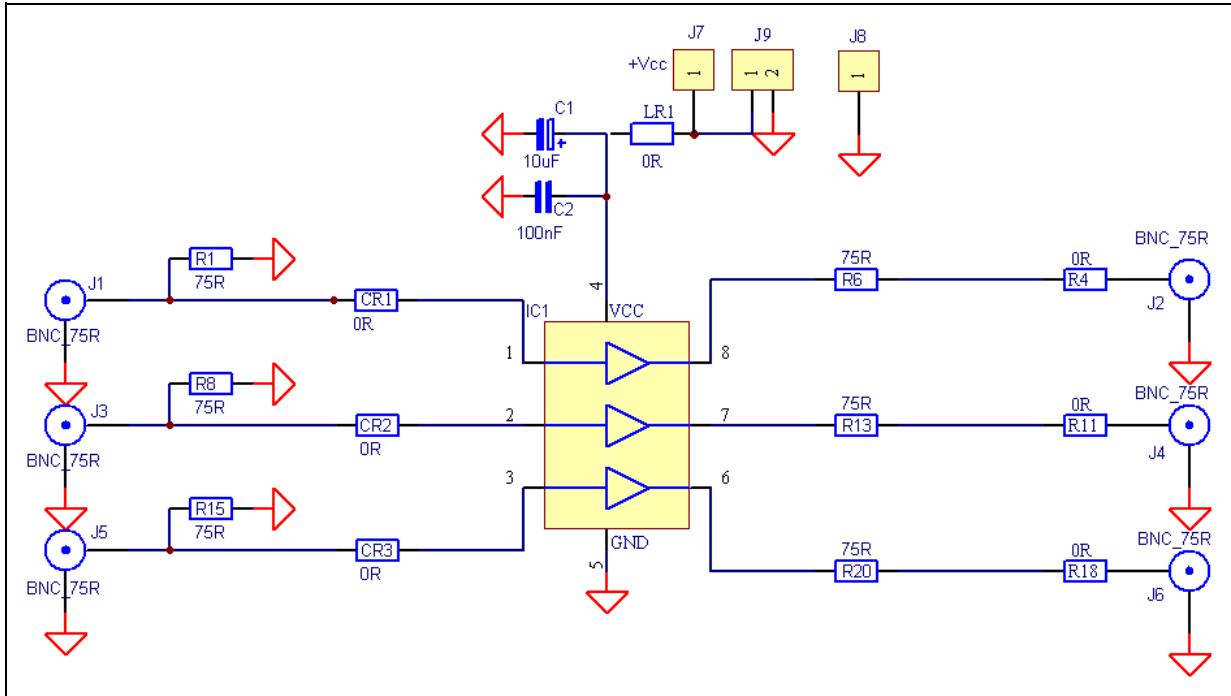

Figure 8. Full layout schematics

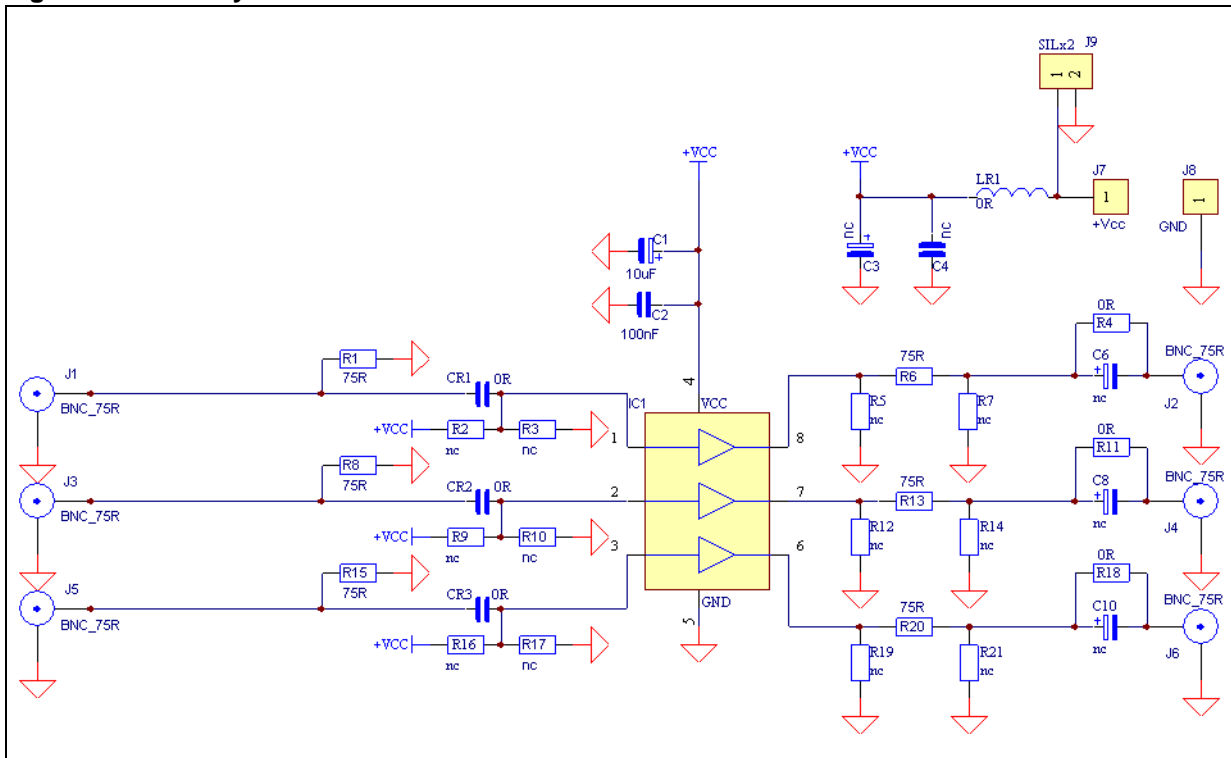

Table 2. List of board components

Part type	Name on board	Footprint	Description
10 μ F	C1	1206	Bypass ceramic capacitor on V_{CC}
100 μ F	C2	0805	Bypass ceramic capacitor on V_{CC}
	C3	8mm diameter	Bypass chemical capacitor on V_{CC} not connected
	C4	0805	Bypass ceramic capacitor on V_{CC} not connected
0 ohm	CR1, CR2, CR3	0805	Input capacitor replaced by a 0 ohm resistor
	C6,C8,C10		Output capacitor 220 μ F not connected
TSH173	IC1	SO8	
BNC 75 Ω	J1, J3, J5	BNC	Input signal connectors
BNC 75 Ω	J2, J4, J6	BNC	Output signal connectors
JACK	J7, J8		Jack 2mm supply connectors
SIL	J9	SIL	SIL supply connector 2.54mm pitch
0 ohm	LR1	1206	Coil replaced by 0 ohm resistor
75 Ω	R1, R8, R15	0805	input resistor
75 Ω	R6, R13, R20	0805	output resistor
	R2, R3, R9, R10, R16, R17	0805	Bridge resistors not connected
0 ohm	R4, R11, R18	0805	Strap when output is DC coupled
	R5, R7, R12, R14, R19, R21	0805	Optional resistors to adapt output impedance

4 PCB layout

Figure 9. Top layer

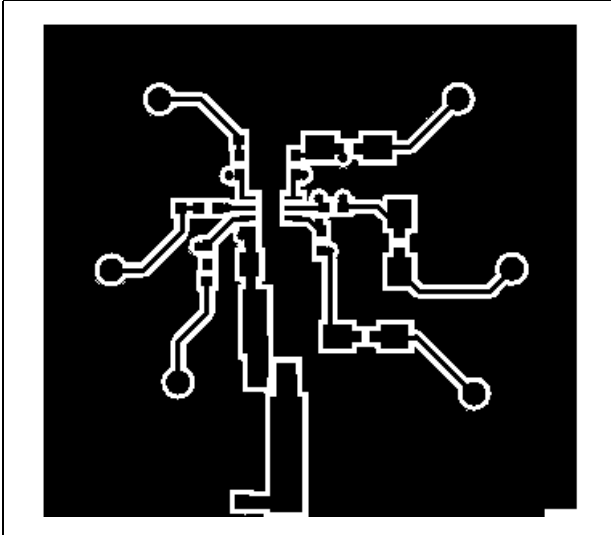

Figure 10. Top layout

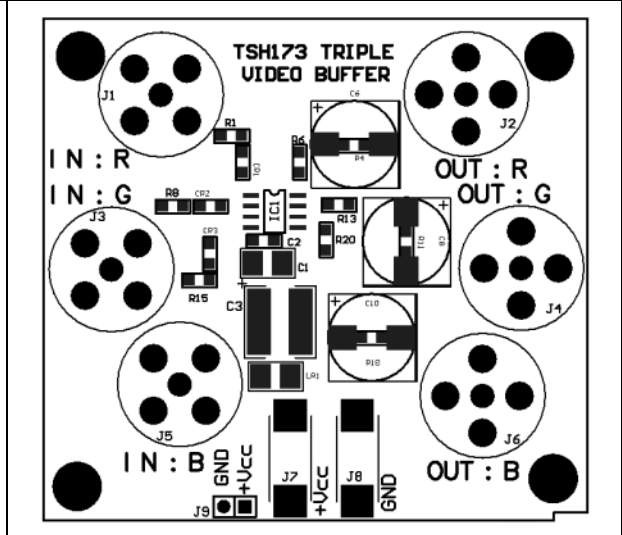

Figure 11. Bottom layer

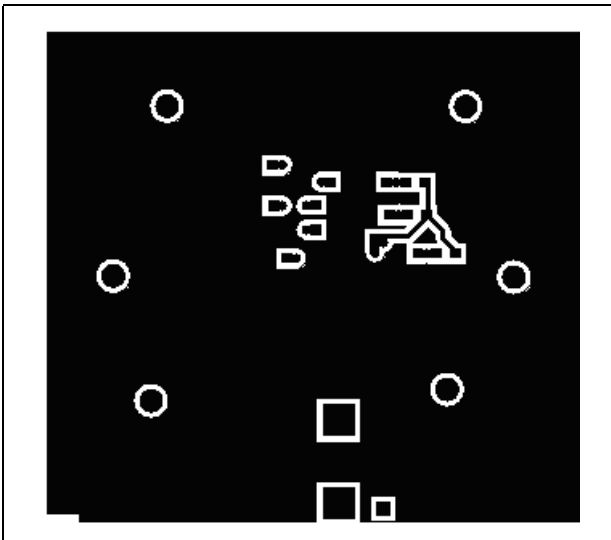
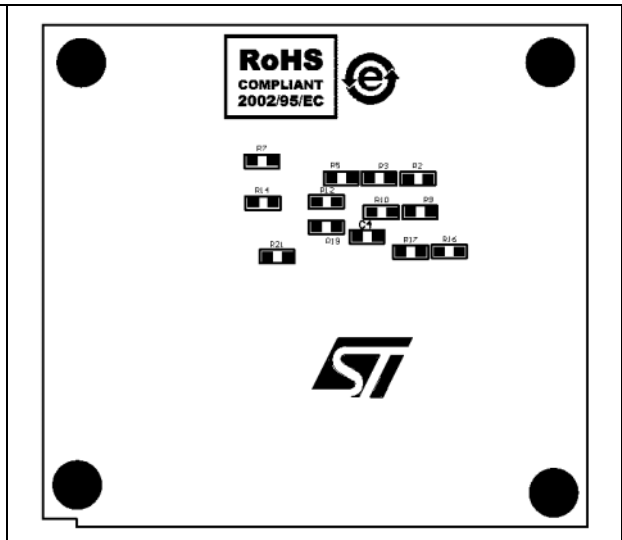

Figure 12. Bottom layout



5 Revision history

Table 3. Document revision history

Date	Revision	Changes
31-Jan-2008	1	Initial release.

Please Read Carefully:

Information in this document is provided solely in connection with ST products. STMicroelectronics NV and its subsidiaries ("ST") reserve the right to make changes, corrections, modifications or improvements, to this document, and the products and services described herein at any time, without notice.

All ST products are sold pursuant to ST's terms and conditions of sale.

Purchasers are solely responsible for the choice, selection and use of the ST products and services described herein, and ST assumes no liability whatsoever relating to the choice, selection or use of the ST products and services described herein.

No license, express or implied, by estoppel or otherwise, to any intellectual property rights is granted under this document. If any part of this document refers to any third party products or services it shall not be deemed a license grant by ST for the use of such third party products or services, or any intellectual property contained therein or considered as a warranty covering the use in any manner whatsoever of such third party products or services or any intellectual property contained therein.

UNLESS OTHERWISE SET FORTH IN ST'S TERMS AND CONDITIONS OF SALE ST DISCLAIMS ANY EXPRESS OR IMPLIED WARRANTY WITH RESPECT TO THE USE AND/OR SALE OF ST PRODUCTS INCLUDING WITHOUT LIMITATION IMPLIED WARRANTIES OF MERCHANTABILITY, FITNESS FOR A PARTICULAR PURPOSE (AND THEIR EQUIVALENTS UNDER THE LAWS OF ANY JURISDICTION), OR INFRINGEMENT OF ANY PATENT, COPYRIGHT OR OTHER INTELLECTUAL PROPERTY RIGHT.

UNLESS EXPRESSLY APPROVED IN WRITING BY AN AUTHORIZED ST REPRESENTATIVE, ST PRODUCTS ARE NOT RECOMMENDED, AUTHORIZED OR WARRANTED FOR USE IN MILITARY, AIR CRAFT, SPACE, LIFE SAVING, OR LIFE SUSTAINING APPLICATIONS, NOR IN PRODUCTS OR SYSTEMS WHERE FAILURE OR MALFUNCTION MAY RESULT IN PERSONAL INJURY, DEATH, OR SEVERE PROPERTY OR ENVIRONMENTAL DAMAGE. ST PRODUCTS WHICH ARE NOT SPECIFIED AS "AUTOMOTIVE GRADE" MAY ONLY BE USED IN AUTOMOTIVE APPLICATIONS AT USER'S OWN RISK.

Resale of ST products with provisions different from the statements and/or technical features set forth in this document shall immediately void any warranty granted by ST for the ST product or service described herein and shall not create or extend in any manner whatsoever, any liability of ST.

ST and the ST logo are trademarks or registered trademarks of ST in various countries.

Information in this document supersedes and replaces all information previously supplied.

The ST logo is a registered trademark of STMicroelectronics. All other names are the property of their respective owners.

© 2008 STMicroelectronics - All rights reserved

STMicroelectronics group of companies

Australia - Belgium - Brazil - Canada - China - Czech Republic - Finland - France - Germany - Hong Kong - India - Israel - Italy - Japan - Malaysia - Malta - Morocco - Singapore - Spain - Sweden - Switzerland - United Kingdom - United States of America

www.st.com