



Introduction

This document is intended to provide application information for the click and double-click detection functions of the FC30.

When a single or double mechanical tap is detected, the FC30 provides an interrupt signal, enabling a “mouse button-like” function for intuitive man-machine interface solutions.

A power-down mode selectable through a dedicated command ensures very low current consumption in battery-operated devices.

Contents

- 1 Theory of operation 3**
 - 1.1 Device pinout for click recognition mode 3
 - 1.2 Entering single click recognition mode 4
 - 1.3 Entering double-click recognition mode 4
 - 1.4 Exiting click recognition mode 5

- 2 Power-down mode 6**
 - 2.1 Entering power-down mode 6
 - 2.2 Exiting power-down mode 6

- 3 Revision history 7**

1 Theory of operation

The click recognition function featured in the FC30 helps to create a man-machine interface with little software loading. The device can be configured to output an interrupt signal on a dedicated pin when tapped in any direction.

If the sensor is exposed to a single input stimulus, it generates an interrupt request on inertial interrupt pin PC. A more advanced feature allows the generation of an interrupt request when a double input stimulus with fixed time between the two events is recognized, enabling a mouse button-like functionality.

Note: While the device is operating in click/double-click recognition mode, the orientation detection function is not available.

1.1 Device pinout for click recognition mode

Click recognition mode is enabled through specific commands sent to the device over the I²C bus that is available through dedicated pins (*Figure 1*).

Figure 1. FC30 pinout - I²C pins for click recognition mode

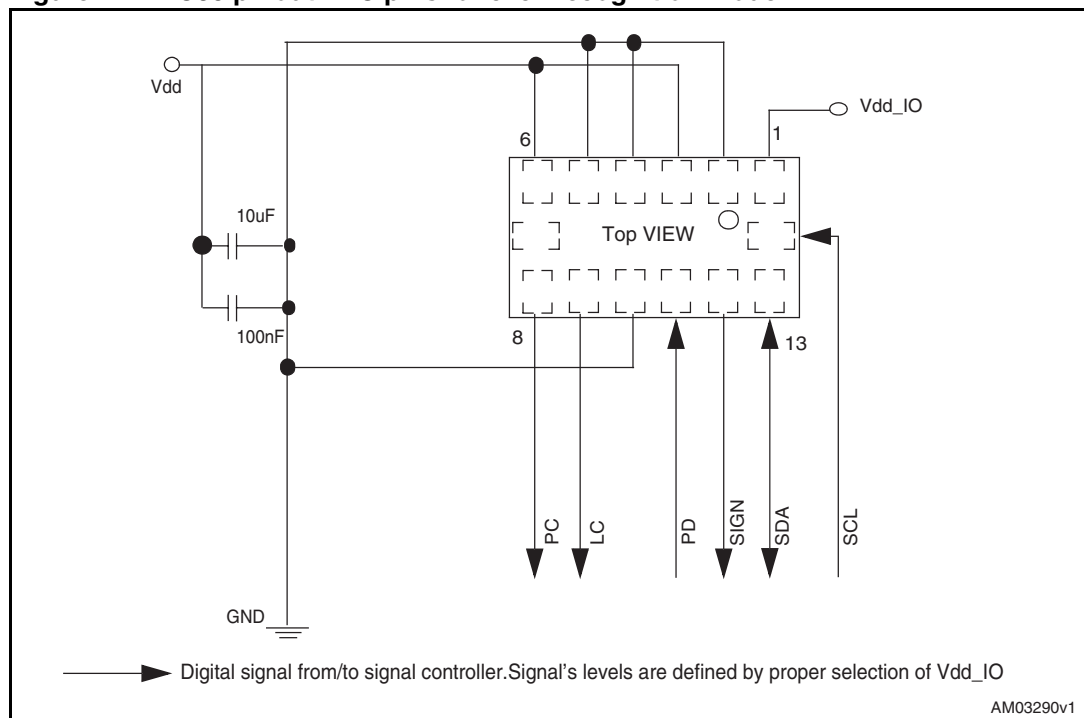

1.2 Entering single click recognition mode

To enable the single-click recognition function, the device must first be configured for power-down mode driving PD pin to GND. Then the following sequence of commands must be sent to the device through I²C bus:

```
I2C_Read(0x5D, 0x16, Value_1);
I2C_Write(0x5D, 0x16, Value_1 & 0x1F);
I2C_Write(0x1D, 0x3Bh, 0x77h);
I2C_Write(0x1D, 0x3Ch, 0x07h);
I2C_Write(0x1D, 0x3Dh, 0xFEh);
I2C_Write(0x1D, 0x3Eh, 0x10h);
I2C_Write(0x1D, 0x3Fh, 0xFFh);
I2C_Write(0x1D, 0x38h, 0x15h);
I2C_Write(0x1D, 0x20h, 0x47h);
I2C_Write(0x1D, 0x22h, 0x07h);
```

where I2C_Read and I2C_Write have the following syntax:

```
I2C_Read(SlaveAddress, SubAddress, DestinationValue);
I2C_Write(SlaveAddress, SubAddress, SourceValue);
```

At the end of the sequence the device will be in a power on state, ready to operate in single-click recognition mode and orientation detection is no longer active.

1.3 Entering double-click recognition mode

As with single-click recognition, to enable the double-click recognition function the device must be first configured for power-down mode driving PD pin to GND. Then the following sequence of commands must be sent to the device through I²C bus:

```
I2C_Read(0x5D, 0x16, Value_1);
I2C_Write(0x5D, 0x16, Value_1 & 0x1F);
I2C_Write(0x1D, 0x3Bh, 0x77h);
I2C_Write(0x1D, 0x3Ch, 0x07h);
I2C_Write(0x1D, 0x3Dh, 0xFEh);
I2C_Write(0x1D, 0x3Eh, 0x10h);
I2C_Write(0x1D, 0x3Fh, 0xFFh);
I2C_Write(0x1D, 0x38h, 0x2Ah);
I2C_Write(0x1D, 0x20h, 0x47h);
I2C_Write(0x1D, 0x22h, 0x07h);
```

At the end of the sequence, the device will be in a power on state, ready to operate in double-click recognition mode and orientation detection is no longer active.

1.4 Exiting click recognition mode

To exit from the click recognition function and restore the orientation detection, the device must be first be turned off by switching off the power supply, then turned on.

2 Power-down mode

When the FC30 is operating in click or double-click recognition mode, the PD pin must be tied to GND and no longer enabling the power-down mode. Power-down mode is still available through dedicated I²C commands.

2.1 Entering power-down mode

To enter the power-down mode, send the following I²C command to the device:

```
I2C_Write(0x1D, 0x20h, 0x00h);
```

2.2 Exiting power-down mode

To exit the power-down mode, send the following I²C command to the device:

```
I2C_Write(0x1D, 0x20h, 0x47h);
```

3 Revision history

Table 1. Document revision history

Date	Revision	Changes
17-Feb-2009	1	Initial release.

Please Read Carefully:

Information in this document is provided solely in connection with ST products. STMicroelectronics NV and its subsidiaries ("ST") reserve the right to make changes, corrections, modifications or improvements, to this document, and the products and services described herein at any time, without notice.

All ST products are sold pursuant to ST's terms and conditions of sale.

Purchasers are solely responsible for the choice, selection and use of the ST products and services described herein, and ST assumes no liability whatsoever relating to the choice, selection or use of the ST products and services described herein.

No license, express or implied, by estoppel or otherwise, to any intellectual property rights is granted under this document. If any part of this document refers to any third party products or services it shall not be deemed a license grant by ST for the use of such third party products or services, or any intellectual property contained therein or considered as a warranty covering the use in any manner whatsoever of such third party products or services or any intellectual property contained therein.

UNLESS OTHERWISE SET FORTH IN ST'S TERMS AND CONDITIONS OF SALE ST DISCLAIMS ANY EXPRESS OR IMPLIED WARRANTY WITH RESPECT TO THE USE AND/OR SALE OF ST PRODUCTS INCLUDING WITHOUT LIMITATION IMPLIED WARRANTIES OF MERCHANTABILITY, FITNESS FOR A PARTICULAR PURPOSE (AND THEIR EQUIVALENTS UNDER THE LAWS OF ANY JURISDICTION), OR INFRINGEMENT OF ANY PATENT, COPYRIGHT OR OTHER INTELLECTUAL PROPERTY RIGHT.

UNLESS EXPRESSLY APPROVED IN WRITING BY AN AUTHORIZED ST REPRESENTATIVE, ST PRODUCTS ARE NOT RECOMMENDED, AUTHORIZED OR WARRANTED FOR USE IN MILITARY, AIR CRAFT, SPACE, LIFE SAVING, OR LIFE SUSTAINING APPLICATIONS, NOR IN PRODUCTS OR SYSTEMS WHERE FAILURE OR MALFUNCTION MAY RESULT IN PERSONAL INJURY, DEATH, OR SEVERE PROPERTY OR ENVIRONMENTAL DAMAGE. ST PRODUCTS WHICH ARE NOT SPECIFIED AS "AUTOMOTIVE GRADE" MAY ONLY BE USED IN AUTOMOTIVE APPLICATIONS AT USER'S OWN RISK.

Resale of ST products with provisions different from the statements and/or technical features set forth in this document shall immediately void any warranty granted by ST for the ST product or service described herein and shall not create or extend in any manner whatsoever, any liability of ST.

ST and the ST logo are trademarks or registered trademarks of ST in various countries.

Information in this document supersedes and replaces all information previously supplied.

The ST logo is a registered trademark of STMicroelectronics. All other names are the property of their respective owners.

© 2009 STMicroelectronics - All rights reserved

STMicroelectronics group of companies

Australia - Belgium - Brazil - Canada - China - Czech Republic - Finland - France - Germany - Hong Kong - India - Israel - Italy - Japan - Malaysia - Malta - Morocco - Singapore - Spain - Sweden - Switzerland - United Kingdom - United States of America

www.st.com