

## DisplayPort, HDMI, and component input receiver

Data Brief

### Features

- DisplayPort™ 1.1 compliant receiver
- DisplayPort link comprising four main lanes and one auxiliary channel
- HDMI 1.3 compliant receiver backward compatible with DVI
- HDCP 1.3 support
- 205 MHz triple 10-bit ADC supporting PC graphics up to WUXGA resolution and component video inputs up to 1080p
- AV signal switching between DisplayPort, HDMI, and analog video inputs
- 30-bit LVTTTL output with single data rate or dual data rate per clock supports up to WUXGA resolution
- Two analog audio stereo inputs
- I2S (up to 8 channel) or SPDIF audio output ports compliant with IEC60958 and IEC61937 formats
- Audio ADC sample rate 48 kHz@16 bits

- Instant Auto™ for automatic image alignment for analog PC inputs
- Color space conversion from RGB to YUV and YUV to RGB
- SPI interface with external Serial Flash for storing firmware, user settings, and keys
- General purpose inputs/outputs (Total of 22) and LBADC input
- I2C host interface
- Energy Spectrum Management® (ESM®)
- Package: 160-pin PQFP

### Applications

- Digital reception and transmission of secure, high-bandwidth, uncompressed audio-visual streams in TV and PC applications
- Applicable as port expander in TV and Monitor designs

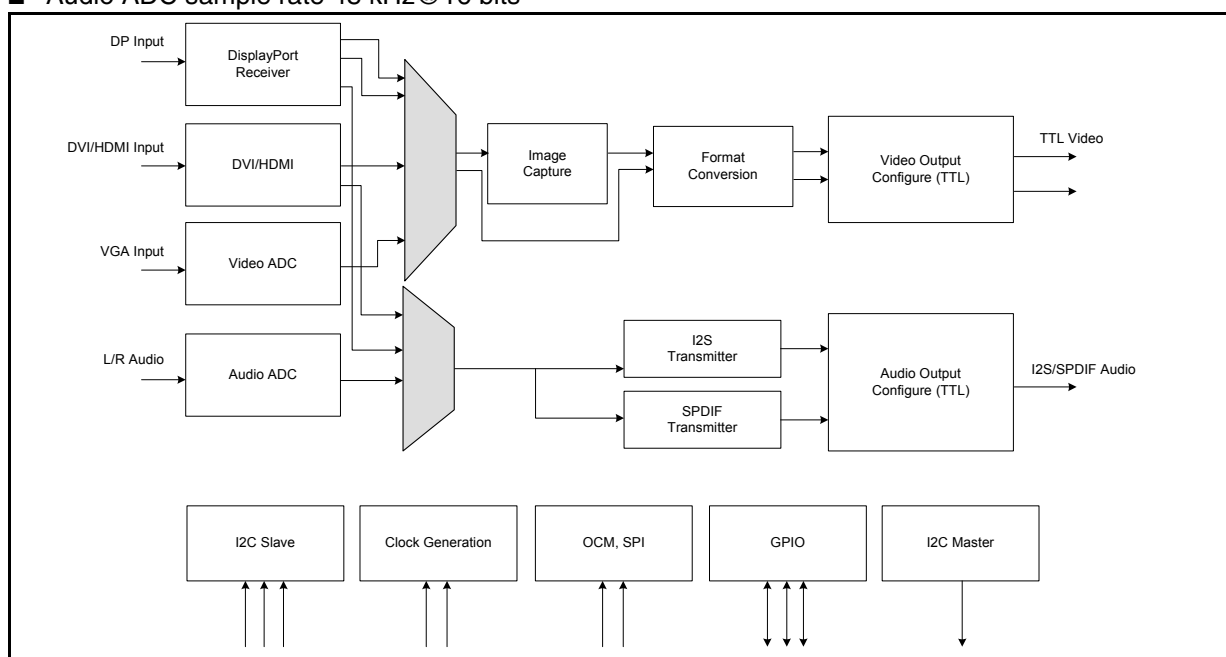

# 1 Description

The GM69010H is a highly integrated, receiver IC that converts DisplayPort (DP), HDMI, and component video input signals into TTL format targeted for TV, Monitor, and projector applications. It has an HDMI receiver, a high speed triple ADC, and a DisplayPort receiver. The DisplayPort receiver decodes and separates the audio-video signal from the encrypted digital stream. The DP link comprises four main lanes and one auxiliary channel with total available link bandwidth of 10.8 Gbps. The DP link bandwidth can be freely traded between video resolution, refresh rate, and pixel bit depth. The auxiliary channel is a 1 MBPS bidirectional, half-duplex, dedicated for link management and host-specific information exchange, such as EDID, MCCS, and CP.

The HDMI receiver is version 1.3 compliant and supports all HD formats with HDCP 1.3 authentication. The analog interface includes triple 10-bit ADC, PLL, clamp control, programmable offset gain control, and Instant Auto block optimized for capturing PC graphics signals. This device also includes analog audio inputs for direct connection with conventional analog AV sources.

The GM69010H can handle full HD video @60 Hz or PC graphics up to WUXGA resolution @60 Hz with 10/8-bit pixel depth. The decoded video data is converted to LVTTTL form and sent out on a 30-bit TTL bus with data configured as one pixel per clock or two pixels per clock (dual data rate). The extracted audio data is transmitted on multi-channel I2S or single wire SPDIF bus depending on audio type. The video color format conversion (RGB to YUV and YUV to RGB) and sample structure conversion (4:4:4 to 4:2:2 and 4:2:2 to 4:4:4) offers flexible interfacing with external video processing devices.

**Figure 1. System diagram**

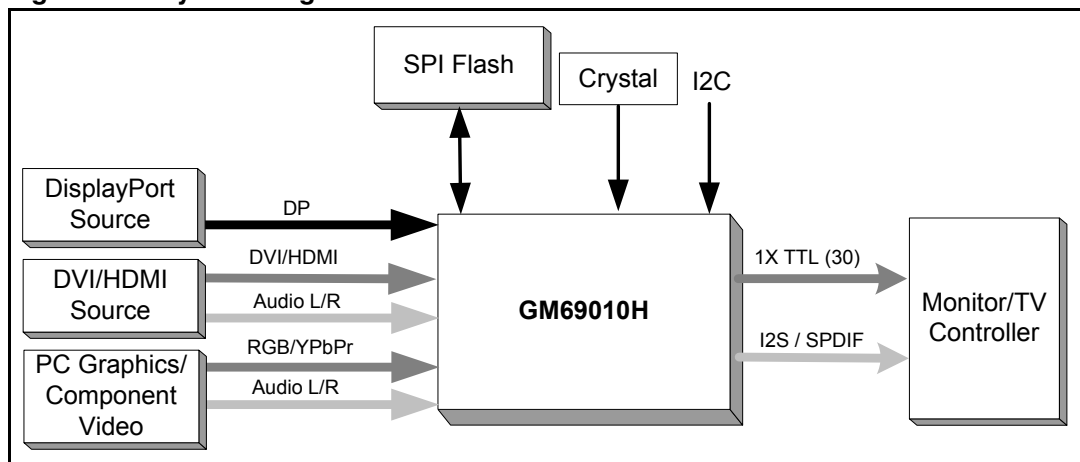

## 2 Benefits

- Highly integrated with support for leading PC and CE interconnect standards
- Proven interoperability with all major DisplayPort vendors
- HDMI 1.3 input
- HDCP 1.3 support
- On-chip microprocessor enables stand-alone operation for customized applications
- Flexible interface to ease system design – DP 1, 2, 4 lane configuration, 60/48/30/24 TTL port, YUV/RGB color format
- Low EMI
- Low power

### 3 Feature attributes

- DisplayPort 1.1 compliant receiver offering 10.8 Gbps bandwidth over 4 lanes
- HDMI 1.3 compliant receiver backward compatible with DVI
- 10-bit video ADC for component video or PC graphics analog signal capture - supports up to 1080p video or WUXGA resolution (205 MHz sample rate at 8 bits, 162 MHz sample rate at 10 bits)
- Instant Auto provides automatic image alignment for analog input from PC
- AV switch for selecting DisplayPort, HDMI, and analog video input signal
- Two pairs of analog stereo audio inputs
- Audio ADC sample rate 48 kHz @16 bits
- Color space conversion from RGB to YUV or from YUV to RGB
- SPI interface with external Serial Flash for storing firmware, system configuration data
- Secured HDCP key storage using proprietary scheme
- General purpose inputs/outputs and LBADC input
- Two-wire host interface for device configuration using external controller
- Energy Spectrum Management
- 3.3V IO, 1.8V Core
- 160-pin PQFP

## 4 Ordering information

Table 1. Order codes

| Part number | Description  |
|-------------|--------------|
| GM69010H    | 160-pin PQFP |

## 5 Revision history

**Table 2. Document revision history**

| Date        | Revision | Changes          |
|-------------|----------|------------------|
| 28-Oct-2008 | 1        | Initial release. |

**Please Read Carefully:**

Information in this document is provided solely in connection with ST products. STMicroelectronics NV and its subsidiaries ("ST") reserve the right to make changes, corrections, modifications or improvements, to this document, and the products and services described herein at any time, without notice.

All ST products are sold pursuant to ST's terms and conditions of sale.

Purchasers are solely responsible for the choice, selection and use of the ST products and services described herein, and ST assumes no liability whatsoever relating to the choice, selection or use of the ST products and services described herein.

No license, express or implied, by estoppel or otherwise, to any intellectual property rights is granted under this document. If any part of this document refers to any third party products or services it shall not be deemed a license grant by ST for the use of such third party products or services, or any intellectual property contained therein or considered as a warranty covering the use in any manner whatsoever of such third party products or services or any intellectual property contained therein.

**UNLESS OTHERWISE SET FORTH IN ST'S TERMS AND CONDITIONS OF SALE ST DISCLAIMS ANY EXPRESS OR IMPLIED WARRANTY WITH RESPECT TO THE USE AND/OR SALE OF ST PRODUCTS INCLUDING WITHOUT LIMITATION IMPLIED WARRANTIES OF MERCHANTABILITY, FITNESS FOR A PARTICULAR PURPOSE (AND THEIR EQUIVALENTS UNDER THE LAWS OF ANY JURISDICTION), OR INFRINGEMENT OF ANY PATENT, COPYRIGHT OR OTHER INTELLECTUAL PROPERTY RIGHT.**

**UNLESS EXPRESSLY APPROVED IN WRITING BY AN AUTHORIZED ST REPRESENTATIVE, ST PRODUCTS ARE NOT RECOMMENDED, AUTHORIZED OR WARRANTED FOR USE IN MILITARY, AIR CRAFT, SPACE, LIFE SAVING, OR LIFE SUSTAINING APPLICATIONS, NOR IN PRODUCTS OR SYSTEMS WHERE FAILURE OR MALFUNCTION MAY RESULT IN PERSONAL INJURY, DEATH, OR SEVERE PROPERTY OR ENVIRONMENTAL DAMAGE. ST PRODUCTS WHICH ARE NOT SPECIFIED AS "AUTOMOTIVE GRADE" MAY ONLY BE USED IN AUTOMOTIVE APPLICATIONS AT USER'S OWN RISK.**

Resale of ST products with provisions different from the statements and/or technical features set forth in this document shall immediately void any warranty granted by ST for the ST product or service described herein and shall not create or extend in any manner whatsoever, any liability of ST.

ST and the ST logo are trademarks or registered trademarks of ST in various countries.

Information in this document supersedes and replaces all information previously supplied.

The ST logo is a registered trademark of STMicroelectronics. All other names are the property of their respective owners.

© 2008 STMicroelectronics - All rights reserved

STMicroelectronics group of companies

Australia - Belgium - Brazil - Canada - China - Czech Republic - Finland - France - Germany - Hong Kong - India - Israel - Italy - Japan - Malaysia - Malta - Morocco - Singapore - Spain - Sweden - Switzerland - United Kingdom - United States of America

[www.st.com](http://www.st.com)

