

L9942 stepper motor driver

For bipolar stepper motors in automotive applications,
designed for headlight leveling and bend lighting



December 2008

www.st.com/automotive



www.BDTIC.com/ST

L9942 stepper motor driver

STMicroelectronics' L9942 is the successor of the highly established stepper motor driver, the L9935. Key applications for the L9942 include automotive headlight leveling, bend lighting and adaptive front lighting, but also HVAC flap driving and throttle positioning applications.

The device offers an extensive portfolio of features, driving bipolar stepper motors with high-efficiency and smooth operation. Micro-stepping is the preferred mode to provide low-noise operation, eliminating the effects of mechanical resonance which can lower the motor torque.

The L9942's motor stall detection capability allows position alignment without an external sensor, while its step clock is addressable via an SPI as well as by a separate input, to prevent SPI overloading when running multiple motors simultaneously. The device is housed inside a small power package with superior thermal performance – ideal for compact and lightweight systems.

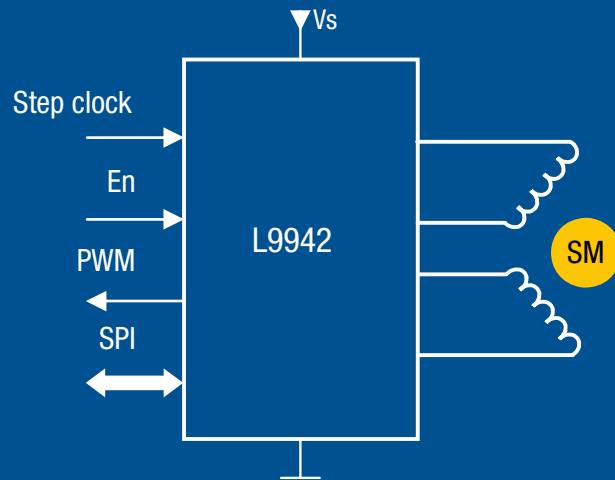
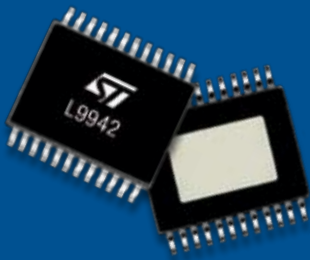

L9942 key features

- Full-, half-, mini- and micro-step operation in current mode
- SPI interface for parameter setting and step clock
- Separate step-clock input to reduce microcontroller load, allowing several devices to be driven
- Programmable stall detection
- Phase PWM output to apply stall detection via microcontroller software
- Programmable operation mode for current decay (slow, fast, auto)
- Programmable current wave forms with 9 entries (3 + 5-bit resolution) to minimize motor resonances
- Short-circuit, overvoltage and over-temperature protection
- Adjustable slew rate for Ptot minimization and EMI optimization
- Very few external components
- Small PowerSSO-24 package with exposed slug

L9942 application diagram

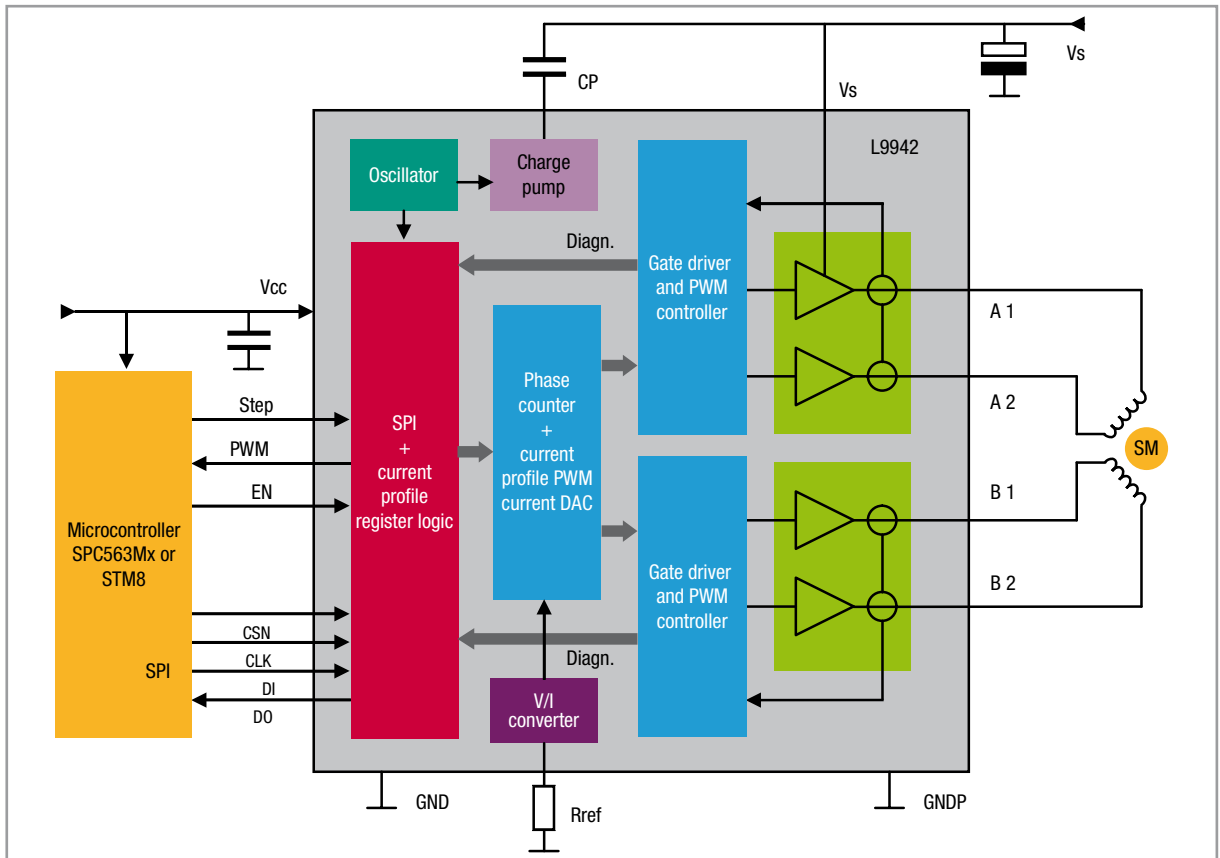

Features

$R_{DS(on)}$	Typ. 500 m Ω @ 25 °C	Operating logic supply voltage	3 to 5.3 V
Operating junction temperature	-40 to 150 °C	Max. output current	1.5 A each bridge
Max. supply voltage (pulsed)	40 V	Standby current consumption	Typ. 4 μ A @ $T_j < 25$ °C
Operating supply voltage	7 to 19 V	Package	PowerSS0-24

Failure detection

Out	Failure indication		
A1	Open	Short to V_s (typ. 2A)	Short to GND (typ. 2 A)
A2			
B1			
B2			

Device level

Thermal warning ~ 140 °C
Thermal shut down ~ 160 °C
V_s overvoltage shut down or warning (SPI configurable), typ 21 V
V_s undervoltage max. 4.8 to 6.9 V (hysteresis)
R_{ref} observation

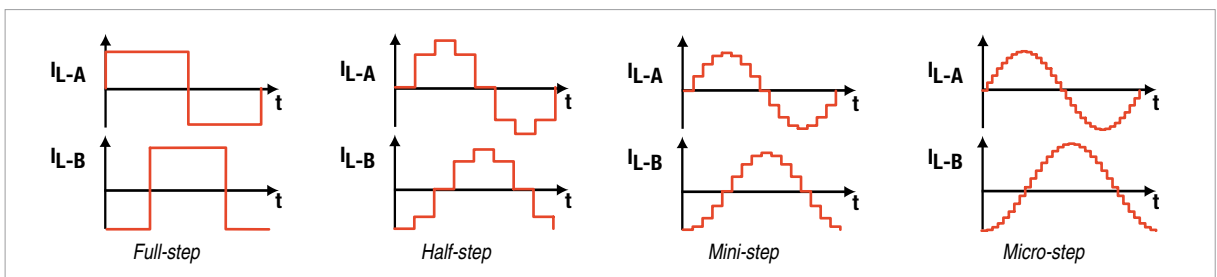

L9942 stepper motor drive waveforms

Smart headlight control

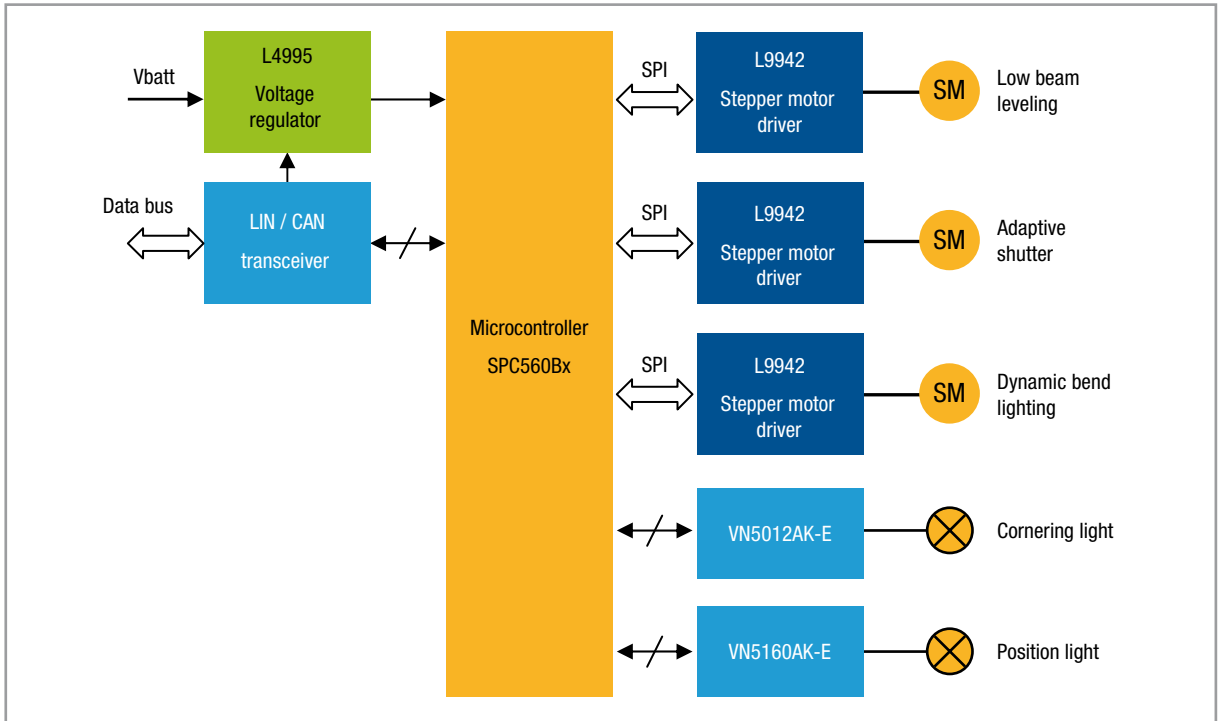

Engine management system - idle speed control

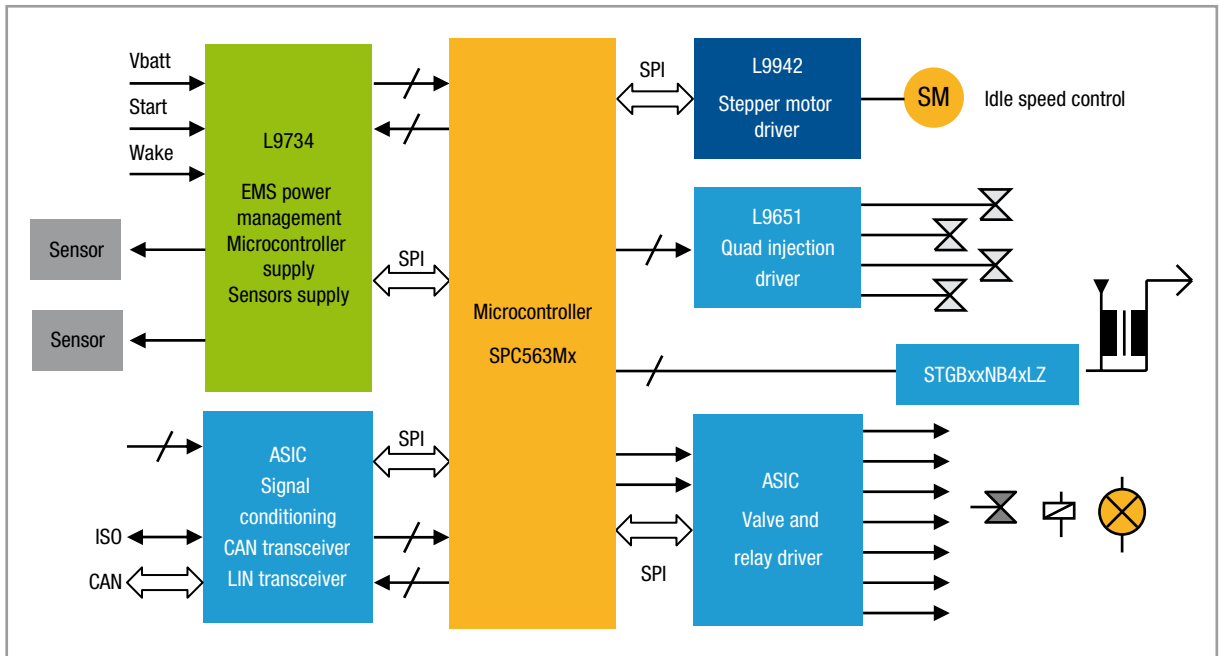

© STMicroelectronics - December 2008 - Printed in Italy - All rights reserved
 The STMicroelectronics corporate logo is a registered trademark of the STMicroelectronics group of companies.
 All other names are the property of their respective owners.

For more information on ST products and solutions,
 visit www.st.com

www.BDTIC.com/ST