

## Advanced HDMI to DisplayPort (dual mode) converter

**Data brief**

### Features

- DisplayPort® (dual mode) transmitter
  - DP 1.2 compliant
  - Link rate HBR2/HBR/RBR
  - 1, 2, or 4 lanes
  - AUX CH 1 Mbps
  - HDMI/DVI operation with level translator
- HDMI 1.4 receiver
  - Link rate up to 2.97 Gbps/data pair
  - Color depth up to 48 bits
  - 3D video timings
  - CEC
- SPDIF audio output
- HDCP repeater with embedded keys
- I2C to AUX bridge for EDID/MCCS pass through
- Device configuration options
  - SPI Flash
  - I2C host interface
- Spread spectrum on DisplayPort interface for EMI reduction
- Deep color support
  - RGB/YCC (4:4:4) – 16-bit color
  - YCC (4:2:2/4:2:0) – 16-bit color
  - Color space conversion – YUV to RGB and RGB to YUV
- Bandwidth
  - Video resolution up to 4K x 2K @ 30 Hz; 1920 x 1080 @ 120 Hz
  - Audio 7.1 Ch up to 192 kHz sample rate
- Low power operation; active 500 mW, standby 25 mW
- Package
  - 81 BGA (8 x 8 mm)
- Power supply voltages
  - 3.3 V I/O; 1.2 V core

### Applications

- Audio-video accessory (dongle) for PC/notebooks and docking stations

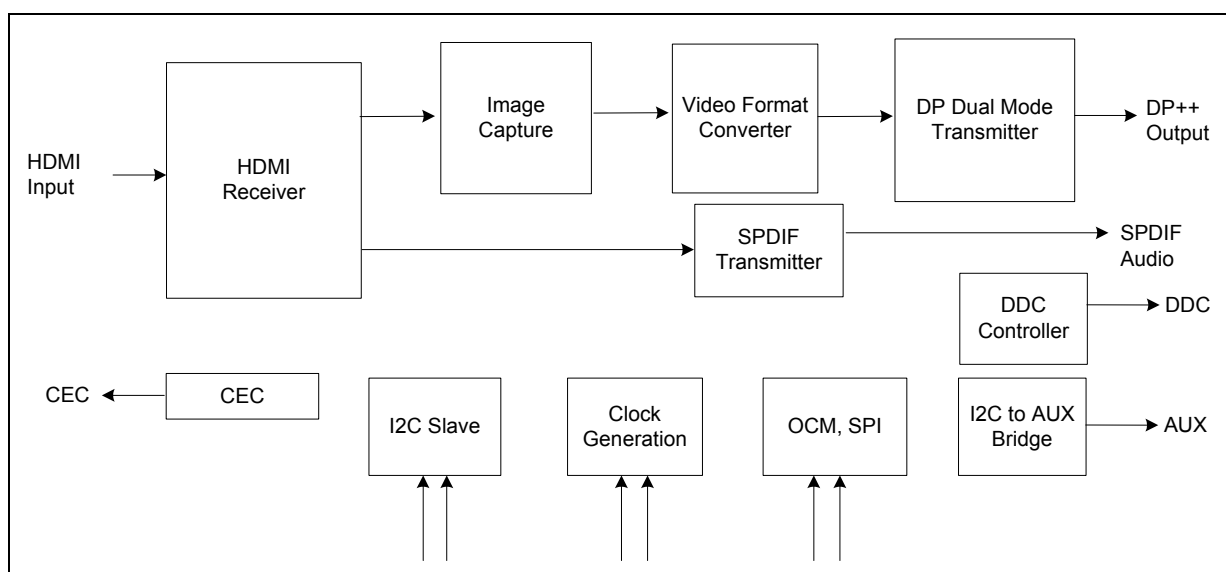

# 1 Description

The STDP2600 is a high-speed HDMI to DisplayPort converter IC targeted for applications such as audio-video accessories, docking stations, notebook motherboard designs, etc. This device includes an HDMI 1.4 compliant receiver and a VESA DP Standard Ver. 1.2 compliant dual mode transmitter, implementing a single link DisplayPort output port comprising four Main lanes, AUX CH, and HPD.

The STDP2600 uses ST's latest generation DisplayPort dual mode transmitter technology that supports both DisplayPort and TMDS signal formats (DP++). DisplayPort transmitter supports HBR2 speed, a data rate of 5.4 Gbps per lane with a total bandwidth of 21.6 Gbps link rate. The transmitter is also capable of supporting HDMI or single link DVI output through a passive level translator (dongle). The HDMI receiver unit supports link rate up to 2.97 Gbps that corresponds to a pixel rate of 297 MHz, quite adequate for handling video timings up to FHD 120 Hz 3D formats. This device delivers deep color video up to 16-bits per color at 1080p 60 Hz and lower video resolutions. STDP2600 allows audio transport from the source to desired audio rendering devices over the DP++ output or through the SPDIF port. The audio signal from the source can be routed simultaneously to DP++ and SPDIF output ports. For example, STDP2600 allows routing of any two audio channels on the SPDIF port, while transporting up to eight channels on the DP++ port.

The STDP2600 supports RGB and YCbCr colorimetric formats with color depth of 16, 12, 10, and 8 bits. This device features HDCP 1.3 content protection scheme with an embedded key option for secure transmission of digital audio-video content. It also operates as an HDCP repeater for the downstream sink.

The I2C-to-AUX translator in STDP2600 allows the upstream HDMI source to access EDID and transfer MCCS commands to a downstream DisplayPort sink device over the DisplayPort interface. This device has an on-chip microcontroller with SPI and I2C host interface for system configuration purposes. STDP2600 can be configured with an external SPI Flash for custom applications or simply configured from an external host controller through I2C interface.

## 2 Application overview

Figure 1. STDP2600 in BD player/game console accessory application

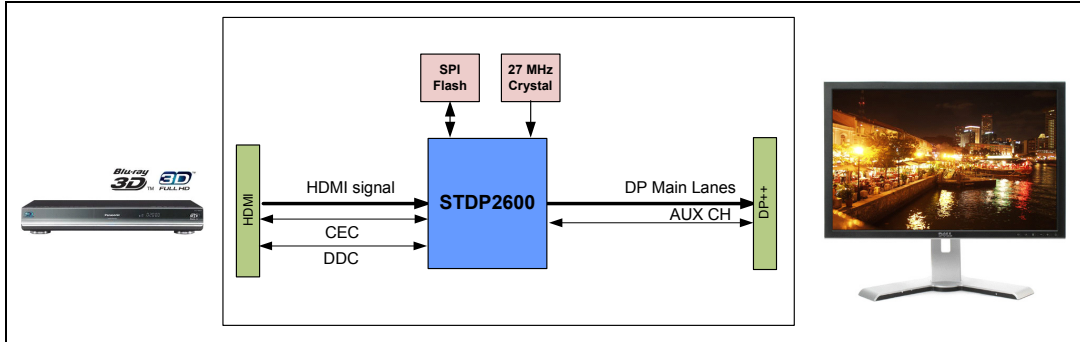

## 3 Feature attributes

### 3.1 Input interface

- HDMI standard Ver. 1.4 compliant (DC coupled)
- Link rate: 2.97 Gbps/data pair max
- Video: HDMI 1.4 primary and secondary timing formats, as well as CEA861 timing formats with pixel repetition for lower resolutions
- Deep color encoding up to 48 bits/pixel in 444 and 422; encoding in 601, 709, and IEC61966 color spaces
- Audio: IEC60958 L-PCM and IEC61937 streams up to 24 bits/sample from 32 kHz to 192 kHz
- DDC slave port
- HPD assertion

### 3.2 Output interface

- DP++ interface featuring
  - AC coupled DisplayPort Ver. 1.2 compliant transmitter
  - AC coupled HDMI 1.4 transmitter (with external level shifter)
- DP main link configuration (SST format only, no MST format support)
  - HBR2/HBR/RBR link rate
  - 1, 2, or 4 lanes
- AUX CH: Manchester transaction format
- HPD: IRQ\_HPDP assertion
- Video: EDID 1.4 and CEA861 video timing and formats from 24 to 48 bits/pixel in RGB or YCC422 or YcC444 colorimetry
- Audio: DisplayPort 1.2 standard info frame packets and IEC60958/61937 type audio stream packets ranging from 16 to 24 bits/sample, 32 to 192 kHz sample rates
- HDMI link rate: 2.97 Gbps/data pair max

### 3.3 Deep color support

- RGB/YCC (4:4:4) – 16-bit color
- YCC (4:2:2/4:2:0) – 16-bit color
- Color space conversion – YUV to RGB and RGB to YUV

### 3.4 Supported video timings

- 4096 x 2160 (4K x 2K) 24 Hz/30 Hz; 24 bits/pixel
- 1920 x 1080 (FHD) 120 Hz: 24 bits/pixel
- 2560 x 1600 (WQXGA) 60 Hz: 24 bits/pixel
- Up to 1920 x 1080 (FHD) 60 Hz, 48, 36, 30 bits/pixel
- All compatible 3D formats defined in DP 1.2 and HDMI 1.4 specifications
- All standard CEA861 timing formats

### 3.5 Supported audio timings

- All audio formats as specified in DP 1.2 and HDMI 1.4 specifications
- SPDIF; 2-Ch LPCM, AC3, DTS, bit depth up to 24 bits, sample rate up to 192 kHz

### 3.6 Control channel interfaces

- AUX CH, I2C host interface, SPI (optional), and UART (UART for test/debug purposes only)

### 3.7 HDCP 1.3 support

- Key sets for HDMI RX and DP/HDMI TX integrated in one-time programmable ROM (OTP)
- Standalone HDCP repeater capability

### 3.8 Package

- 81 BGA (8 x 8 mm), 0.8 ball pitch

### 3.9 Power supply voltages

- 3.3 V I/O; 1.2 V core

### 3.10 ESD

- 2 KV HBM, 500 V CDM

## 4 Ordering information

**Table 1. Order codes**

| Part number | Description       |
|-------------|-------------------|
| STDP2600    | 81 BGA (8 x 8 mm) |

In order to meet environmental requirements, ST offers these devices in different grades of ECOPACK® packages, depending on their level of environmental compliance. ECOPACK® specifications, grade definitions and product status are available at: [www.st.com](http://www.st.com). ECOPACK® is an ST trademark.

## 5 Revision history

Table 2. Document revision history

| Date        | Revision | Changes          |
|-------------|----------|------------------|
| 05-Jun-2012 | 1        | Initial release. |

**Please Read Carefully:**

Information in this document is provided solely in connection with ST products. STMicroelectronics NV and its subsidiaries ("ST") reserve the right to make changes, corrections, modifications or improvements, to this document, and the products and services described herein at any time, without notice.

All ST products are sold pursuant to ST's terms and conditions of sale.

Purchasers are solely responsible for the choice, selection and use of the ST products and services described herein, and ST assumes no liability whatsoever relating to the choice, selection or use of the ST products and services described herein.

No license, express or implied, by estoppel or otherwise, to any intellectual property rights is granted under this document. If any part of this document refers to any third party products or services it shall not be deemed a license grant by ST for the use of such third party products or services, or any intellectual property contained therein or considered as a warranty covering the use in any manner whatsoever of such third party products or services or any intellectual property contained therein.

**UNLESS OTHERWISE SET FORTH IN ST'S TERMS AND CONDITIONS OF SALE ST DISCLAIMS ANY EXPRESS OR IMPLIED WARRANTY WITH RESPECT TO THE USE AND/OR SALE OF ST PRODUCTS INCLUDING WITHOUT LIMITATION IMPLIED WARRANTIES OF MERCHANTABILITY, FITNESS FOR A PARTICULAR PURPOSE (AND THEIR EQUIVALENTS UNDER THE LAWS OF ANY JURISDICTION), OR INFRINGEMENT OF ANY PATENT, COPYRIGHT OR OTHER INTELLECTUAL PROPERTY RIGHT.**

**UNLESS EXPRESSLY APPROVED IN WRITING BY TWO AUTHORIZED ST REPRESENTATIVES, ST PRODUCTS ARE NOT RECOMMENDED, AUTHORIZED OR WARRANTED FOR USE IN MILITARY, AIR CRAFT, SPACE, LIFE SAVING, OR LIFE SUSTAINING APPLICATIONS, NOR IN PRODUCTS OR SYSTEMS WHERE FAILURE OR MALFUNCTION MAY RESULT IN PERSONAL INJURY, DEATH, OR SEVERE PROPERTY OR ENVIRONMENTAL DAMAGE. ST PRODUCTS WHICH ARE NOT SPECIFIED AS "AUTOMOTIVE GRADE" MAY ONLY BE USED IN AUTOMOTIVE APPLICATIONS AT USER'S OWN RISK.**

Resale of ST products with provisions different from the statements and/or technical features set forth in this document shall immediately void any warranty granted by ST for the ST product or service described herein and shall not create or extend in any manner whatsoever, any liability of ST.

ST and the ST logo are trademarks or registered trademarks of ST in various countries.

Information in this document supersedes and replaces all information previously supplied.

The ST logo is a registered trademark of STMicroelectronics. All other names are the property of their respective owners.

© 2012 STMicroelectronics - All rights reserved

STMicroelectronics group of companies

Australia - Belgium - Brazil - Canada - China - Czech Republic - Finland - France - Germany - Hong Kong - India - Israel - Italy - Japan - Malaysia - Malta - Morocco - Philippines - Singapore - Spain - Sweden - Switzerland - United Kingdom - United States of America

[www.st.com](http://www.st.com)