

1300 W PMSM compressor and fan drive plus digital PFC for room air conditioner (RAC) applications

Databrief

Features

- Nominal power 1300 W, max. power 1700 W
- Digital PFC section:
 - single-stage boost converter
 - AC mains current sensing
 - DC bus voltage sensing
 - hardware overcurrent protection
 - hardware overvoltage protection
 - AC mains voltage zero crossing detection
 - rectified AC mains voltage sensing
 - external boost inductor
- Inverter section (motor 1 drive):
 - IGBT intelligent power module STGIPS20K60 in SDIP 25L molded package
 - 3-shunt or DC link motor current sensing
 - hardware overcurrent protection
 - heatsink temperature measurement
 - overcurrent protection disabling network;
- Control section:
 - centralized dual motor control and PFC drive, using the STM32F103RCT6
 - MC connector to drive the second motor power stage (a compatible power board, such as the STEVAL-IHM021V1, STEVAL-IHM024V1, or STEVAL-IHM032V1, can be plugged here)
 - SWD programming and debugging
 - JTAG programming
 - opto-isolated USART communication
- other functions:
 - user key, reset, potentiometer, user LED, NTC relay, test points
- Power supply:
 - +15 V, +3.3 V power supply
- RoHS compliant

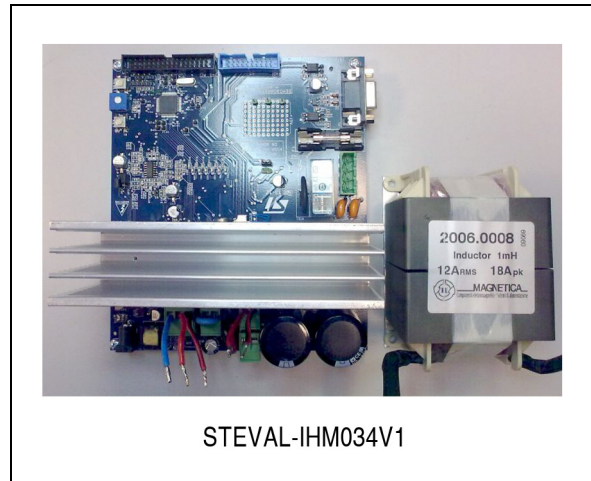

1 Description

The STEVAL-IHM034V1 is a complete motor control kit solution for the evaluation of STMicroelectronics wide product portfolio tailored to applications where it is necessary to drive, simultaneously, two motors in sensorless field oriented control (FOC) and perform active power factor correction (PFC) through digital control of a single-stage boost DC-DC converter.

Typical application is in room air conditioners (RACs), where this ST solution can drive the compressor, the outdoor fan and PFC. The microcontroller unit is the STMicroelectronics ARM™ Cortex-M3 core-based STM32F103RC, which is able to carry out all the above mentioned tasks simultaneously. The board is compatible for use with the STM32F2 series, and with the ARM™ Cortex-M4 core-based STM32F4 series.

Motor 1 is powered by the onboard SLLIMM™ (small low-loss intelligent molded module) STGIPS20K60; Motor 2 can be powered by an external STMicroelectronics power stage, such as those that can be evaluated by means of the STEVAL-IHM021V1, STEVAL-IHM024V1, STEVAL-IHM032V1, or STEVAL-IHM035V1. Simultaneously, the same microcontroller unit drives the onboard boost PFC stage, designed with the STGW35HF60W ultrafast IGBT, or alternatively for the high switching frequency STW38N65M5 MDmesh V Power MOSFET, and STTH15R06D Turbo2 ultrafast diode or STPSC1206D Schottky silicon carbide diode.

The STEVAL-IHM034V1 can be used together with STM32 permanent magnet synchronous motors (PMSM) single/dual FOC software development kit (SDK) v3.2 and its compatible PFC firmware v1.0 plug-in.

2 Schematic diagram

Figure 1. Schematic diagram (part 1)

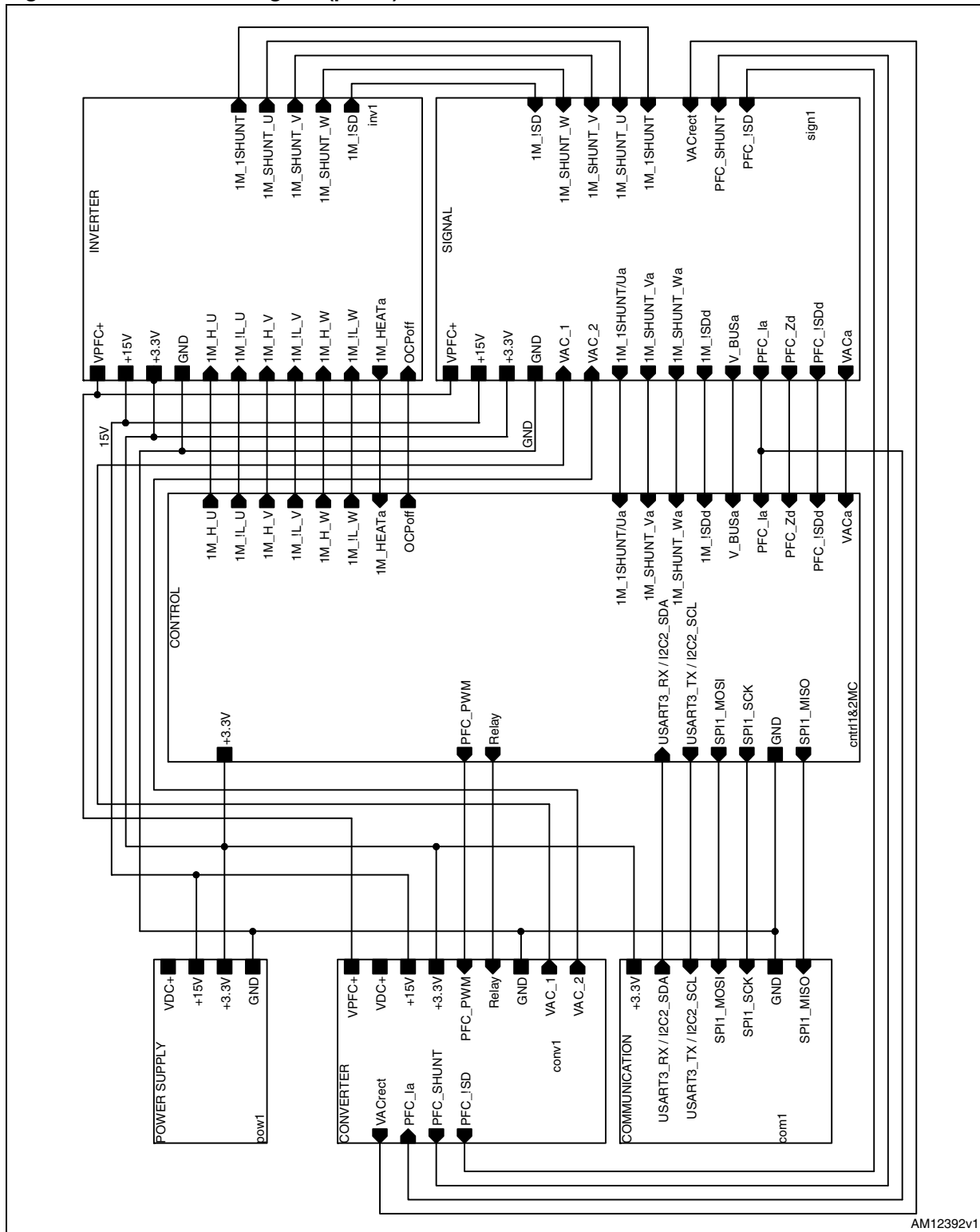
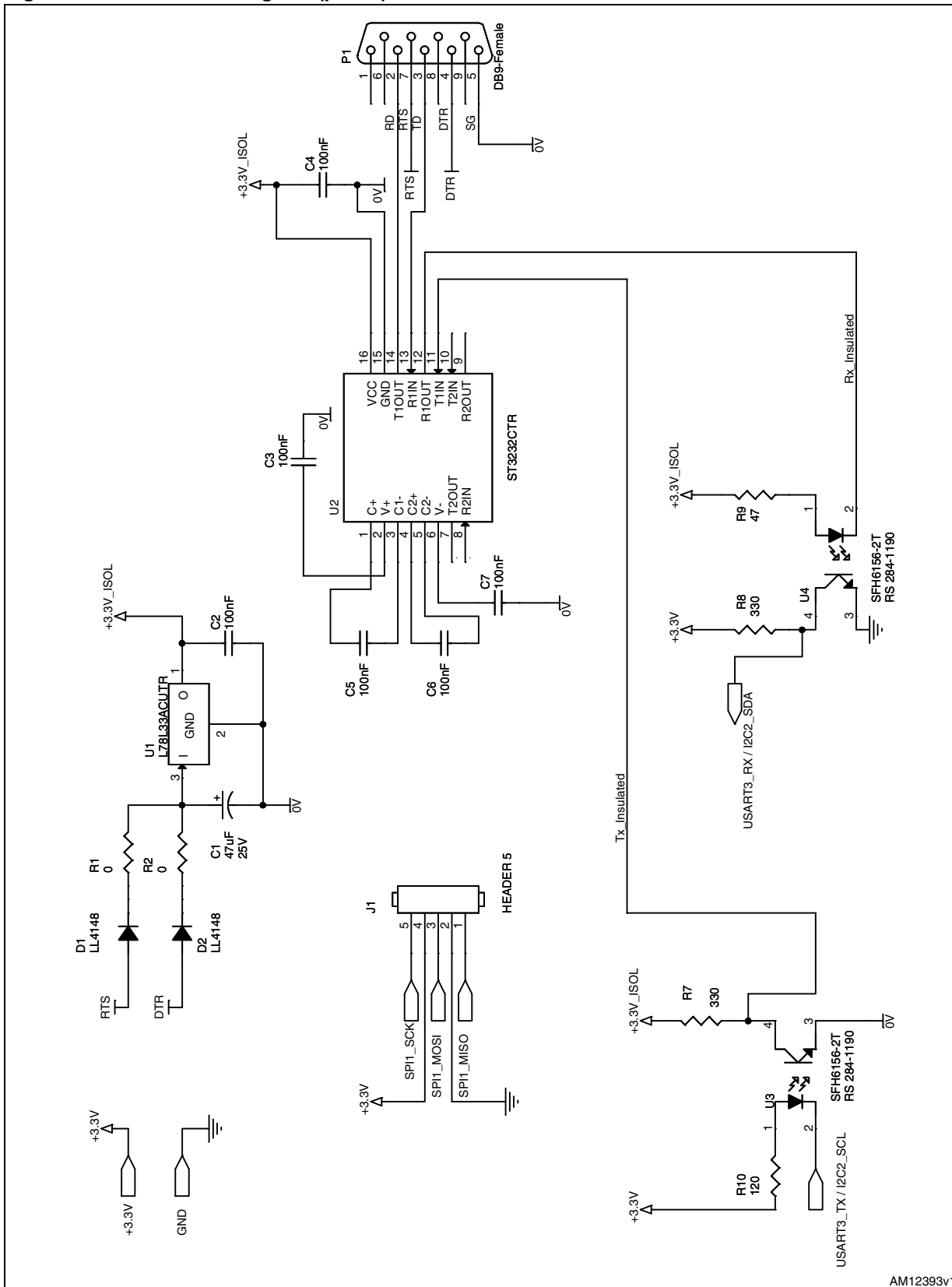

Figure 2. Schematic diagram (part 2)



AM12393v1



Figure 3. Schematic diagram (part 3)

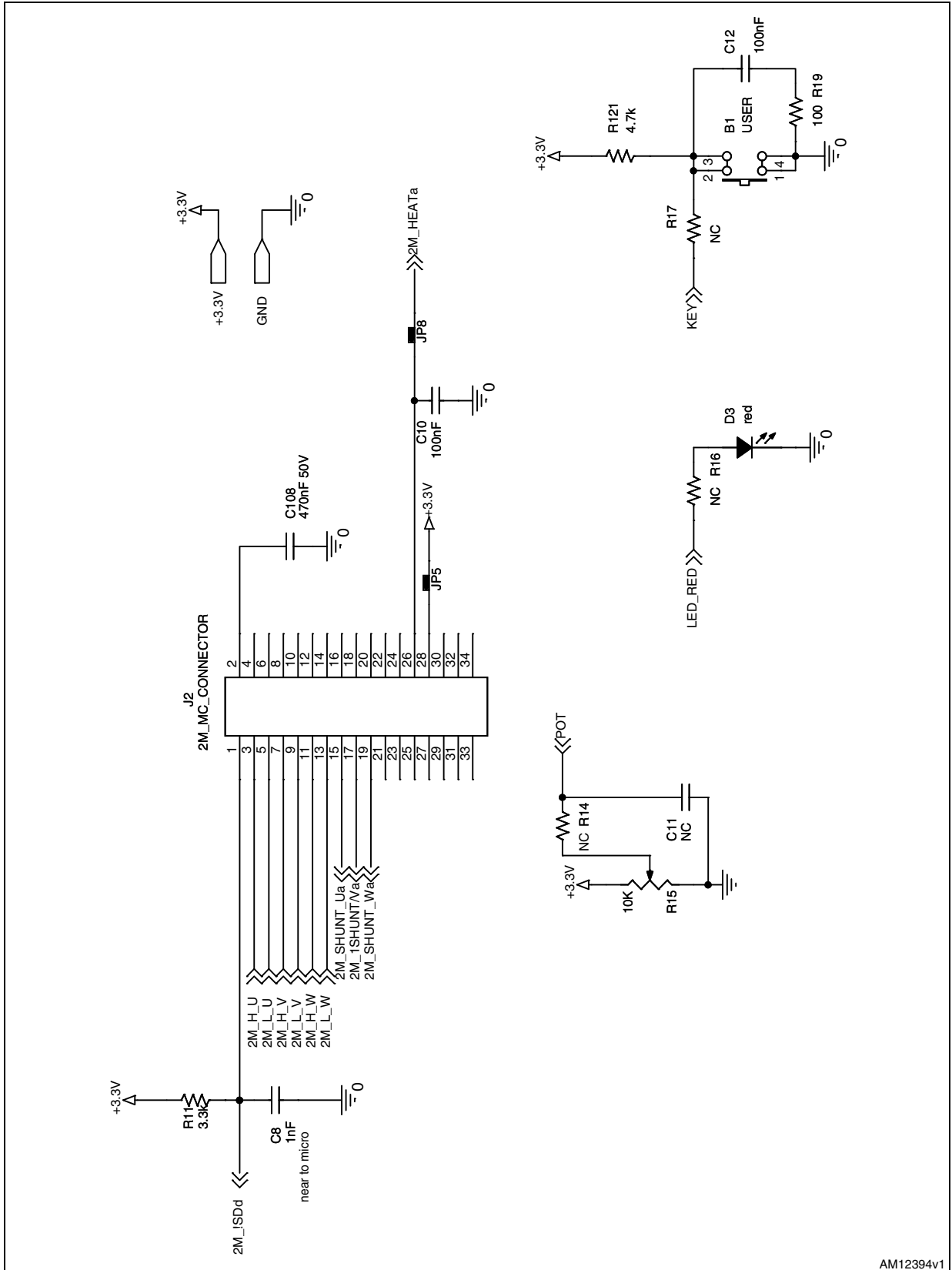

AM12394v1

Figure 4. Schematic diagram (part 4)

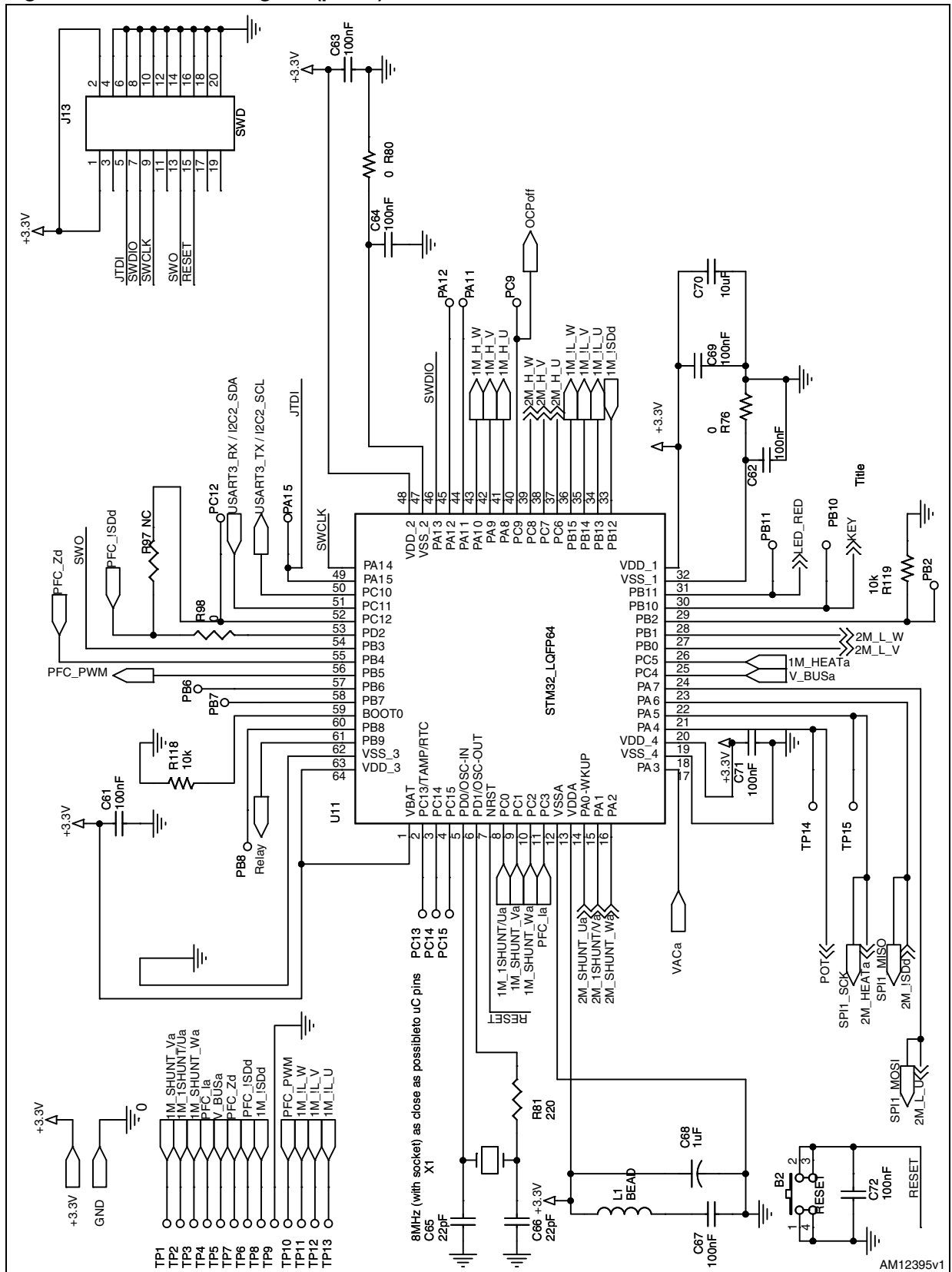
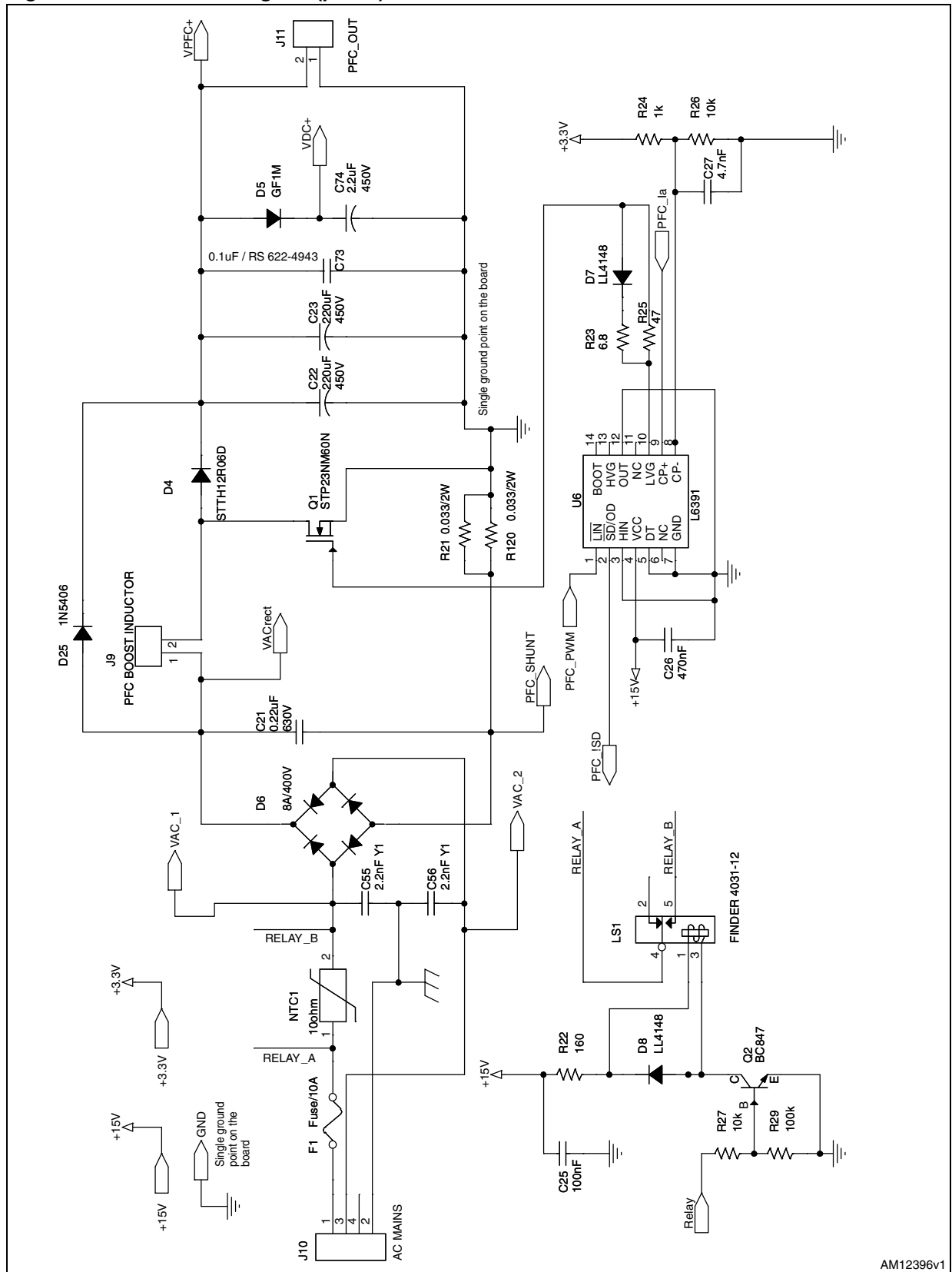

Figure 5. Schematic diagram (part 5)



AM12396v1



Figure 6. Schematic diagram (part 6)

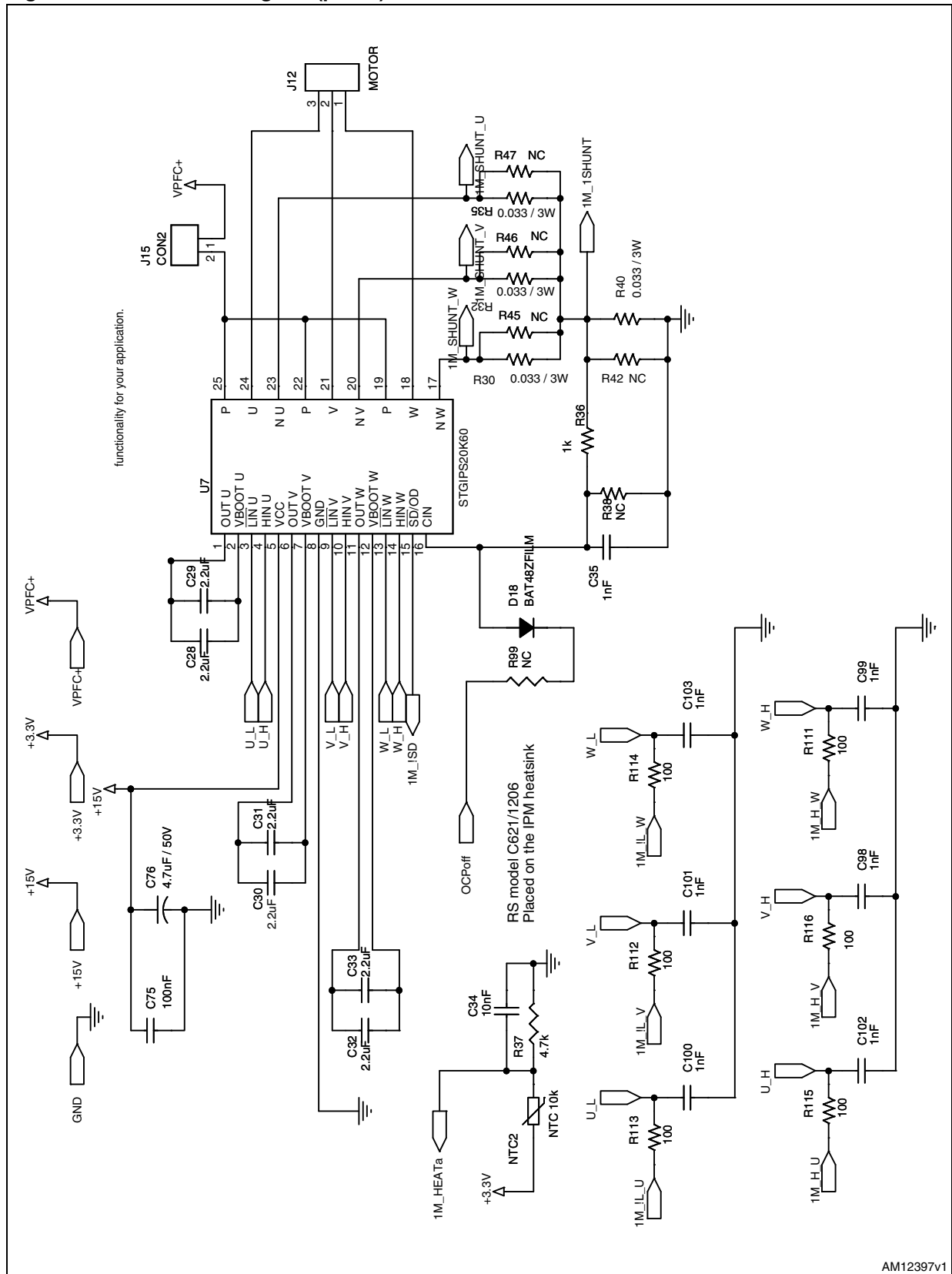
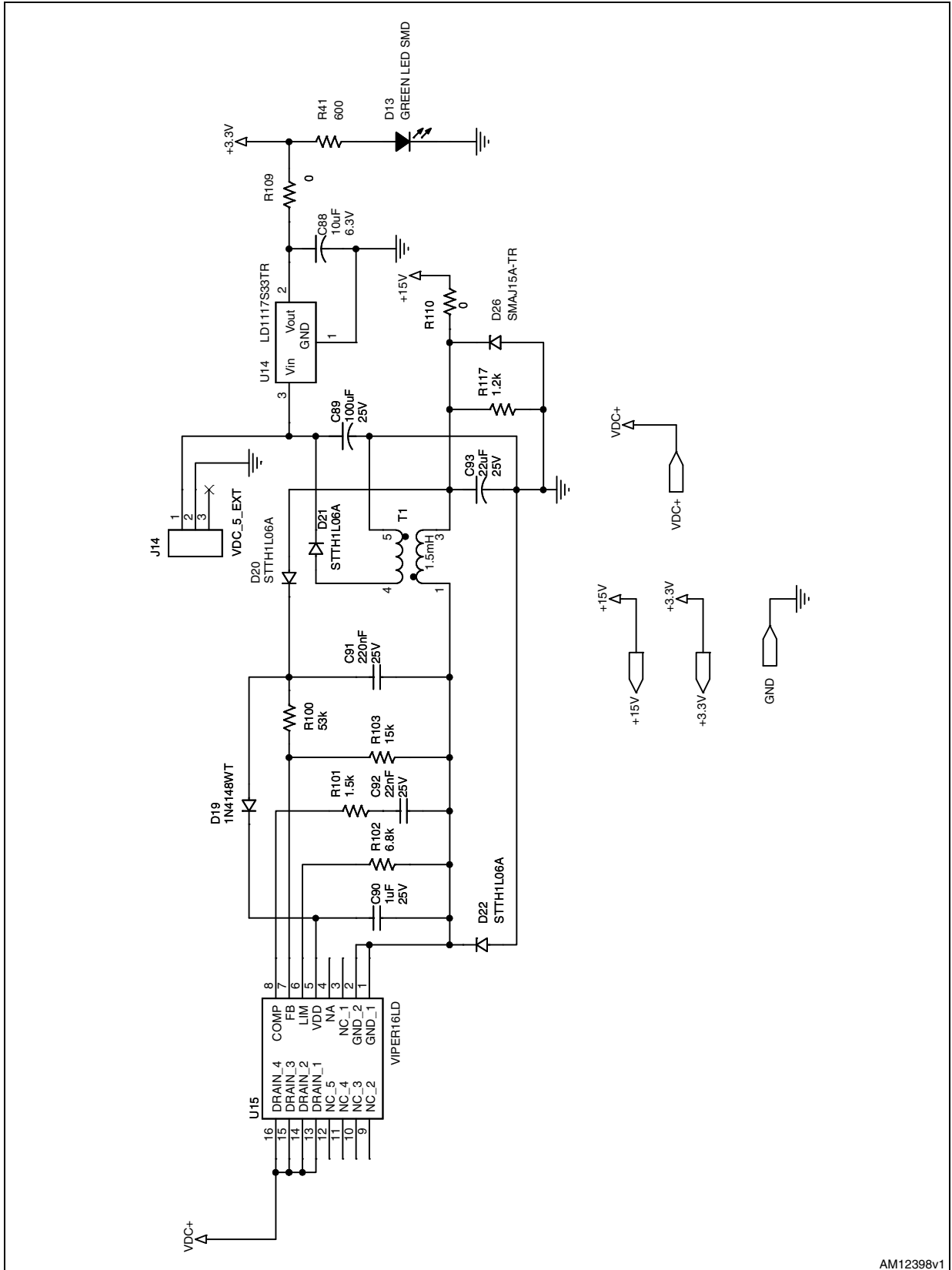
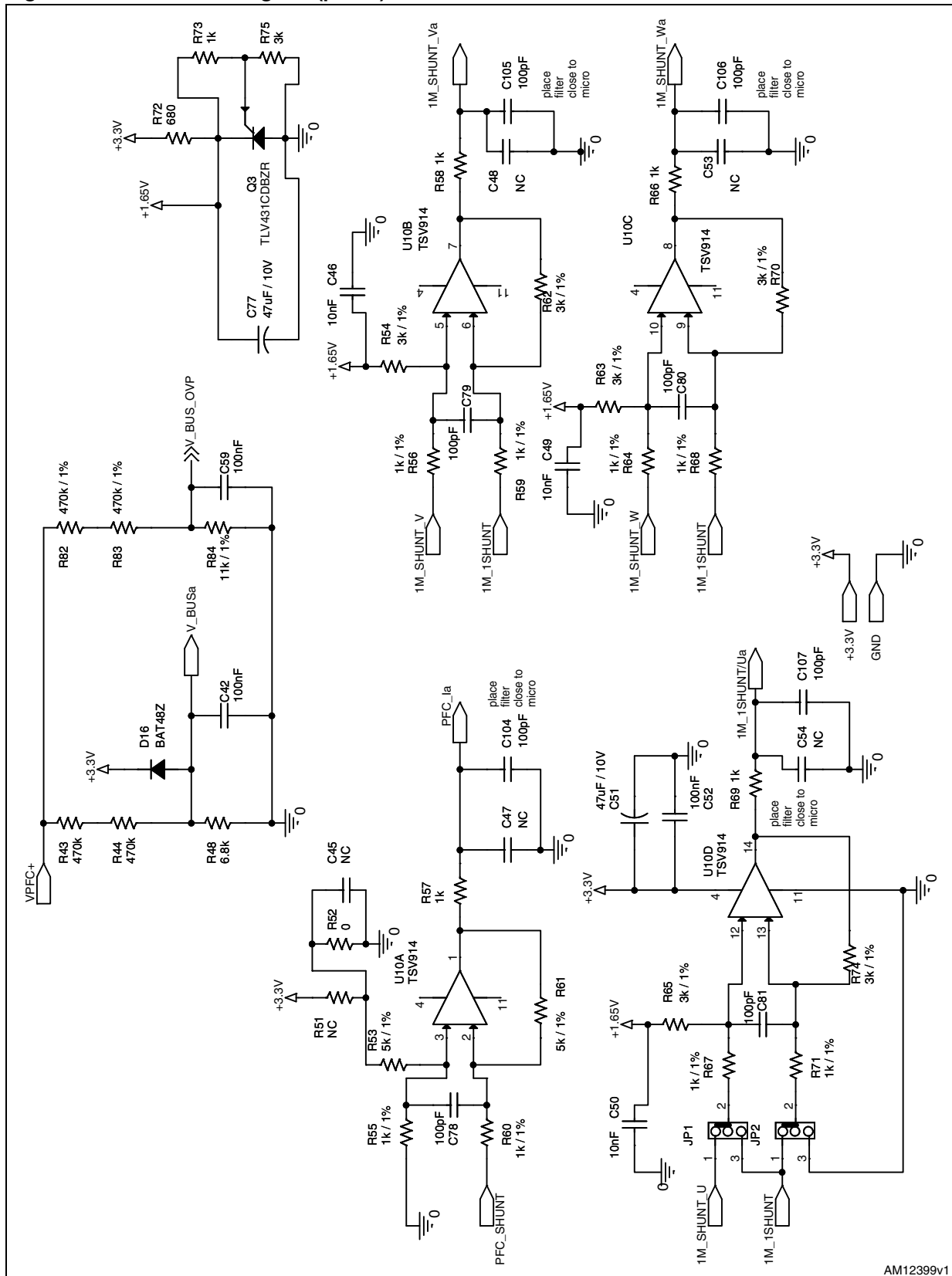

Figure 7. Schematic diagram (part 7)



AM12398v1

Figure 8. Schematic diagram (part 8)



AM12399v1



Figure 9. Schematic diagram (part 9)

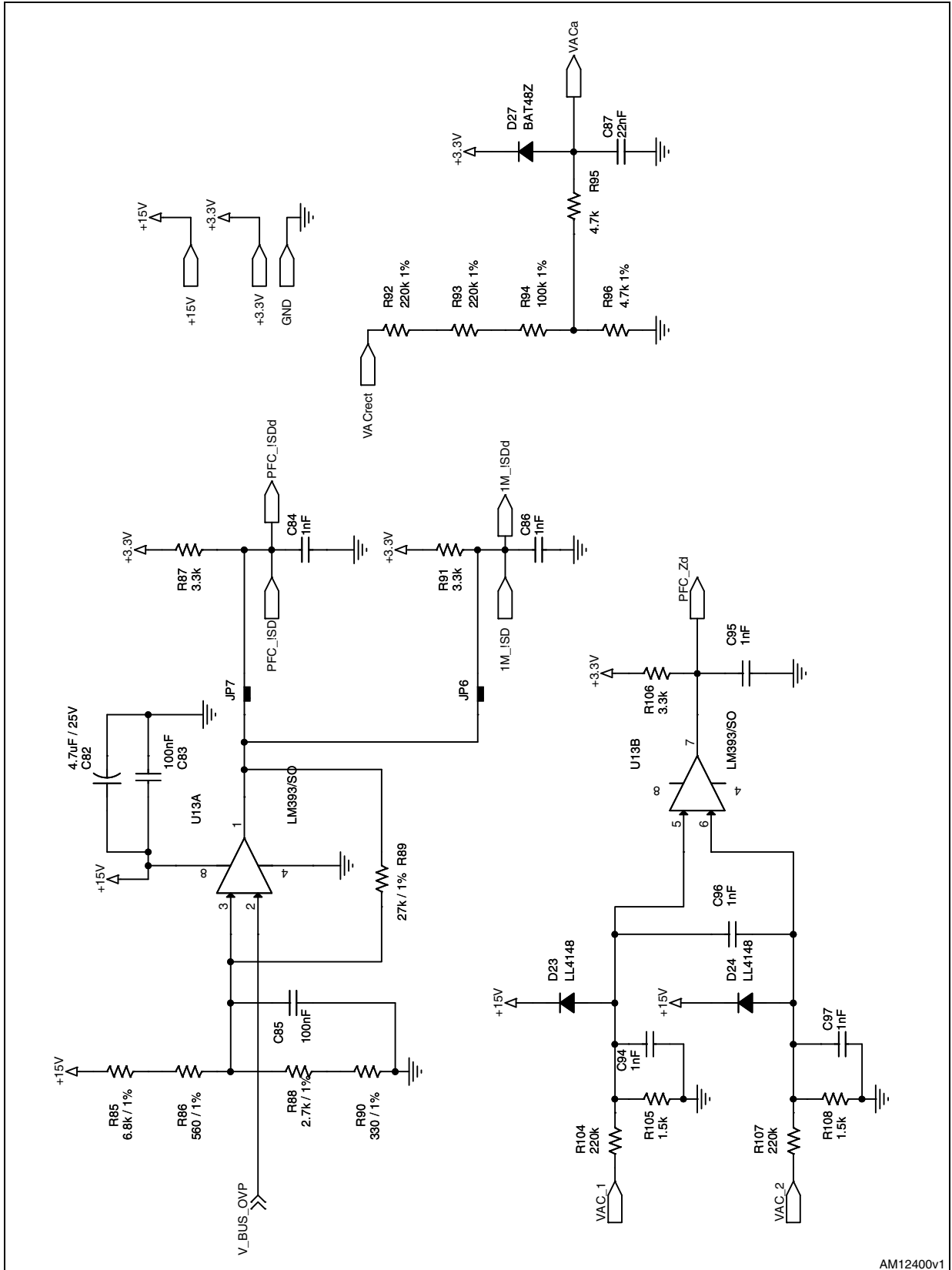

AM12400v1

3 Revision history

Table 1. Document revision history

Date	Revision	Changes
15-Jun-2012	1	Initial release.

Please Read Carefully:

Information in this document is provided solely in connection with ST products. STMicroelectronics NV and its subsidiaries ("ST") reserve the right to make changes, corrections, modifications or improvements, to this document, and the products and services described herein at any time, without notice.

All ST products are sold pursuant to ST's terms and conditions of sale.

Purchasers are solely responsible for the choice, selection and use of the ST products and services described herein, and ST assumes no liability whatsoever relating to the choice, selection or use of the ST products and services described herein.

No license, express or implied, by estoppel or otherwise, to any intellectual property rights is granted under this document. If any part of this document refers to any third party products or services it shall not be deemed a license grant by ST for the use of such third party products or services, or any intellectual property contained therein or considered as a warranty covering the use in any manner whatsoever of such third party products or services or any intellectual property contained therein.

UNLESS OTHERWISE SET FORTH IN ST'S TERMS AND CONDITIONS OF SALE ST DISCLAIMS ANY EXPRESS OR IMPLIED WARRANTY WITH RESPECT TO THE USE AND/OR SALE OF ST PRODUCTS INCLUDING WITHOUT LIMITATION IMPLIED WARRANTIES OF MERCHANTABILITY, FITNESS FOR A PARTICULAR PURPOSE (AND THEIR EQUIVALENTS UNDER THE LAWS OF ANY JURISDICTION), OR INFRINGEMENT OF ANY PATENT, COPYRIGHT OR OTHER INTELLECTUAL PROPERTY RIGHT.

UNLESS EXPRESSLY APPROVED IN WRITING BY TWO AUTHORIZED ST REPRESENTATIVES, ST PRODUCTS ARE NOT RECOMMENDED, AUTHORIZED OR WARRANTED FOR USE IN MILITARY, AIR CRAFT, SPACE, LIFE SAVING, OR LIFE SUSTAINING APPLICATIONS, NOR IN PRODUCTS OR SYSTEMS WHERE FAILURE OR MALFUNCTION MAY RESULT IN PERSONAL INJURY, DEATH, OR SEVERE PROPERTY OR ENVIRONMENTAL DAMAGE. ST PRODUCTS WHICH ARE NOT SPECIFIED AS "AUTOMOTIVE GRADE" MAY ONLY BE USED IN AUTOMOTIVE APPLICATIONS AT USER'S OWN RISK.

Resale of ST products with provisions different from the statements and/or technical features set forth in this document shall immediately void any warranty granted by ST for the ST product or service described herein and shall not create or extend in any manner whatsoever, any liability of ST.

ST and the ST logo are trademarks or registered trademarks of ST in various countries.

Information in this document supersedes and replaces all information previously supplied.

The ST logo is a registered trademark of STMicroelectronics. All other names are the property of their respective owners.

© 2012 STMicroelectronics - All rights reserved

STMicroelectronics group of companies

Australia - Belgium - Brazil - Canada - China - Czech Republic - Finland - France - Germany - Hong Kong - India - Israel - Italy - Japan - Malaysia - Malta - Morocco - Philippines - Singapore - Spain - Sweden - Switzerland - United Kingdom - United States of America

www.st.com

