

## STLED325 SECTION

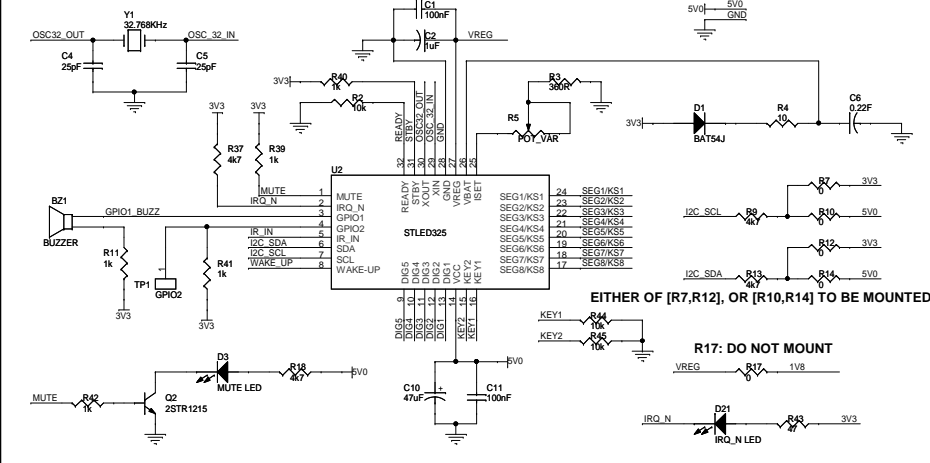

EITHER OF [R7,R12], OR [R10,R14] TO BE MOUNTED  
**R17: DO NOT MOUNT**

## MICROCONTROLLER SECTION

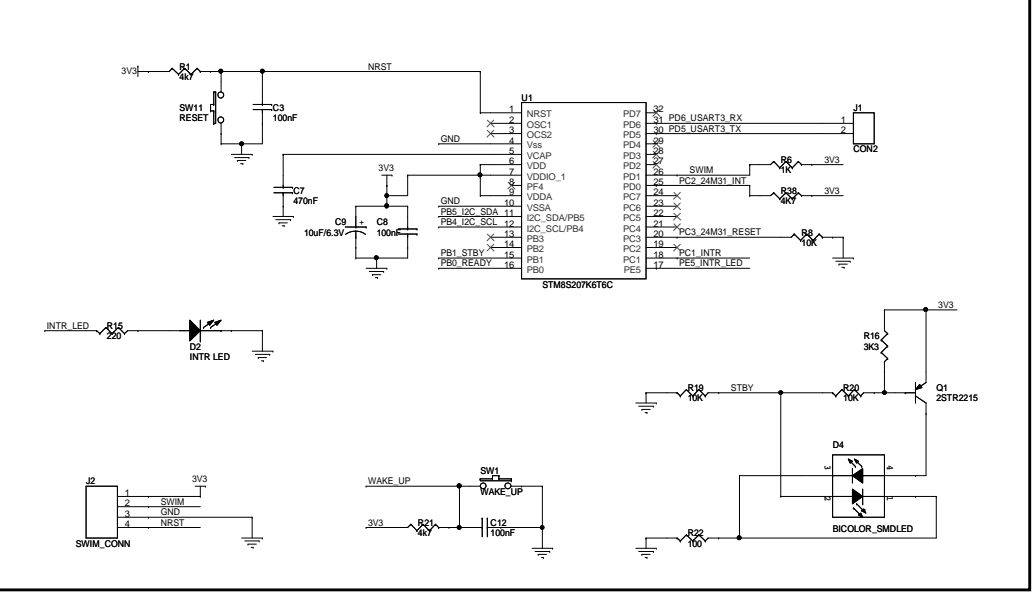

## KEYSCAN CIRCUIT

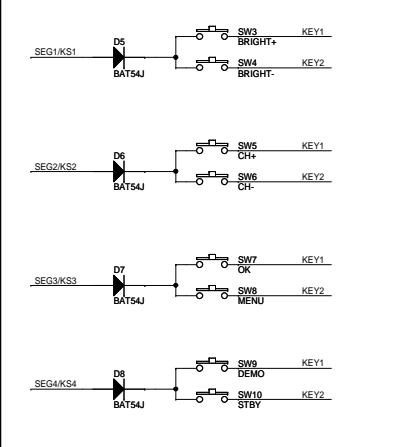

## CONNECTORS

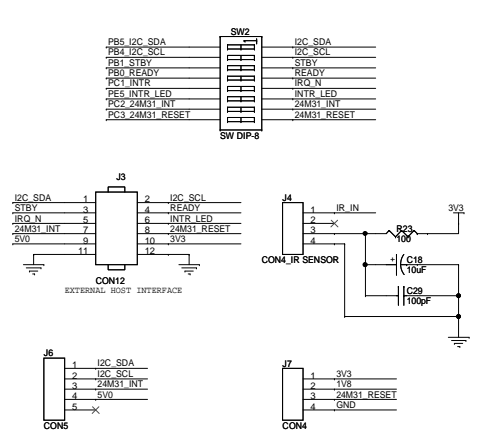

## DISCRETE LED

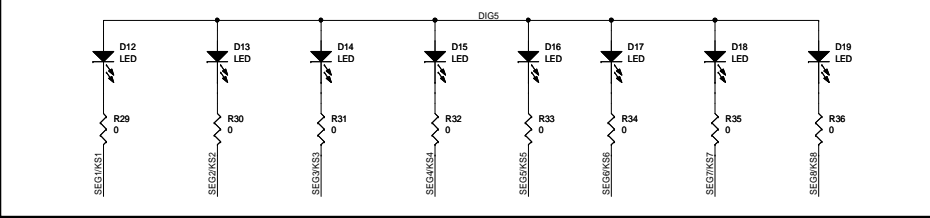

## SEVEN SEGMENT LED

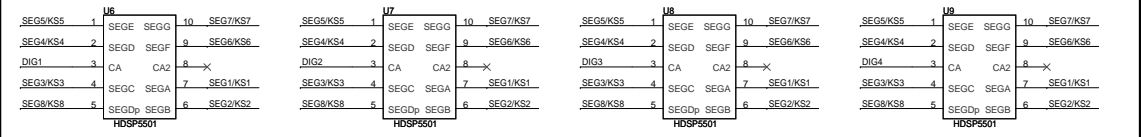

## POWER SUPPLY SECTION

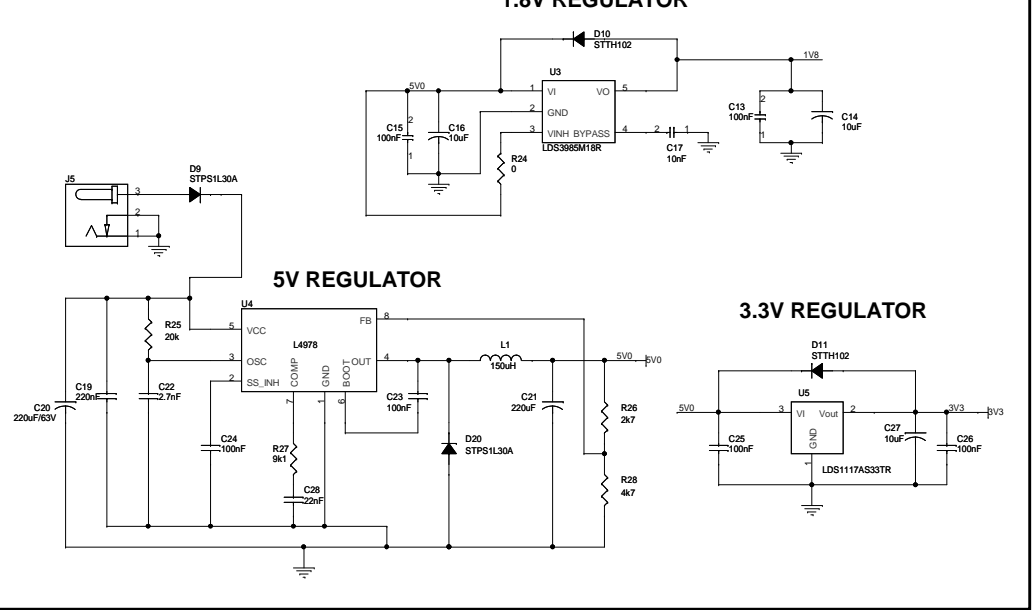

STMicroelectronics and/or its licensors do not warrant the accuracy or completeness of this specification or any information contained therein. STMicroelectronics and/or its licensors do not warrant that this design will meet the specifications, will be suitable for your application or fit for any particular purpose, or will operate in an implementation. STMicroelectronics and/or its licensors do not warrant that the design is production worthy. You should completely validate and test your design implementation to confirm the system functionality for your application.

<b>WWW.ST.COM</b>			
<b>FRONT PANEL DISPLAY_STLED325</b>			
File	Document Number	Rev	1
Size	Document Number	Rev	1
<b>STEVAL-IL029V1</b>			1
Date:	Tuesday, April 13, 2010	Sheet	1 of 1