

STEVAL-IPE005V1 - STPM01 programmer kit schematics

Microcontroller and main parts schematic

Microcontroller and main parts schematic

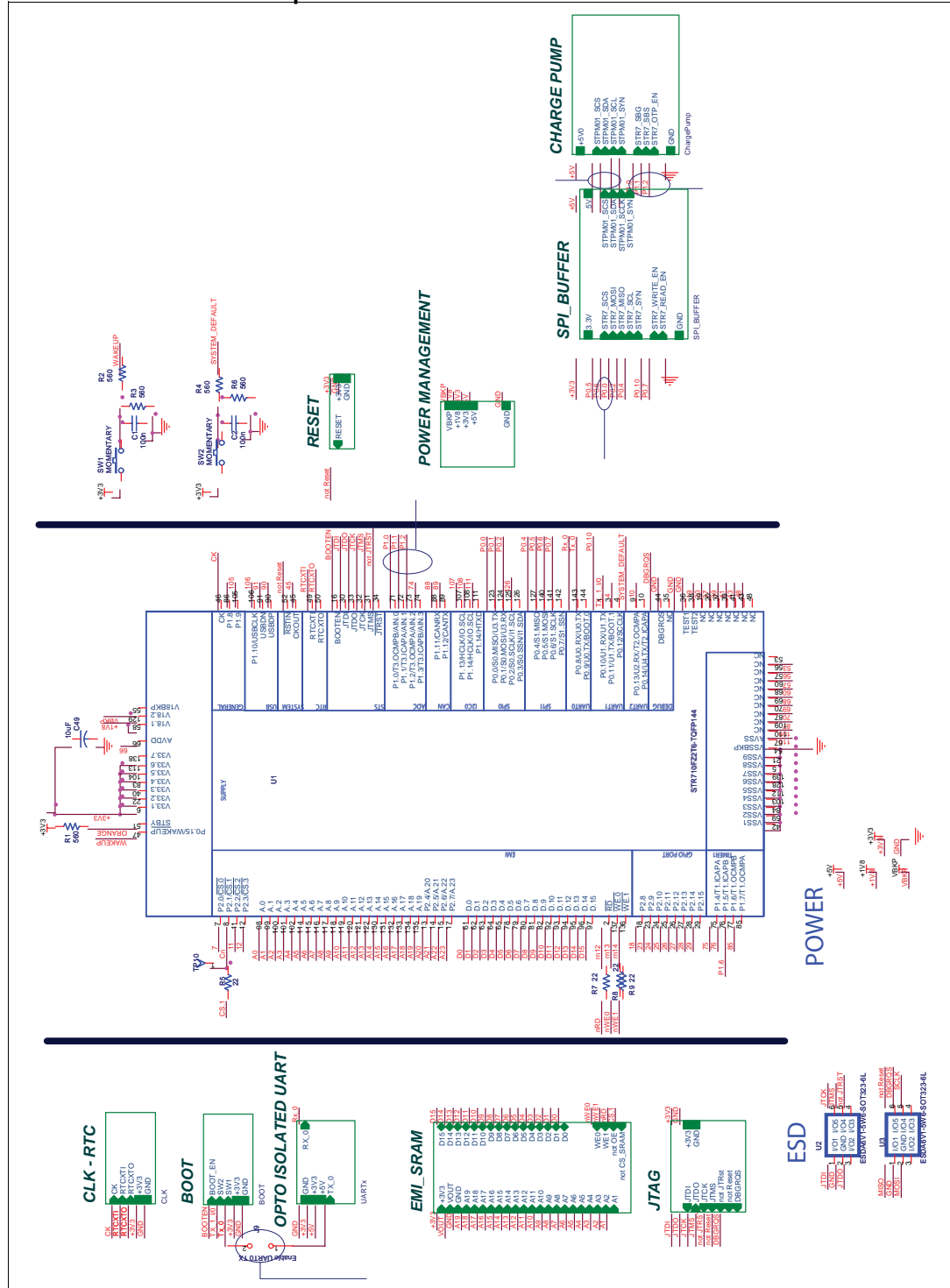

Power management

Power management schematic

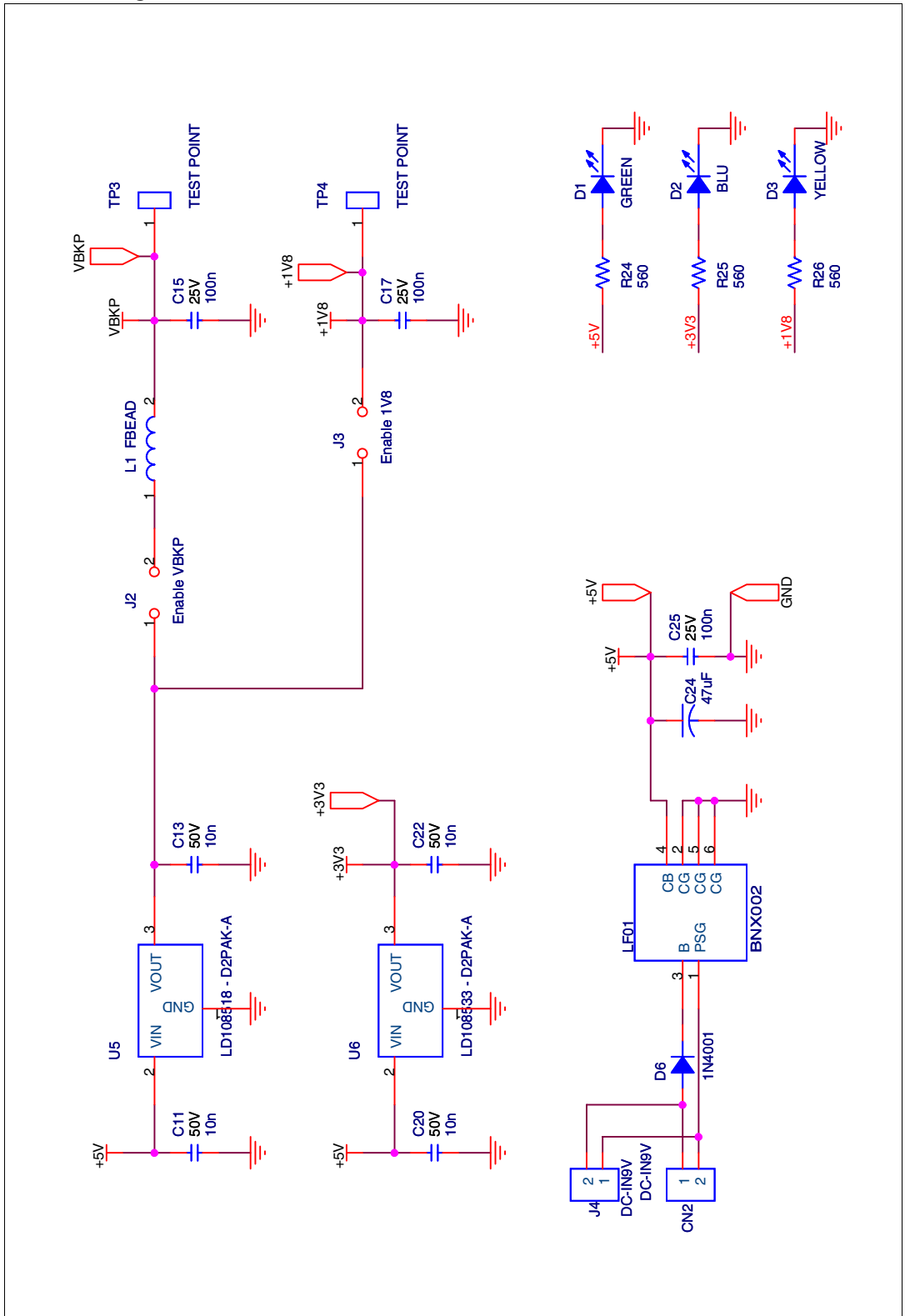

Reset and clock circuits

Reset and clock circuits

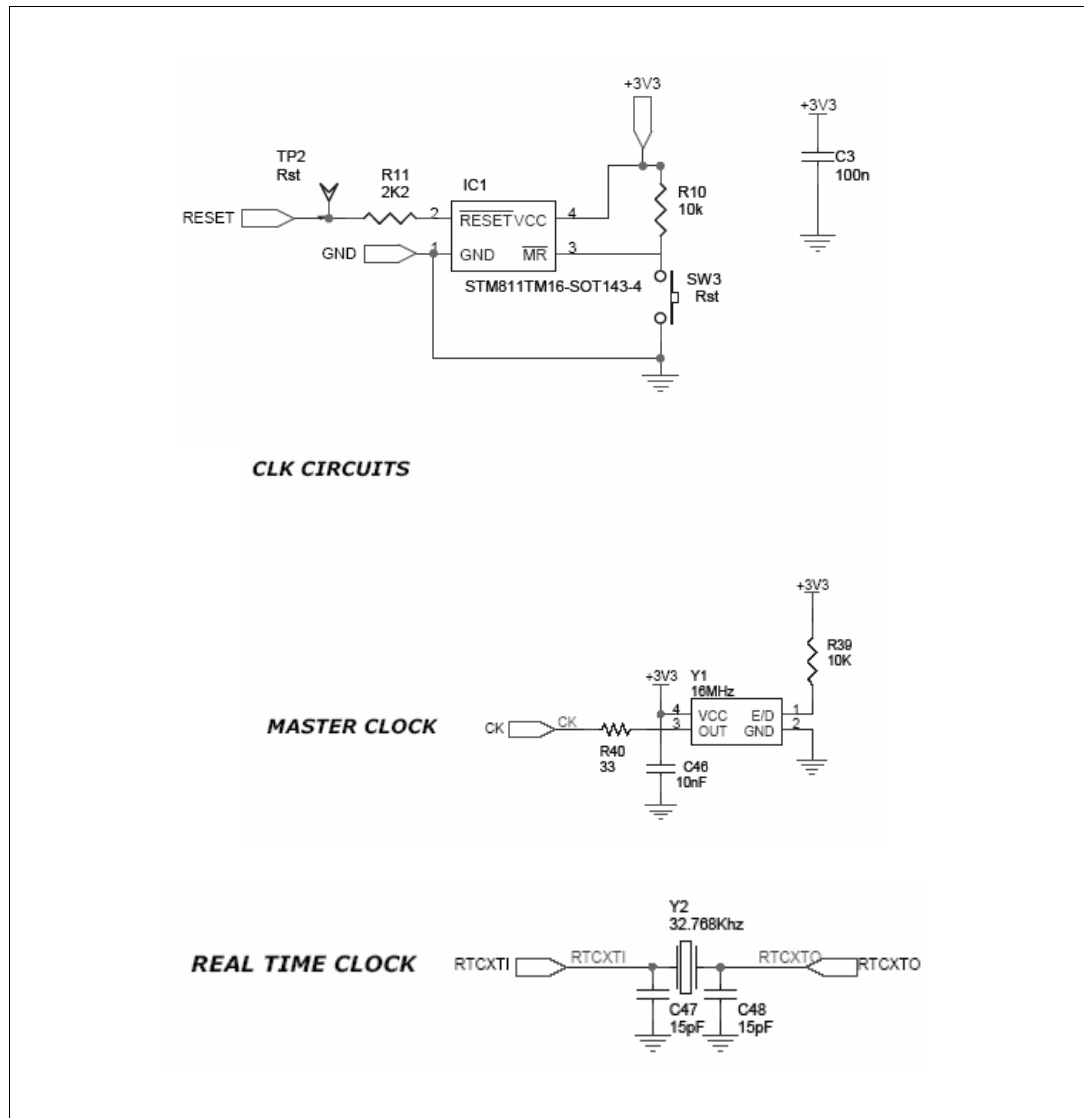

Boot management and Jtag circuit

Boot management and Jtag circuits

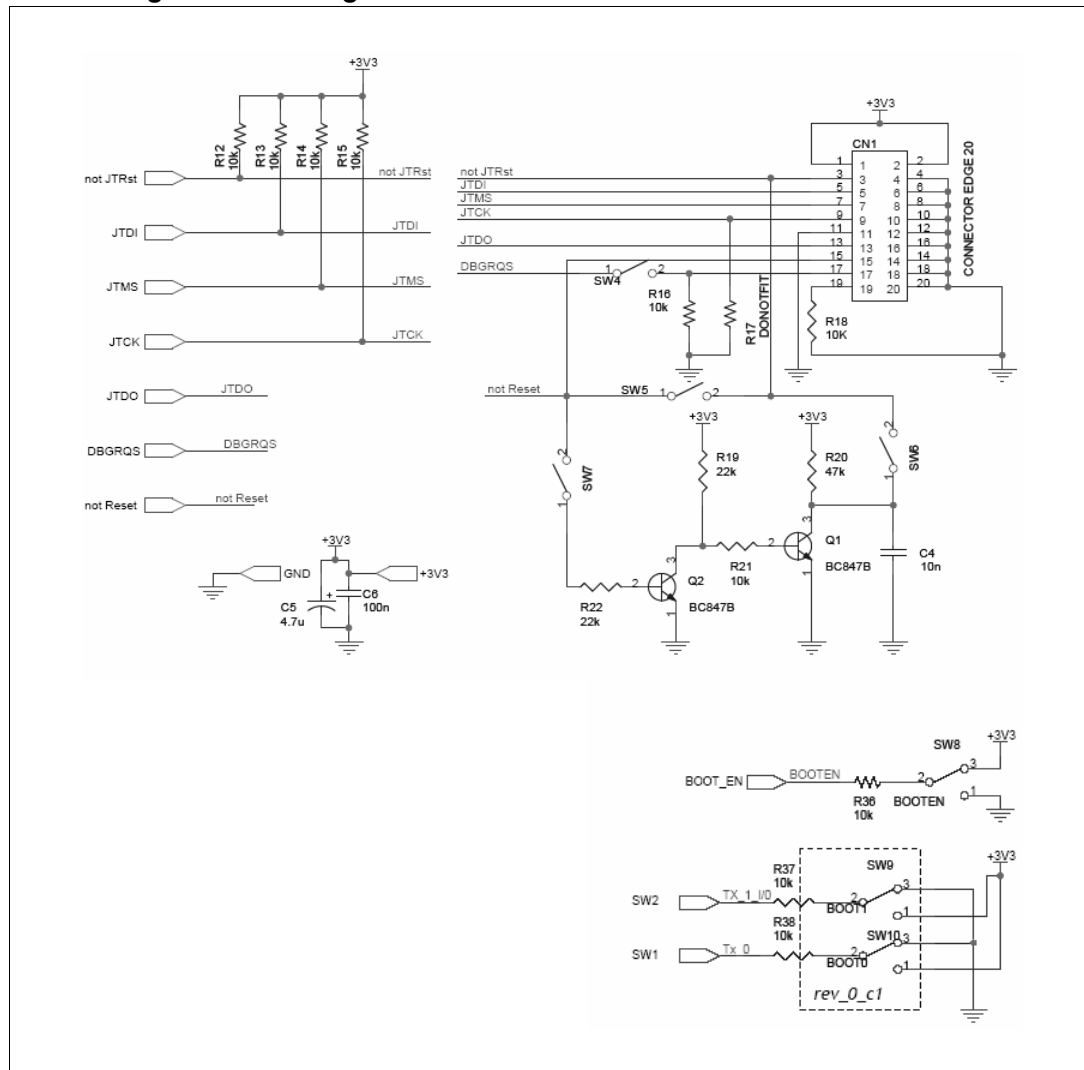

Opto-isolated UART

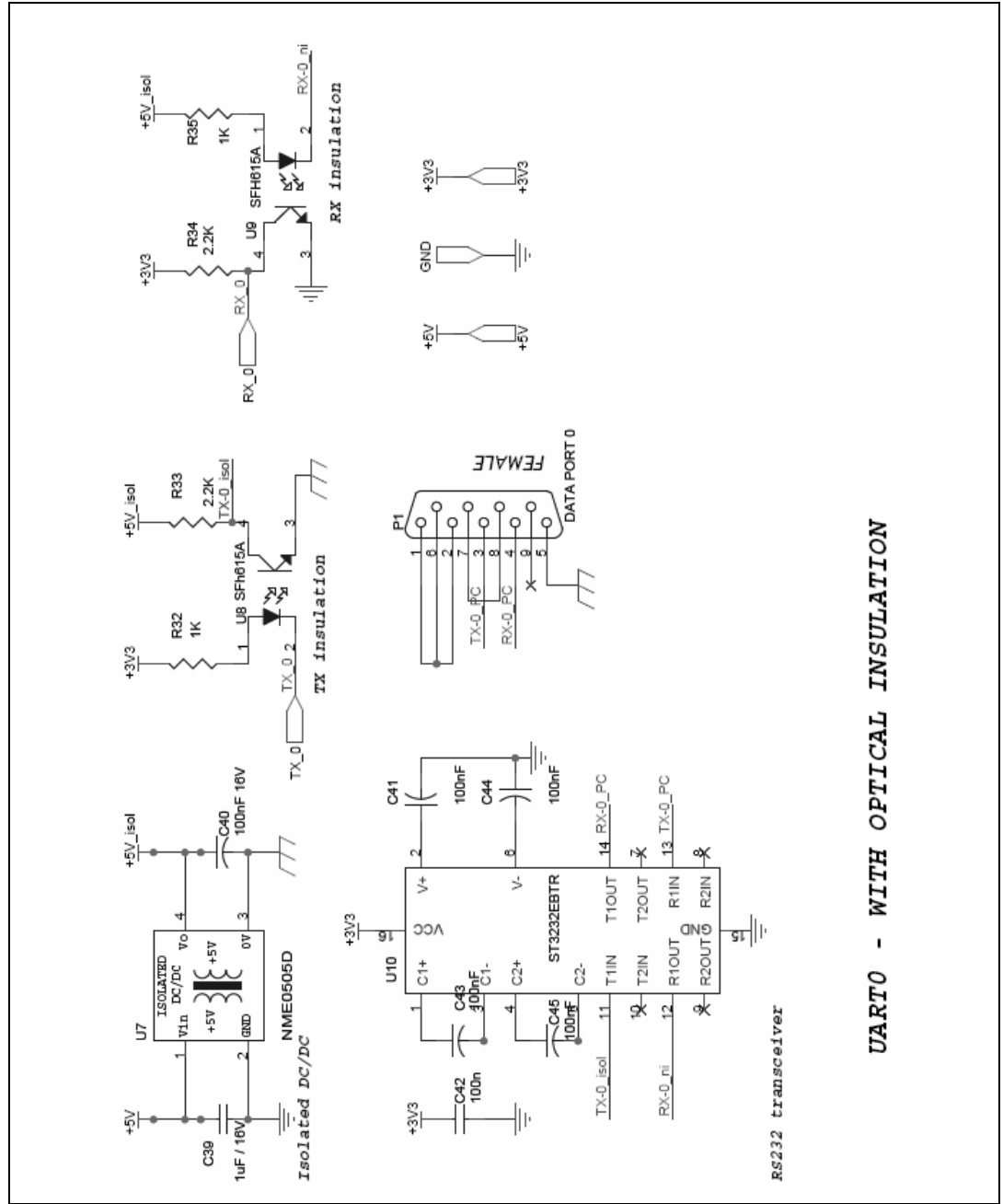

External RAM memory

External RAM memory

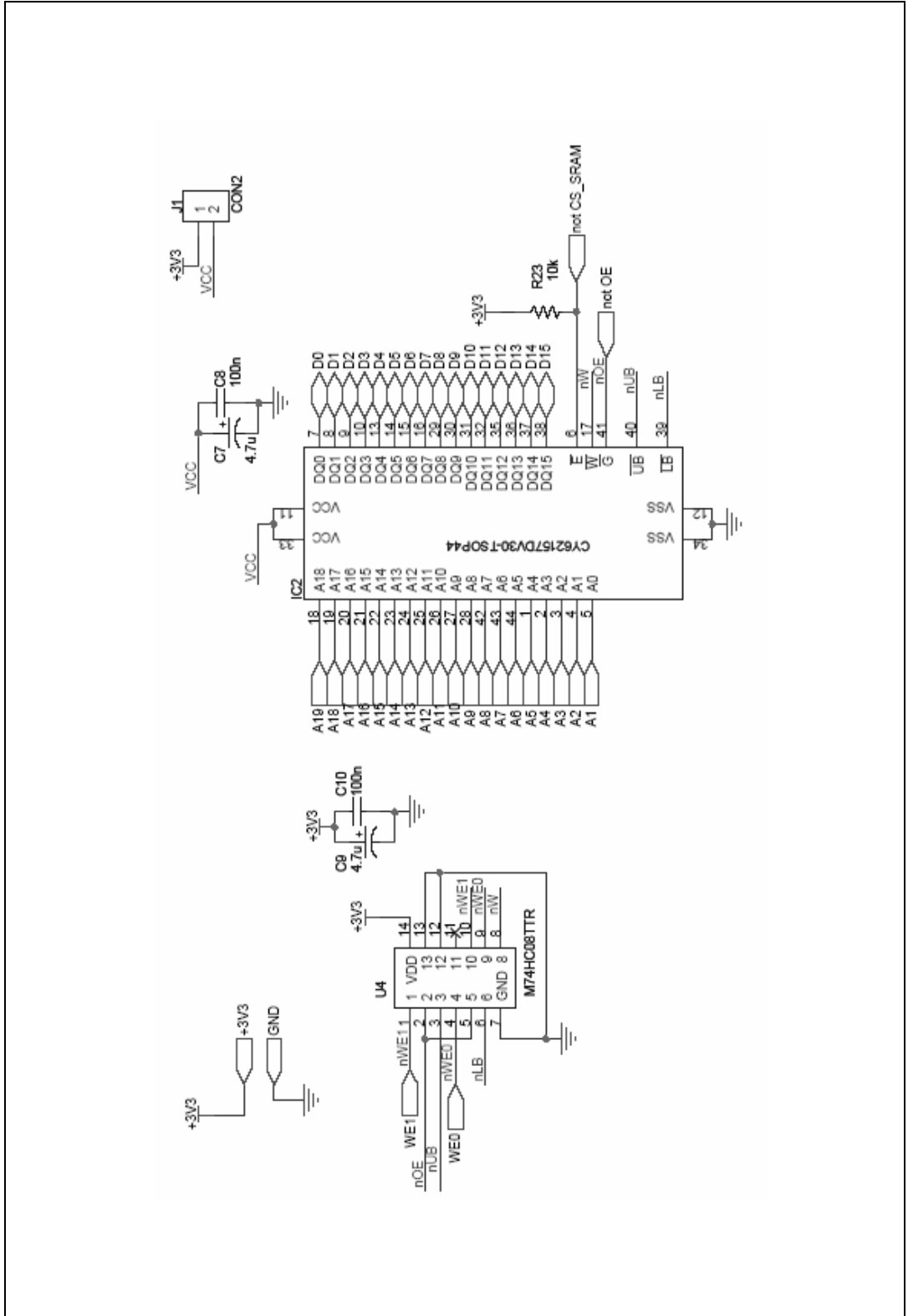

SPI signals buffering

SPI signals buffering

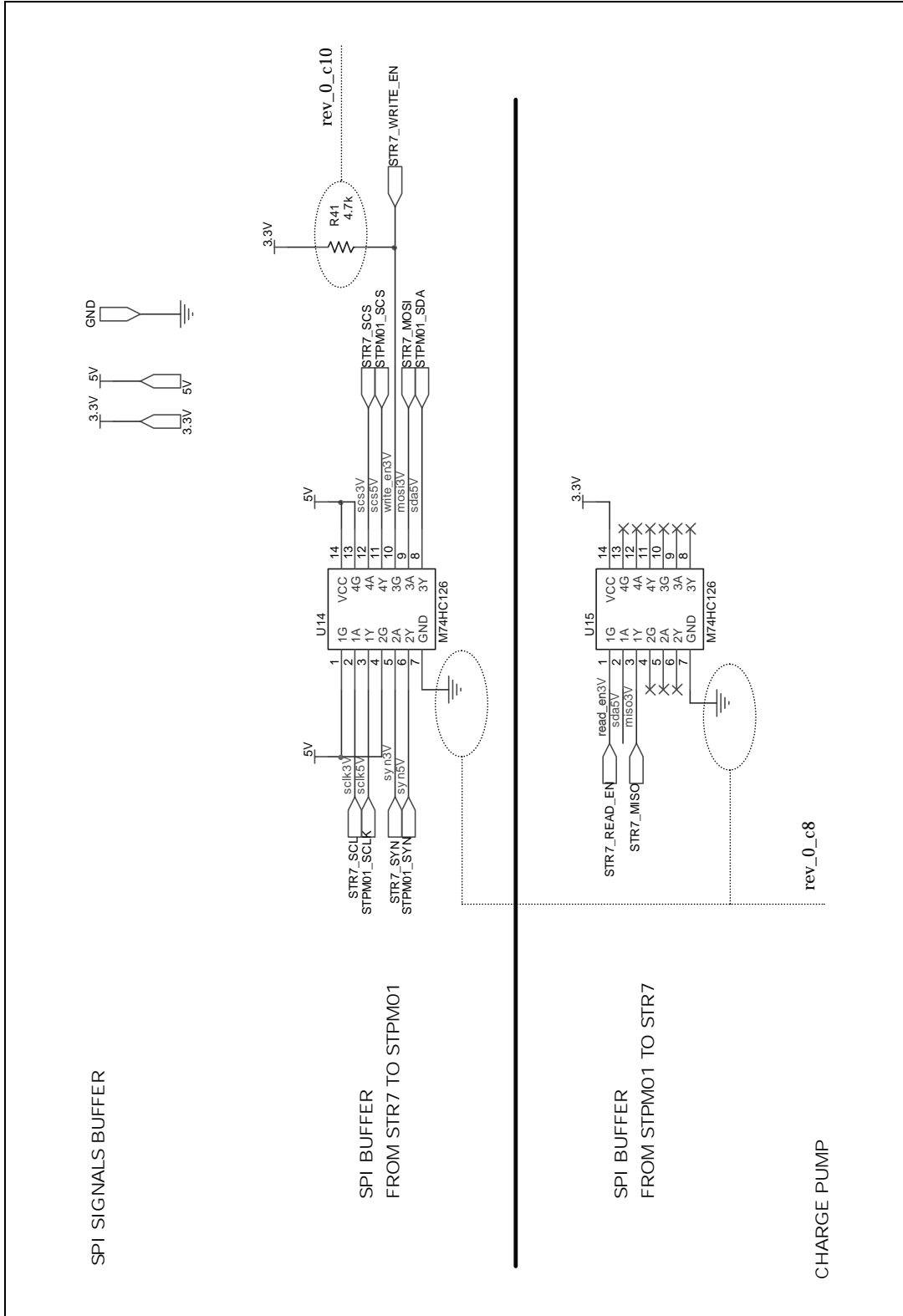

Charge pump and SPI connector

Charge pump and SPI connector

