



## STEVAL-IPP001V2

Complete solution for power line communication in  
metering applications

Data brief

### Features

- Energy consumption measured by external metering board
- Power line communication up to 28.8 kbps
- LCD display to show electrical parameters of energy consumption
- USB and RS232/IrDA connectivity
- Optional ZigBee communication capability
- Optional MEMS module support
- Expansion capability for smartcard interface
- RoHS compliant

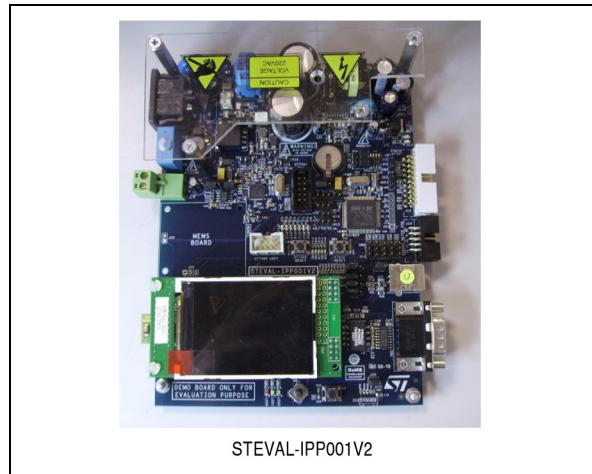

### Description

The STEVAL-IPP001V2 demonstration board is based on the STM32F10xxx microcontroller, ST7580 PLM module and STPMC1 polyphase energy-metering IC.

The STEVAL-IPP001V2 demonstration board implements a PLM smart-meter node which allows the public utility company to monitor energy consumption and other electrical parameters during one or more phases.

The voltage, current, power, power factor, THD, active and reactive energy and other stored information can be shown on an LCD locally or sent to a PLM data concentrator through a power line communication network.

# 1 Schematic diagrams

Figure 1. Top

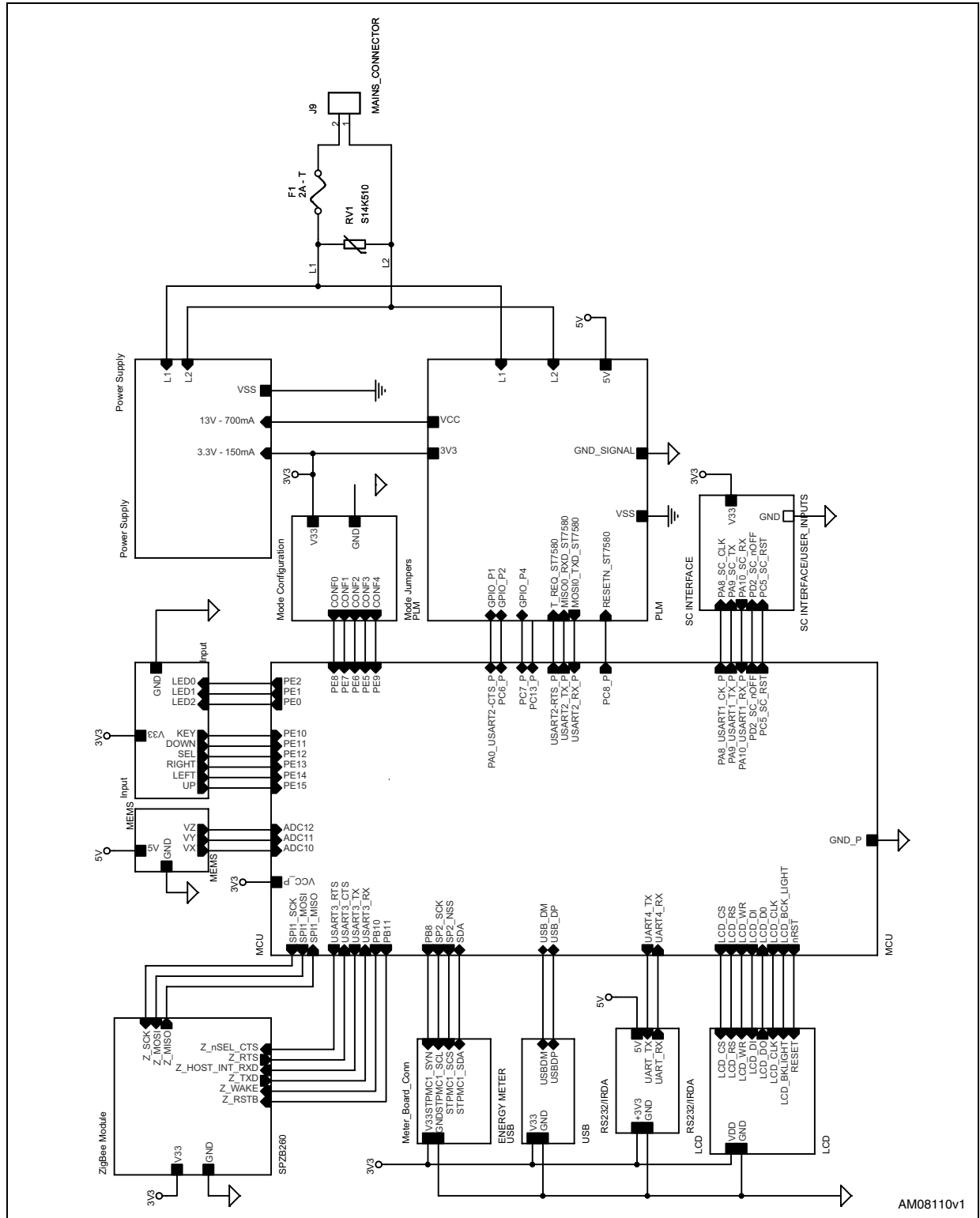
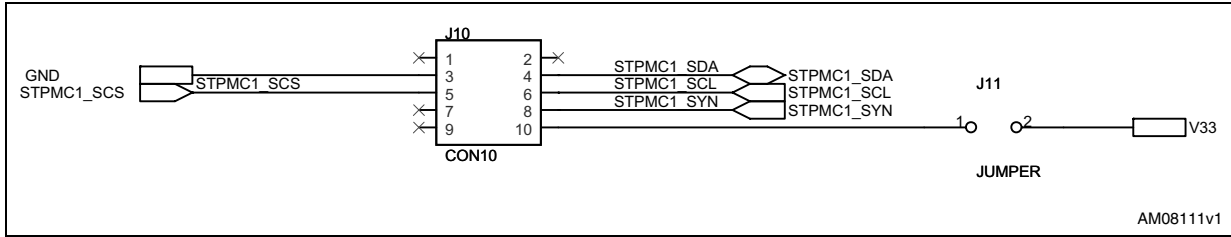
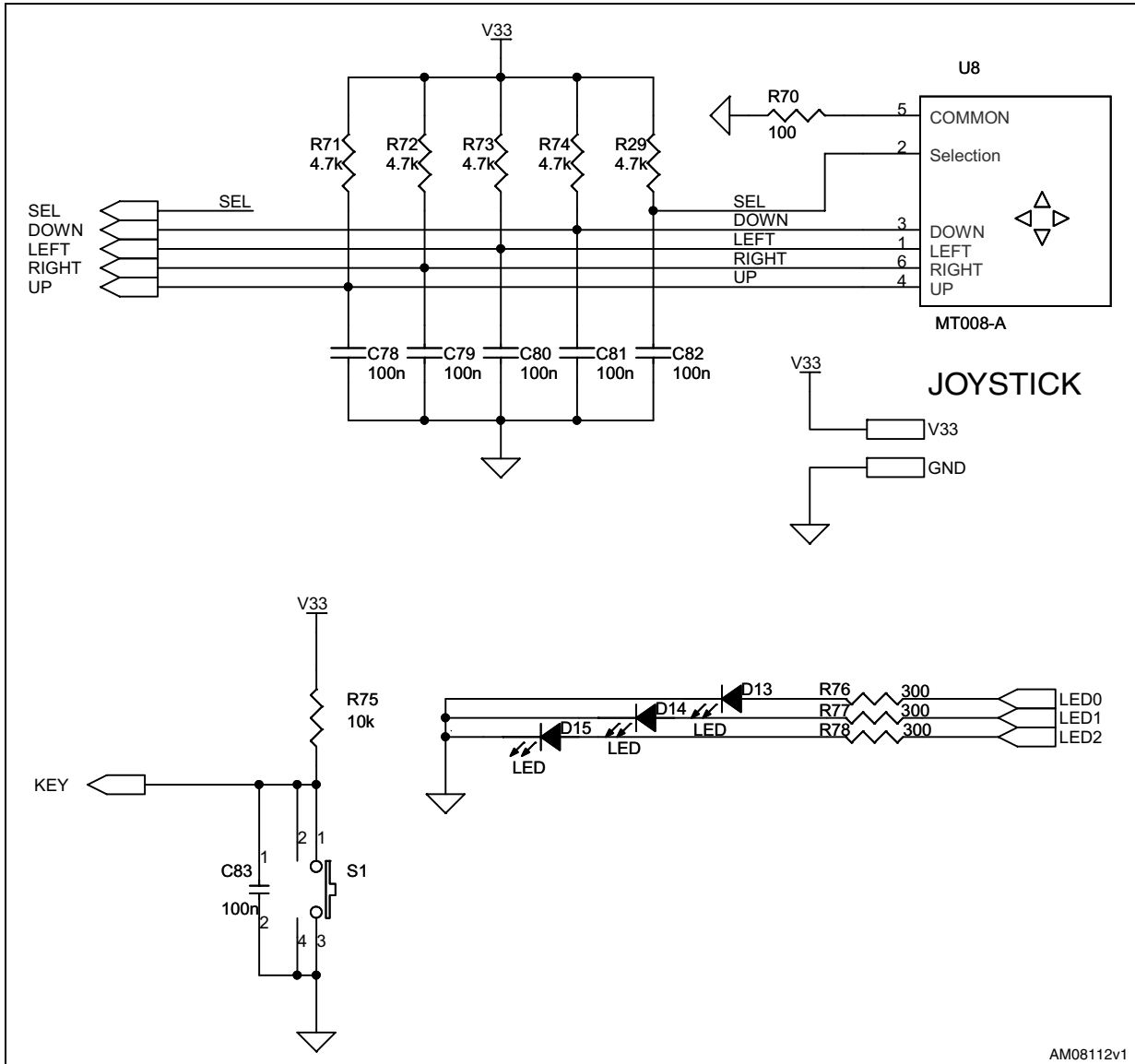

Figure 2. Metering board connector



AM08111v1

Figure 3. User interface



AM08112v1





Figure 4. LCD connector section

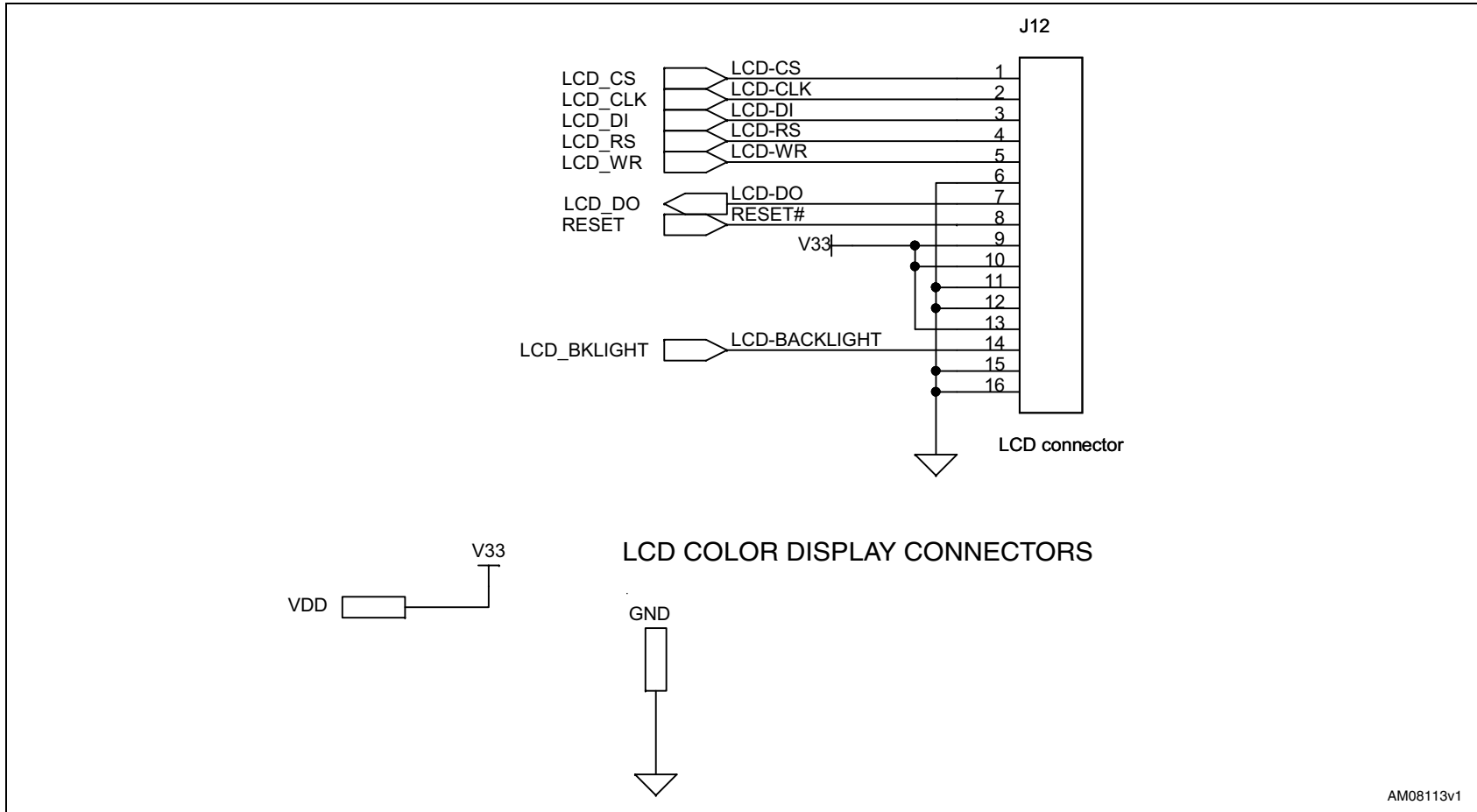
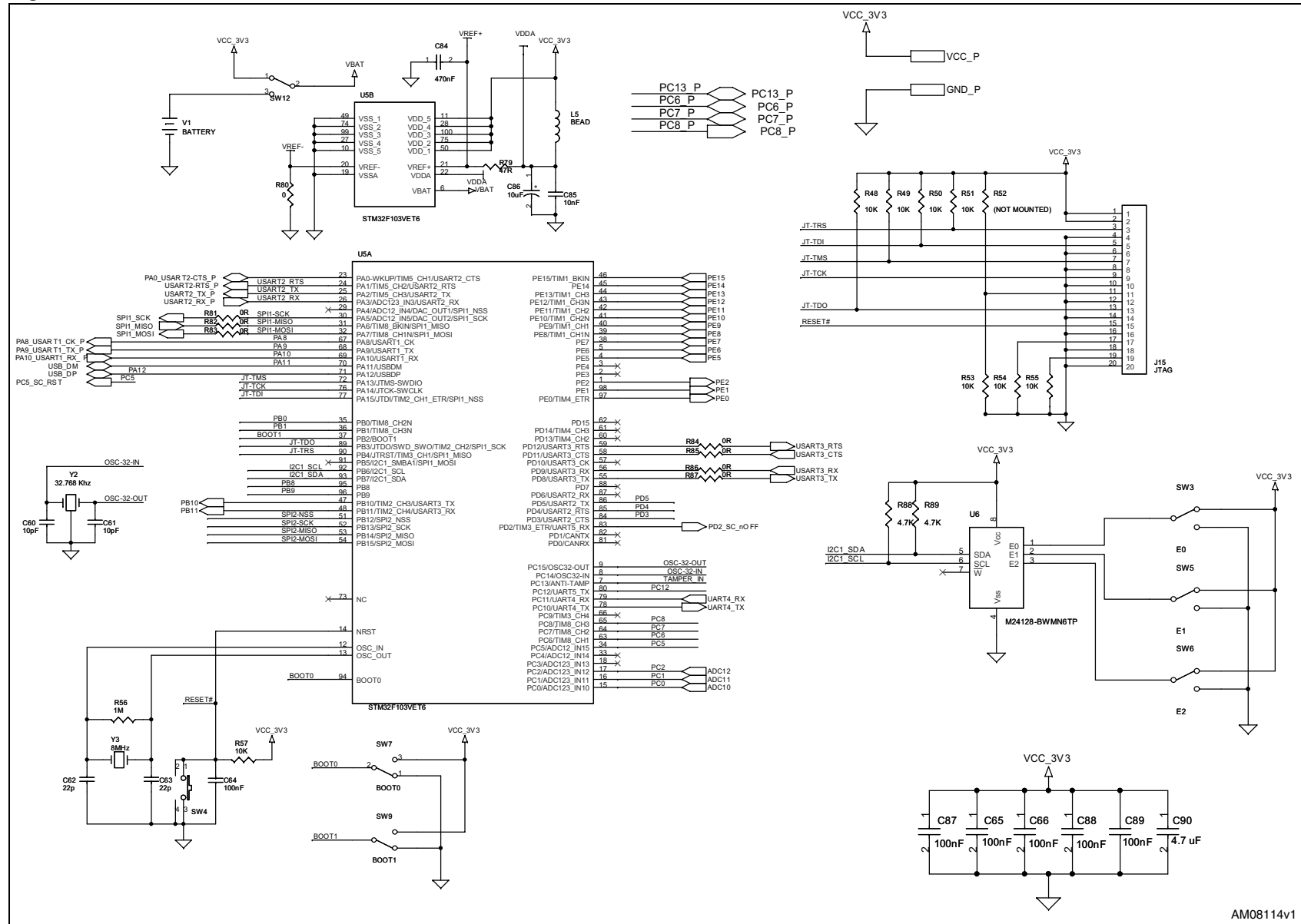



Figure 5. MCU schematic



AM08114v1

Figure 6. RTC calibration, meter and LCD level

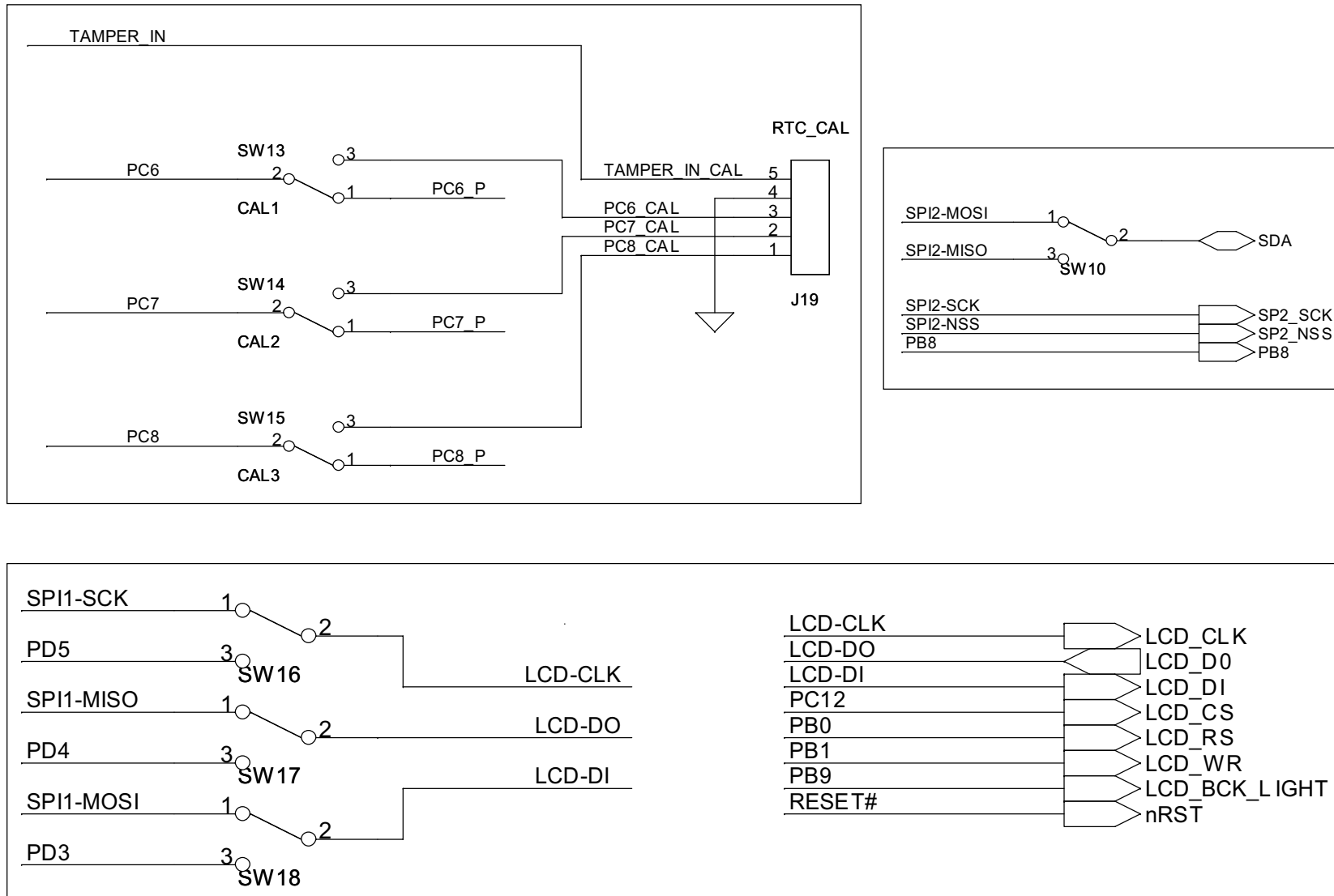

Figure 7. MEMS module connector

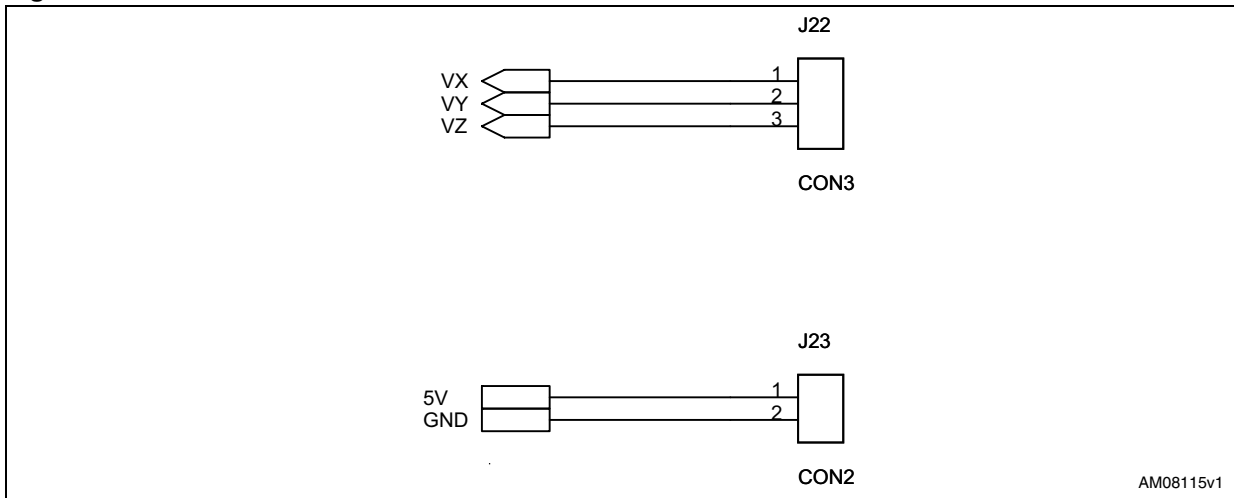

Figure 8. General purpose configuration jumpers

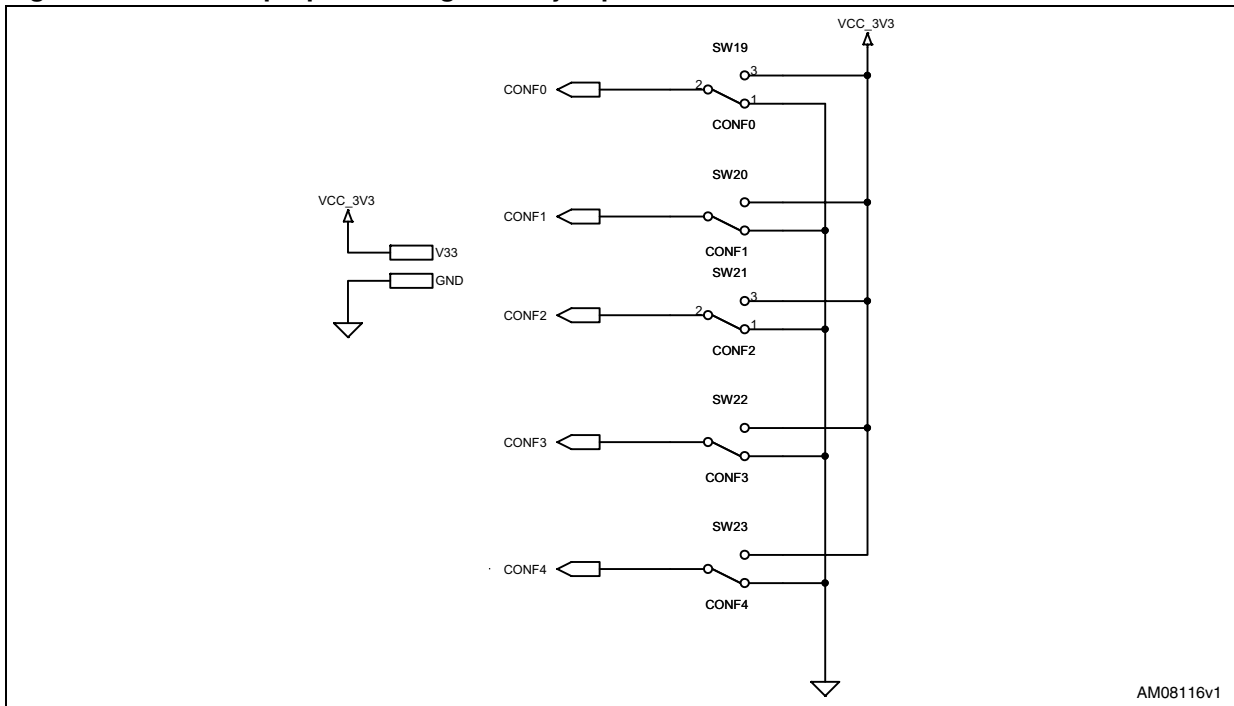
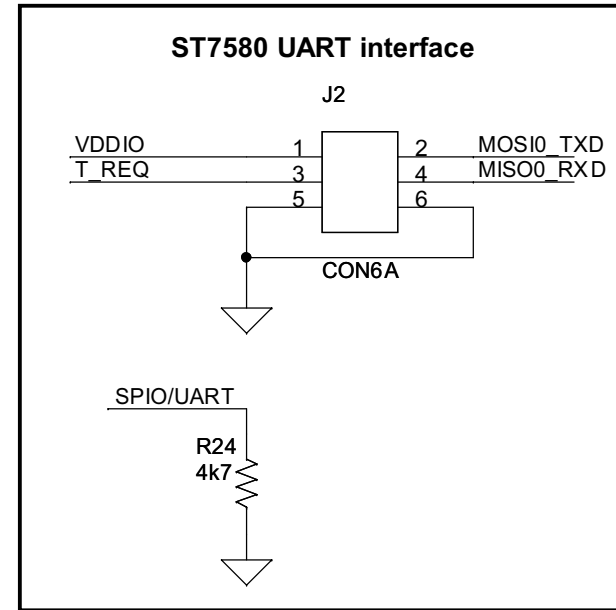
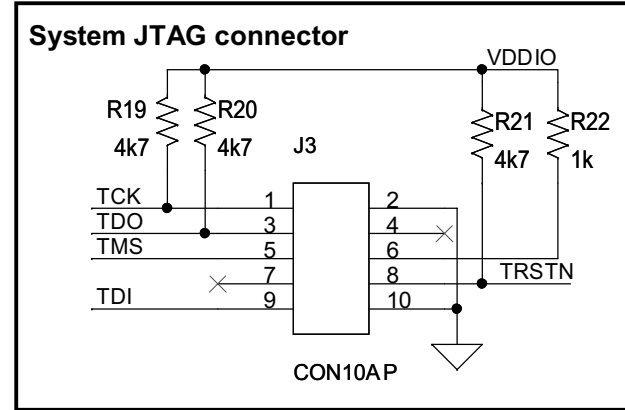
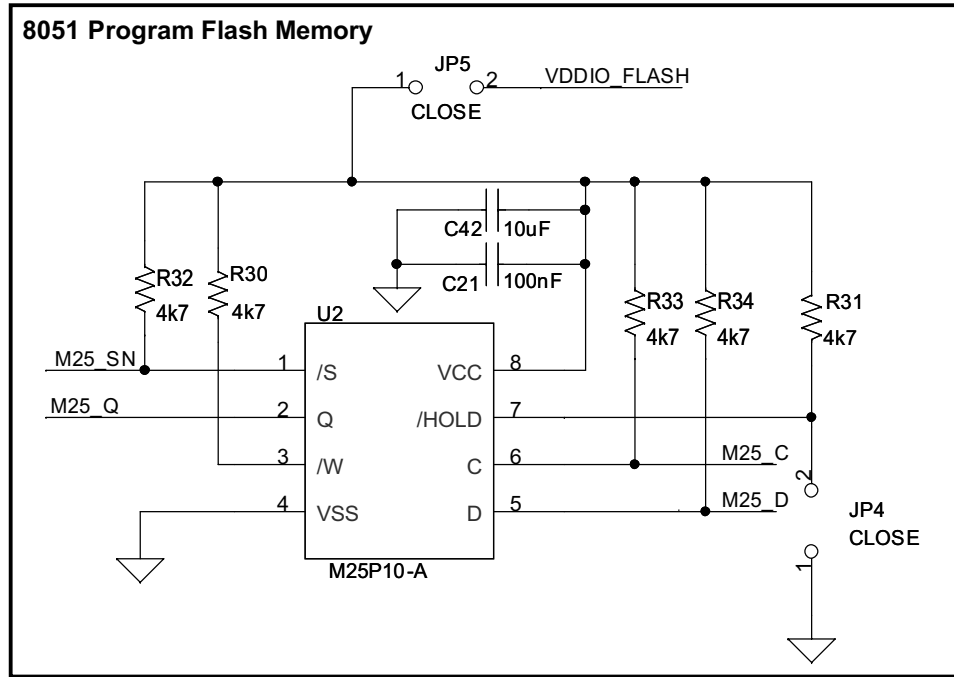







Figure 10. System JTAG connector, ST7580 UART interface, and 8051 program Flash memory



AM08124v1



Figure 11. Non-isolated zero-crossing, ST7580 reset button, current limit setting, and microcontroller connection

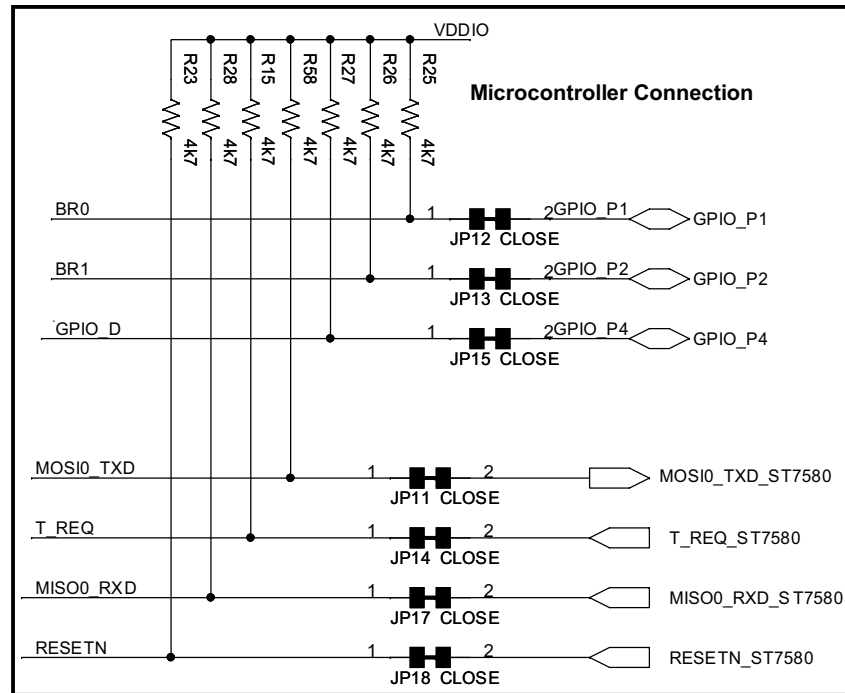
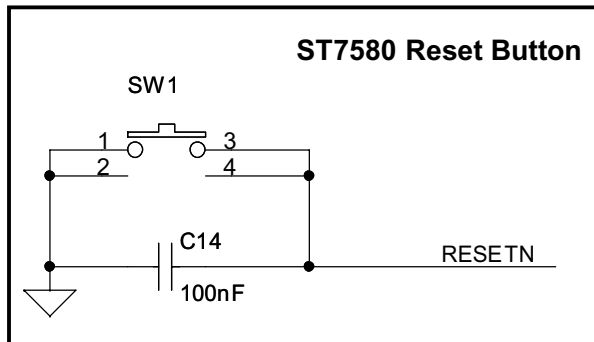
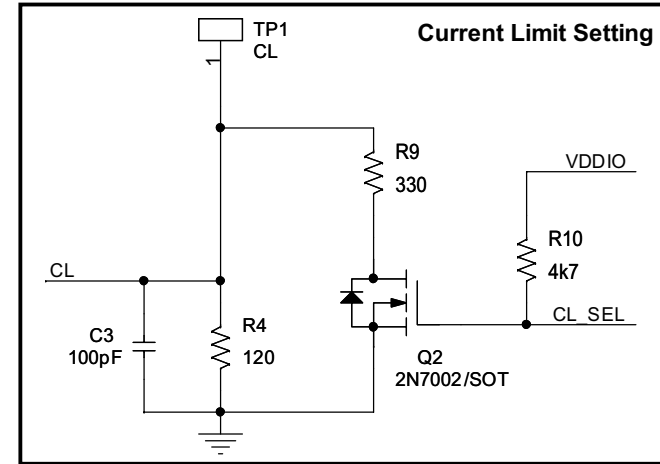
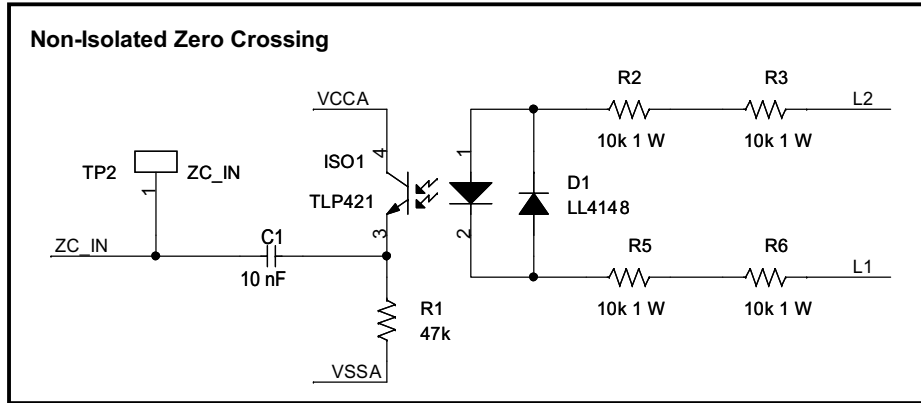



Figure 12. Power supply (part 1)

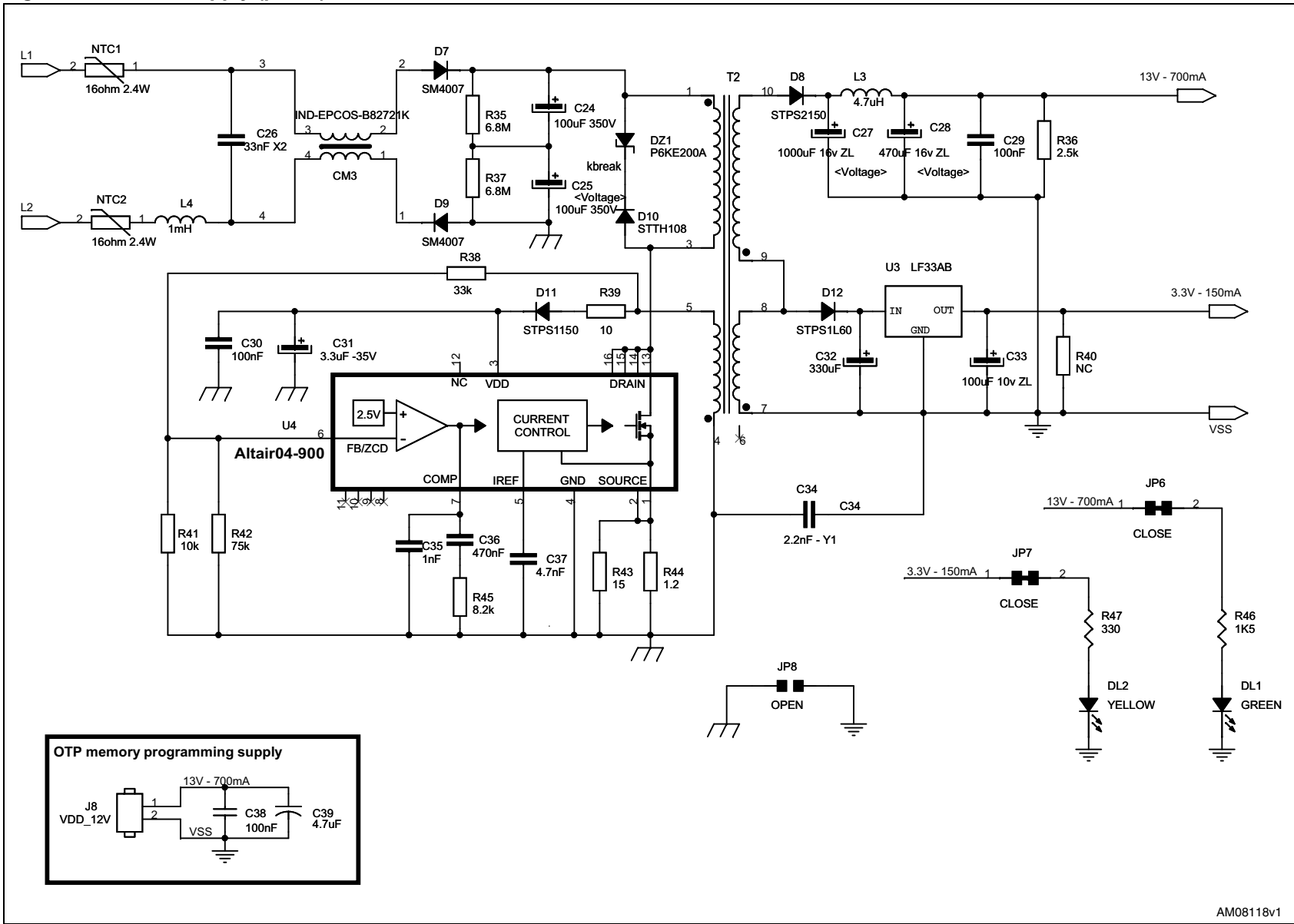
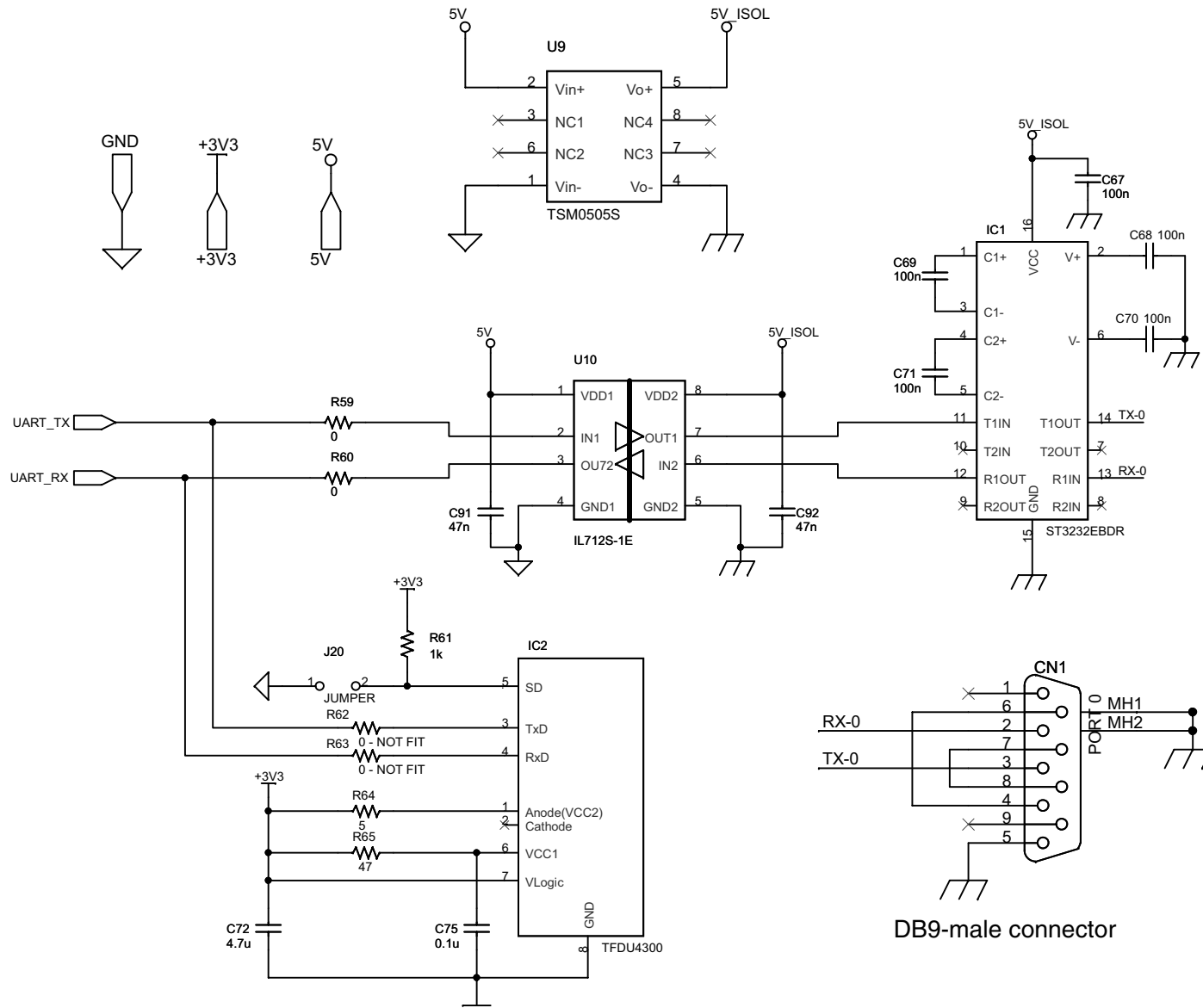



Figure 13. Power supply (part 2)



Doc ID 022350 Rev 1

12/16

AM08119v1

Figure 14. Power supply (part 3)

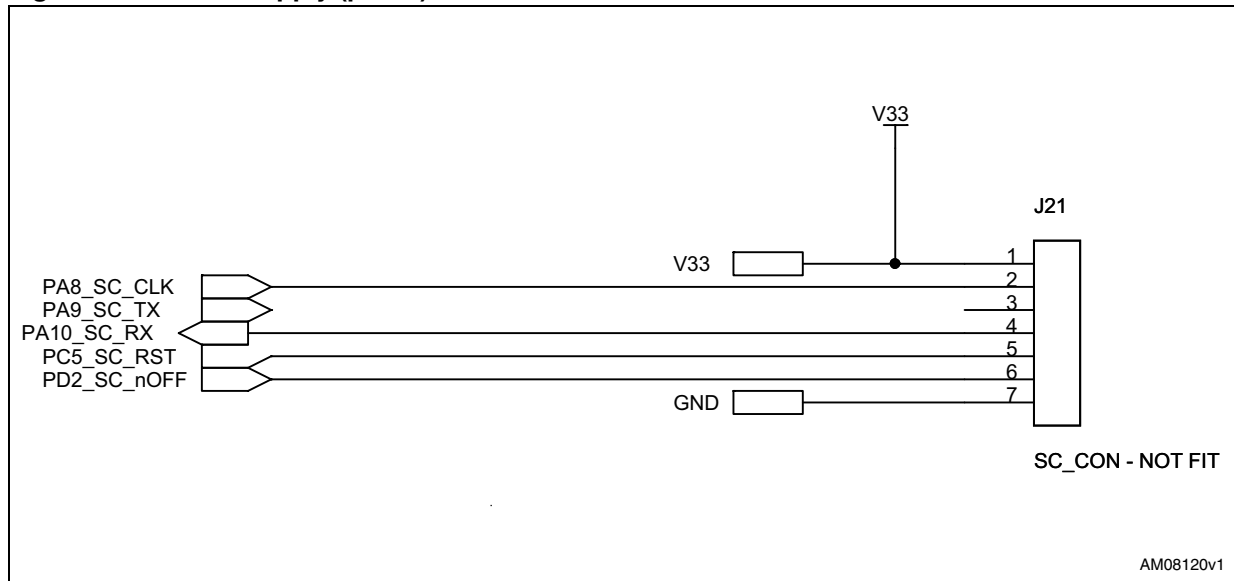

Figure 15. ZigBee module connector

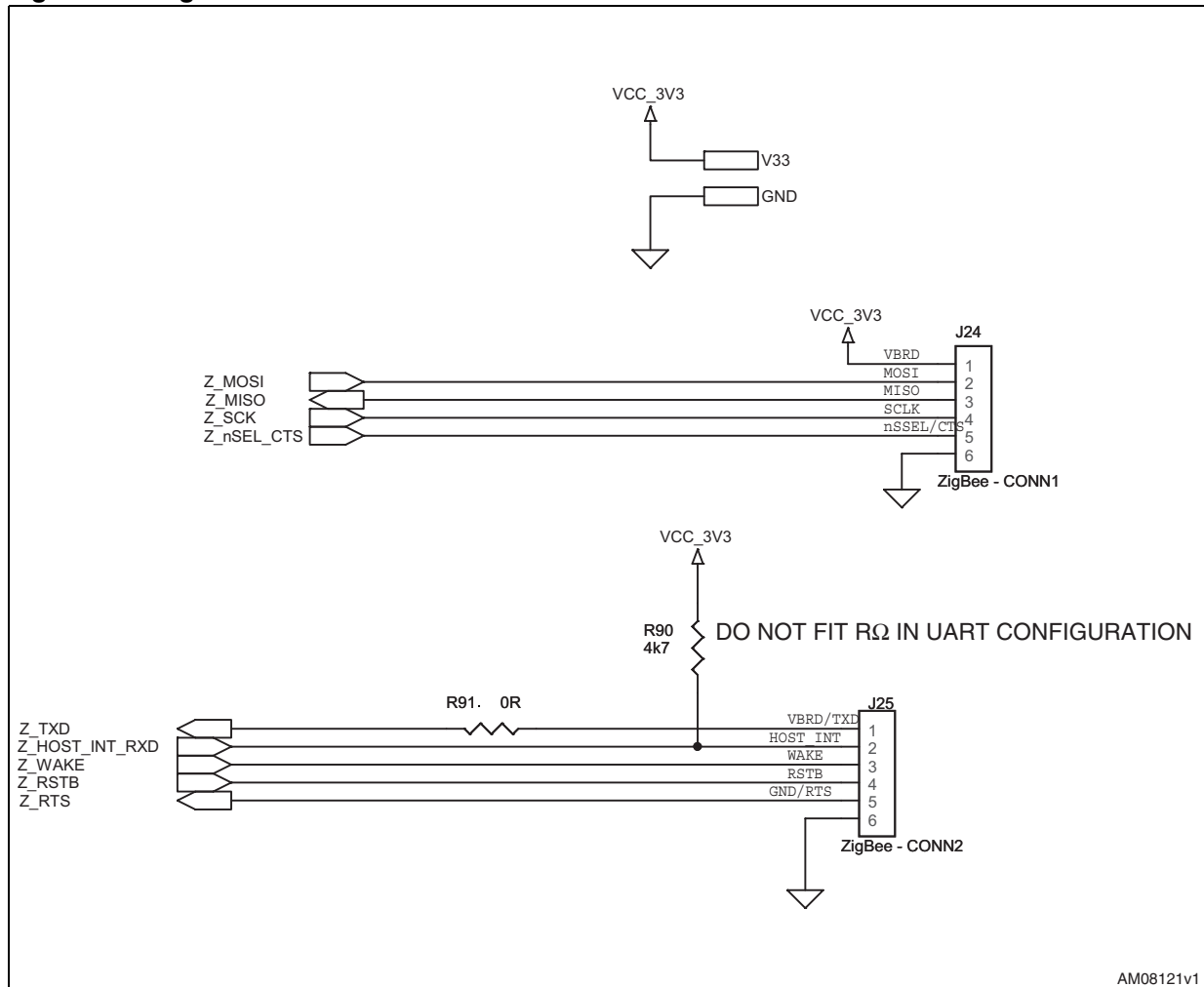
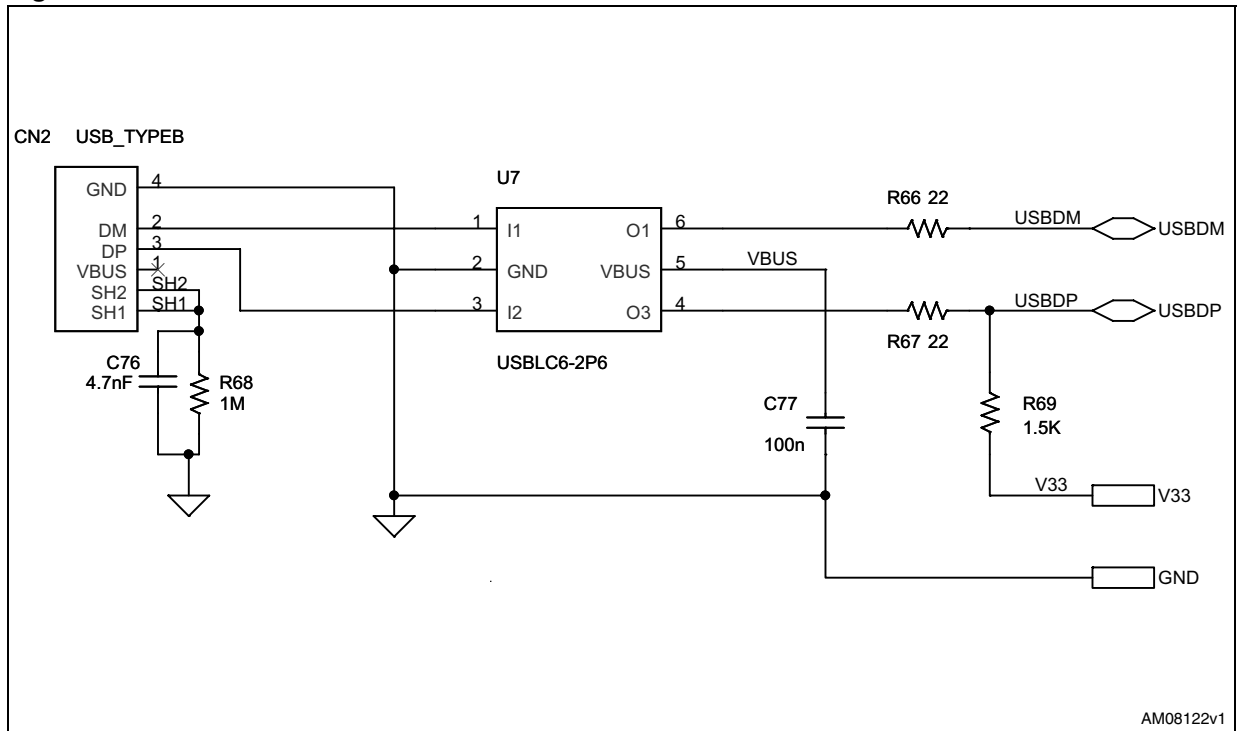

Figure 16. USB connector



## 2 Revision history

Table 1. Document revision history

Date	Revision	Changes
20-Oct-2011	1	Initial release.

---

**Please Read Carefully:**

Information in this document is provided solely in connection with ST products. STMicroelectronics NV and its subsidiaries ("ST") reserve the right to make changes, corrections, modifications or improvements, to this document, and the products and services described herein at any time, without notice.

All ST products are sold pursuant to ST's terms and conditions of sale.

Purchasers are solely responsible for the choice, selection and use of the ST products and services described herein, and ST assumes no liability whatsoever relating to the choice, selection or use of the ST products and services described herein.

No license, express or implied, by estoppel or otherwise, to any intellectual property rights is granted under this document. If any part of this document refers to any third party products or services it shall not be deemed a license grant by ST for the use of such third party products or services, or any intellectual property contained therein or considered as a warranty covering the use in any manner whatsoever of such third party products or services or any intellectual property contained therein.

**UNLESS OTHERWISE SET FORTH IN ST'S TERMS AND CONDITIONS OF SALE ST DISCLAIMS ANY EXPRESS OR IMPLIED WARRANTY WITH RESPECT TO THE USE AND/OR SALE OF ST PRODUCTS INCLUDING WITHOUT LIMITATION IMPLIED WARRANTIES OF MERCHANTABILITY, FITNESS FOR A PARTICULAR PURPOSE (AND THEIR EQUIVALENTS UNDER THE LAWS OF ANY JURISDICTION), OR INFRINGEMENT OF ANY PATENT, COPYRIGHT OR OTHER INTELLECTUAL PROPERTY RIGHT.**

**UNLESS EXPRESSLY APPROVED IN WRITING BY TWO AUTHORIZED ST REPRESENTATIVES, ST PRODUCTS ARE NOT RECOMMENDED, AUTHORIZED OR WARRANTED FOR USE IN MILITARY, AIR CRAFT, SPACE, LIFE SAVING, OR LIFE SUSTAINING APPLICATIONS, NOR IN PRODUCTS OR SYSTEMS WHERE FAILURE OR MALFUNCTION MAY RESULT IN PERSONAL INJURY, DEATH, OR SEVERE PROPERTY OR ENVIRONMENTAL DAMAGE. ST PRODUCTS WHICH ARE NOT SPECIFIED AS "AUTOMOTIVE GRADE" MAY ONLY BE USED IN AUTOMOTIVE APPLICATIONS AT USER'S OWN RISK.**

Resale of ST products with provisions different from the statements and/or technical features set forth in this document shall immediately void any warranty granted by ST for the ST product or service described herein and shall not create or extend in any manner whatsoever, any liability of ST.

ST and the ST logo are trademarks or registered trademarks of ST in various countries.

Information in this document supersedes and replaces all information previously supplied.

The ST logo is a registered trademark of STMicroelectronics. All other names are the property of their respective owners.

© 2011 STMicroelectronics - All rights reserved

STMicroelectronics group of companies

Australia - Belgium - Brazil - Canada - China - Czech Republic - Finland - France - Germany - Hong Kong - India - Israel - Italy - Japan - Malaysia - Malta - Morocco - Philippines - Singapore - Spain - Sweden - Switzerland - United Kingdom - United States of America

[www.st.com](http://www.st.com)