



STEVAL-ISQ006V1

USB to PMBus bridge demonstration board based on the ST72F651

Data Brief

Features

- USB to PMBus bridge
- Packaged hardware board (mechanical size: 79 mm x 39 mm x 20 mm) with a USB connector
- User friendly graphical user interface (GUI) to
 - identify the connected PMBus slaves (up to four)
 - configure, control and monitor the connected slaves
 - write/ read different PMBus commands
 - poll the alert response



Description

The power management bus (PMBus) is a variant of the system management bus (SMBus) which is targeted at digital management of power supplies. Like SMBus, it is a relatively slow speed two wire communications protocol based on I²C. The PMBus protocol helps to establish the first truly open communications standard for the digital control of power systems facilitating the programming, control and real-time monitoring of compliant power conversion products.

The objective of this demonstration board is to show to the user the features and capabilities of PMBus using ST7 I2C peripheral, to support the standard PMBus commands.

This demonstration board has ST72651AR6 Microcontroller (MCU) that has an I2C peripheral. This microcontroller acts as the PMBus master. This demonstration board works with PC GUI and controls one or more PMBus compatible slaves connected on the shared bus. Even though its main purpose is to interface with ST PMBus devices (PM881x), it could be used to interface with other devices making use of the supported set of command.

The firmware of this application performs the PMBus bus protocols mentioned in PMBus™ power system management protocol specification v1.1. The firmware is in C language.

1 Circuit schematics

Figure 1. Microcontroller section

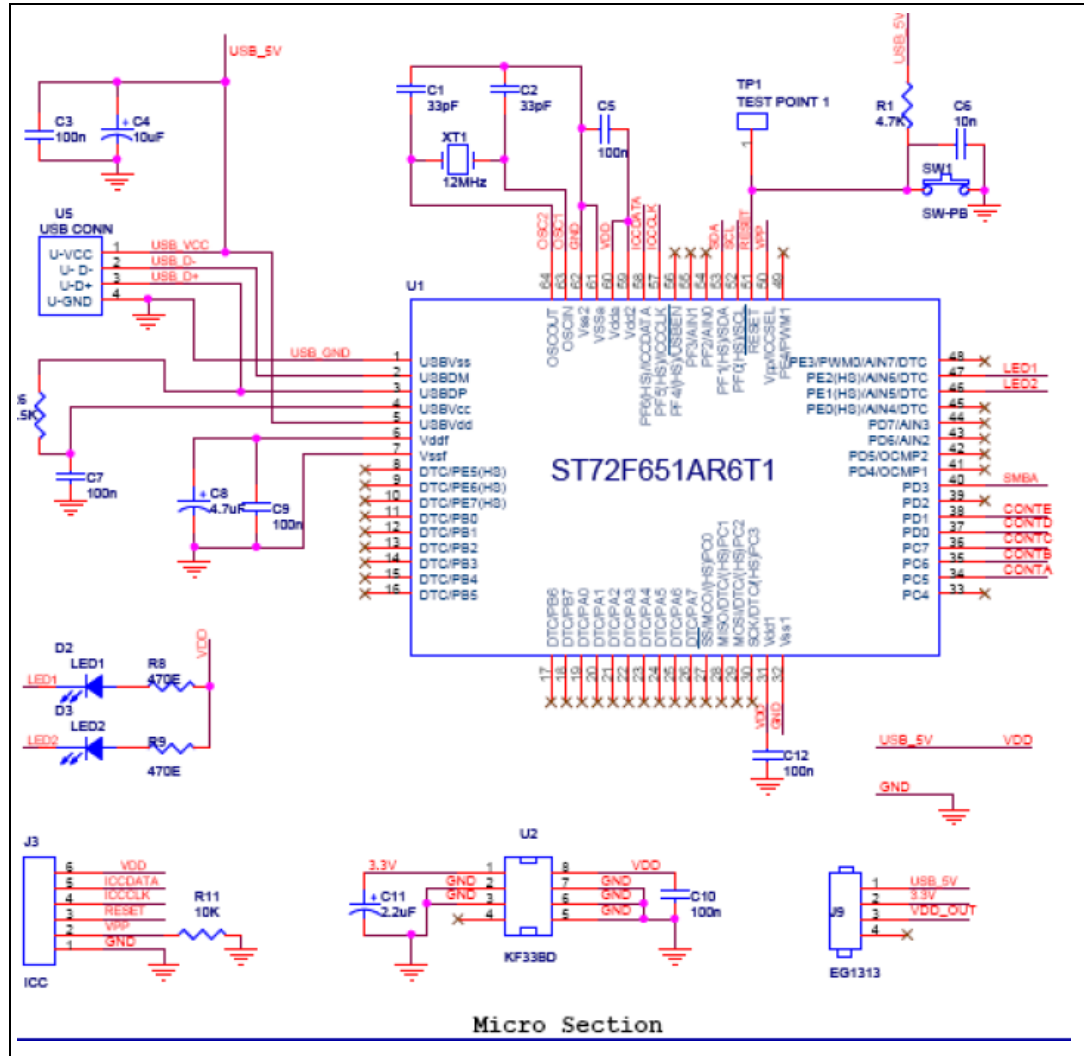
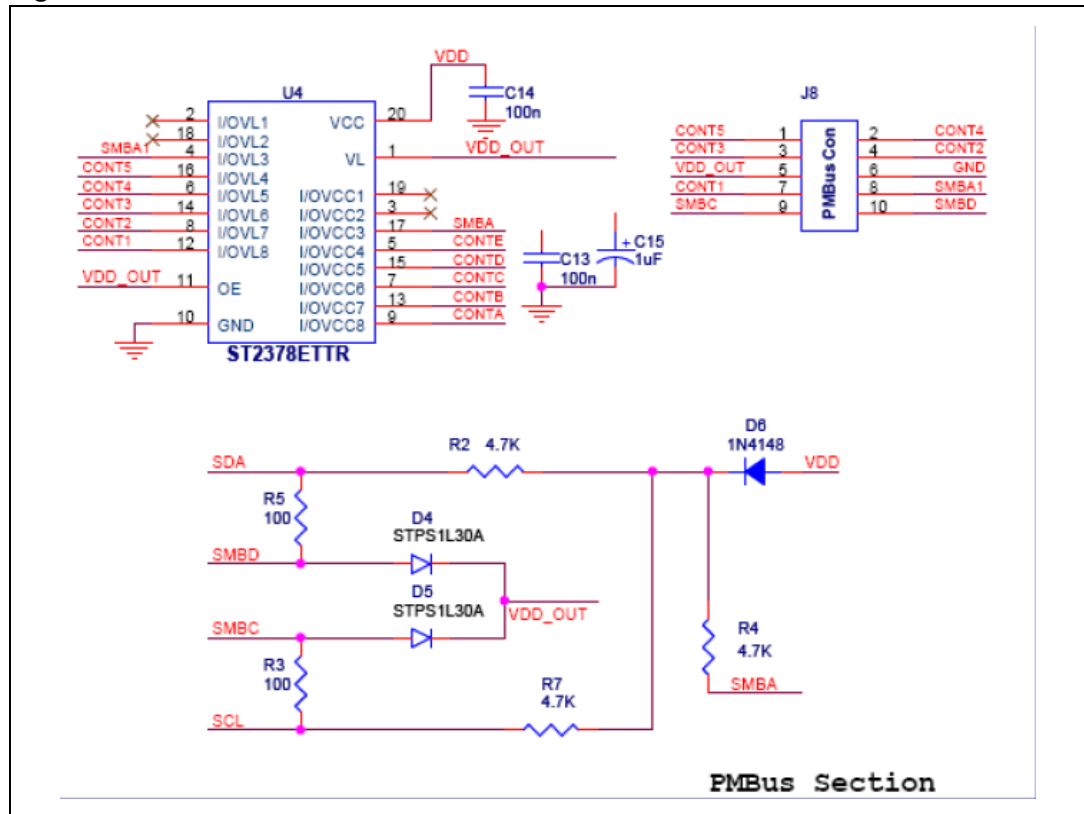

Figure 2. PMBus section



2 Revision history

Table 1. Document revision history

Date	Revision	Changes
28-Nov-2008	1	Initial release.

Please Read Carefully:

Information in this document is provided solely in connection with ST products. STMicroelectronics NV and its subsidiaries ("ST") reserve the right to make changes, corrections, modifications or improvements, to this document, and the products and services described herein at any time, without notice.

All ST products are sold pursuant to ST's terms and conditions of sale.

Purchasers are solely responsible for the choice, selection and use of the ST products and services described herein, and ST assumes no liability whatsoever relating to the choice, selection or use of the ST products and services described herein.

No license, express or implied, by estoppel or otherwise, to any intellectual property rights is granted under this document. If any part of this document refers to any third party products or services it shall not be deemed a license grant by ST for the use of such third party products or services, or any intellectual property contained therein or considered as a warranty covering the use in any manner whatsoever of such third party products or services or any intellectual property contained therein.

UNLESS OTHERWISE SET FORTH IN ST'S TERMS AND CONDITIONS OF SALE ST DISCLAIMS ANY EXPRESS OR IMPLIED WARRANTY WITH RESPECT TO THE USE AND/OR SALE OF ST PRODUCTS INCLUDING WITHOUT LIMITATION IMPLIED WARRANTIES OF MERCHANTABILITY, FITNESS FOR A PARTICULAR PURPOSE (AND THEIR EQUIVALENTS UNDER THE LAWS OF ANY JURISDICTION), OR INFRINGEMENT OF ANY PATENT, COPYRIGHT OR OTHER INTELLECTUAL PROPERTY RIGHT.

UNLESS EXPRESSLY APPROVED IN WRITING BY AN AUTHORIZED ST REPRESENTATIVE, ST PRODUCTS ARE NOT RECOMMENDED, AUTHORIZED OR WARRANTED FOR USE IN MILITARY, AIR CRAFT, SPACE, LIFE SAVING, OR LIFE SUSTAINING APPLICATIONS, NOR IN PRODUCTS OR SYSTEMS WHERE FAILURE OR MALFUNCTION MAY RESULT IN PERSONAL INJURY, DEATH, OR SEVERE PROPERTY OR ENVIRONMENTAL DAMAGE. ST PRODUCTS WHICH ARE NOT SPECIFIED AS "AUTOMOTIVE GRADE" MAY ONLY BE USED IN AUTOMOTIVE APPLICATIONS AT USER'S OWN RISK.

Resale of ST products with provisions different from the statements and/or technical features set forth in this document shall immediately void any warranty granted by ST for the ST product or service described herein and shall not create or extend in any manner whatsoever, any liability of ST.

ST and the ST logo are trademarks or registered trademarks of ST in various countries.

Information in this document supersedes and replaces all information previously supplied.

The ST logo is a registered trademark of STMicroelectronics. All other names are the property of their respective owners.

© 2008 STMicroelectronics - All rights reserved

STMicroelectronics group of companies

Australia - Belgium - Brazil - Canada - China - Czech Republic - Finland - France - Germany - Hong Kong - India - Israel - Italy - Japan - Malaysia - Malta - Morocco - Singapore - Spain - Sweden - Switzerland - United Kingdom - United States of America

www.st.com

