

ST802RT1B Ethernet PHY demonstration board

Data brief

Features

- ST802RT1B fast Ethernet physical layer transceiver
- On-board 3.3 V LDO regulator
- On-board 25 MHz crystal
- 12 jumpers for boot-strap configuration (MII address, auto-negotiation, loopback, power down, MII/RMII configuration)
- GND test points and jumpers for power consumption measurement
- Connectors:
 - 20-pin full pitch header connector for debugging (compatible with STM32F107 controller board)
 - 40-pin connector compatible with the Spirent Communications SmartBits 200/2000 (SMB-200/ SMB-2000) analysis system
 - Optical transceiver connector
- RoHS compliant

Description

The STEVAL-PCC011V1 demonstration board is designed as an evaluation platform for the ST802RT1B, Fast Ethernet physical layer (PHY) interface supporting 100BASE-FX applications. The PHY provides a media independent interface (MII) and reduced media independent interface (RMII) for easy attachment to 10/100 media access controllers (MAC).

Many jumpers, test points and connectors on the demonstration board allow testing of the features provided by the ST802RT1B Ethernet PHY.

An additional header connector allows connection to the STM32F107 controller demonstration board (not included with the STEVAL-PCC011V1), providing the capability for quick evaluation of the complete application – microcontroller and the physical layer.

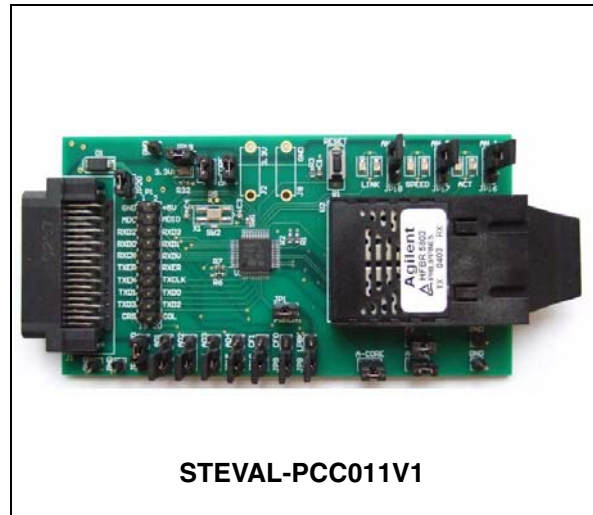

The controller board is pre-Flashed with a web server demonstration.

The STM32F107 controller demonstration board is available separately through order code STEVAL-PCC010V1.

1 Schematic diagrams

Figure 1. ST802RT1 FX mode Ethernet PHY demonstration board schematic - part 1

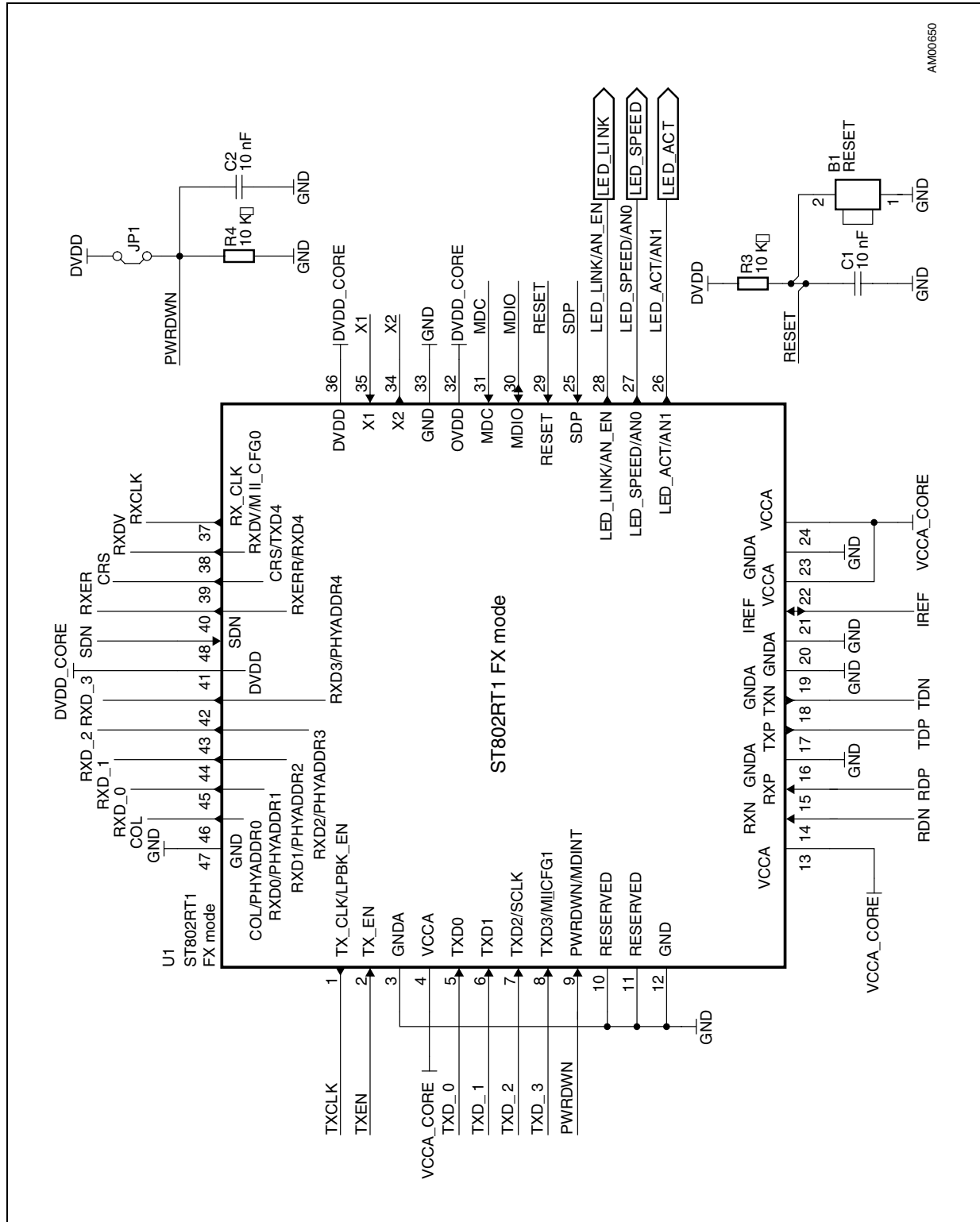
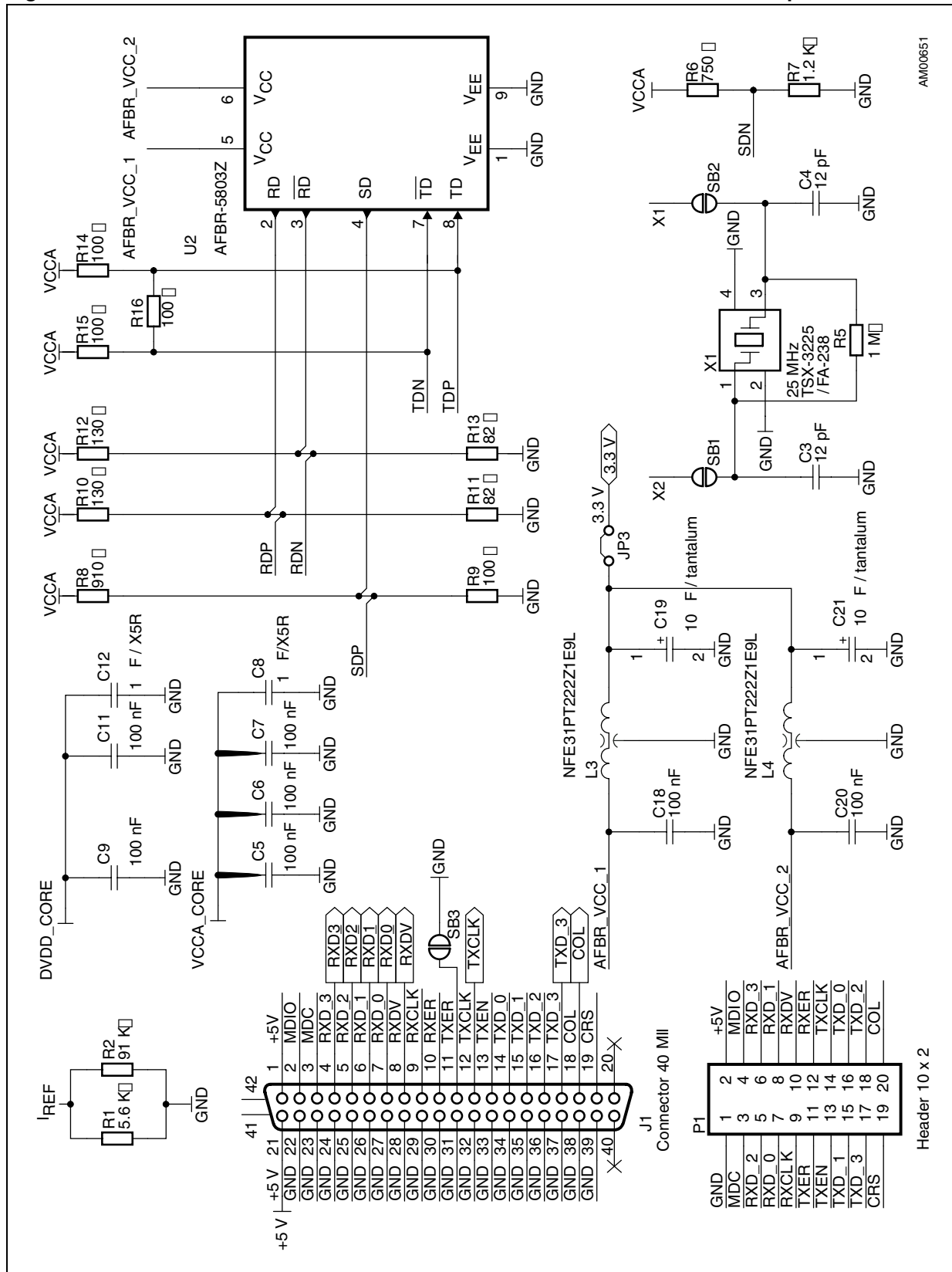
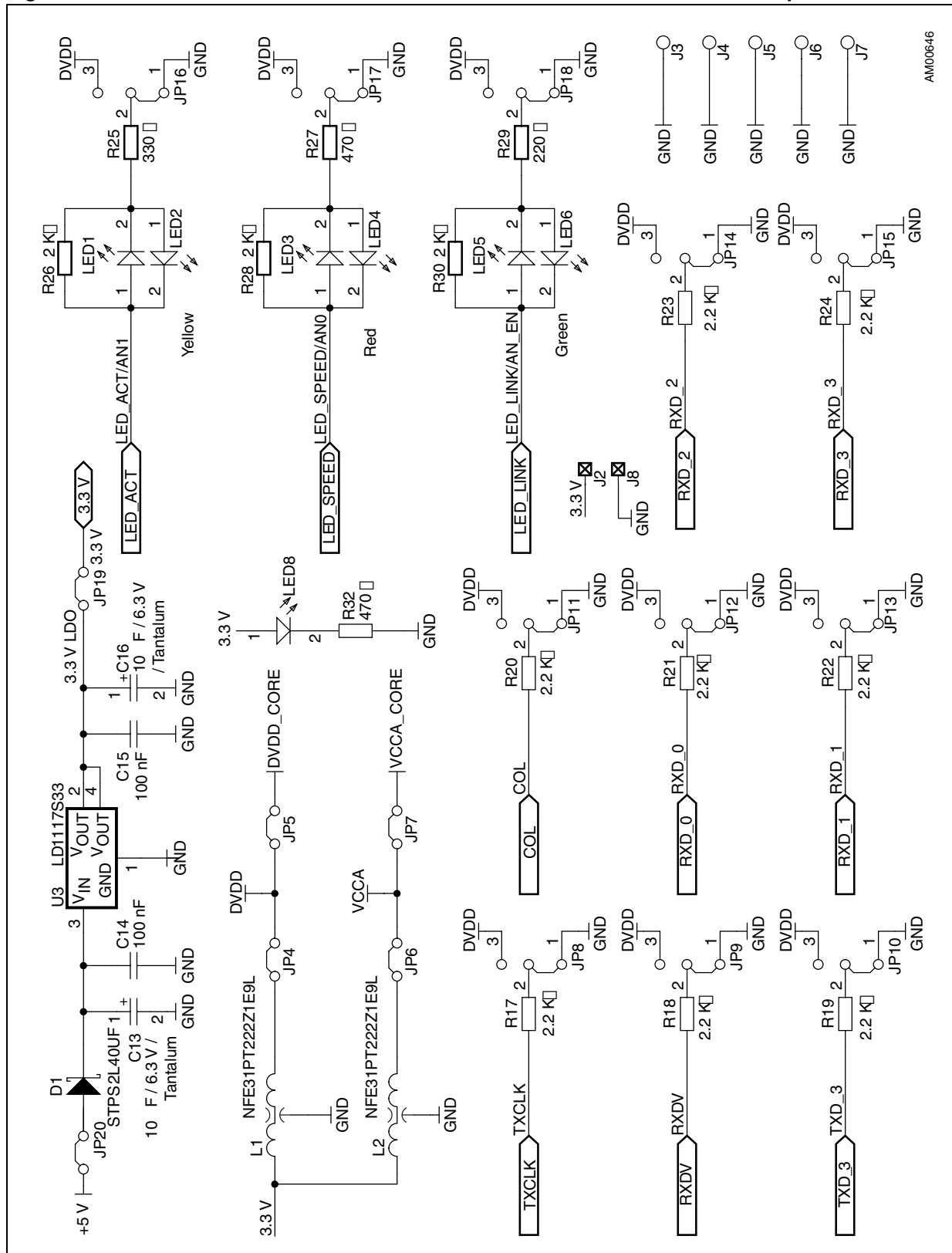

Figure 2. ST802RT1 FX mode Ethernet PHY demonstration board schematic - part 2



AM00651

Figure 3. ST802RT1 FX mode Ethernet PHY demonstration board schematic - part 3



AM00646

2 Revision history

Table 1. Document revision history

Date	Revision	Changes
22-Feb-2010	1	Initial release.

Please Read Carefully:

Information in this document is provided solely in connection with ST products. STMicroelectronics NV and its subsidiaries ("ST") reserve the right to make changes, corrections, modifications or improvements, to this document, and the products and services described herein at any time, without notice.

All ST products are sold pursuant to ST's terms and conditions of sale.

Purchasers are solely responsible for the choice, selection and use of the ST products and services described herein, and ST assumes no liability whatsoever relating to the choice, selection or use of the ST products and services described herein.

No license, express or implied, by estoppel or otherwise, to any intellectual property rights is granted under this document. If any part of this document refers to any third party products or services it shall not be deemed a license grant by ST for the use of such third party products or services, or any intellectual property contained therein or considered as a warranty covering the use in any manner whatsoever of such third party products or services or any intellectual property contained therein.

UNLESS OTHERWISE SET FORTH IN ST'S TERMS AND CONDITIONS OF SALE ST DISCLAIMS ANY EXPRESS OR IMPLIED WARRANTY WITH RESPECT TO THE USE AND/OR SALE OF ST PRODUCTS INCLUDING WITHOUT LIMITATION IMPLIED WARRANTIES OF MERCHANTABILITY, FITNESS FOR A PARTICULAR PURPOSE (AND THEIR EQUIVALENTS UNDER THE LAWS OF ANY JURISDICTION), OR INFRINGEMENT OF ANY PATENT, COPYRIGHT OR OTHER INTELLECTUAL PROPERTY RIGHT.

UNLESS EXPRESSLY APPROVED IN WRITING BY AN AUTHORIZED ST REPRESENTATIVE, ST PRODUCTS ARE NOT RECOMMENDED, AUTHORIZED OR WARRANTED FOR USE IN MILITARY, AIR CRAFT, SPACE, LIFE SAVING, OR LIFE SUSTAINING APPLICATIONS, NOR IN PRODUCTS OR SYSTEMS WHERE FAILURE OR MALFUNCTION MAY RESULT IN PERSONAL INJURY, DEATH, OR SEVERE PROPERTY OR ENVIRONMENTAL DAMAGE. ST PRODUCTS WHICH ARE NOT SPECIFIED AS "AUTOMOTIVE GRADE" MAY ONLY BE USED IN AUTOMOTIVE APPLICATIONS AT USER'S OWN RISK.

Resale of ST products with provisions different from the statements and/or technical features set forth in this document shall immediately void any warranty granted by ST for the ST product or service described herein and shall not create or extend in any manner whatsoever, any liability of ST.

ST and the ST logo are trademarks or registered trademarks of ST in various countries.

Information in this document supersedes and replaces all information previously supplied.

The ST logo is a registered trademark of STMicroelectronics. All other names are the property of their respective owners.

© 2010 STMicroelectronics - All rights reserved

STMicroelectronics group of companies

Australia - Belgium - Brazil - Canada - China - Czech Republic - Finland - France - Germany - Hong Kong - India - Israel - Italy - Japan - Malaysia - Malta - Morocco - Philippines - Singapore - Spain - Sweden - Switzerland - United Kingdom - United States of America

www.st.com