



# STEVAL-PCC012V1

## Connectivity gateway demonstration board based on the STM32F107

Data brief

### Features

- Offers Ethernet, USB OTG and general-purpose extension connector
- Two positions for optional Wi-Fi modules
- A microSD™ card socket
- Digital/analog extension connectors compatible with STEVAL-MKI0xxV1 MEMS extension boards and STEVAL-CCA021V1 audio extension board
- Compatible with ST7590 “PRIME” board – narrow-band OFDM
- JTAG interface for microcontroller firmware change/update
- DC-DC power supply using the L7986A
- Stand-alone demonstration firmware, on-board LEDs and joystick
- RoHS compliant



### Description

The STEVAL-PCC012V1 demonstration board is equipped with an Ethernet interface, four digital/analog extension connectors (I<sup>2</sup>C, SPI, etc.), footprint positions for two different Wi-Fi modules, an OFDM PRIME power line networking extension connector and a microSD card socket with SPI interface. It also features a 5-way joystick, four general-purpose LEDs and two LEDs dedicated to the user interface.

The demonstration board also includes digital/analog input/output connectors with pinouts compatible with other demonstration boards from STMicroelectronics.

The STEVAL-PCC012V1 can be supplied from a standard DC power supply (7 - 35 VDC), or directly using a 24 VDC industrial mains supply.

# 1 Schematic diagram

Figure 1. Power supply

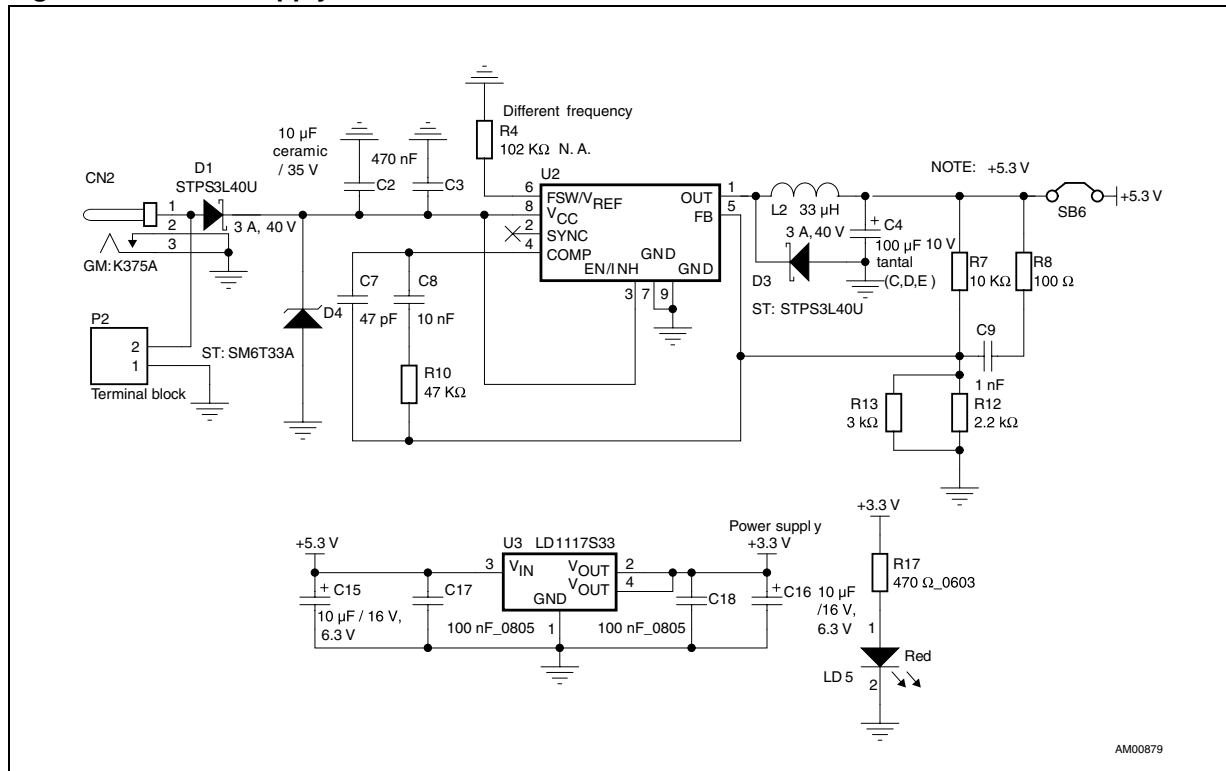


Figure 2. STM32 - part 1 (inputs, outputs, clock, reset)

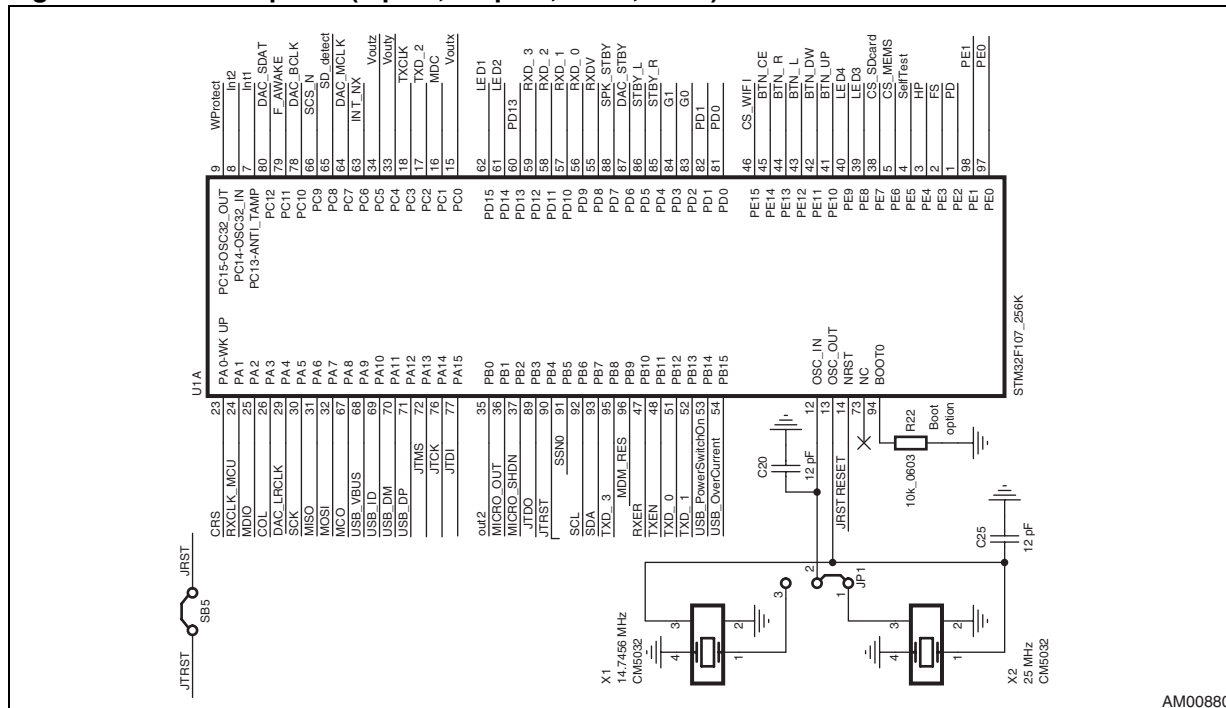


Figure 3. STM32 - part 2 (JTAG, LEDs, audio extension connector)

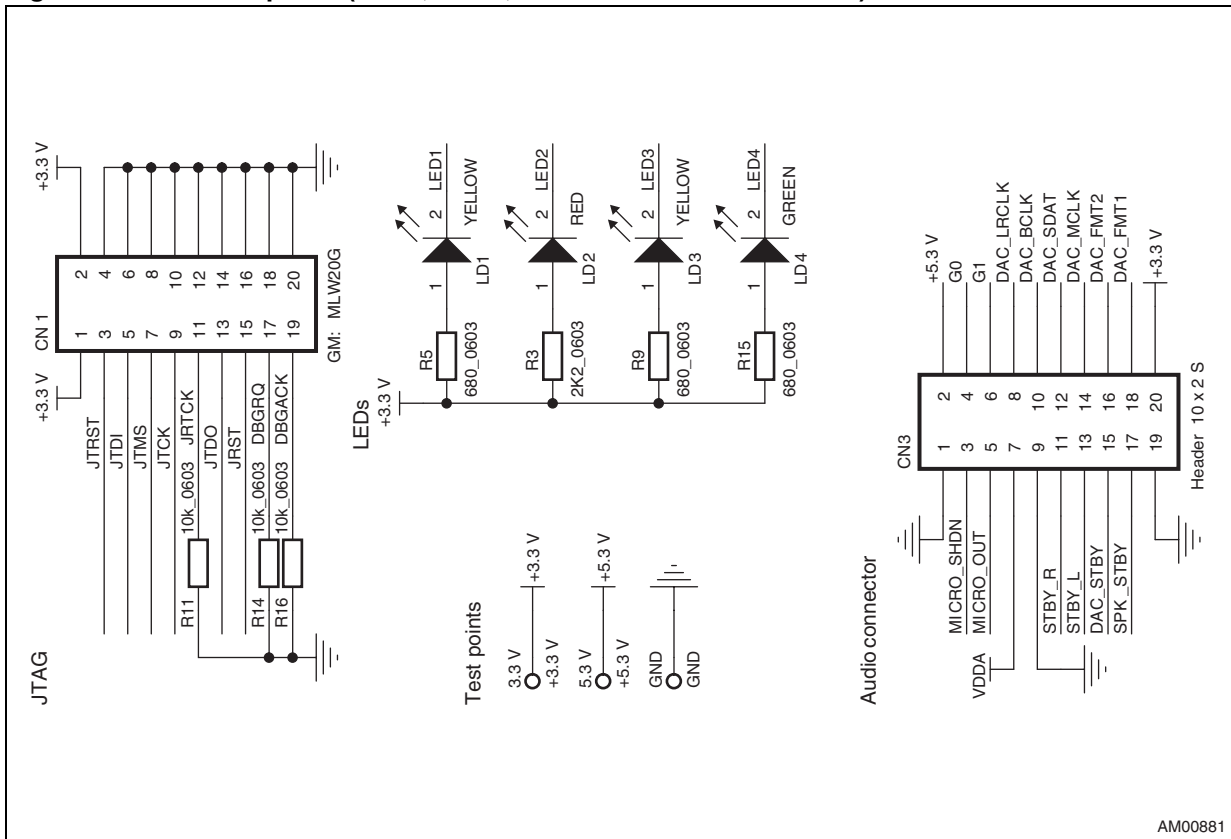


Figure 4. STM32 - part 3 (joystick, analog decoupling, DAC\_FMT signals)

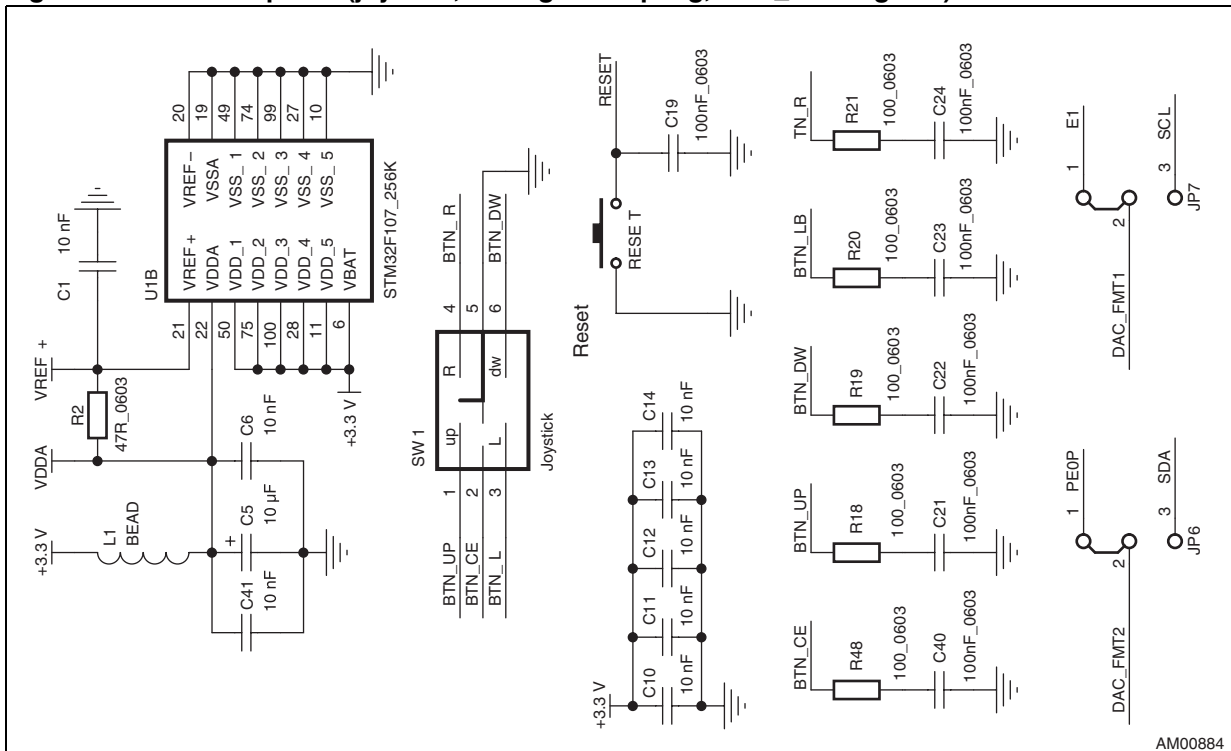
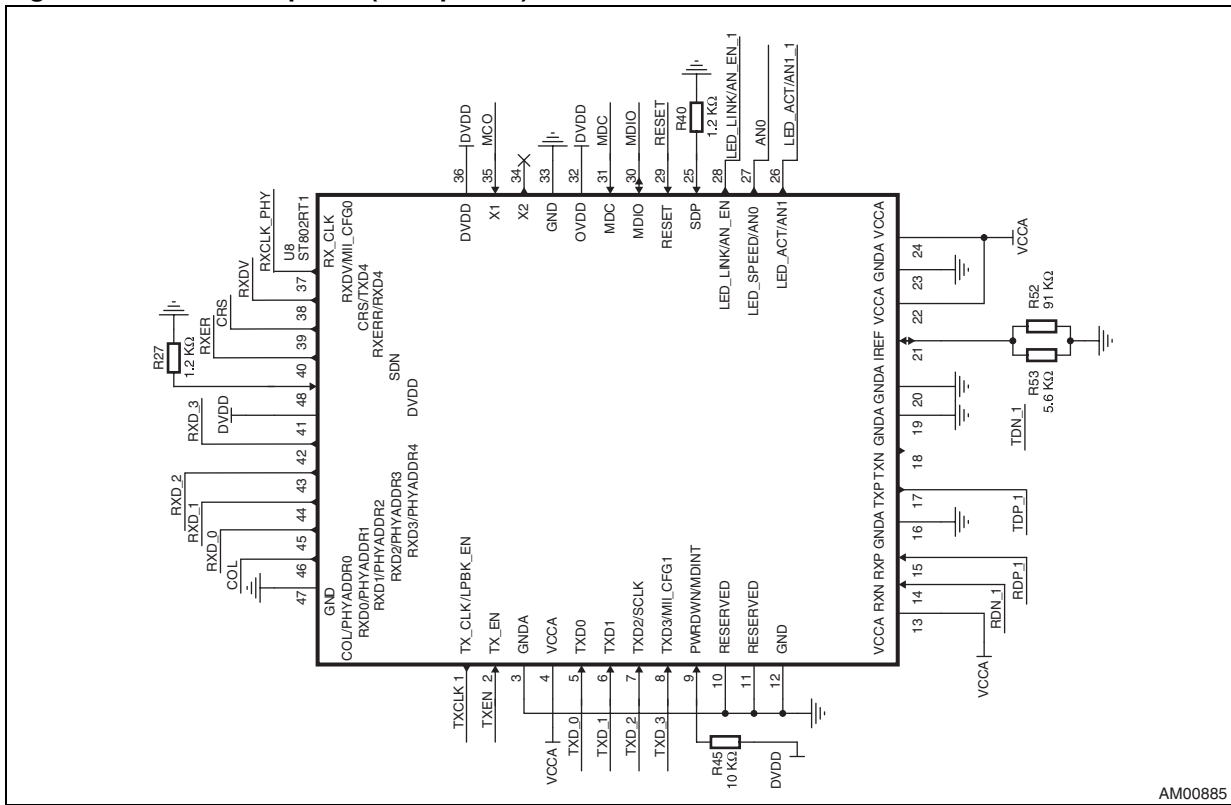
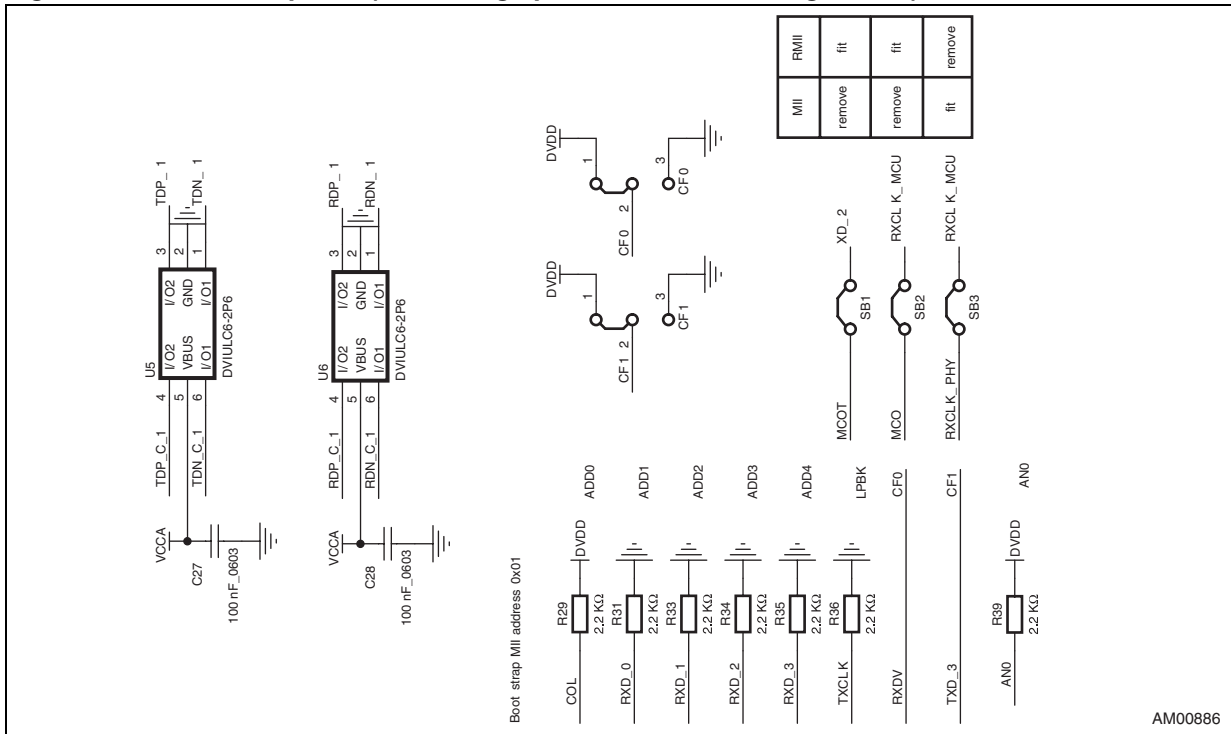


Figure 5. Ethernet - part 1 (PHY pinout)



AM00885

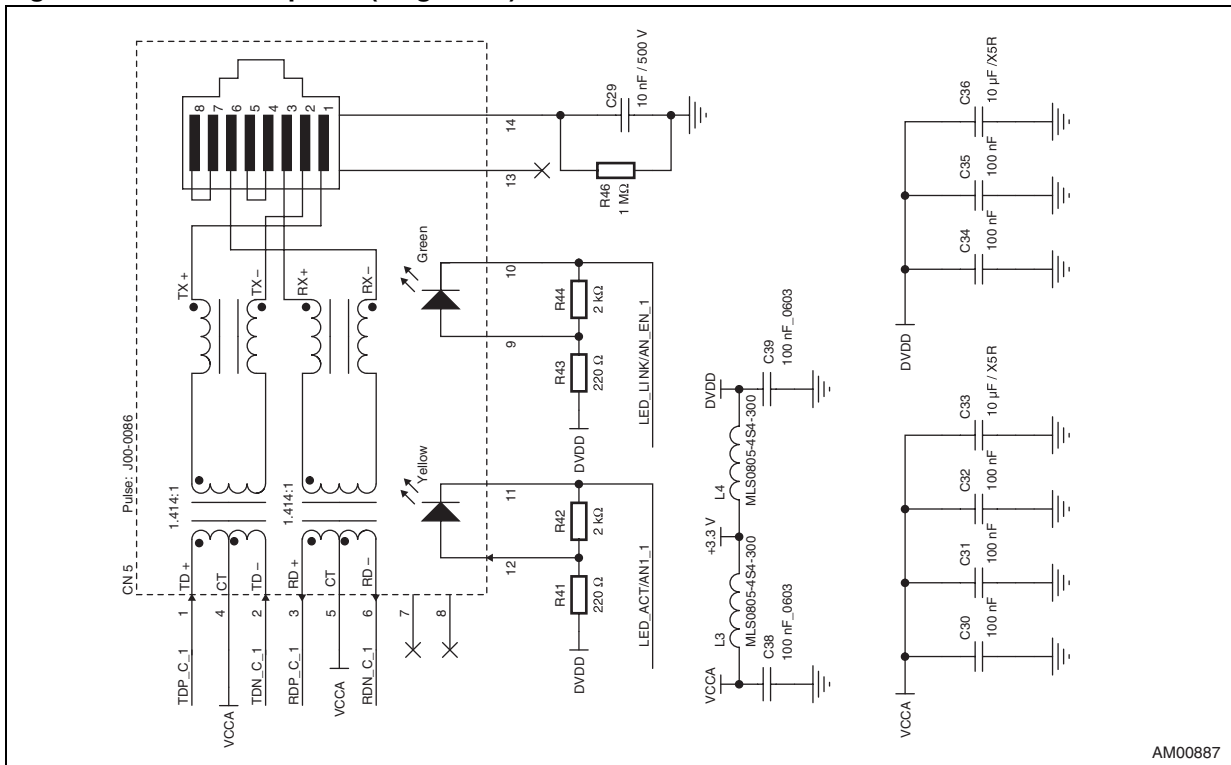
Figure 6. Ethernet - part 2 (overvoltage protection, PHY configuration)



AM00886

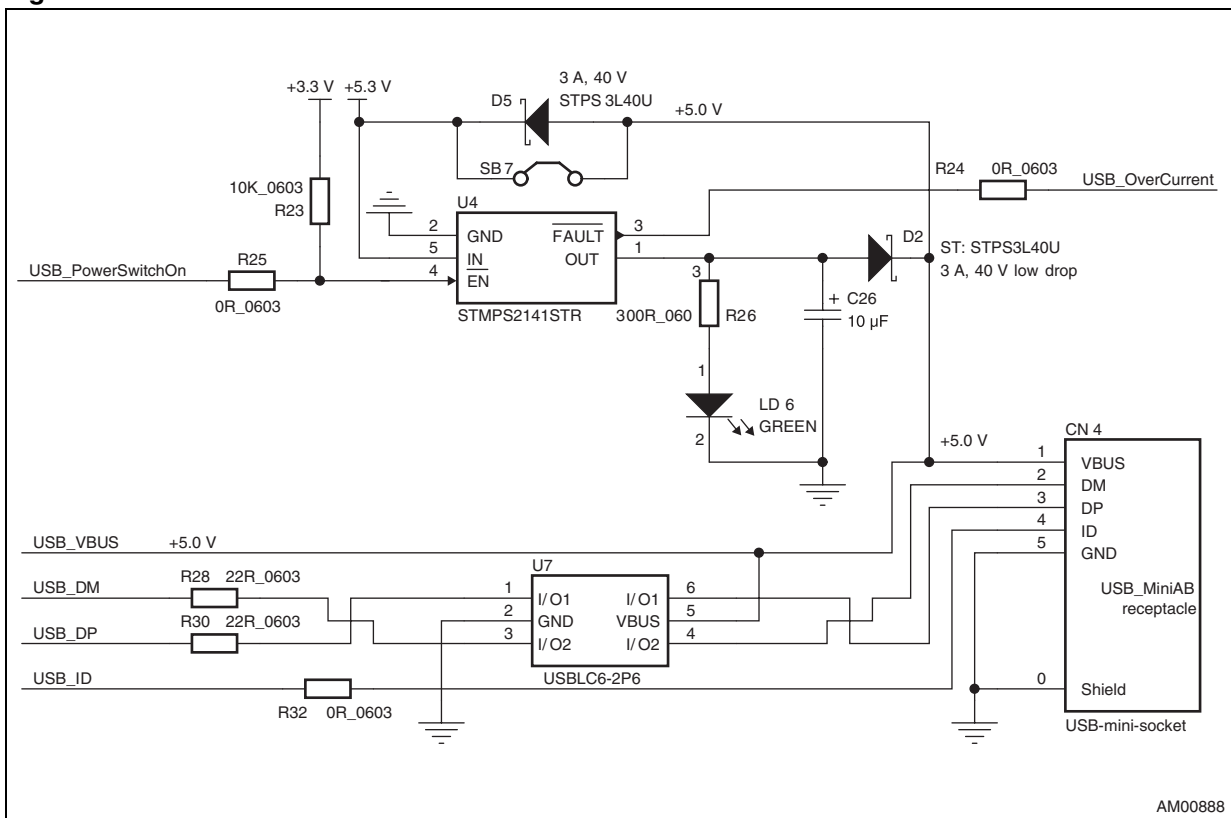


Figure 7. Ethernet - part 3 (magnetics)



AM00887

Figure 8. USB-OTG



AM00888

Figure 9. Wi-Fi module-1

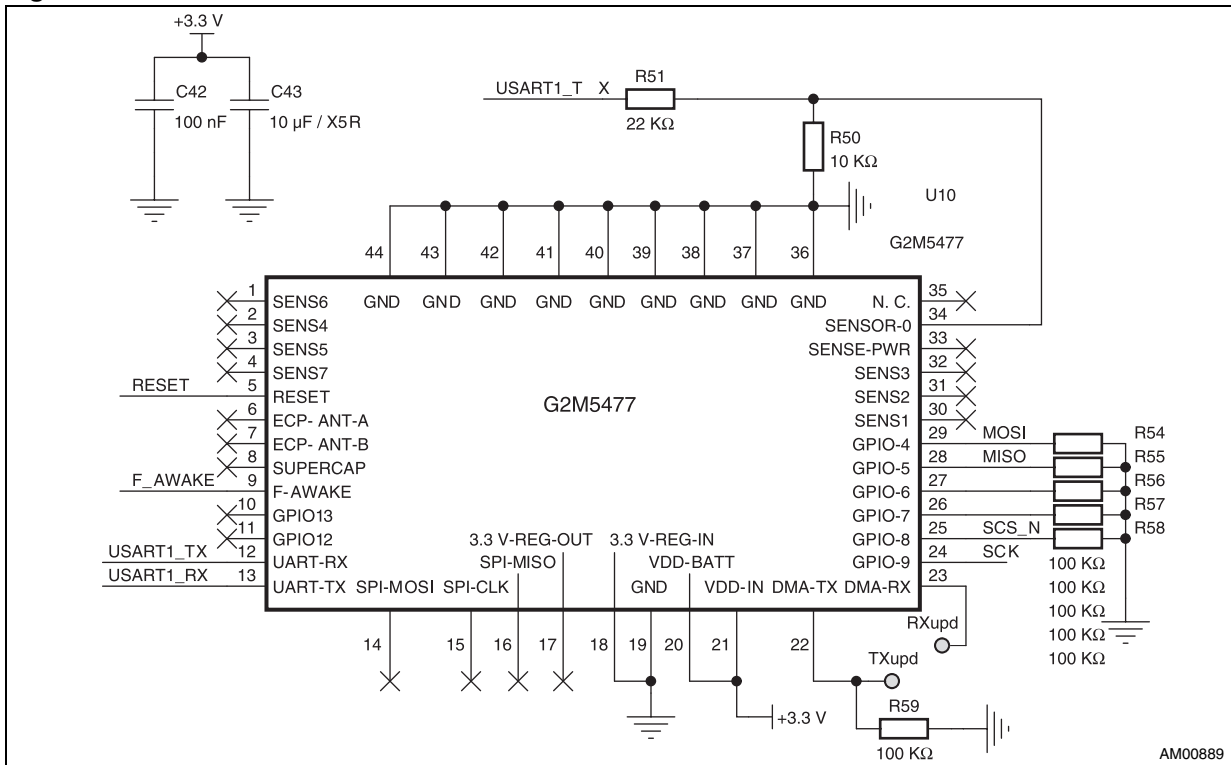


Figure 10. Wi-Fi module-2

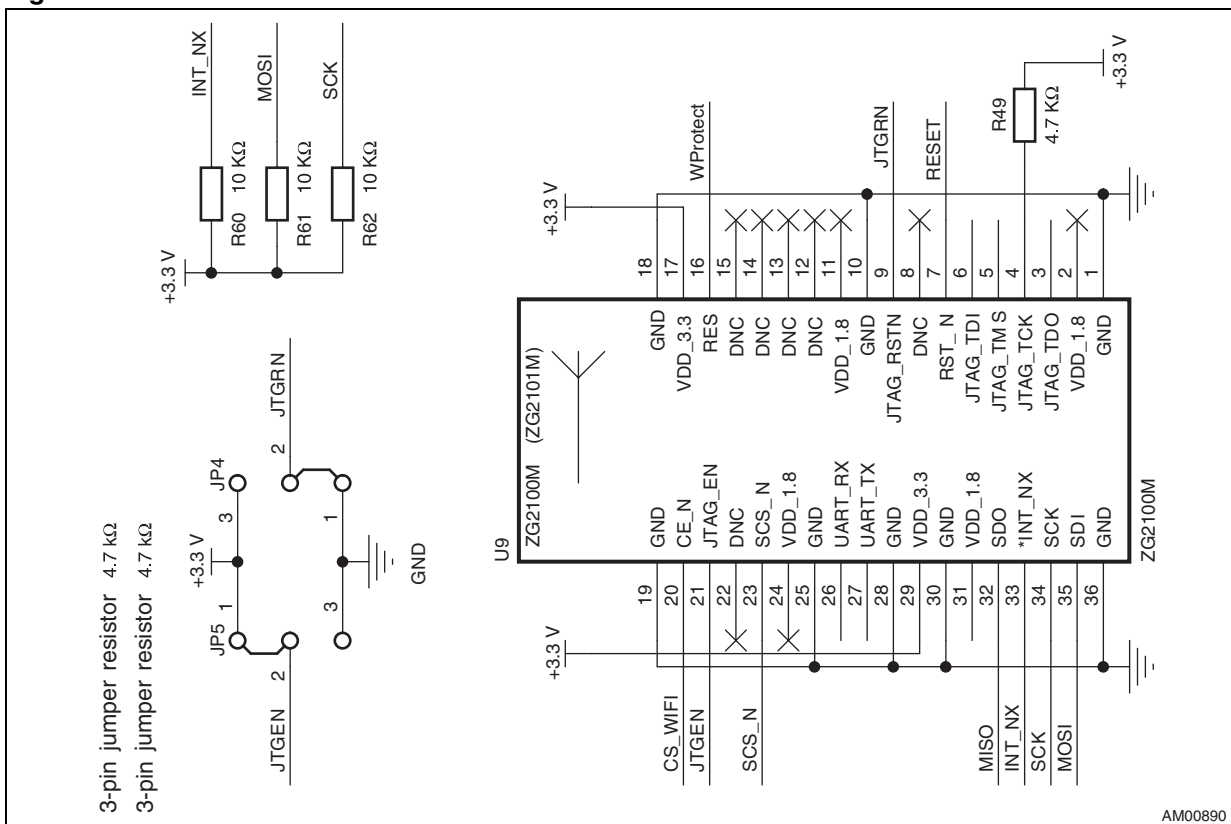


Figure 11. MicroSD card

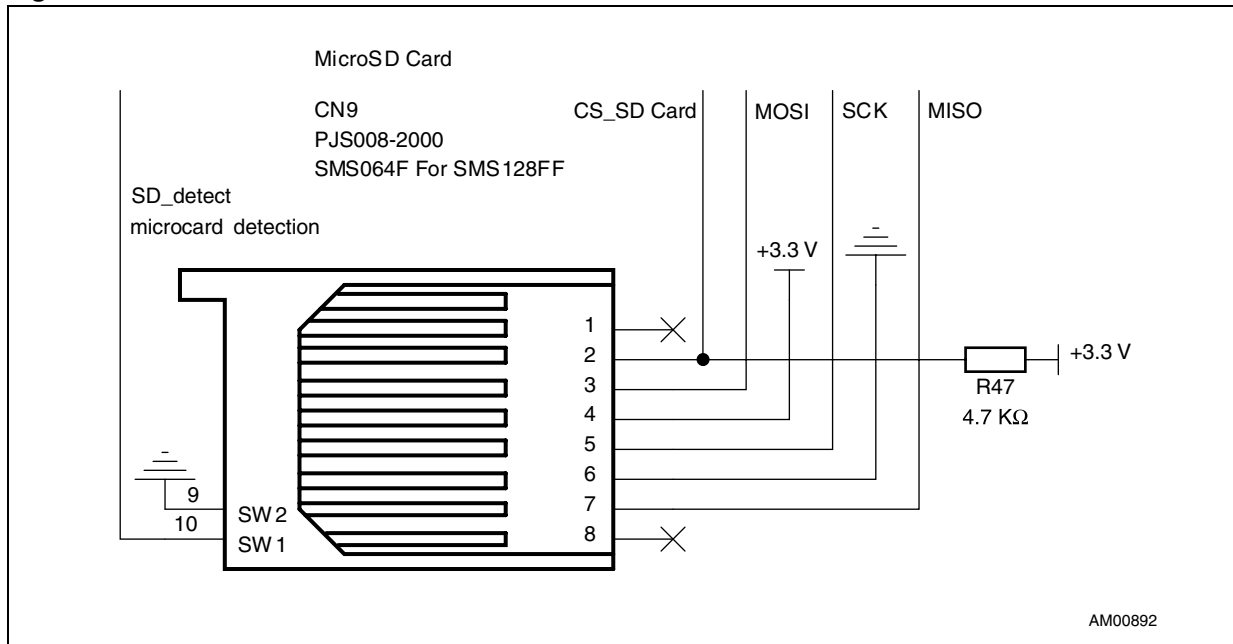
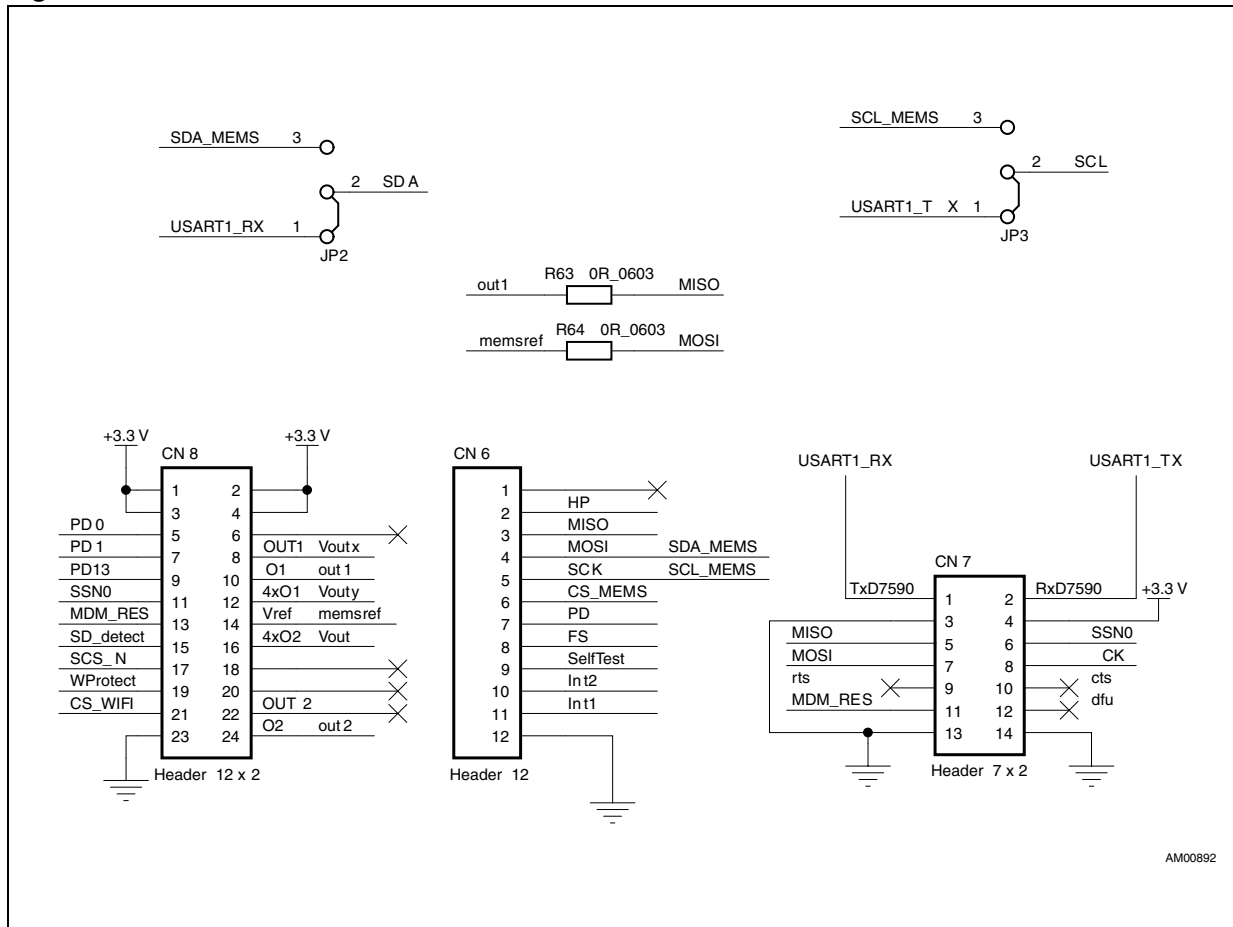
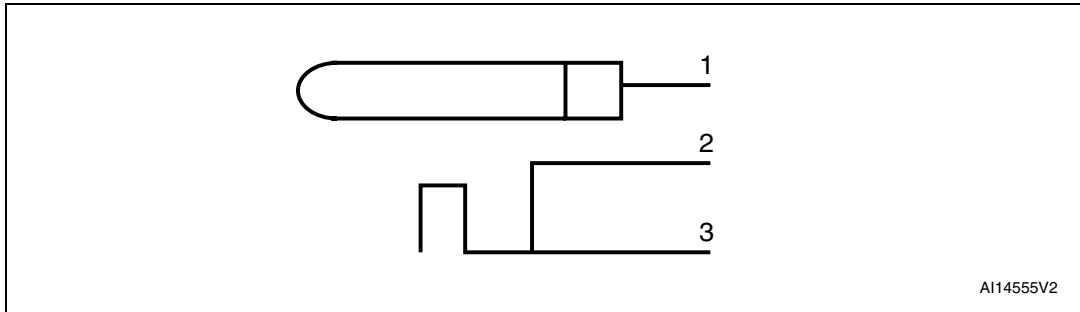


Figure 12. MEMS extension connectors



## 2 Power supply connectors CN2, P2

Figure 13. Power supply connector CN2

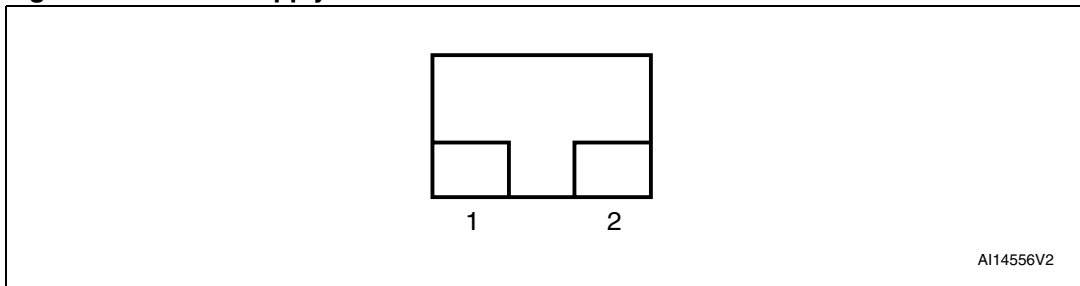


AI14555V2

Table 1. Power supply connector CN2

Pin	Signal	Pin	Signal
1	24 VDC	3	GND
2	GND		

Figure 14. Power supply connector P2



AI14556V2

Table 2. Power supply connector P2

Pin	Signal
1	24 VDC
2	GND



### 3 Revision history

**Table 3. Document revision history**

Date	Revision	Changes
15-Jun-2010	1	Initial release.

**Please Read Carefully:**

Information in this document is provided solely in connection with ST products. STMicroelectronics NV and its subsidiaries ("ST") reserve the right to make changes, corrections, modifications or improvements, to this document, and the products and services described herein at any time, without notice.

All ST products are sold pursuant to ST's terms and conditions of sale.

Purchasers are solely responsible for the choice, selection and use of the ST products and services described herein, and ST assumes no liability whatsoever relating to the choice, selection or use of the ST products and services described herein.

No license, express or implied, by estoppel or otherwise, to any intellectual property rights is granted under this document. If any part of this document refers to any third party products or services it shall not be deemed a license grant by ST for the use of such third party products or services, or any intellectual property contained therein or considered as a warranty covering the use in any manner whatsoever of such third party products or services or any intellectual property contained therein.

**UNLESS OTHERWISE SET FORTH IN ST'S TERMS AND CONDITIONS OF SALE ST DISCLAIMS ANY EXPRESS OR IMPLIED WARRANTY WITH RESPECT TO THE USE AND/OR SALE OF ST PRODUCTS INCLUDING WITHOUT LIMITATION IMPLIED WARRANTIES OF MERCHANTABILITY, FITNESS FOR A PARTICULAR PURPOSE (AND THEIR EQUIVALENTS UNDER THE LAWS OF ANY JURISDICTION), OR INFRINGEMENT OF ANY PATENT, COPYRIGHT OR OTHER INTELLECTUAL PROPERTY RIGHT.**

**UNLESS EXPRESSLY APPROVED IN WRITING BY AN AUTHORIZED ST REPRESENTATIVE, ST PRODUCTS ARE NOT RECOMMENDED, AUTHORIZED OR WARRANTED FOR USE IN MILITARY, AIR CRAFT, SPACE, LIFE SAVING, OR LIFE SUSTAINING APPLICATIONS, NOR IN PRODUCTS OR SYSTEMS WHERE FAILURE OR MALFUNCTION MAY RESULT IN PERSONAL INJURY, DEATH, OR SEVERE PROPERTY OR ENVIRONMENTAL DAMAGE. ST PRODUCTS WHICH ARE NOT SPECIFIED AS "AUTOMOTIVE GRADE" MAY ONLY BE USED IN AUTOMOTIVE APPLICATIONS AT USER'S OWN RISK.**

Resale of ST products with provisions different from the statements and/or technical features set forth in this document shall immediately void any warranty granted by ST for the ST product or service described herein and shall not create or extend in any manner whatsoever, any liability of ST.

ST and the ST logo are trademarks or registered trademarks of ST in various countries.

Information in this document supersedes and replaces all information previously supplied.

The ST logo is a registered trademark of STMicroelectronics. All other names are the property of their respective owners.

© 2010 STMicroelectronics - All rights reserved

STMicroelectronics group of companies

Australia - Belgium - Brazil - Canada - China - Czech Republic - Finland - France - Germany - Hong Kong - India - Israel - Italy - Japan - Malaysia - Malta - Morocco - Philippines - Singapore - Spain - Sweden - Switzerland - United Kingdom - United States of America

[www.st.com](http://www.st.com)