

From the sun to the grid through
efficient and smart semiconductors

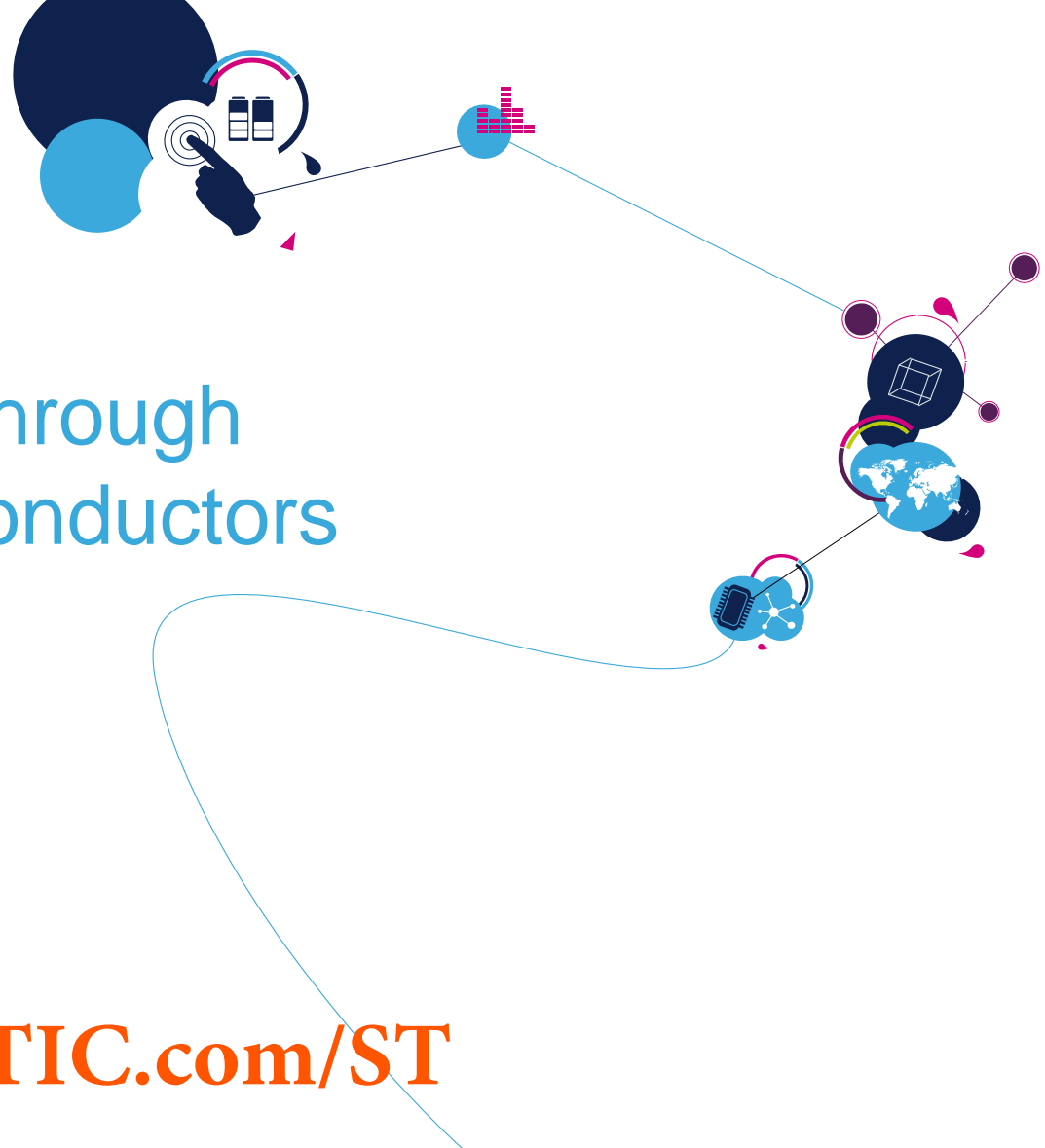

life.augmented

www.BDTIC.com/ST



Semiconductors enable the game-changing in solar applications

“.....Semiconductors can help slow down the “unstoppable force” by reducing the amount of power used by products and making the generation and distribution of electrical energy more efficient. Semiconductors also enable technologies like smart metering and smart grids that help change the energy consumption patterns of consumers. Our industry can also have a profound effect on the “immovable object” by using our expertise in silicon technology, electronic circuitry and system architecture to make **renewable energy sources** more efficient and attractive to consumers.”

ST's positioning in the photovoltaic world

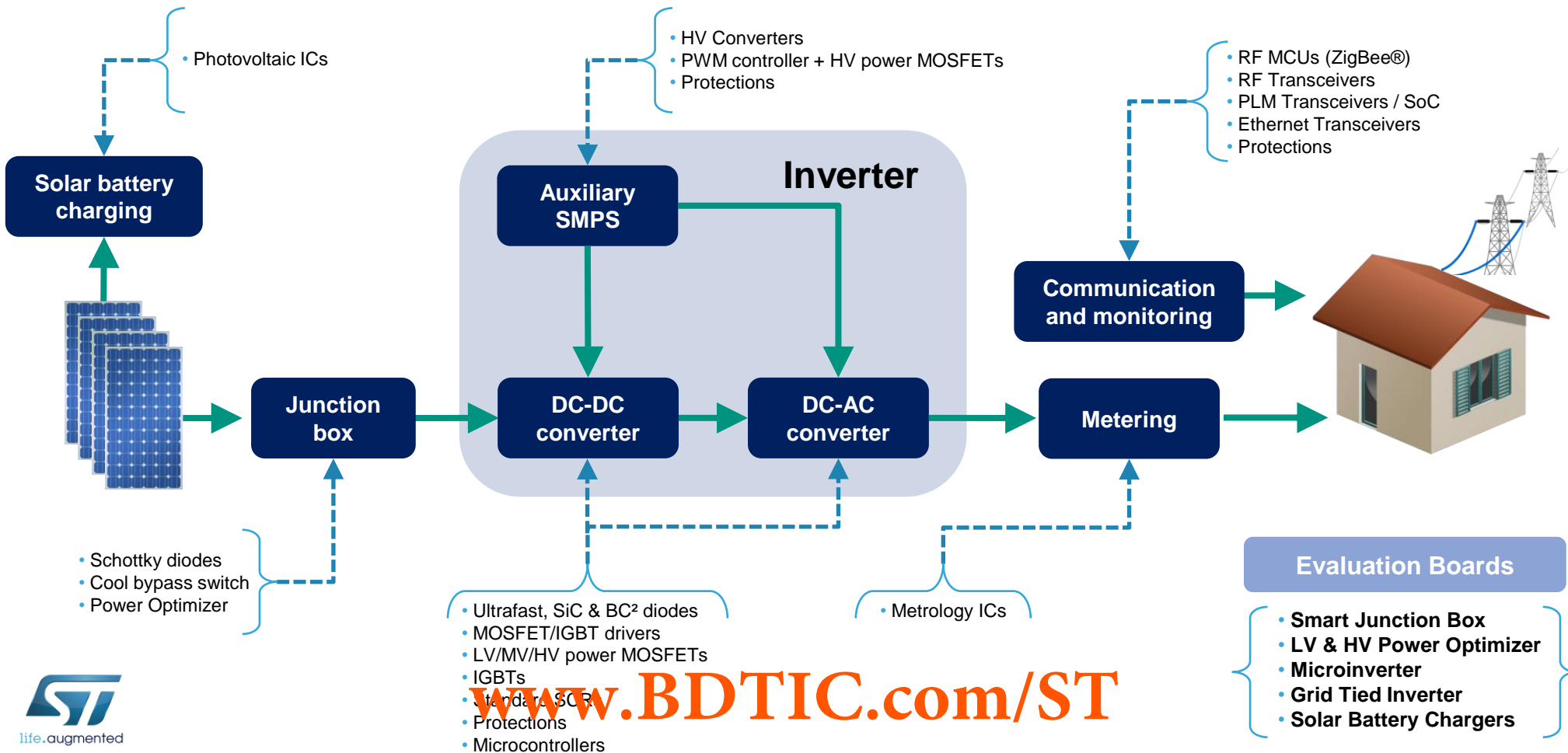

ST products for junction box

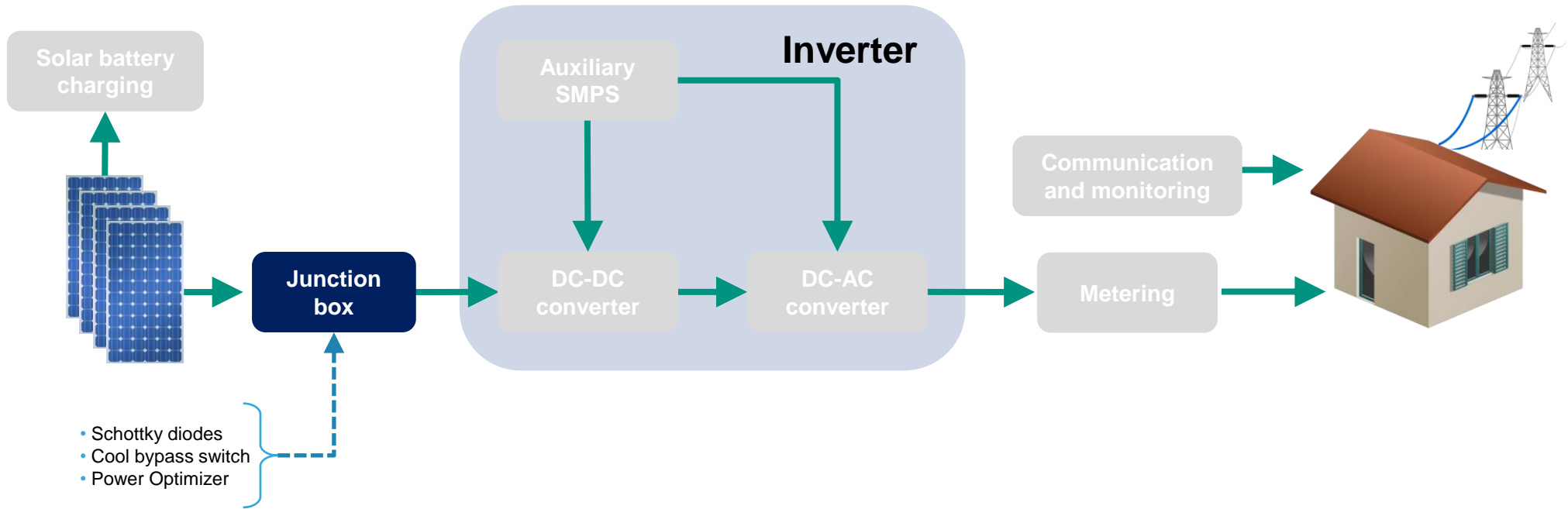

Junction box: Schottky diodes

Key features

- Low reverse current
- Low forward voltage
- Low-profile packages
- Halogen free packages

Main benefits

- Increased panel efficiency
- Increased power density
- Environmental care

D²PAK

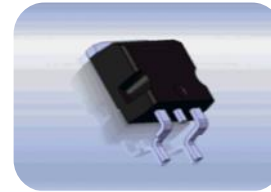

STPS1545CG-TR
STPS2045CG-TR
STPS2545CG-TR
STPS3045CG-TR
STPS5045SG-TR

DKPAK

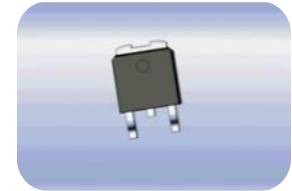

STPS1045B-TR
STPS15L45CB-TR

PowerFLAT™
5x6

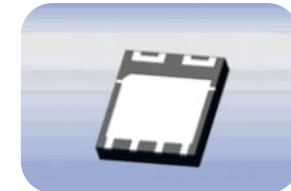

STPS15L30CDJF-TR
STPS3045DJF-TR

Bare die

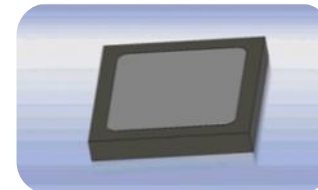

Junction box: SPV100x cool bypass switch

Key features

- System in package
- Embedded power MOSFET
- Very low forward-voltage drop
- Very low reverse leakage current

Main benefits

- Cooler than standard bypass diodes
- Low power dissipation
- Longer lifetime
- Higher reliability

TO-220



SPV1001T40
SPV1002T40

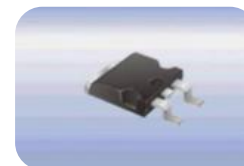

D²PAK

SPV1001D40
SPV1002D40

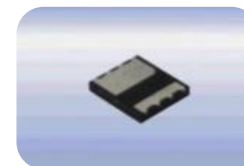

PQFN 5x6

SPV1001N40
SPV1001N30

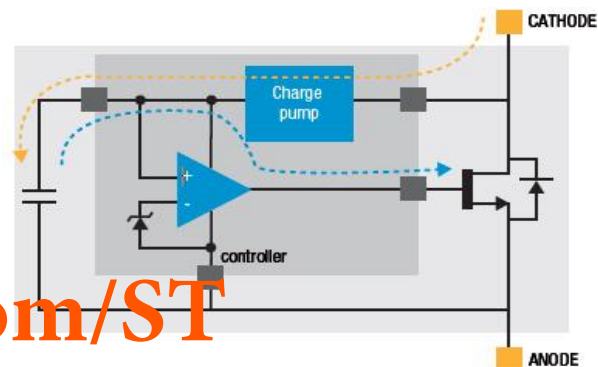

Junction box: SPV1020 solar energy booster 7

SPV1020 distributes MPPT at panel level, boosting photovoltaic power conversion efficiency

Key features

- Monolithic DC-DC converter embedded in the panel
- Interleaved boost converter
- Built-in MPPT algorithm
- BCD8 0.18 μm technology

PowerSSO-36



SPV1020

Main benefits

- Minimized shadowing impact on power generation
- Minimized panel mismatch
- Improved inverter efficiency
- Panel diagnosis using remote monitoring and control functions

www.BDTIC.com/ST

Standard photovoltaic panel

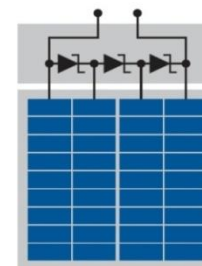

Solar energy booster

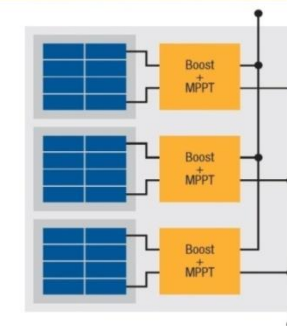

ST products for DC-DC and DC-AC converter

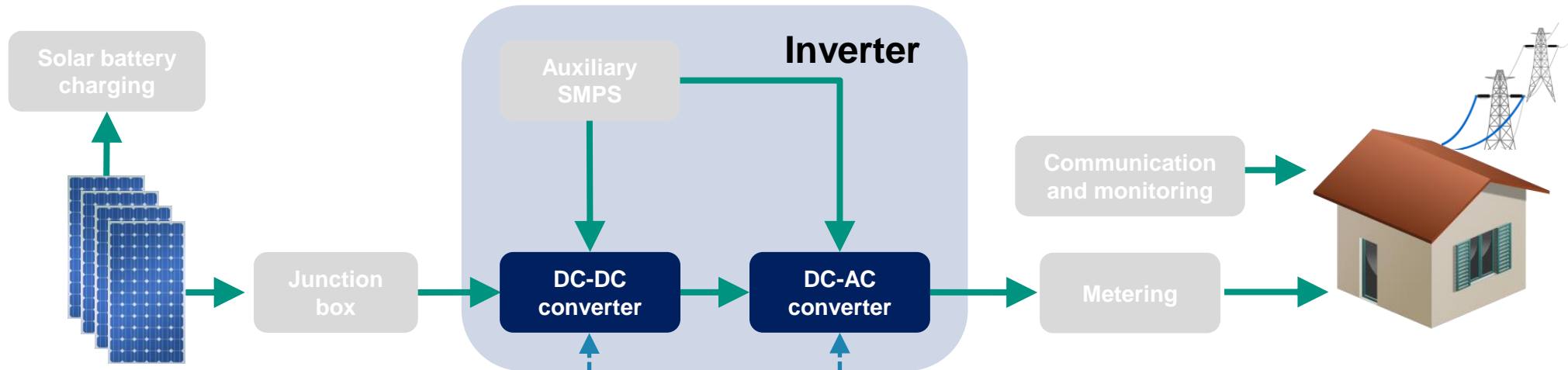

- Ultrafast, SiC & BC² diodes
- MOSFET/IGBT drivers
- LV/MV/HV power MOSFETs
- IGBTs
- Standard SCR
- Protections
- Microcontrollers

www.BDTIC.com/ST



DC-DC/DC-AC: STTH 600V ultrafast diodes

Key features

- Ultrafast switching
- Low reverse current
- Low thermal resistance
- Reduced switching and conduction losses

Main benefits

- High current capability
- Suited trade-off between V_F and t_{RR} for boost converters in solar inverters

TO-220AC

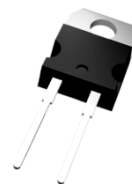

STTH15L06D

TO-247

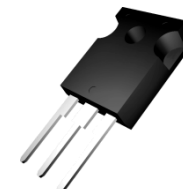

STTH60L06CW
STTH30L06CW

TO-220AC
DOP3
insulated



600V Tandem diodes G1
STTH806DTI
STTH1506DPI

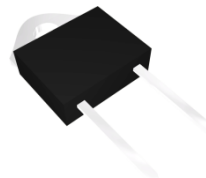

DO-247

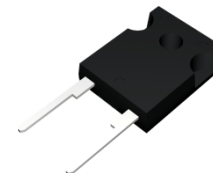

STTH6006W
STTH3006W

600V Tandem diodes G2
STTH8T06DI*
STTH12T06DI**



DC-DC/DC-AC: silicon-carbide (SiC) G1 diodes

10

STPSCxx06 series: instant switching diodes

Key features

- 600 V SiC Schottky barrier diodes
- Reliability tested under extreme conditions
- No reverse recovery charges (by construction)
- Temperature-independent switching behavior

Reverse recovery comparison

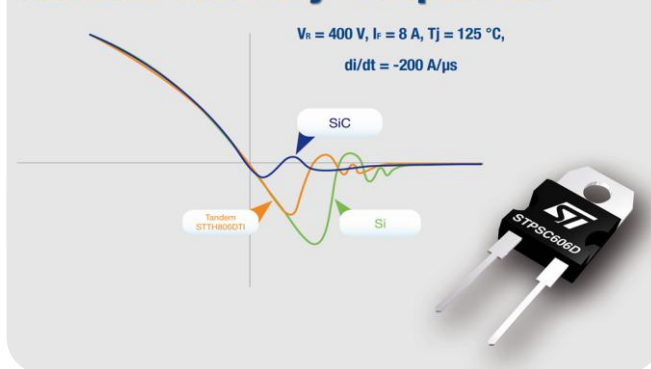

Main benefits

- Higher current density, frequency and efficiency
- Low forward voltage drop (typically 100 mV lower than competition)
- Operation certified from $-40 \text{ }^\circ\text{C}$
- Lower EMI

www.BDTIC.com/ST



DC-DC/DC-AC: silicon-carbide (SiC) G2* diodes

11

STPSCxxH065 series: instant switching diodes

Key features

- Improved merit-factor (I_{FSM}/I_0)
- V_{RRM} specified at 650V

Main benefits

- Possibility to increase the current density
- Easier design
- More safety with increased reverse voltage margin

650V SiC G2 diodes



Instant switching



Diodes

DC-DC: rectifiers for BC² topology

12

STTHxxBCxx series: new ST solution for efficiency improvement in PV systems

Key features

- Specially designed for the dedicated BC² (Back-Current Circuit) topology (ST patent)
- Suited for non insulated DC-DC converters
- High Voltage Rating

Main benefits

- Efficiency improvement on full power range (heavy & light load)
- Power-switch junction temperature reduction
- Increased power density
- BOM cost reduced

BC² up to 500 W



STTH10BC065CT

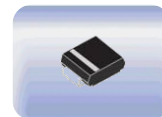

STTH3BCF060U

BC² up to 2 kW



STTH16BC065CT

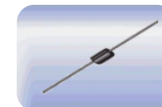

STTH5BCF060



www.BDTIC.com/ST

DC-DC/DC-AC: MOSFET / IGBT Drivers

Key features

- Integrated high-voltage half-bridge, single and multiple low-voltage gate drivers
- High current capability (up to 4A with PM8834)
- Embedded comparator for protection features (L6386E, L6390, L6391, L6393)

Main benefits

- Eliminates external high-voltage diode
- Fully protected design through smart shutdown (ST patented)
- Unique level of integration: BOM cost reduced

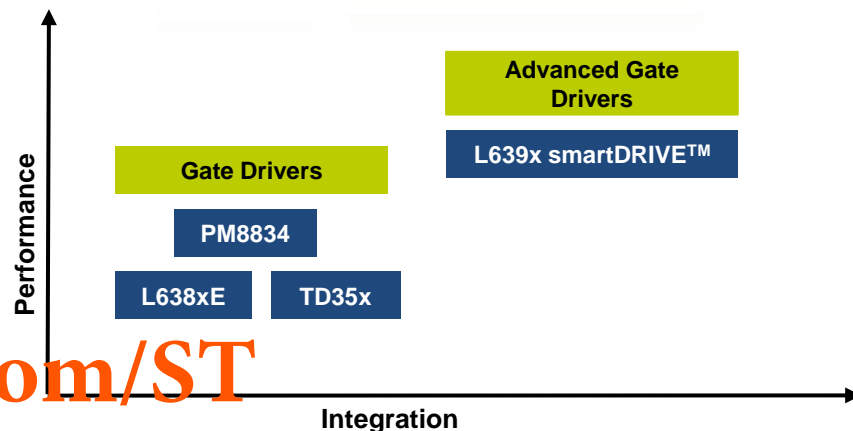
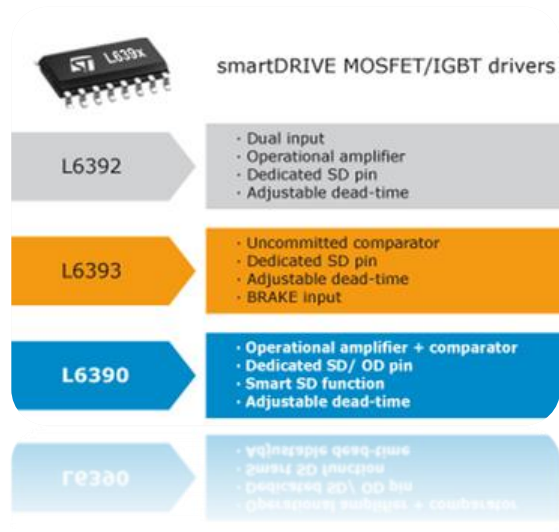

www.BDTIC.com/ST

DC-DC/DC-AC: HV Power MOSFETs – MDmesh™

Key features

- 650 V lowest $R_{DS(on)}$ x area
- Higher breakdown voltage
- Minimal intrinsic diode reverse recovery time (FDmesh™ II)
- MDmesh™ V targeted for best efficiency PV converters: **>99% in a boost topology**
- FDmesh™ II especially suitable for Bridge topologies

Main benefits

- Higher energy saving
- Increased power density
- Increased safety margin

FDmesh II
Fast Diode Series



STW54NM65ND

MDmesh V



STW88N65M5

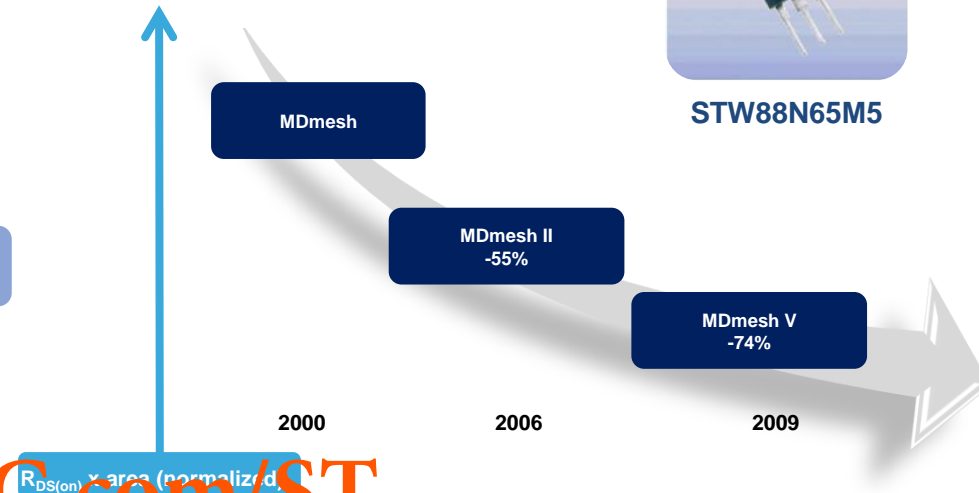

www.BDTIC.com/ST

DC-DC/DC-AC μ -inverter: LV & HV Power MOSFETs

15

Key features

- PowerFLAT 8x8 HV: 1mm thickness & 64 mm² footprint
- Low parasitic inductance
- MDmesh V 650 V lowest RDS(on) x area
- SuperMESH 5 850V lowest RDS(on) x area
- STripFET VI DeepGATE series
- RDS(on)*Qg industry benchmark



PowerFLAT™
8x8 HV

STL18N55M5
STL17N65M5 (*)
STL19N65M5 (*)
STL23NM60ND
STL23N85K5 (*)

PowerFLAT™
5x6 & 5x6 HV

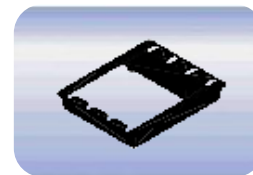

STL80N75F6
STL75N8LF6
STL18N65M5 (**)
STL15N65M5(**)

Main benefits

- Higher energy saving
- Increased power density
- Higher PCB compactness with PowerFLAT package
- Multiple sources

www.BDTIC.com/ST



DC-DC/DC-AC: 1200V SiC MOSFETs

Key features

- Industry leading R_{dson}
- Simple to drive
- Body diode with no reverse recovery charges
- High speed temperature-independent switching

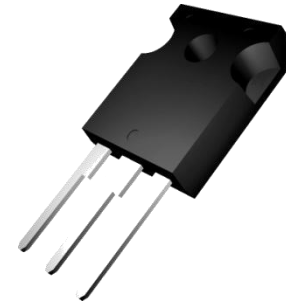

HiP247

SCT30N120 (*)

Main benefits

- Smaller form factor for lighter systems
- Save size/cost of passive components
- Higher systems efficiency
- Reduced cooling requirements (Max T_j : 200 °C)

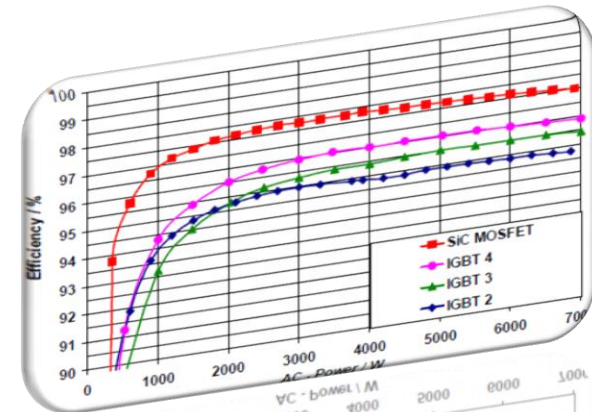

DC-DC/DC-AC: 650/1200 V IGBTs

TGFS-H series: the optimum choice for solar systems

Key features

- Using novel Field Stop IGBT Technology
- Low thermal resistance
- Low saturation voltage
- Fast switching

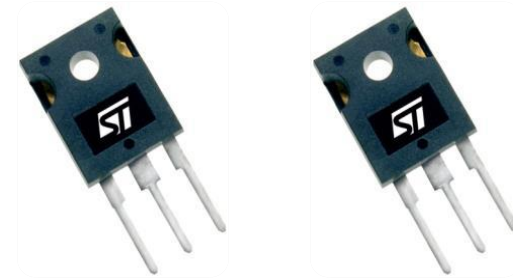

STGW60H65F, STGW50H60DF, STGW25H120DF(*) - Trench Gate Field Stop

Main benefits

- Superior conduction and switching performances
- Ideal for increasing total system efficiency

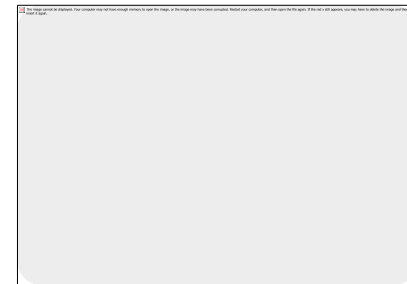

DC-AC: 600 V low frequency and ultra-fast IGBTs

S (low frequency) series

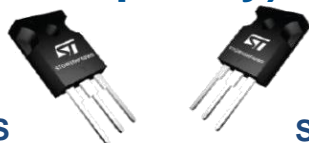

STGW50HF60S

STGW50HF60SD

Key features

- Tailored to low-frequency leg of PV inverter mixed-frequency topologies
- Ideal for applications with $PF > 0.8$
- Co-packaged diode (D version)

Main benefits

- Extremely low conduction losses
- Excellent switch-on performance guaranteed by co-packaged diode (D version)

W (ultrafast) series

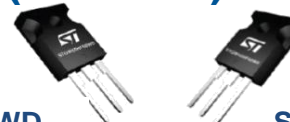

STGW35HF60WD

STGW45HF60WD

Key features

- Operating frequency over 100 kHz
- No cross-conduction susceptibility
- Ultrafast soft-recovery anti-parallel diode

Main benefits

- More stable switching performance (E_{off}) versus temperature
- Extremely low power dissipation

DC-AC (unfolding inverter): standard SCRs

8 / 12 A, 600 / 800 V standard SCRs

Key features

- Repetitive peak off-state voltage, V_{DRM}/V_{RRM} 600 and 800 V
- Triggering gate current, I_{GT} 5 to 15 mA
- Non repetitive surge peak on-state current, I_{TSM} 70 A up to 140 A
- Switched at line frequency

Main benefits

- Reverse blocking capability (mandatory for AC line connection)
- Low forward voltage drop
- ZCS operation
- High reliability

TO-220AB

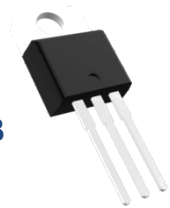

TYNx08RG
TYNx12RG
TYNx12TRG

DDPAK



TN805-x00B
TN815-x00B



DC-DC/DC-AC*: IGBT/MOSFET protections

20

Key features

- Improved power derating vs. temperature
- Application oriented datasheet

Main benefits

- Better protection with smaller package vs. competition
- Customer design effort reduced
- Transil™ over sizing avoided
- Reduced standby power consumption vs. discrete protection
- Improved clamping voltage accuracy
- Space saving vs. discrete solution

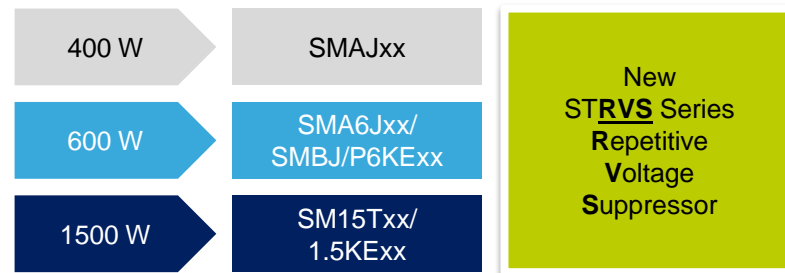

DC-DC/DC-AC: STM32 microcontrollers

High-performance ARM Cortex-M MCUs

Key features

- More than 250 compatible devices
- 16-Kbyte to 1-Mbyte Flash
- 36 to 176 pins
- From low cost ...
... to high performance

Main benefits

- Real-time performances
- Superior and innovative peripherals
- Maximum integration
- Extensive tools and software

STM32 Portfolio



www.BDTIC.com/ST

ST products for auxiliary SMPS

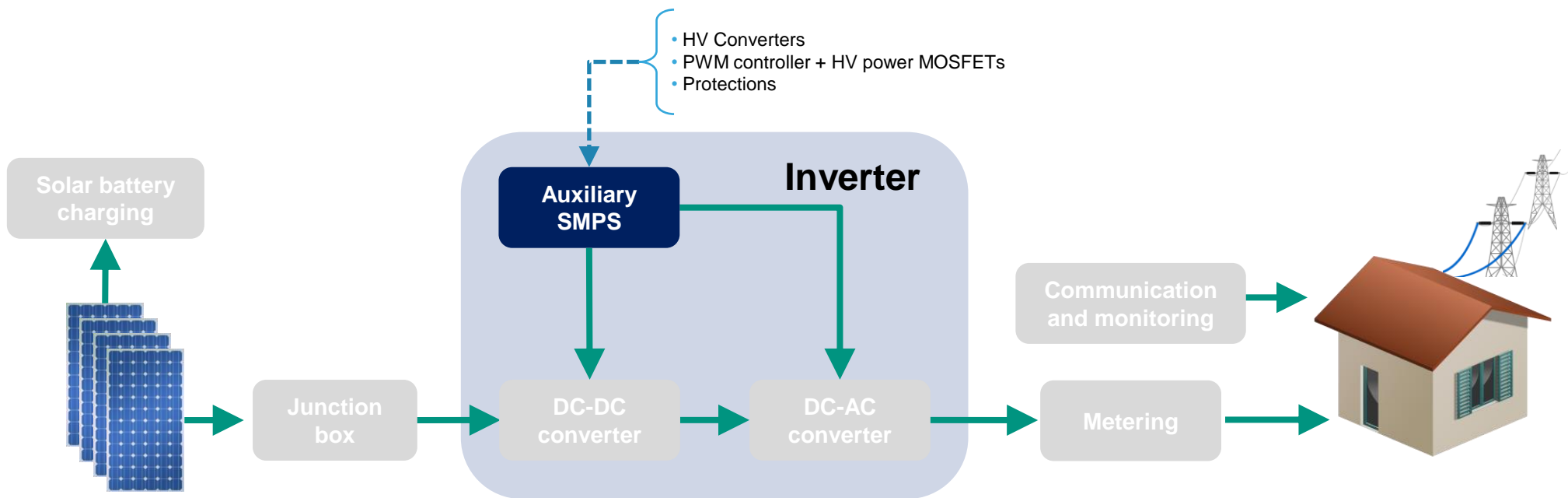

Auxiliary SMPS: VIPerPlus family

VIPerPlus: Designed for Power Efficiency

Key features

- Multichip: BCD6S for control and SuperMesh™ for rugged power section
- Fixed frequency with jittering (VIPerx6/x7/x8) or quasi-resonant operation (VIPerx5)



Main benefits

- High efficiency (> 80%)
- Standby power < 30 mW
- 800 V avalanche-rugged power section
- Embedded advanced protection for high PSU reliability

VIPerPlus = VIPer plus

+ Technology	+ Robustness
+ Functions	+ Efficiency
+ Protections	+ Intelligence

www.BDTIC.com/ST

ST products for metering

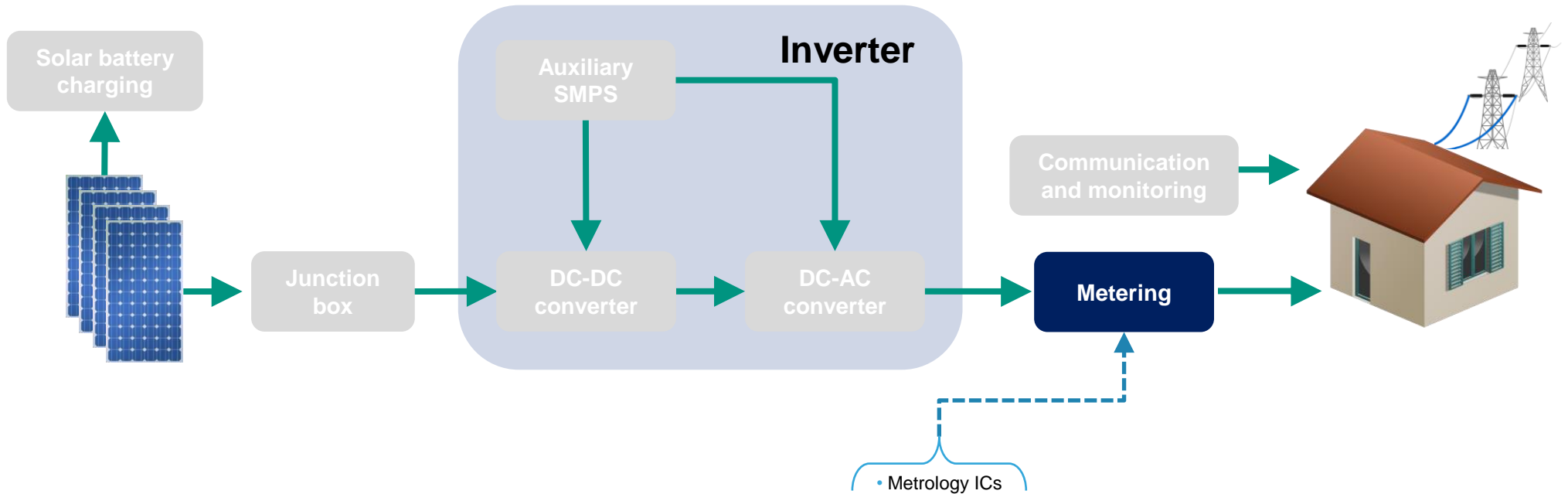

Metering: Metrology ICs - STPMxx family

Key features

- STPMxx multiple cost-effective metering IC solutions for single-phase
- STPMC1, STPMS2: the first modular metering chip set solution for poly-phase
- Multiple measurements
- Multiple sensors support

Main benefits

- High accuracy
- Fast digital calibration
- Anti tamper

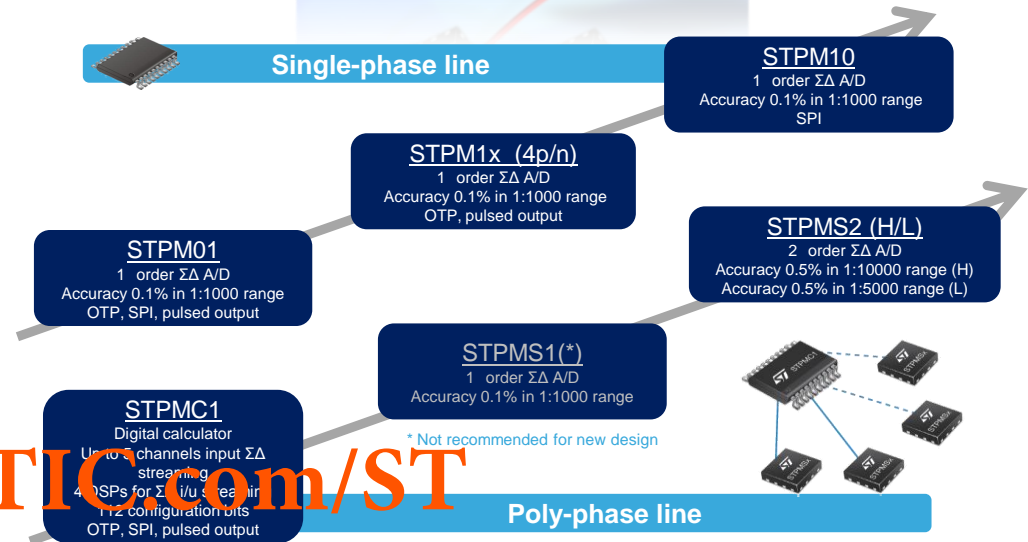
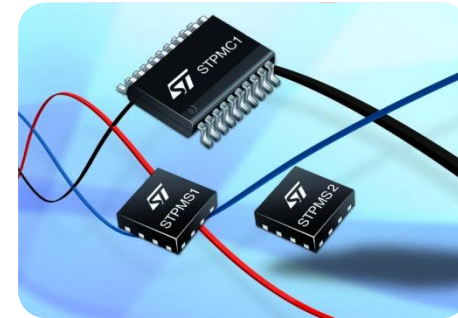

ST products for communication and monitoring

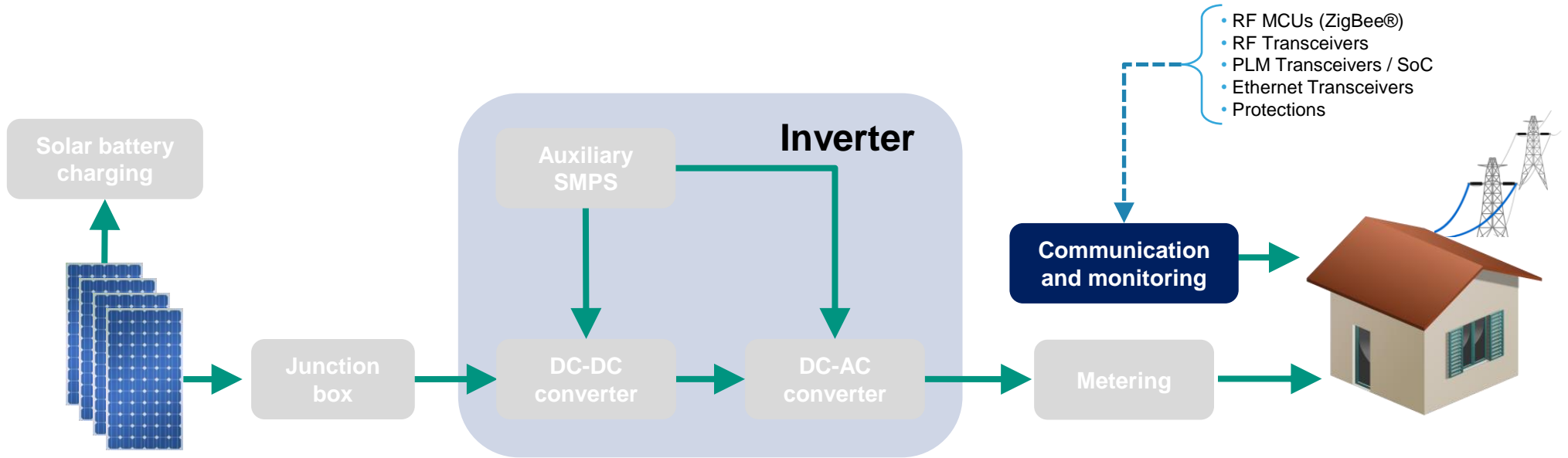

RF Transceivers – SPIRIT1

Flexible low power **proprietary sub GHz transceiver** with integrated packet handler

Key features

- Designed to work on the following frequency bands: 150-174 MHz, 300-348 MHz, 387-470 MHz, 779-956 MHz
- Supports the following modulation schemes: 2-FSK, GMSK, GFSK, MSK, OOK and ASK
- Air data rate from 1 to 500 kbps

Main benefits

- Multiple packet configuration
- Integrated SMPS for very low power consumption vs. competition



Integrated 2.4 GHz radio MCU enables efficient and low-cost wireless network implementation

Key features

- Industry-leading RF performance
 - ZigBee IP SEP 2.0 platform
 - ZigBee RF4CE certified platform
 - IEEE 802.15.4 certified platform
- Part of largest ARM Cortex-M3 product family: STM32

Main benefits

- Excellent RF performance
- Low power consumption (0,4 μ A with RAM retention)

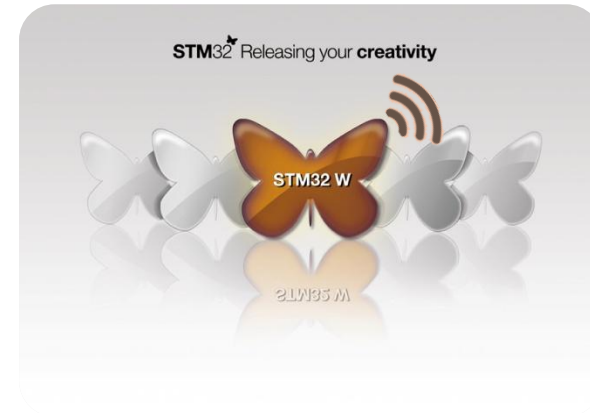

STM32W108C8
STM32W108CB
STM32W108CC
STM32W108CZ
STM32W108HB



STarGRID power line modem SoC platform

ST7540, ST7570, ST7580, ST7590 : from command and control to Smart Grids

Key features

- Multiple modulations and protocols
- All PLC system blocks embedded in a single chip
- Embedded messages encryption
- Not proprietary modulations, no royalties
- “Turn-key” implementations available compliant with major protocol specifications such as IEC61334-5-1, PRIME and others

Main benefits

- High modularity and flexibility
- Highest integration
- High scalability
- Openness



www.BDTIC.com/ST

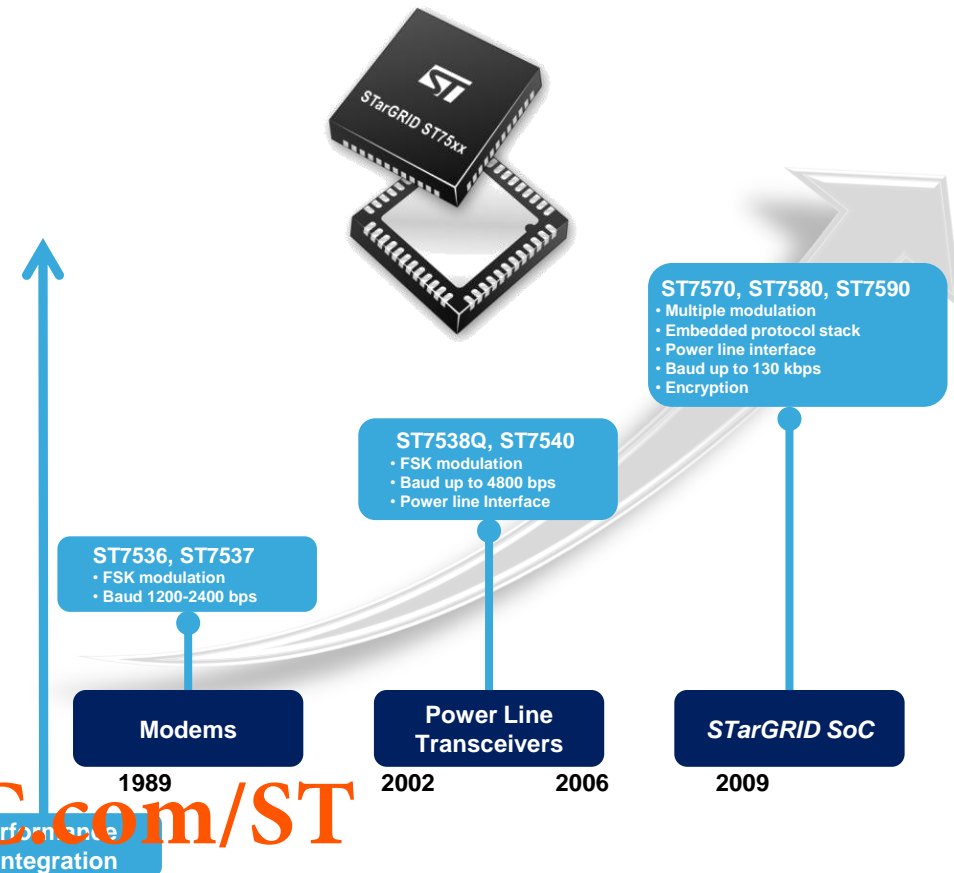

Power line communication - protections

30

Key features

- High energy surges protection
- Protection device transparency vs. data transfer
- Bidirectional protections
- Transil™ and Trisil™ available in ST portfolio for multiple protection topologies

Main benefits

- No ageing effect & high reliability over time
- Voltage clamped accurately by Transil™ vs. MOV
- Small packages & high surge capability

Trisil™

SMP100LC-xx
SMPxxx0SMC « *New Generation* »

Transil™

SMA6JxxCA
SMBJxxCA/SM6TxxCA
SM15TxxCA



Key features

- 10BASE-T, 100BASE-TX (ST802RT1A/B), 100BASE-FX (ST802RT1B only), IEEE 802.3u compliant, half/full duplex mode
- Single supply voltage: 3.3 V

Main benefits

- Extended temperature range: -40 to +105 C
- Fiber and cable support



ST802RT1A
ST802RT1B

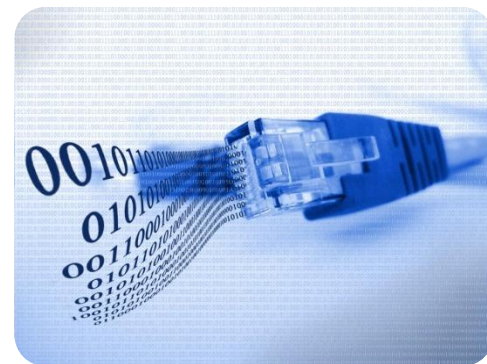

Key features

- Low capacitance devices
- Transil™ and Trisil™ available in ST portfolio for multiple protection topologies
- Multiple pin-out configurations

Main benefits

- Compliant with all telecommunication standards
- Protection device transparency vs. data transfer

Ethernet speed	10/100 Mbps	1 Gbps
Primary protection	DSL01-008SC5, SLVU2.8-xA1 ETP01-1621, SMPxxx0SMC, SMP100LC	SLVU2.8-8A1 SMP75-8
Secondary protection	HSP061-4NY8	HSP061-4NY8 HSP061-8M16

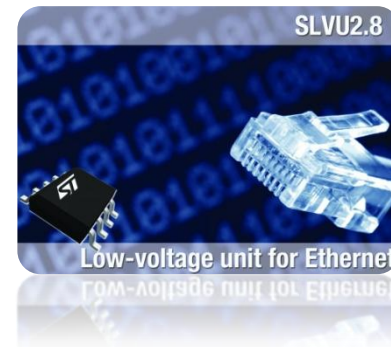

www.BDTIC.com/ST

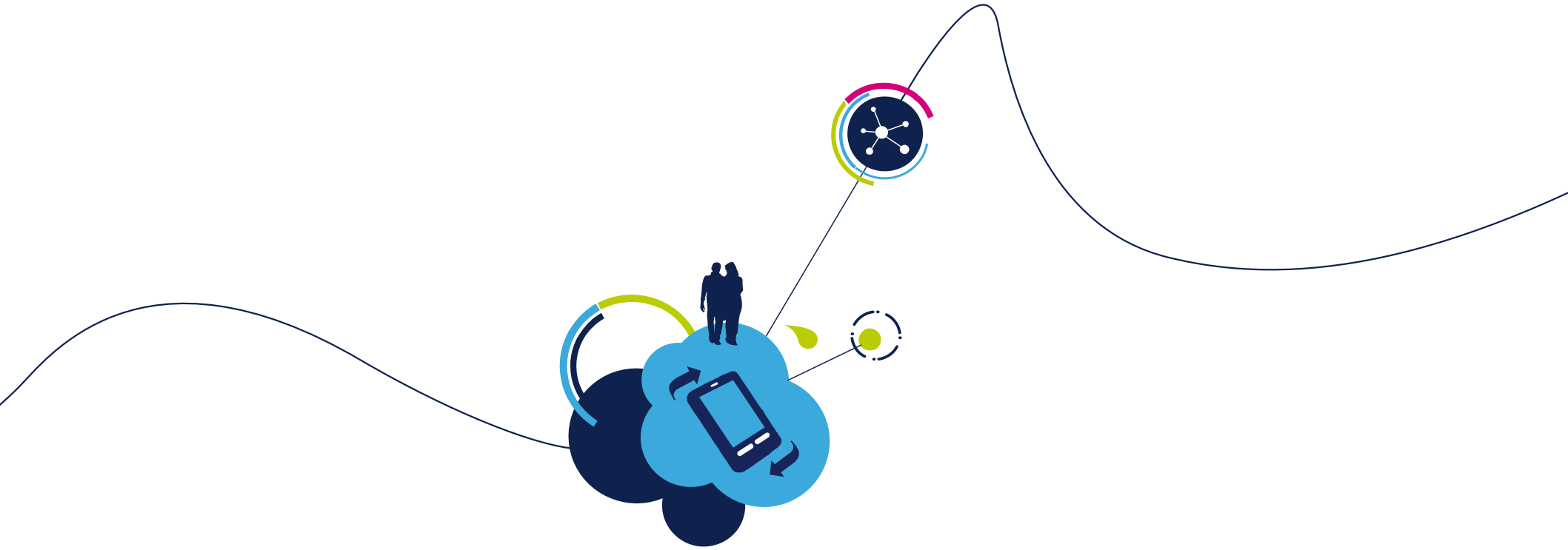

Featured System Solutions for Centralized & Distributed Solar Inverters

www.BDTIC.com/ST

3 kW grid-connected solar inverter

Key features

- High conversion efficiency: up to 96%
- Uses phase-shift DC-DC converter with MPPT plus full-bridge DC-AC
- Galvanic isolation between PV array and grid
- Optimized MPPT algorithm for maximum energy yield from PV array
- Grid-connected algorithm with decoupled control of active and reactive power

Key products

- STM32F103ZE (32-bit Microcontroller)
- STW55NM60ND (Power MOSFETs)
- STGW35HF60WD (IGBTs)
- L6386ED, TD350 (MOSFET/IGBT Drivers)
- STTH60L06, STTH30R06, STTH16L06, STPS3150, STPS5L40 (Diodes)
- ST3232EB (RS-232 interface)
- VIPer17, VIPer27 (Aux. SMPS)

System Architecture

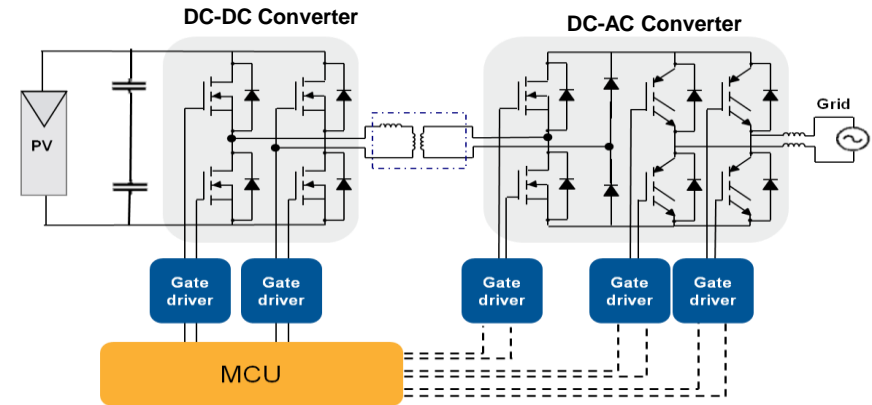

System evaluation board
(STEVAL-ISV002V2 (*))

250 W microinverter for plug-in PV modules

35

DC to AC conversion into a compact system attached directly to each solar module for maximizing energy harvest and for panel diagnostic and monitoring

Key features

- Wide voltage range: 120 Vac / 230 Vac
- Conversion efficiency > 94%
- MPPT efficiency: 99%
- Anti-islanding
- Galvanic isolation between PV panel and grid
- Grid-connected algorithm with decoupled control of active and reactive power

Key products

- STM32F103ZE (32-bit microcontroller)
- STB18N65M5, STH180N10F3-2 (power MOSFETs)
- PM8834, L6390 (MOSFET drivers)
- STPSC606, STPS1545C, STTH12R06 (diodes)
- SMBJ (EOS surge protection)
- ST3232EB (RS-232 interface)

System Architecture

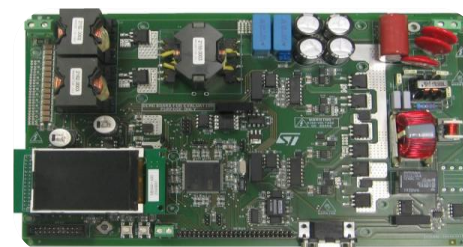
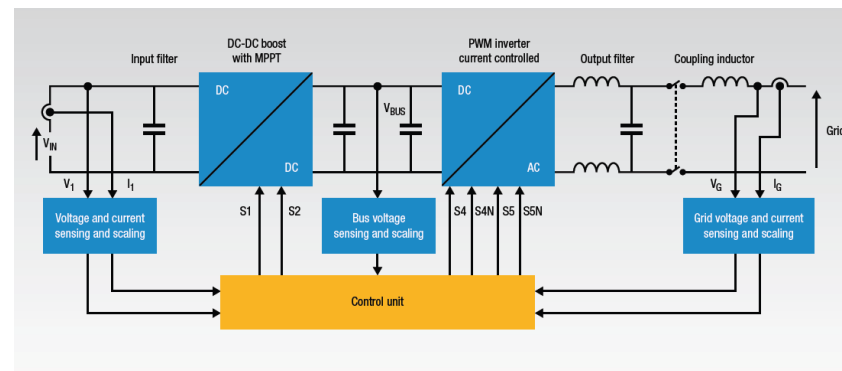

System evaluation board
(STEVAL-ISV003V1)

300 W low voltage power optimizer for standard PV panels

36

Key features

- 300 W DC-DC Boost Converter with MPPT
- 40V output voltage operating range
- Built-in MPPT and Soft-Start
- Output over voltage and over temperature control
- Efficiency > 98%
- SPI interface for remote telemetry and control

Key products

- SPV1020 (Solar Energy Booster)
- SPV1001N30, SPV1001N40 (Cool Bypass Switch)
- STPS160U (Power Schottky Diode)

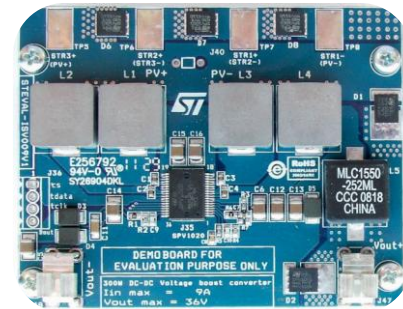
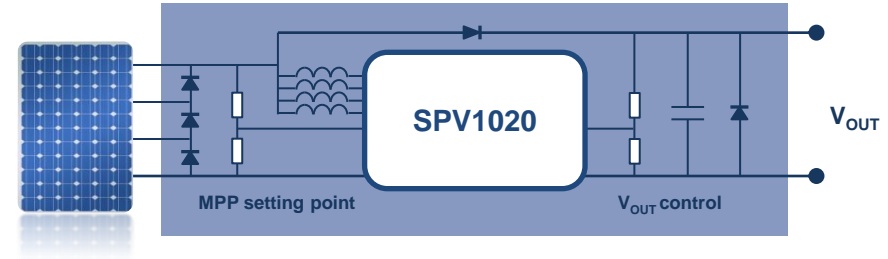

System evaluation board
(STEV009V1)

250 W high voltage power optimizer platform

37

Smart Power System which combines DC-DC conversion and distributed MPPT at panel level with monitoring of panel key parameters and safe PV operations

Key features

- Isolated DC-DC boost converter with embedded MPPT
- High conversion efficiency (97%)
- PLM or ZigBee connectivity through daughter board
- Remote and safe panel disabling
- Antitheft

Key products

- SPV1001 (cool bypass switch)
- STM32F103CB (32-bit microcontroller)
- STTH12R06, STPS2H100 (diodes)
- STH180N10F3-2 (STripFET power MOSFET)
- ST7580 (Power line transceiver)
- SPZB32W1x2.1 (ZigBee module)

System Architecture

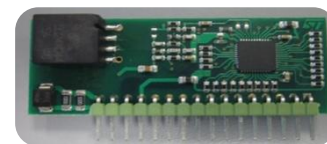
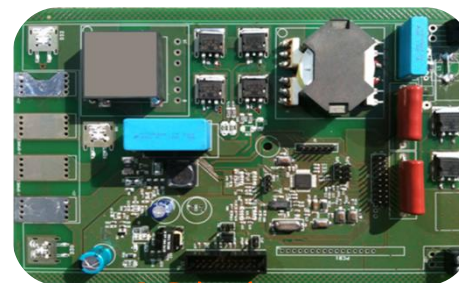
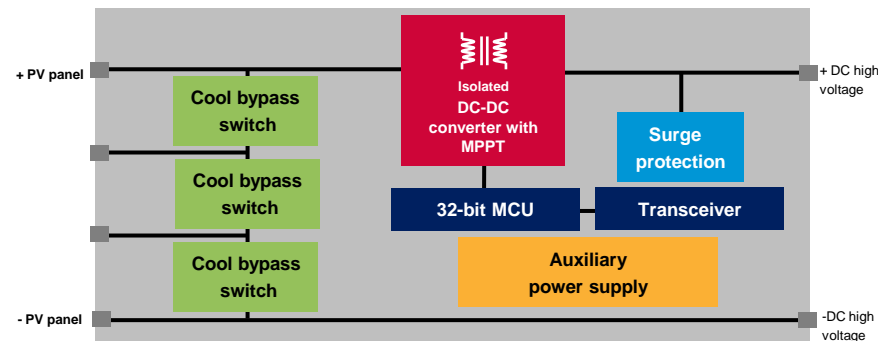

ST products for solar battery charging

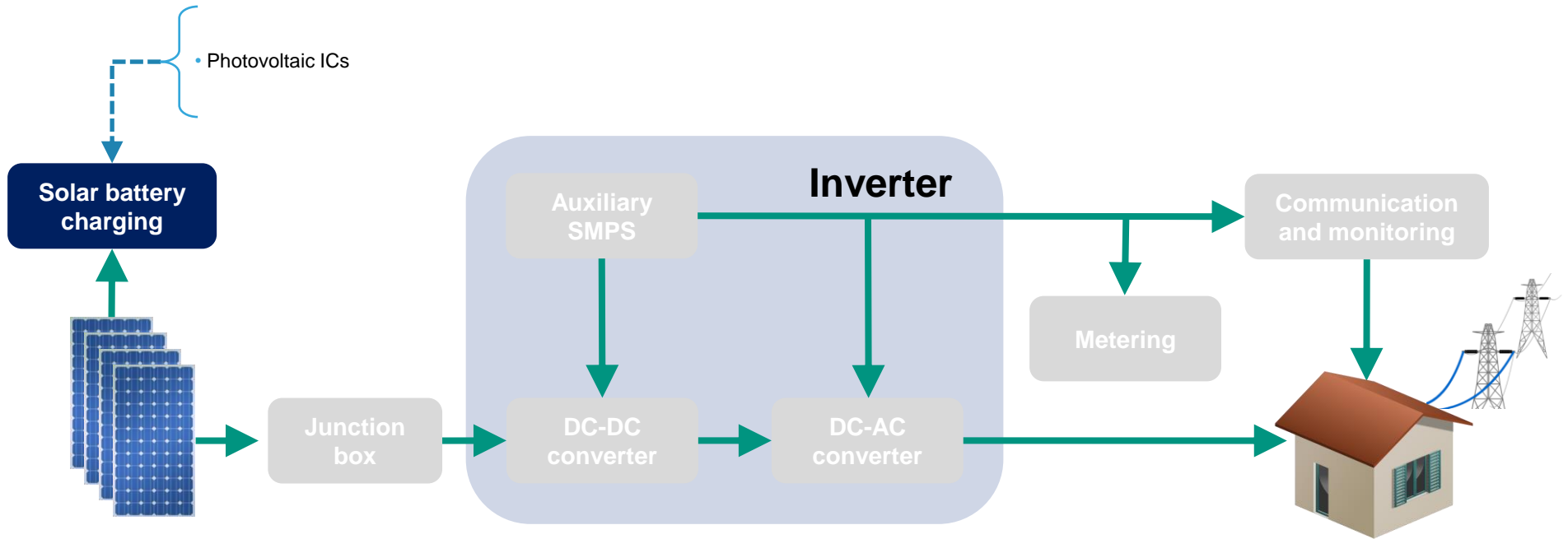

SPV1040: solar battery charger

Key features

- High-efficiency monolithic step-up DC-DC converter
- Proprietary Perturb and Observe embedded MPPT algorithm
- Very low input voltage (down to 0.3 V)
- Very low RDS(on) integrated N-MOSFET and P-MOSFET
- Over-current and over-temperature protection
- Input reverse polarity protection



Main benefits

- Maximized energy harvesting
- Up to 95% efficiency
- Optimized battery charging profile
- Suitable for low-power applications powered by only a few solar cells
- Battery and system safety guaranteed

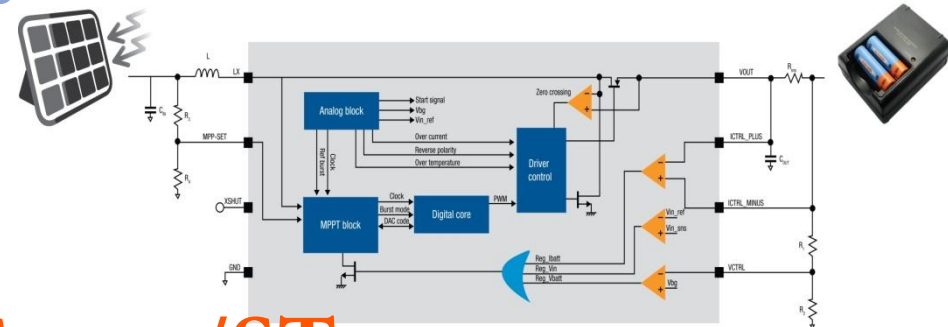

www.BDTIC.com/ST

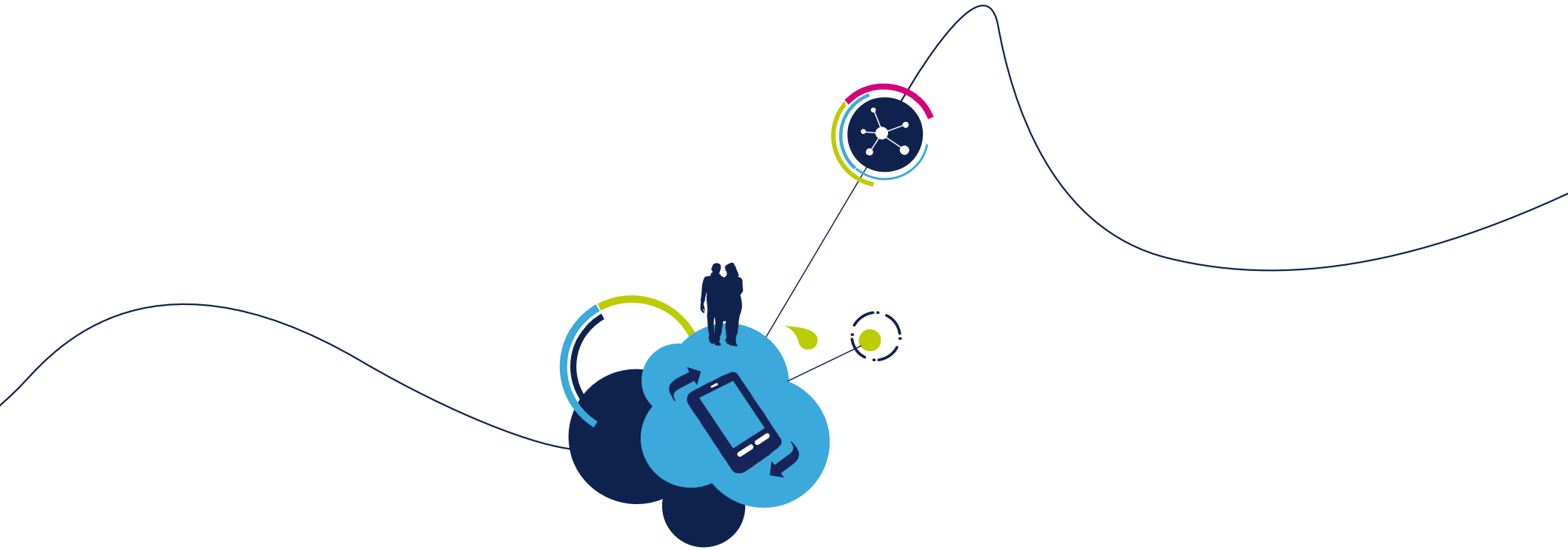

Featured System Solutions for Solar Battery Chargers

www.BDTIC.com/ST

Up to 5W solar battery charger based on SPV1040

Key applications

- Home lighting
- Small appliances
- Smart phones and wireless headsets
- Portable consumer devices and toys
- Solar lanterns
- Digital still cameras
- Portable healthcare, sensors



Key products

- SPV1040: high-efficiency solar battery charger with embedded MPPT
- L6924D (Option for Li-Ion batteries, STEVAL-ISV012V1)



www.BDTIC.com/ST System evaluation board
(STEVAL-ISV006V2)

240 W solar battery charger based on SPV1020

Key features

- Lead Acid Battery charger from PV panel
- Built-in MPPT and Soft-Start
- Input and output over current control
- Output over voltage control
- Internal over temperature control
- Efficiency > 98%
- SPI interface



Key products

- SPV1020 (Step-Up DC-DC Converter with embedded MPPT)
- SEA05 (CV-CC Controller)

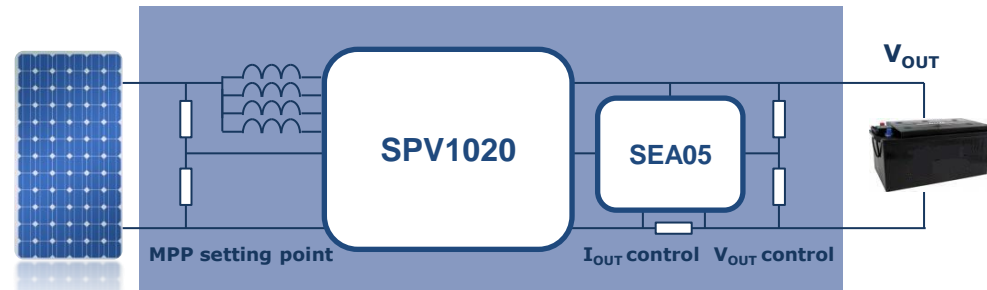

Solar-LED streetlight controller

80 W solar battery charger with 25 W LED lamp driver featuring automatic day/night detection and battery/mains switchover

Key features

- Maximum power point tracker (MPPT) for more efficient energy use
- Constant current control for LED lamp
- Battery charge control with temperature monitoring
- Easy system monitoring via debug indicators
- Full protection function for battery, LED lamp and solar panel

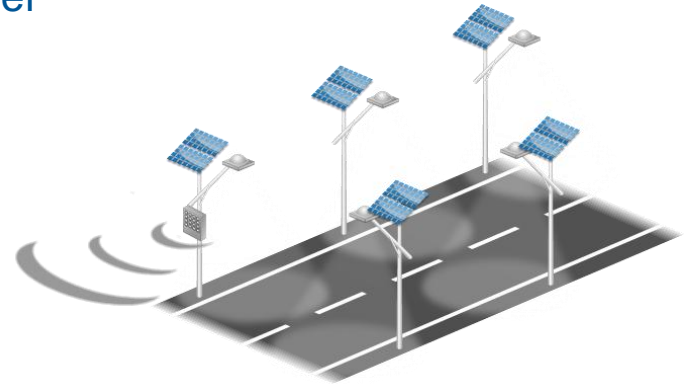

Key products

- STM32F101R6 (32-bit microcontroller)
- STP40NF10, STP75NF75 (LV Power MOSFETS)
- STPS20H100C, STPS1H100, STPS2045C, STPS1L60 (Power Schottky Diodes)
- TSC101 (Current Sense IC)



System evaluation board
(STEVAL-ILL022V1(*))