



STEVAL-IPE005V1, STPM01 programmer board - hardware

Introduction

The STPM01 - programmer kit works in conjunction with the STPM01 energy meter ASSP device and with the STPM01 manager software. It is an integrated system designed to provide the user with a complete, ready-to-use energy meter application. The reference design is a high-end solution for power metering based on the STR710 microcontroller with an embedded RTC and an external memory interface (EMI) ready to drive 1Mbyte of on-board SRAM.

The kit also integrates an on-board optical insulated serial line allowing isolation of the board ground reference in order to avoid propagation of overvoltage on the PC side.

Moreover, the on-board charge pump allows burning the STPM01 energy meter ASSP device registers.

Access to the STPM01 device registers is ensured using a dedicated SPI bus interface.

The STPM01 programmer kit demonstrates how effectively the STPM01 can be used in real-world energy meter applications and it helps the user to develop his own application.

The STPM01 programmer kit can be used in two ways:

- For demonstration purposes, by connecting the reference design to an AC power source and changing all the settings parameters through the GUI interface and the hardware programmer/reader board
- To evaluate and develop a custom application

Contents

- 1 Overview 4**
 - 1.1 Recommended reading 4
 - 1.2 Getting technical support 4

- 2 STPM01 kit components 5**
 - 2.1 Package checklist 5
 - 2.2 Debug 5
 - 2.3 Reset 5
 - 2.4 Power supplies 5
 - 2.5 Opto-isolated RS-232 5
 - 2.6 SPI connector 5
 - 2.7 Status LEDs 6
 - 2.8 Jumper placement 6
 - 2.9 Jumper position 7
 - 2.10 Description of push-buttons and default value 8
 - 2.11 Description of connectors 8
 - 2.12 Boot configuration 9

- 3 Connectors 10**
 - 3.1 Power 10
 - 3.2 UARTx 10
 - 3.3 Debug 11

- 4 STPM01 programmer kit schematics 12**
 - 4.1 Microcontroller and main parts schematic 12
 - 4.2 Power management 13
 - 4.3 Reset and clock circuits 14
 - 4.4 Boot management and Jtag circuit 15
 - 4.5 External RAM memory 17
 - 4.6 SPI signals buffering 18
 - 4.7 Charge pump and SPI connector 19

- 5 Revision history 20**

List of figures

Figure 1.	STPM01 programmer kit option jumper placement	6
Figure 2.	Jumper position	7
Figure 3.	STPM01 programmer kit: placement of connectors.	8
Figure 4.	Power jack connector: CN2	10
Figure 5.	RS232 transmit and receive connectors.	10
Figure 6.	JTAG standard interface: CN1	11
Figure 7.	Microcontroller and main parts schematic	12
Figure 8.	Power management schematic	13
Figure 9.	Reset and clock circuits	14
Figure 10.	Boot management and Jtag circuits	15
Figure 11.	Opto-isolated UART	16
Figure 12.	External RAM memory	17
Figure 13.	SPI signals buffering.	18
Figure 14.	Charge pump and SPI connector	19

1 Overview

1.1 Recommended reading

This documentation describes how to configure and use the STPM01 programmer kit hardware. Additional information can be found in the following documents:

- Datasheets of ST devices
- Datasheets of third party devices
- Dedicated application notes
- STPM01 programmer firmware user manual
- STPowerMeter user manual

1.2 Getting technical support

Technical assistance is provided free to all customers. For technical assistance, documentation, information and upgrades about products and services, please refer to your local ST distributor/office.

STMicroelectronics offers its customers a free technical support service at metering@st.com and on www.st.com/meteringsupport.

2 STPM01 kit components

2.1 Package checklist

The STPM01 kit package includes the following items:

- The STPM01 board
- A CD-ROM with software and documentation

2.2 Debug

Software debug is via a standard 20-pin JTAG connection.

2.3 Reset

The reset sources are:

- Power-on reset
- Push-button reset
- JTAG reset from an in-circuit emulator

2.4 Power supplies

Power to the board is supplied using a lump in cord power supply providing 5 V to the board. All other required voltages are provided by on-board voltage regulators or voltage convectors.

An isolated 5 V DC/DC provides the isolated voltage supply for the opto-coupler devices.

2.5 Opto-isolated RS-232

A general-purpose, asynchronous serial I/O data port is connected through 9-pin D-type male connectors. The port is opto-isolated in order to avoid overvoltage on the PC side.

2.6 SPI connector

A devoted SPI connector allows interfacing the STPM01 device. It provides all the SPI signals required to communicate with the STPM01 interface registers. Moreover it provides a 24 V line which allows burning the STPM01 configuration registers.

2.7 Status LEDs

Table 1. Status LEDs

LED	Description
D1	+5 V power
D2	+3.3 V power
D3	1.8 V power

2.8 Jumper placement

Figure 1. STPM01 programmer kit option jumper placement

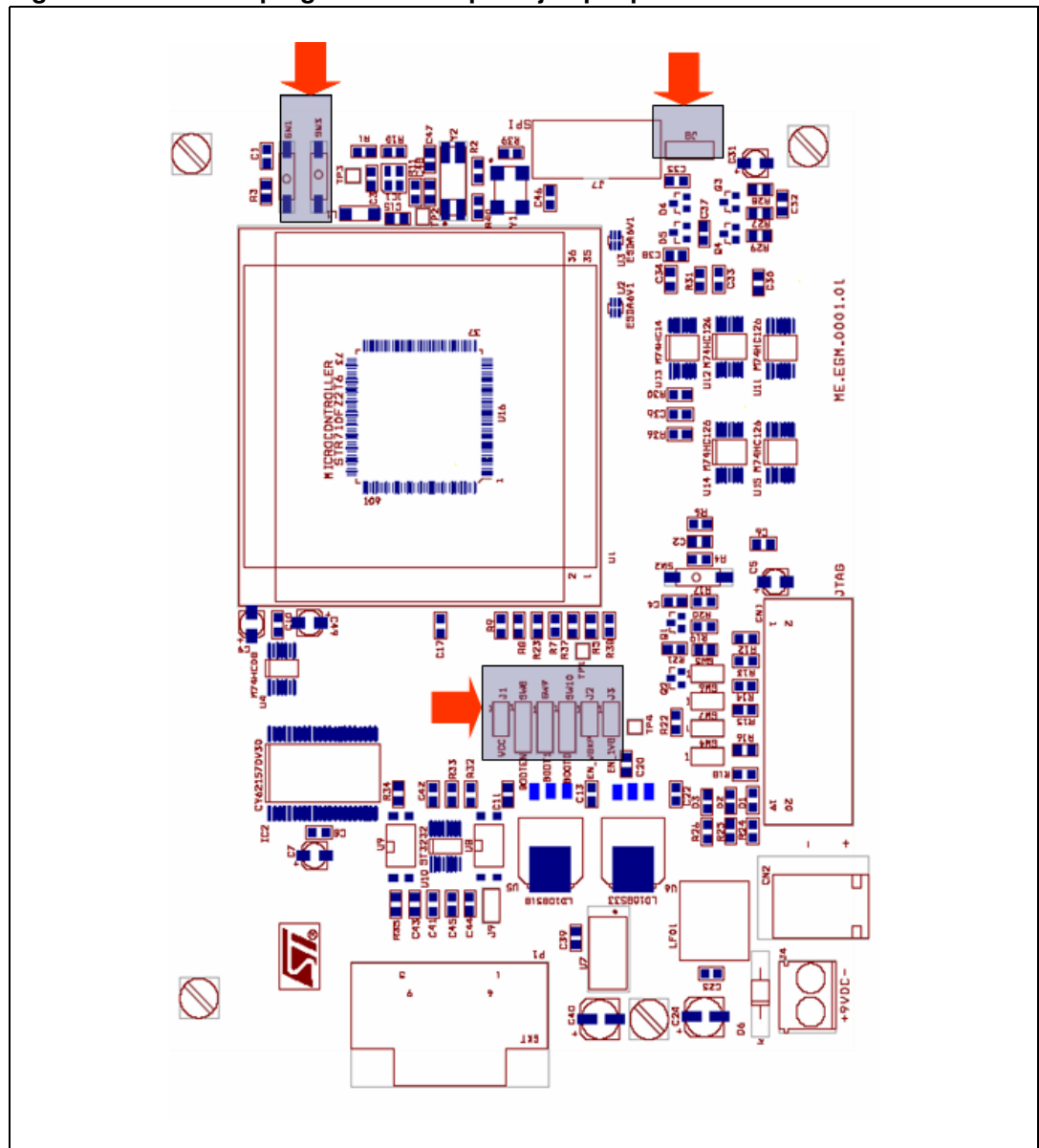

2.9 Jumper position

Figure 2. Jumper position

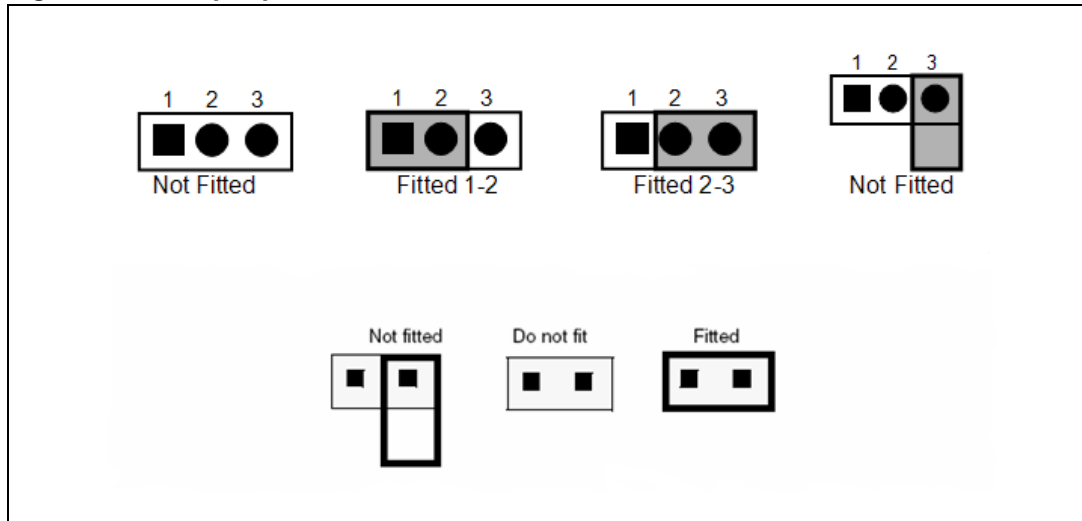

Table 2. Jumpers (refer to [Figure 1](#))

Jumper	Description	Default
J1	3.3 V power supply for external SRAM – Fitted: power to the SRAM – Not fitted: no power to the SRAM	Fitted
J2	Enable VBKP (stabilization for low power voltage) – Fitted: stabilization enabled – Not fitted: stabilization disabled	Not fitted
J3	Enable 1.8 V to microcontroller – Fitted: 1.8 V to microcontroller enabled – Not fitted: 1.8 V to microcontroller disabled	Fitted
J8	Power supply to the charge pump: – Fitted (1-2): Internal power supply to charge pump and SPI signals buffer – Fitted (2-3): power supply to charge pump and SPI signals buffer from STPM01 board	Fitted (1-2)
SW8	BOOT EN: – Fitted (1-2): GND – Fitted (2-3): 3.3 V	Not fitted
SW9	BOOT1: – Fitted (1-2): 3.3 V – Fitted (2-3): GND	Not fitted
SW10	BOOT0: – Fitted (1-2): 3.3 V – Fitted (2-3): GND	Not fitted

2.10 Description of push-buttons and default value

Table 3. Push-buttons (refer to *Figure 1*)

Jumper	Description	Default
SW1	Wakeup: – When pushed, wakes up microcontroller	
SW2	Application default: – When pushed, forces default conditions	
SW3	Reset button: – When pushed, forces microcontroller reset	Fitted

2.11 Description of connectors

Figure 3. STPM01 programmer kit: placement of connectors

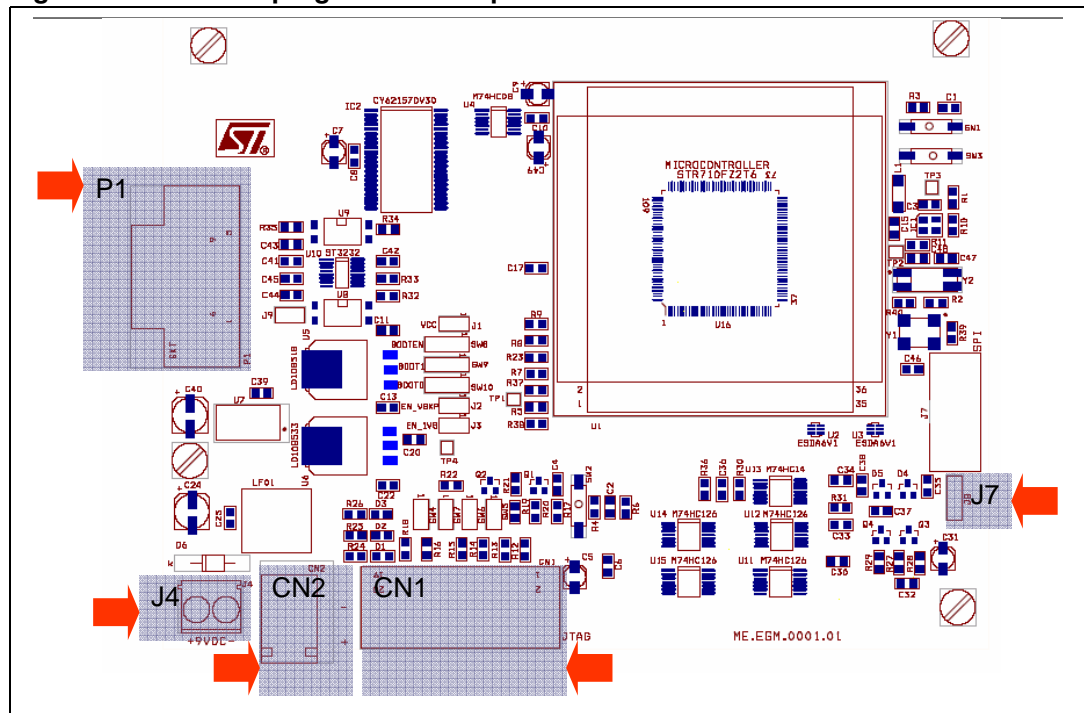

Table 4. Connectors (refer to *Figure 3*)

Connector	Description
P1	Opto - isolated RS232 female connector
J4	DC-IN 5 V connector
CN2	DC-IN 5 V connector
CN1	JTAG connector
J7	SPI connector

2.12 Boot configuration

Table 5. Boot mode

BOOT EN SW8	BOOT1 SW9	BOOT0 SW10	Mode	BOOT memory mapping	Note
0 (1-2))	Any	Any	User	Flash mapped at 0h	System executes code from Flash
1 (2-3)	0 (2-3)	0 (2-3)			
1 (2-3)	0 (2-3)	1 (1-2)	System memory	System memory mapped at 0h	<ul style="list-style-type: none"> – System executes a factory installed boot loader from system memory (reserved mode) – Clock frozen
1 (2-3)	1 (1-2)	0 (2-3)	RAM	RAM mapped at 0h	<ul style="list-style-type: none"> – System executes code from internal RAM – For lab development
1 (2-3)	1 (1-2)	1 (1-2)	EXTMEM	EXTMEM mapped at 0h	<ul style="list-style-type: none"> – System executes code from external memory – Not allowed

3 Connectors

3.1 Power

Figure 4. Power jack connector: CN2

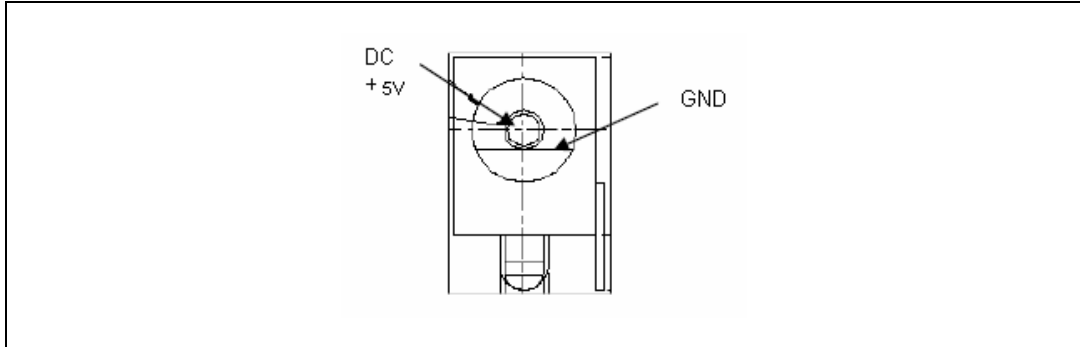

3.2 UARTx

Figure 5. RS232 transmit and receive connectors

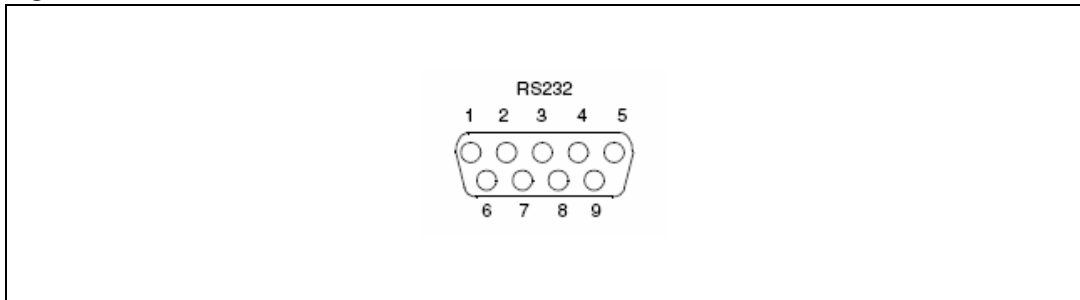

Table 6. RS232 connector pinout P1

Pin	Description
1	Shorted to pins 6 and 2
2	Shorted to pins 1 and 6
3	TX-0_PC (R1IN)
4	RX-0_PC (T1OUT)
5	GND
6	Shorted to pins 1 and 2
7	Shorted to pin 8
8	Shorted to pin 7
9	Not connected

3.3 Debug

Figure 6. JTAG standard interface: CN1

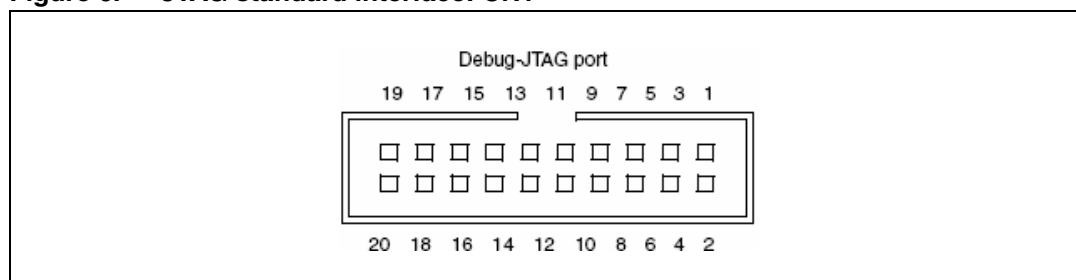
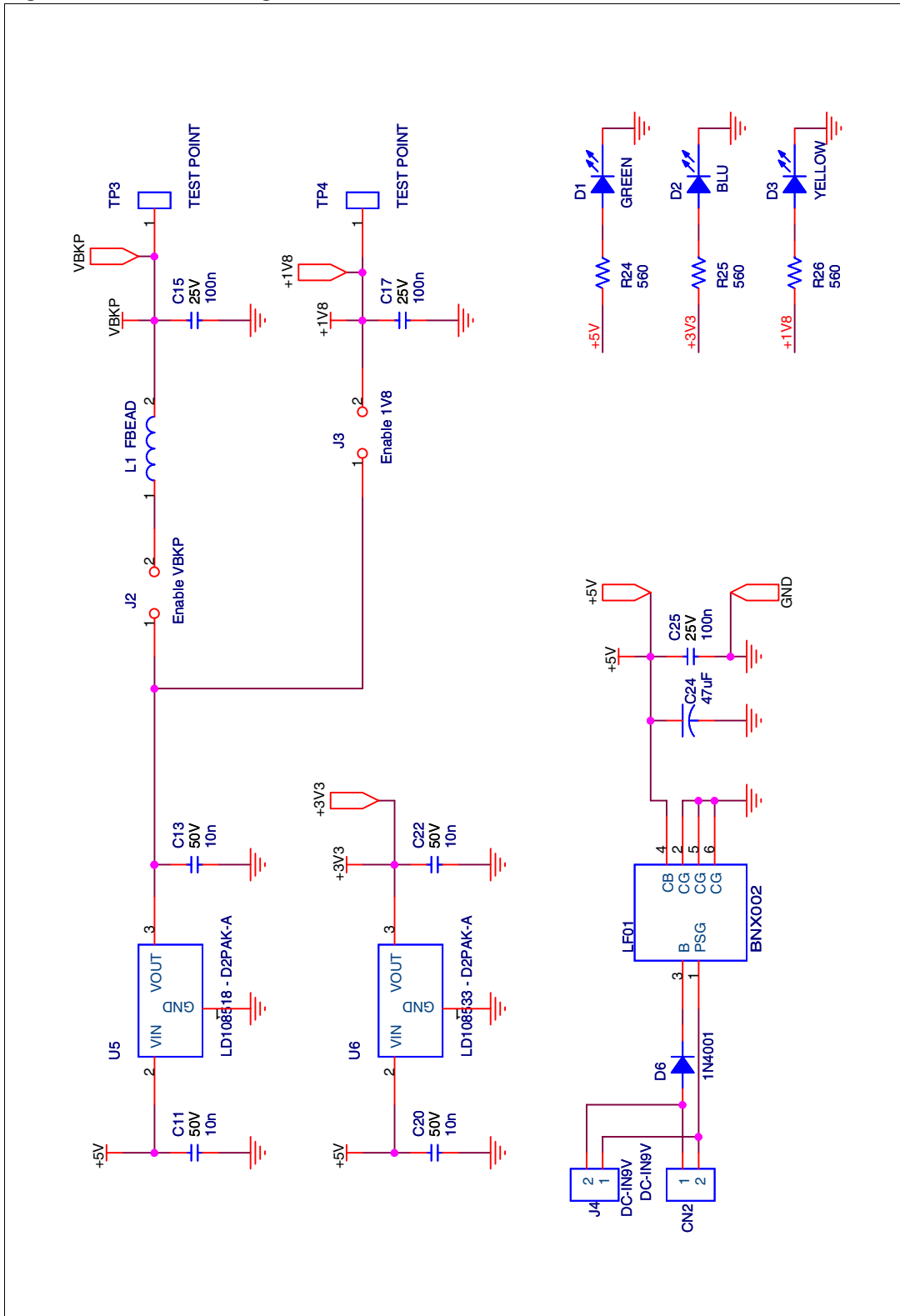

Table 7. JTAG interface pinout: CN10

Pin	Description
Even pins	Ground
1	VTref+3.3 V
2	Vsupply+3.3 V
3	notTRST
5	TDI
7	TMS
9	TCK
11	RTCK (ground)
13	TDo
15	noTReset
17	DBG RQS - pulled down
19	Pulled down

4.2 Power management

Figure 8. Power management schematic



4.3 Reset and clock circuits

Figure 9. Reset and clock circuits

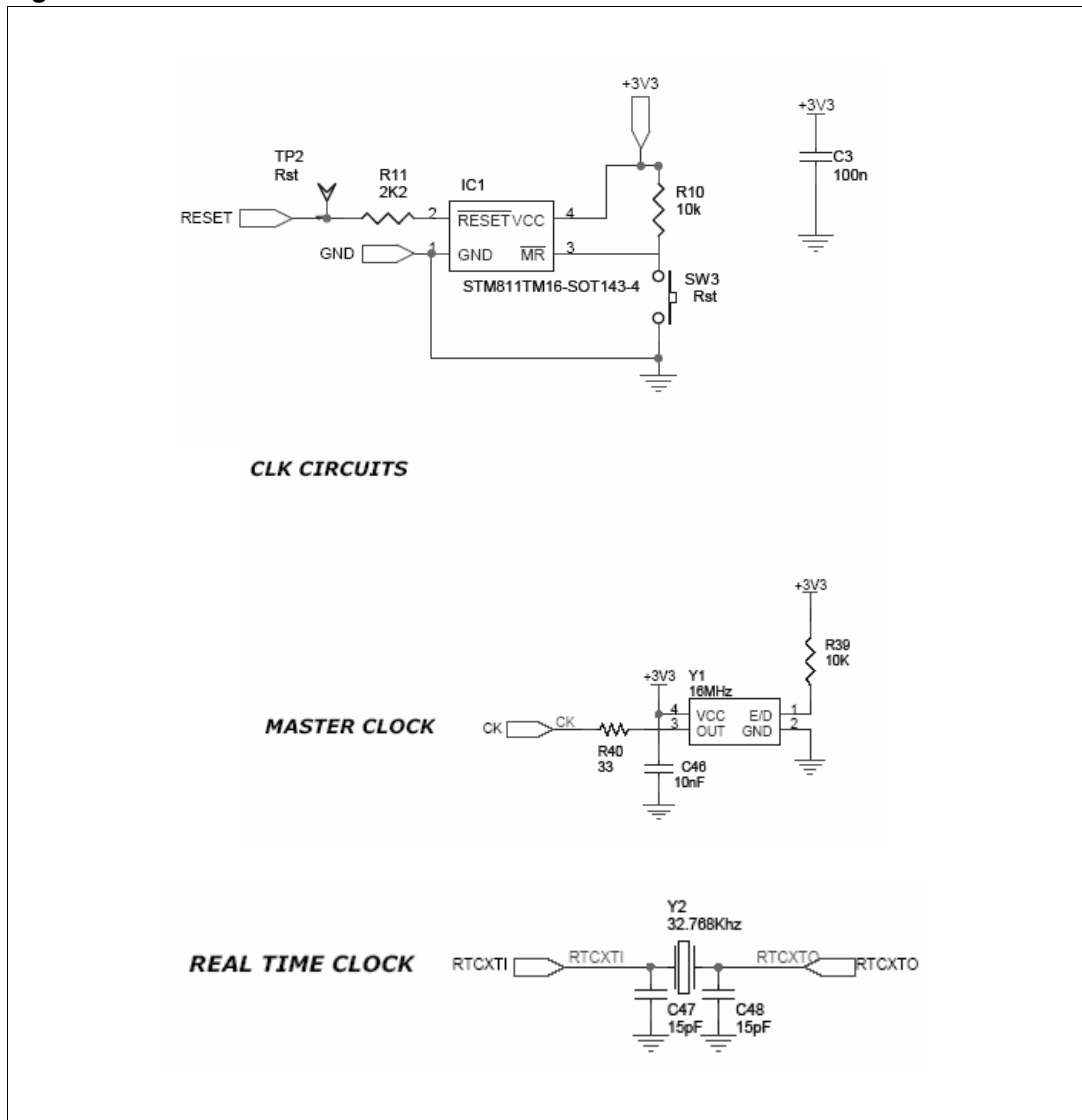
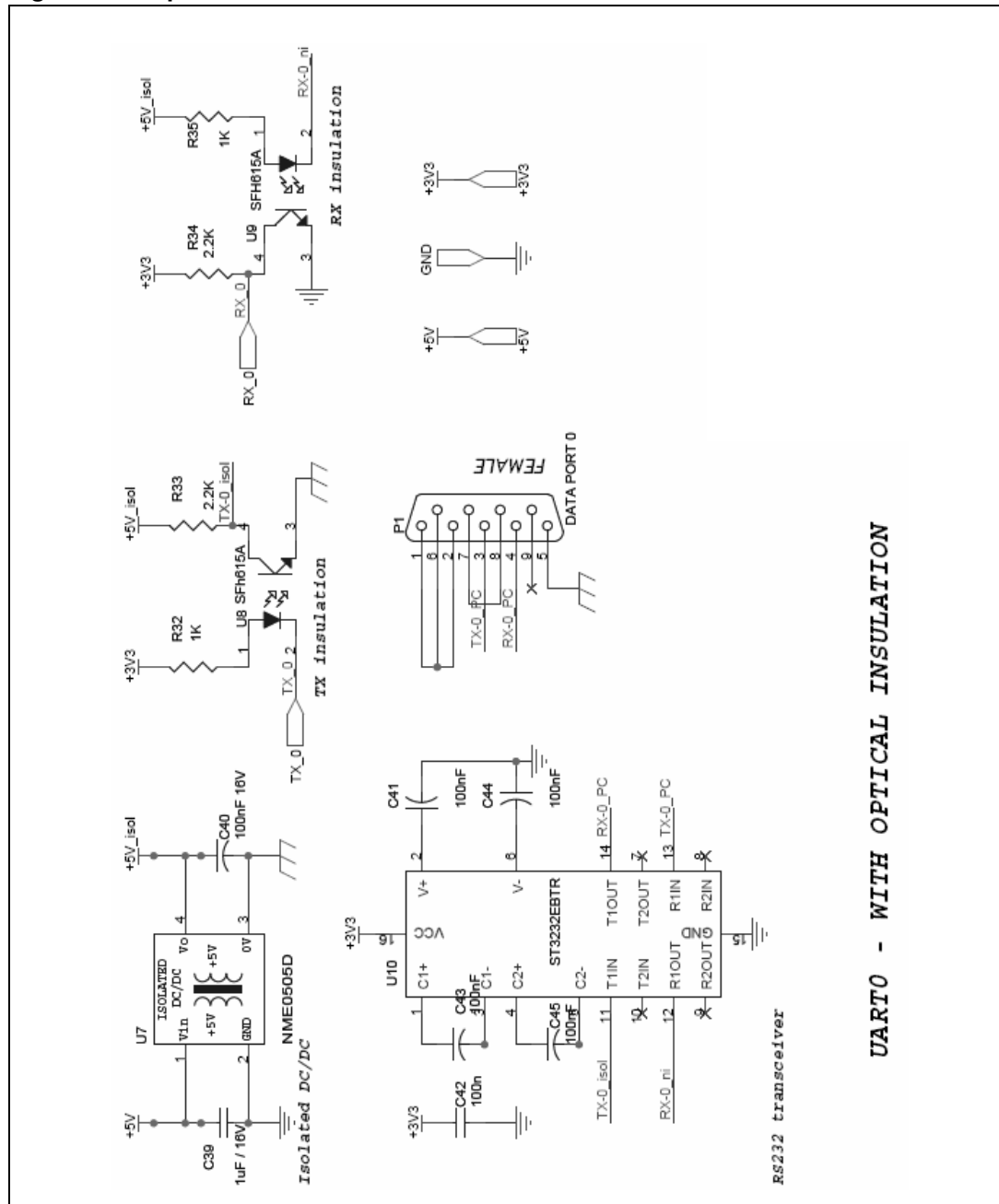

Figure 11. Opto-isolated UART



UART0 - WITH OPTICAL INSULATION

4.5 External RAM memory

Figure 12. External RAM memory

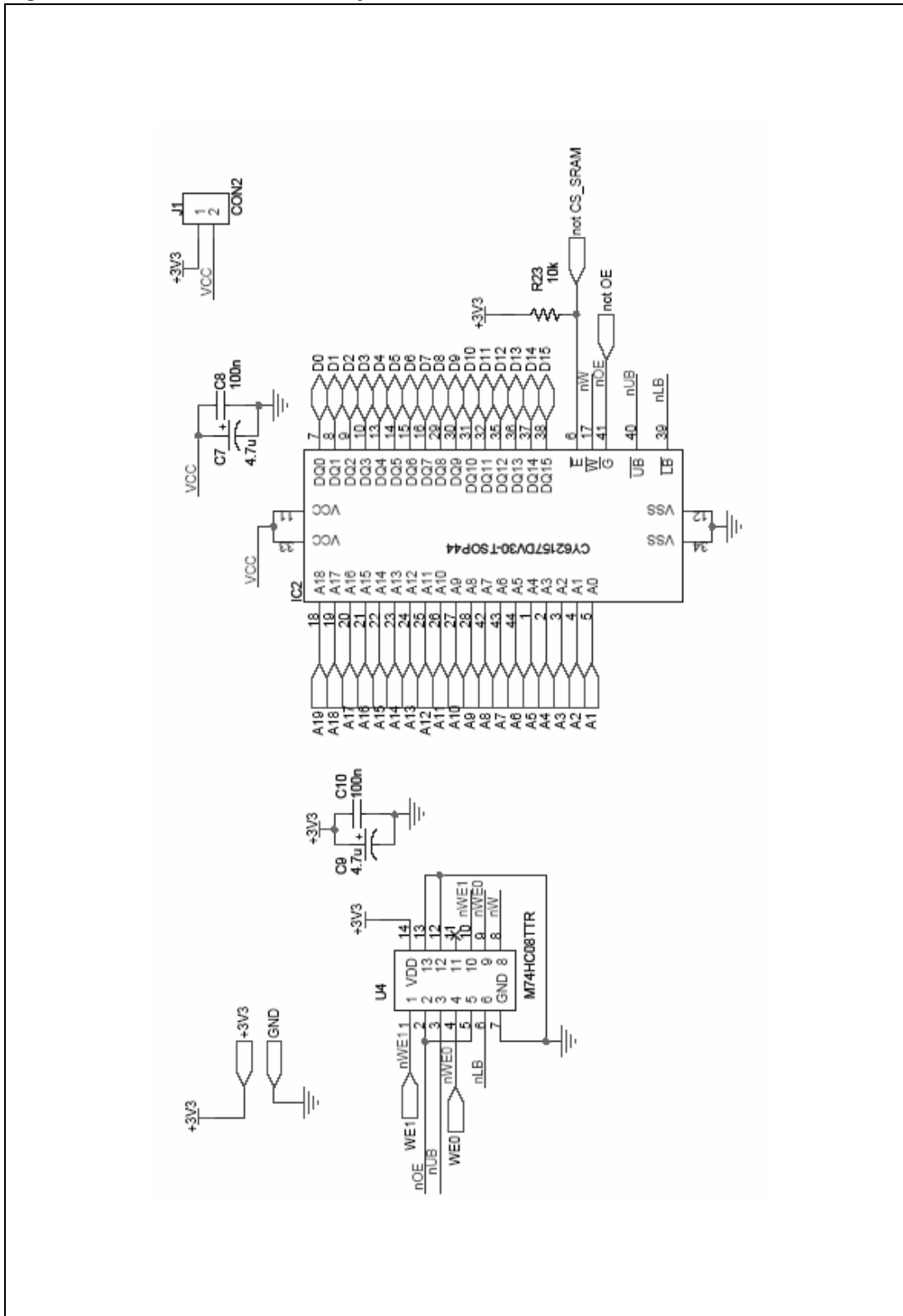

4.6 SPI signals buffering

Figure 13. SPI signals buffering

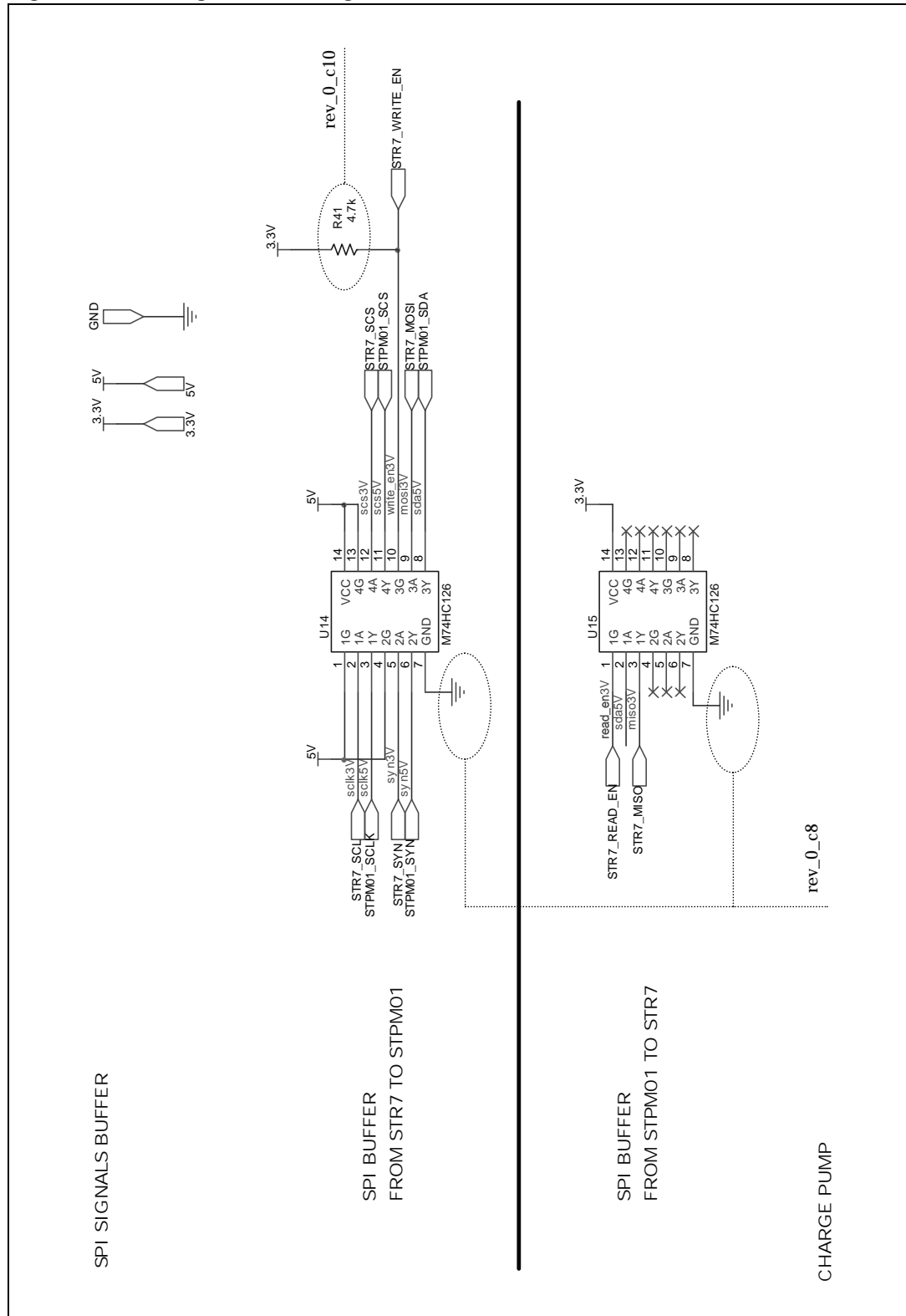

4.7 Charge pump and SPI connector

Figure 14. Charge pump and SPI connector

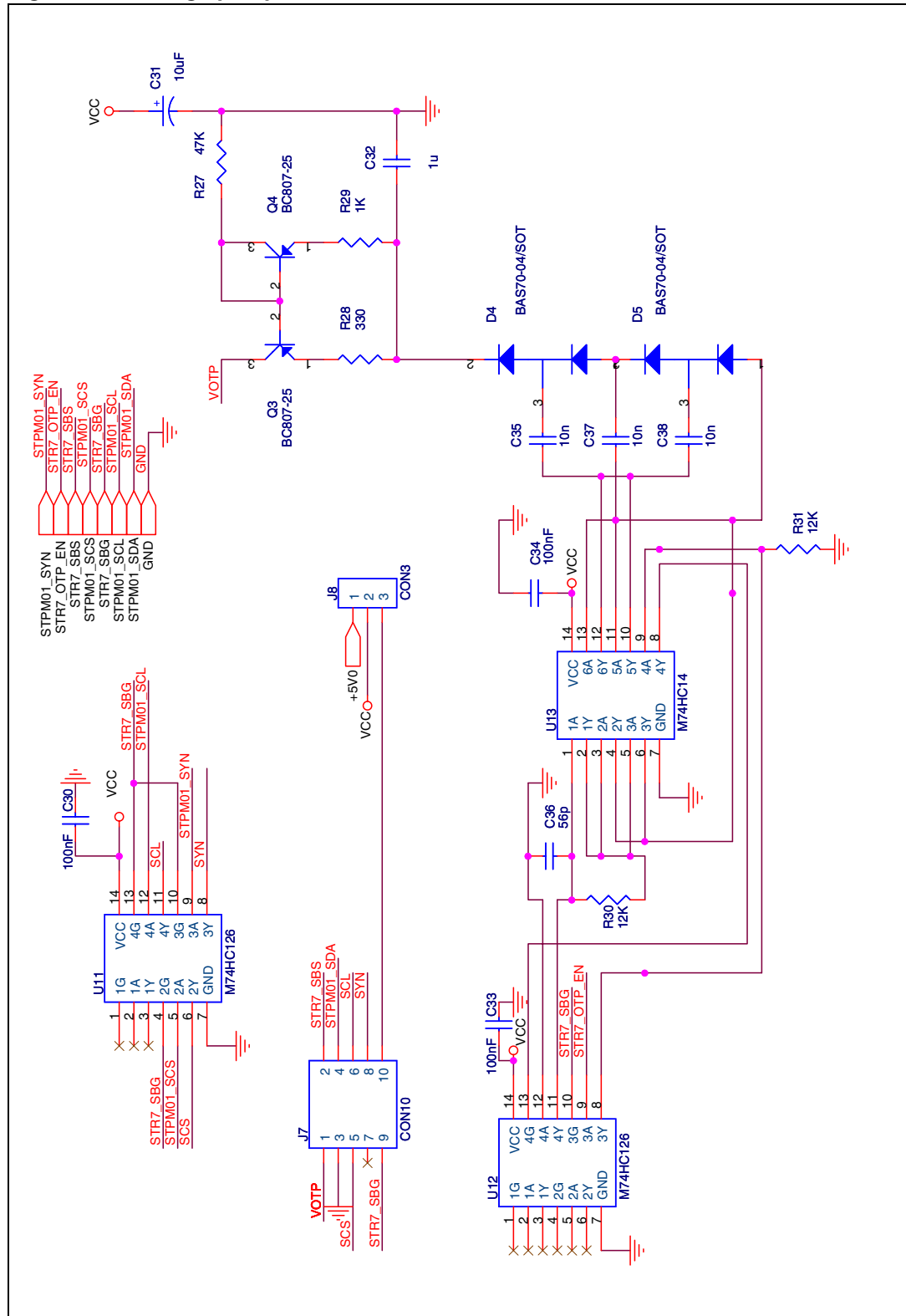

5 Revision history

Table 8. Document revision history

Date	Revision	Changes
14-Mar-2008	1	Initial release

Please Read Carefully:

Information in this document is provided solely in connection with ST products. STMicroelectronics NV and its subsidiaries ("ST") reserve the right to make changes, corrections, modifications or improvements, to this document, and the products and services described herein at any time, without notice.

All ST products are sold pursuant to ST's terms and conditions of sale.

Purchasers are solely responsible for the choice, selection and use of the ST products and services described herein, and ST assumes no liability whatsoever relating to the choice, selection or use of the ST products and services described herein.

No license, express or implied, by estoppel or otherwise, to any intellectual property rights is granted under this document. If any part of this document refers to any third party products or services it shall not be deemed a license grant by ST for the use of such third party products or services, or any intellectual property contained therein or considered as a warranty covering the use in any manner whatsoever of such third party products or services or any intellectual property contained therein.

UNLESS OTHERWISE SET FORTH IN ST'S TERMS AND CONDITIONS OF SALE ST DISCLAIMS ANY EXPRESS OR IMPLIED WARRANTY WITH RESPECT TO THE USE AND/OR SALE OF ST PRODUCTS INCLUDING WITHOUT LIMITATION IMPLIED WARRANTIES OF MERCHANTABILITY, FITNESS FOR A PARTICULAR PURPOSE (AND THEIR EQUIVALENTS UNDER THE LAWS OF ANY JURISDICTION), OR INFRINGEMENT OF ANY PATENT, COPYRIGHT OR OTHER INTELLECTUAL PROPERTY RIGHT.

UNLESS EXPRESSLY APPROVED IN WRITING BY AN AUTHORIZED ST REPRESENTATIVE, ST PRODUCTS ARE NOT RECOMMENDED, AUTHORIZED OR WARRANTED FOR USE IN MILITARY, AIR CRAFT, SPACE, LIFE SAVING, OR LIFE SUSTAINING APPLICATIONS, NOR IN PRODUCTS OR SYSTEMS WHERE FAILURE OR MALFUNCTION MAY RESULT IN PERSONAL INJURY, DEATH, OR SEVERE PROPERTY OR ENVIRONMENTAL DAMAGE. ST PRODUCTS WHICH ARE NOT SPECIFIED AS "AUTOMOTIVE GRADE" MAY ONLY BE USED IN AUTOMOTIVE APPLICATIONS AT USER'S OWN RISK.

Resale of ST products with provisions different from the statements and/or technical features set forth in this document shall immediately void any warranty granted by ST for the ST product or service described herein and shall not create or extend in any manner whatsoever, any liability of ST.

ST and the ST logo are trademarks or registered trademarks of ST in various countries.

Information in this document supersedes and replaces all information previously supplied.

The ST logo is a registered trademark of STMicroelectronics. All other names are the property of their respective owners.

© 2008 STMicroelectronics - All rights reserved

STMicroelectronics group of companies

Australia - Belgium - Brazil - Canada - China - Czech Republic - Finland - France - Germany - Hong Kong - India - Israel - Italy - Japan - Malaysia - Malta - Morocco - Singapore - Spain - Sweden - Switzerland - United Kingdom - United States of America

www.st.com

