

Dual DC-DC converter for powering an AMOLED display based on the STOD02

Introduction

The STOD02 demonstration board is dedicated to showing the performance of the STOD02 dual DC-DC device, which is used to power AMOLED displays up to 3.0" with an input voltage range from 2.5 to 4.5 V.

It integrates a step-up and inverting DC-DC converter, able to deliver the positive and negative voltages needed for the AMOLED panel to operate. Due to the high switching frequency and to the full integration of the synchronous switches, the STOD02 needs very few and small external components, therefore reducing the BOM cost and the PCB area.

At the same time, this small size solution does not penalize the overall performance: efficiency stays above 85 % in the most used range of output current and input voltage while very good line and load transients allow the maintaining of a stable output voltage when the input voltage changes rapidly due to series resistance of the battery.

The STOD02 works in pulse-skipping mode during low load condition and in PWM mode (at 1.6 MHz) for medium/high load conditions. The Enable pin allows the turning off of the device, therefore reducing the current consumption to less than 1 μ A. The negative output voltage can be programmed by an MCU through a dedicated pin which implements S-wire protocol. Soft-start with controlled inrush current limit and thermal shutdown are integrated functions of the device.

Figure 1. Typical application schematic

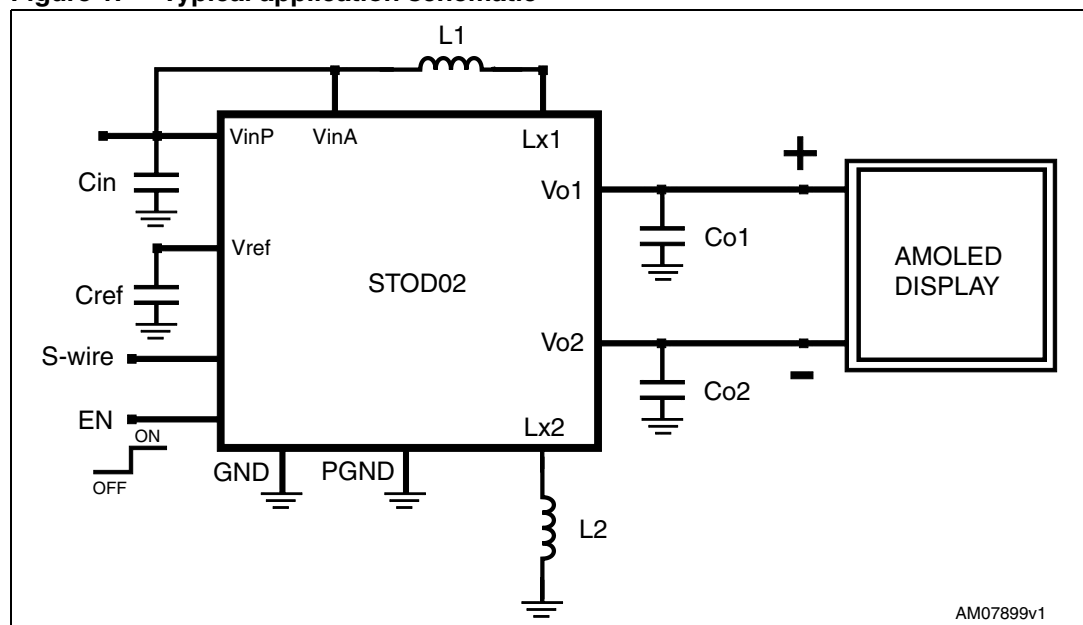

Contents

- 1 Package description and order codes 3**

- 2 External component selection 4**
 - 2.1 Input and output capacitor selection 4
 - 2.2 Inductor selection 4

- 3 Demonstration board BOM and schematic 5**

- 4 Connector description 6**

- 5 PCB layout 7**
 - 5.1 Demonstration board PCB layout 7

- 6 Efficiency results 9**

- 7 Revision history 10**

1 Package description and order codes

The dual DC-DC converter STOD02 is housed in a 12-pin DFN (3 x 3 mm.). The device is available in 2 different thicknesses: 0.8 mm and 0.6 mm. [Table 1.](#) shows the related commercial order codes.

Table 1. Order codes

| Order code | Package | Packaging | Marking |
|------------|-------------------------|---------------------|---------|
| STOD02PUR | DFN12L (3 x 3 x 0.8 mm) | 3000 parts per reel | D02D |
| STOD02TPUR | DFN12L (3 x 3 x 0.6 mm) | 3000 parts per reel | 02T |

2 External component selection

2.1 Input and output capacitor selection

The use of ceramic capacitors with low ESR as input and output capacitors is recommended. It is also recommended to use 4.7 μF / 6.3 V as a minimum value for the input and output capacitors and 1 μF / 6.3 V as the optimal value for the reference capacitor, in order to achieve good device stability.

Note: See recommended components in [Table 2](#).

2.2 Inductor selection

In order to fully benefit from the compact solution offered by the STOD02, a very thin inductor with a low DC series winding resistance is recommended for this application.

The maximum current of the inductor must be taken into consideration in order to avoid saturation of the core. The STOD02 automatically limits the maximum current in the inductor to 0.9 A for the step-up stage and 1.1 A for the inverting stage.

Suggested inductance values are in the range between 4.7 μH and 6.8 μH .

Note: See recommended components in [Table 2](#).

3 Demonstration board BOM and schematic

Table 2 shows the components used in the STOD02 demonstration board, however the STOD02 operation is not limited to the use of these components.

Table 2. BOM list

| Component | Manufacturer | Part number | Value | Size |
|-------------------|--------------|-------------------|-------------|--------------------|
| L+ | MARUWA | CXFU 0208 – 4R7 | 4.7 μ H | 3.3 x 3.3 x 0.8 mm |
| L- | MARUWA | CXFU 0208 – 4R7 | 4.7 μ H | 3.3 x 3.3 x 0.8 mm |
| C _{IN} | MURATA | GRM188R60J475KE19 | 4.7 μ F | 0603 |
| C _{OUT+} | MURATA | GRM188R60J475KE19 | 4.7 μ F | 0603 |
| C _{OUT-} | MURATA | GRM188R60J475KE19 | 4.7 μ F | 0603 |
| C _{ref} | MURATA | GRM188F51A105ZA01 | 1.0 μ F | 0402 |

Figure 2. Demonstration board schematic

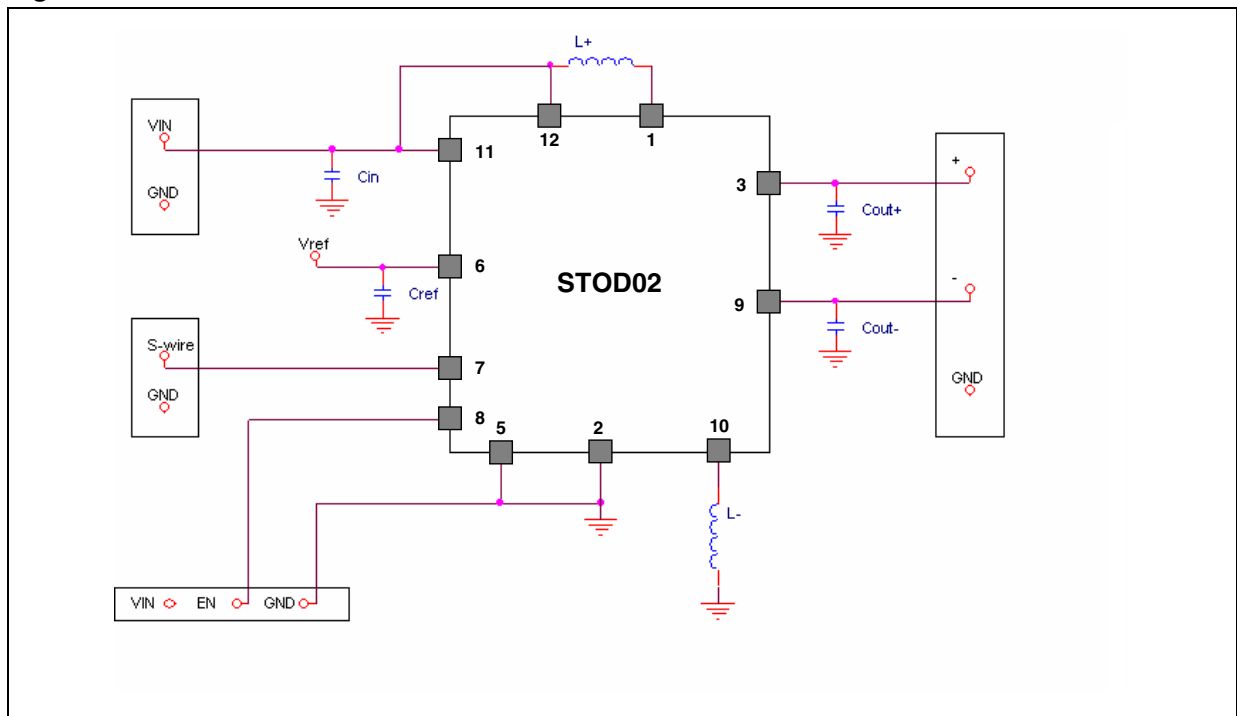

4 Connector description

Table 3. Connector description

| Connector | Function | Notes |
|-----------|-------------------------------|---|
| Input | Power input voltage | This is the input power source. The STOD02 is specifically designed to work with low impedance power sources, such as a battery. In the case where a lab power source is used with long wires, a 470 μ F capacitor connected to the input connector must be used to bypass the power input source. |
| Output | Positive and negative outputs | The positive and negative voltages are available through this connector. The cumulative differential voltage is supplied between + and – connectors. A real AMOLED panel must be connected between them. The single positive and negative voltages are supplied at +/GND and -/GND for testing purposes. |
| S-wire | Connection for S-wire pin | This connector allows access to the S-wire pin. The negative voltage of the STOD02 is set at - 4.9 V as a default. By applying a special command to the S-wire pin the negative voltage can be changed to different values. See the STOD02 datasheet for a detailed description of this function. Short the S-wire pin to GND if this function is not used. |
| Enable | Connection for Enable pin | This connector allows the turning-on/off of the device. A short between En/V _{IN} enables the device, while a short between En/Gnd disables the device. |

5 PCB layout

The STOD02 is a switching device in which the PCB must be designed in line with switched supplies design rules. The power tracks (or wires in the demo board) must be as short as possible and of suitable width, because of the peak currents involved. It is recommended to use a 2-layer PCB to attain the best performance. All external components must be placed as close as possible to the STOD02. All high-energy switched loops should be as small as possible to reduce EMI. Efficient cooling is needed and may be done by using a dedicated copper area on the PCB.

All the Power ground tracks coming from C_{IN} , C_{OUT+} , C_{OUT-} must be placed as close as possible to the PGND pin in order to create a good GND route.

5.1 Demonstration board PCB layout

Figure 3. Top layer

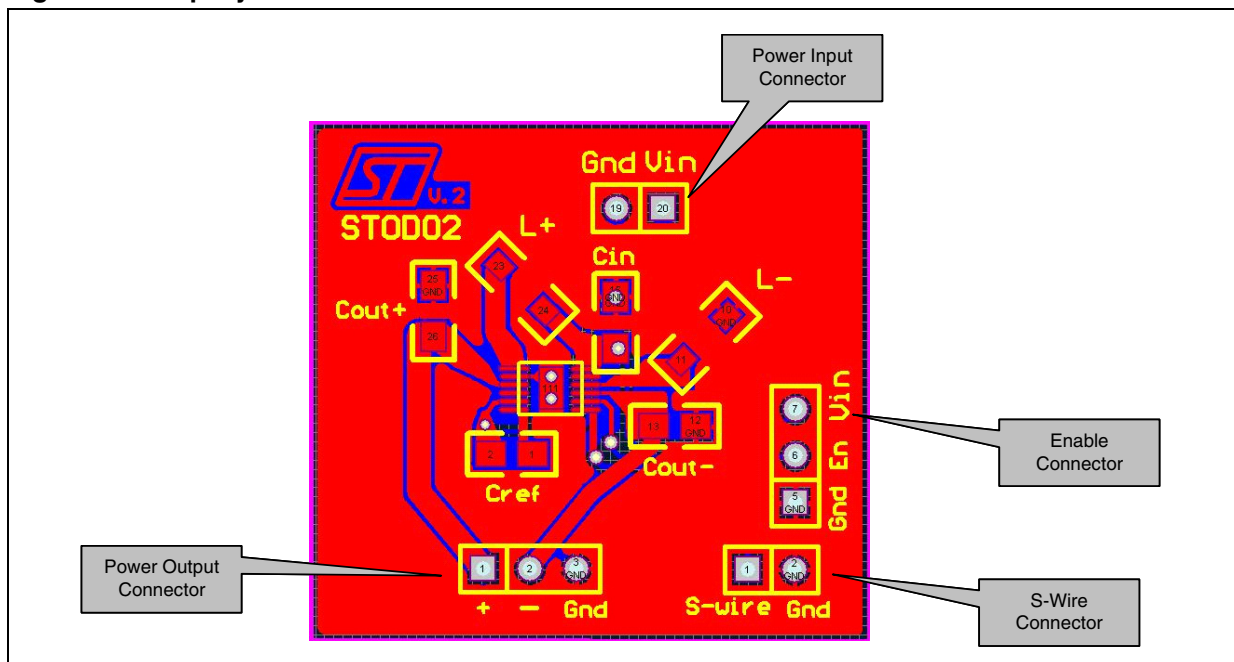
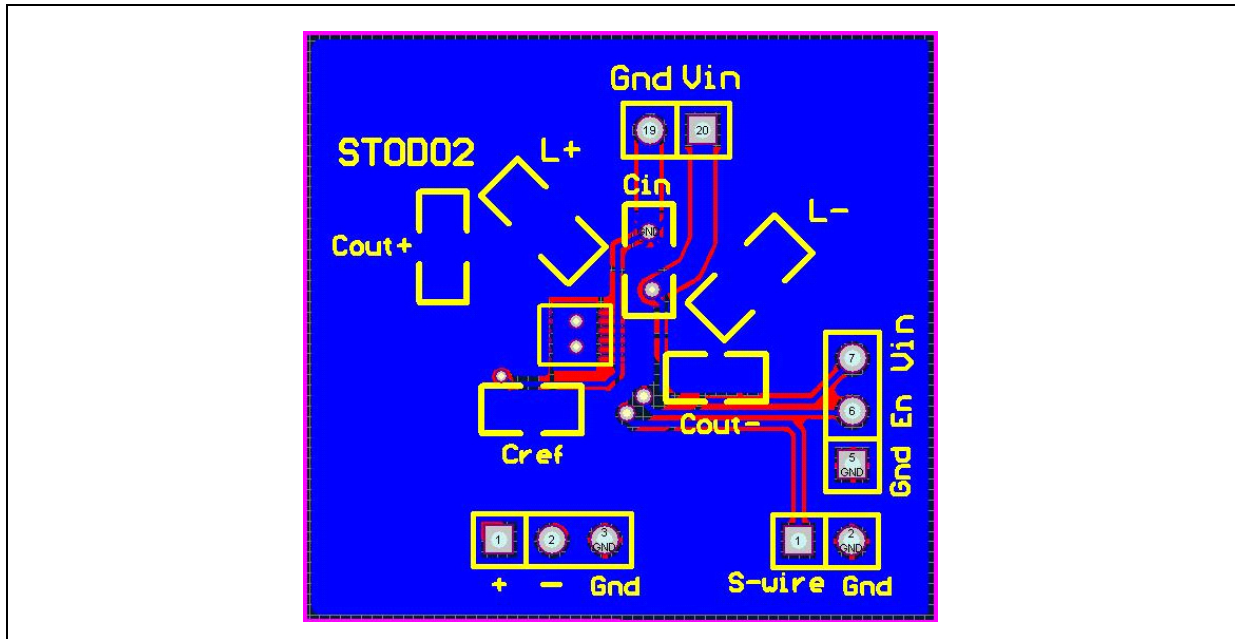

Figure 4. Bottom layer



6 Efficiency results

External components as per [Table 2](#)

Figure 5. Efficiency vs. I_{OUT}

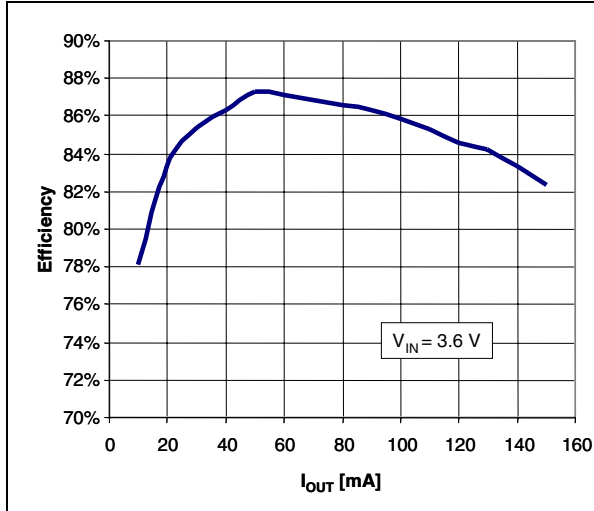
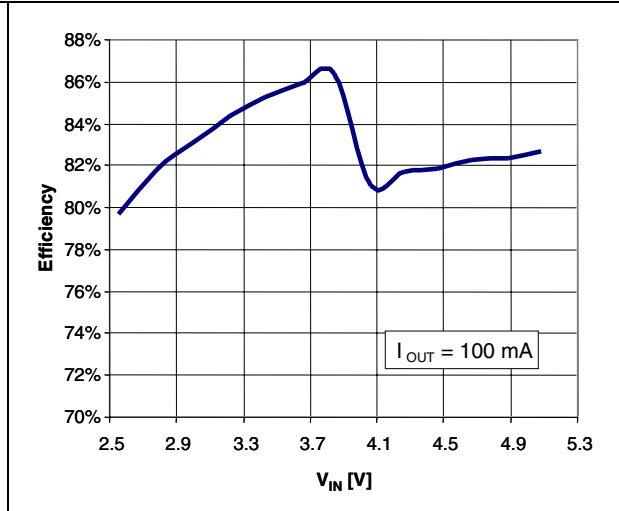

Figure 6. Efficiency vs. V_{IN}



7 Revision history

Table 4. Document revision history

| Date | Revision | Changes |
|-------------|----------|------------------|
| 30-Nov-2010 | 1 | Initial release. |

Please Read Carefully:

Information in this document is provided solely in connection with ST products. STMicroelectronics NV and its subsidiaries ("ST") reserve the right to make changes, corrections, modifications or improvements, to this document, and the products and services described herein at any time, without notice.

All ST products are sold pursuant to ST's terms and conditions of sale.

Purchasers are solely responsible for the choice, selection and use of the ST products and services described herein, and ST assumes no liability whatsoever relating to the choice, selection or use of the ST products and services described herein.

No license, express or implied, by estoppel or otherwise, to any intellectual property rights is granted under this document. If any part of this document refers to any third party products or services it shall not be deemed a license grant by ST for the use of such third party products or services, or any intellectual property contained therein or considered as a warranty covering the use in any manner whatsoever of such third party products or services or any intellectual property contained therein.

UNLESS OTHERWISE SET FORTH IN ST'S TERMS AND CONDITIONS OF SALE ST DISCLAIMS ANY EXPRESS OR IMPLIED WARRANTY WITH RESPECT TO THE USE AND/OR SALE OF ST PRODUCTS INCLUDING WITHOUT LIMITATION IMPLIED WARRANTIES OF MERCHANTABILITY, FITNESS FOR A PARTICULAR PURPOSE (AND THEIR EQUIVALENTS UNDER THE LAWS OF ANY JURISDICTION), OR INFRINGEMENT OF ANY PATENT, COPYRIGHT OR OTHER INTELLECTUAL PROPERTY RIGHT.

UNLESS EXPRESSLY APPROVED IN WRITING BY AN AUTHORIZED ST REPRESENTATIVE, ST PRODUCTS ARE NOT RECOMMENDED, AUTHORIZED OR WARRANTED FOR USE IN MILITARY, AIR CRAFT, SPACE, LIFE SAVING, OR LIFE SUSTAINING APPLICATIONS, NOR IN PRODUCTS OR SYSTEMS WHERE FAILURE OR MALFUNCTION MAY RESULT IN PERSONAL INJURY, DEATH, OR SEVERE PROPERTY OR ENVIRONMENTAL DAMAGE. ST PRODUCTS WHICH ARE NOT SPECIFIED AS "AUTOMOTIVE GRADE" MAY ONLY BE USED IN AUTOMOTIVE APPLICATIONS AT USER'S OWN RISK.

Resale of ST products with provisions different from the statements and/or technical features set forth in this document shall immediately void any warranty granted by ST for the ST product or service described herein and shall not create or extend in any manner whatsoever, any liability of ST.

ST and the ST logo are trademarks or registered trademarks of ST in various countries.

Information in this document supersedes and replaces all information previously supplied.

The ST logo is a registered trademark of STMicroelectronics. All other names are the property of their respective owners.

© 2010 STMicroelectronics - All rights reserved

STMicroelectronics group of companies

Australia - Belgium - Brazil - Canada - China - Czech Republic - Finland - France - Germany - Hong Kong - India - Israel - Italy - Japan - Malaysia - Malta - Morocco - Philippines - Singapore - Spain - Sweden - Switzerland - United Kingdom - United States of America

www.st.com

