



# Contents

- 1 Overview ..... 3**
  - 1.1 Features ..... 3
  - 1.2 Software example ..... 3
  - 1.3 Order code ..... 3
  - 1.4 Hardware layout ..... 4
  
- 2 Configuration ..... 6**
  - 2.1 Power supply ..... 6
  - 2.2 Boot options ..... 6
  - 2.3 Reset sources ..... 7
  - 2.4 CAN (controller area network) ..... 7
  - 2.5 RS-232C ..... 7
  - 2.6 SD/MMC card ..... 7
  - 2.7 USB-OTG (USB ON-THE-GO) ..... 7
  - 2.8 LM75 temperature sensor ..... 8
  - 2.9 Debug interface ..... 8
  - 2.10 Ethernet ..... 8
  - 2.11 Clock sources ..... 9
  - 2.12 Connectors ..... 9
    - 2.12.1 RS-232C connector (CN7) ..... 9
    - 2.12.2 Power connectors (CN1 and CN9) ..... 9
    - 2.12.3 Extension connector (CN3) ..... 10
  
- 3 I/O assignments ..... 11**
  
- 4 Schematics ..... 14**
  
- 5 Revision history ..... 26**

# 1 Overview

## 1.1 Features

- 72 MHz STM32F107 Cortex™-M3 based microcontroller with:
  - 256 Kbytes of Flash
  - 64 Kbytes of SRAM
- 10/100 Ethernet connector
- USB-OTG full-speed connector
- RS-232C connector
- CAN interface connected to pin headers
- SD/MMC socket
- STLM75 temperature sensor
- 3 user LEDs (red, yellow and green)
- Reset button
- Free I/O ports connector (pin headers)
- Prototyping area
- On-board J-Link SWD for debugging
- Powered by J-Link USB connector or 5V external power supply on screw terminal
- RoHS compliant

## 1.2 Software example

- Example #1 described in the  $\mu$ C/OS-III book is preloaded in the board's Flash memory showing the LD1, DL2 & DL3 blinking. For more information on this demonstration example, please refer to Chapter 3 of the  $\mu$ C/OS-III book .

## 1.3 Order code

- To order the  $\mu$ C/OS-III book and the STM32-MICRIUM evaluation board, use the order code STM32CMICOS-EVAL.

### 1.4 Hardware layout

The STM32-MICRIUM evaluation board is designed around the STM32F107VCT in a 100-pin TQFP package.

Figure 2 illustrates the connection between the STM32F107VCT and peripherals (USB-OTG, Ethernet, SD/MMC, RS-232, CAN temperature sensor).

Figure 3 helps you to locate these features on the actual evaluation board.

Figure 2. STM32-MICRIUM evaluation board hardware block diagram

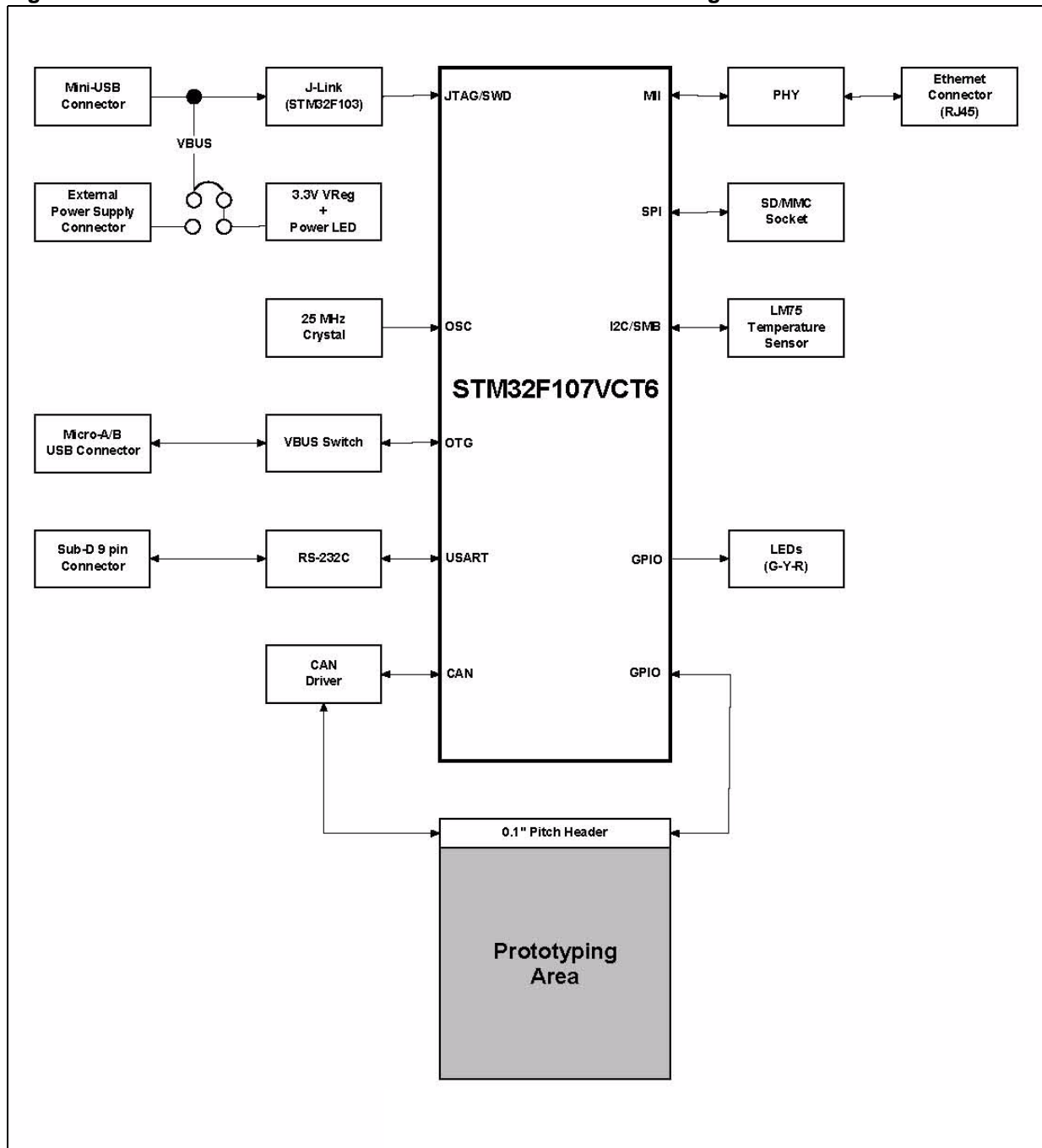
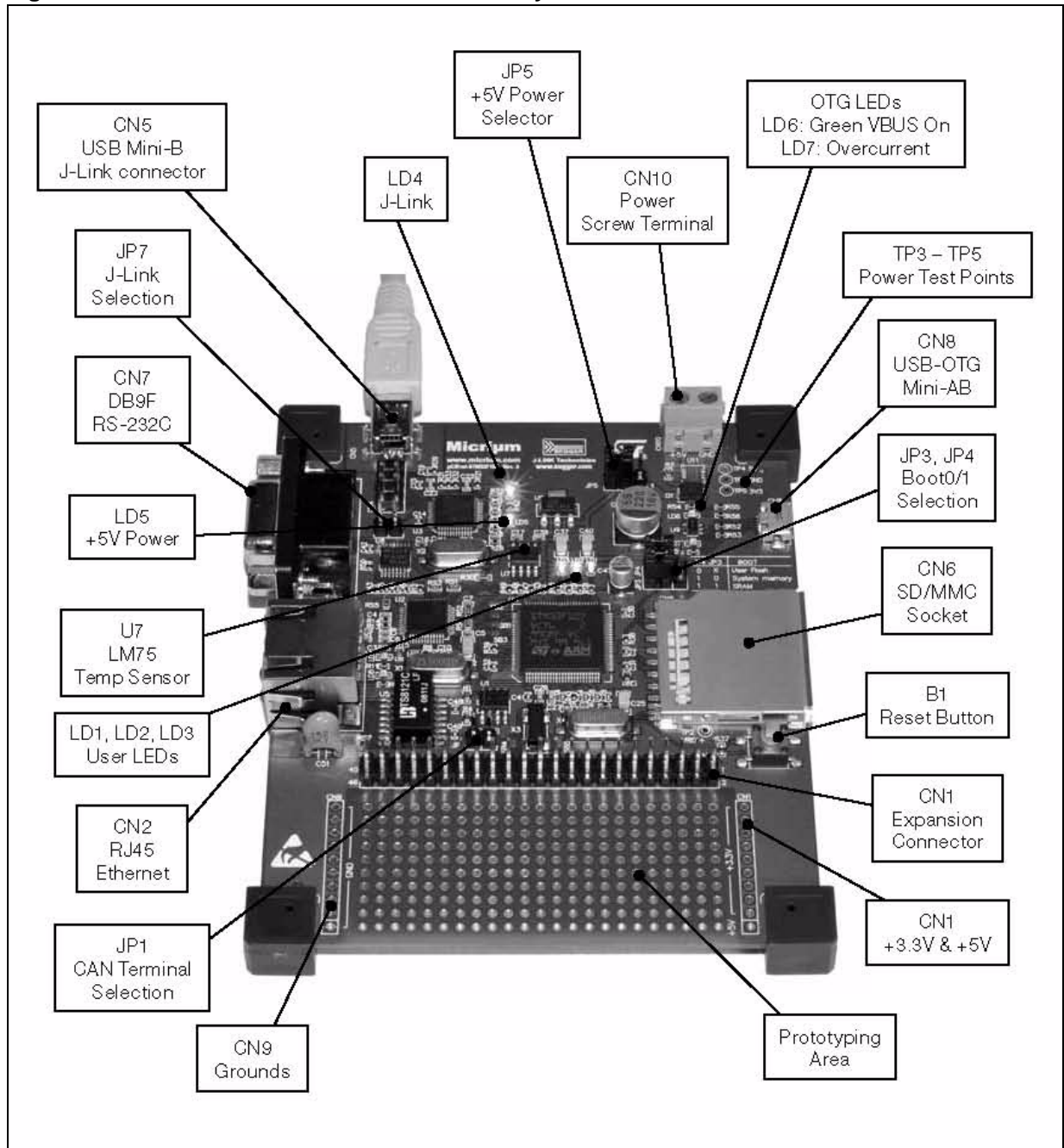

Figure 3. STM32-MICRIUM evaluation board layout



## 2 Configuration

### 2.1 Power supply

The STM32-MICRIUM evaluation board is powered by a 5V DC power supply. It is configured via JP5 to use the following power supply sources:

- 5V DC power adapter connected to CN10, the power screw terminal on the board.
- 5V VBUS power (500 mA limitation from CN5), the mini-B USB of embedded J-Link.

**Table 1. STM32-MICRIUM evaluation board power supply jumper**

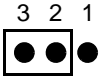
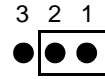
Jumper	Description	Switch configuration
JP5	The board is powered by VBUS of the embedded J-Link input CN5 when JP5 is set as shown on the right: (Default setting).	
	The board is powered by 5V DC input CN10 when JP5 is set as shown on the right:	

- Note:*
- 1 The board cannot be powered by VBUS on CN8 when USB-OTG is used as a USB device.
  - 2 The LED LD5 is lit when the STM32CMICOS-EVAL board is powered by the 5V correctly.
  - 3 Three test points TP4 (5V), TP3 (GND), and TP2 (3.3V) are available on the top right of the board to check power supply.

### 2.2 Boot options

The boot option is configured by setting switch JP3 (BOOT1) and JP4 (BOOT0). The STM32-MICRIUM evaluation board can boot from:

- Embedded user Flash.
- System memory.
- Embedded SRAM for debugging.

**Table 2. STM32-MICRIUM evaluation board boot options jumpers**

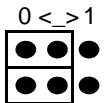
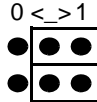
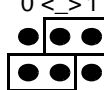
Jumper	Description	Configuration
JP3 & JP4	STM32-MICRIUM evaluation board boots from user Flash when JP4 is set as shown to the right. JP3 is not relevant in this configuration. (Default setting).	
	STM32-MICRIUM evaluation board boots from embedded SRAM when JP3 and JP4 are set as shown to the right.	
	STM32-MICRIUM evaluation board boots from system memory when JP3 and JP4 are set as shown to the right.	

## 2.3 Reset sources

The reset signal of the STM32-MICRIUM evaluation board is active low. The reset source may come from:

- Reset button B1 in bottom right of the board.
- Embedded J-Link.
- Extension connector CN3 pin 45 (pin header).

## 2.4 CAN (controller area network)

The STM32-MICRIUM evaluation board supports one channel of CAN2.0A/B-compliant CAN bus communication based on a 3.3V CAN transceiver. The CAN transceiver (U1) is configured for high-speed mode. The CAN bus is available on extension connector CN3 pin 28 (CAN\_L) and pin 30 (CAN\_H). The CAN interface is connected to CAN1 remapped (PD0, PD1) of the STM32F107VCT. The CAN terminal (120 ohm), available on the board, can be connected on the bus by the jumper JP1.

**Table 3. STM32-MICRIUM evaluation board CAN related jumper**

Jumper	Description
JP1	CAN terminal resistor is enabled when JP1 is fitted. Default setting: Not fitted.

## 2.5 RS-232C

The RS-232 communication with hardware flow control is supported by CN7 (a 9-pin D-type RS-232 connector) and the transceiver U8, which is connected to USART2 remapped on PD3 to PD6 of STM32F107VCT on STM32-MICRIUM evaluation board.

## 2.6 SD/MMC card

An SD/MMC card (Secure Digital/Multi-Media Card) connector (CN6) is available on the board, but the card is not provided by default with the product. The SD/MMC card is connected to SPI1 of STM32F107VCT (PA5 to PA7 without remap) with chip select on PA8 and card detection on PE6.

## 2.7 USB-OTG (USB ON-THE-GO)

The STM32-MICRIUM evaluation board supports USB-OTG full-speed communication via a USB Micro-AB connector (CN8) and USB power switch (U9) connected to VBUS. The evaluation board cannot be powered by this USB connector.

The green LED LD6 turns on when the power switch (U9) is ON, which corresponds to USB-host mode. In this case, the 5V VBUS is provided by the board to a USB device connected on CN8. The red LED LD7 turns on when an over-current condition is detected.

## 2.8 LM75 temperature sensor

A 10-bit temperature sensor, STLM75M2E (U7), is connected to the I2C1 bus of the STM32F107VCT without remap (PB5 to PB7).

## 2.9 Debug interface

An embedded J-Link (JTAG/SWD development tool from IAR) is available on the STM32-MICRIUM evaluation board as the default debugger/programmer interface. The mini-B USB connector CN5 is used to interface the embedded J-Link (U3) using the IAR Embedded Workbench for ARM toolchain. The SWD port of the embedded J-Link is directly connected to the STM32F107VCT debug port and optionally, through solder bridges, to all other JTAG signals, as detailed in [Table 5](#).

Other debugger/programmer hardware can be supported by the JTAG/SWD signals available on extension connector CN3. The debug tool used can be selected by the jumper JP2, as mentioned in [Table 4](#).

**Table 4. STM32-MICRIUM evaluation board J-Link related jumper**

Jumper	Description
JP2	Open: embedded J-Link is selected as debugger/programmer tool (Default setting).
	Closed: external debugger/programmer tool connected on CN3 is used.

**Table 5. STM32-MICRIUM evaluation board J-TAG solder bridges**

Jumper	Description
SB1	Open: J-Link TDO/SWO is not connected to the TDO of the STM32F107VCT. J-Link supports SWD communication only.
	Closed: J-Link TDO/SWO is connected to the TDO of the STM32F107VCT. J-Link supports JTAG and SWD communication (Default setting).
SB2	Open: J-Link TDI is not connected to the TDI of the STM32F107VCT. J-Link supports SWD communication only.
	Closed: J-Link TDI is connected to the TDI of the STM32F107VCT. J-Link supports JTAG and SWD communication (Default setting).
SB3	Open: J-Link TRST is not connected to the TRST of the STM32F107VCT. J-Link supports SWD communication only.
	Closed: J-Link TRST is connected to the TRST of the STM32F107VCT. J-Link supports JTAG and SWD communication (Default setting).

## 2.10 Ethernet

The STM32-MICRIUM evaluation board supports a 10/100 Ethernet communication interface with a 'PHY' (DP83848CVV, U2) and integrated RJ45 connector (CN2). MII interface mode is also supported.

The 25 MHz Ethernet clock is provided by crystal X1 connected to the PHY.

*Note:* Test point TP1 can be used to check the PHY clock frequency.



## 2.11 Clock sources

Two clock sources are available on the STM32-MICRIUM evaluation board for the STM32F107VCT, and also include an embedded RTC:

- X3, 32.768 KHz crystal for embedded RTC connected to PC14, PC15.
- X2, 25 MHz crystal for the STM32F107VCT microcontroller.

The PC14 and PC15 are available on extension connector CN3 depending on SB4 and SB5 configuration as mentioned in [Table 6](#).

**Table 6. STM32-MICRIUM evaluation board 32 KHz crystal X3 solder bridges**

Jumper	Description
SB4	Open: PC14 is connected to 32 KHz crystal (Default setting). Closed: P14 is connected to extension connector CN3.
SB5	Open: PC15 is connected to 32 KHz crystal (Default setting). Closed: P15 is connected to extension connector CN3.

## 2.12 Connectors

### 2.12.1 RS-232C connector (CN7)

**Figure 4. STM32CMICOS-EVAL DB-9F RS-232C CN6 with ISP support (front view)**

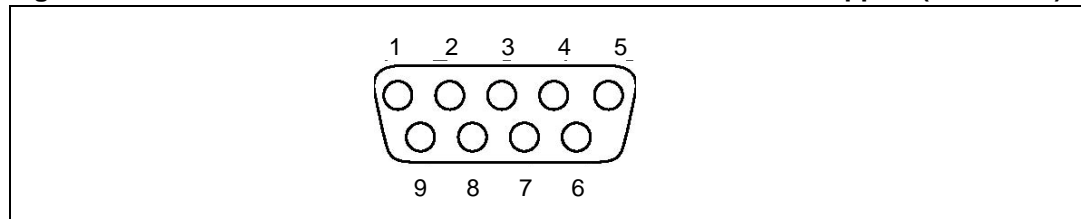

**Table 7. RS-232C connector CN6 with ISP support**

Pin number	Description	Pin number	Description
1	NC	6	NC
2	RS232_TXD (PD5)	7	RS232_CTS (PD3)
3	RS232_RXD (PD6)	8	RS232_RTS (PD4)
4	NC	9	NC
5	GND		

### 2.12.2 Power connectors (CN1 and CN9)

The nine pins of connector CN9 on the left side of the wrapping area are connected to the board's ground.

The eight higher pins of connector CN8 are connected to the 3.3V power, and the lower pin is connected to the 5V power of the board.

### 2.12.3 Extension connector (CN3)

**Table 8. CN3 pinout**

Description	Pin name	Pin number of CN3		Pin name	Description
IO port	PA4	1	2	PE3	IO port
IO port	PB0	3	4	PE4	IO port
IO port	PB1	5	6	PB3	IO port or TDO (SB1)
IO port	PB9	7	8	PB4	IO port or TRST (SB3)
IO port	PB14	9	10	PE7	IO port
IO port	PB15	11	12	PE8	IO port
IO port	PC0	13	14	PE9	IO port
IO port	PC4	15	16	PE10	IO port
IO port	PC5	17	18	PE11	IO port
IO port	PC6	19	20	P12	IO port
IO port	PC7	21	22	PE13	IO port
IO port	PC8	23	24	PE14	IO port
IO port	PC9	25	26	PE15	IO port
IO port	PC10	27	28	CAN_L	CAN bus L
IO port	PC11	29	30	CAN_H	CAN bus H
IO port	PC12	31	32	PD6	IO port
IO port	PC13	33	34	PD5	IO port
IO port (SB4)	PC14	35	36	PD4	IO port
IO port (SB5)	PC15	37	38	PD3	IO port
IO port	PD2	39	40	PA15	IO port or TDI (SB2)
IO port	PD7	41	42	PE2	IO port
IO port	PE0	43	44	PA13	IO port or TMS
Board reset	RESET	45	46	PA14	IO port or TCK

*Note:* (SBx) means that a corresponding solder bridge must be set to enable the signal on the connector.

### 3 I/O assignments

**Table 9. I/O assignments**

Pin No.	Pin name	STM32-MICRIUM evaluation board processor I/O assignments
1	PE2	IO PORT PE2
2	PE3	IO PORT PE3
3	PE4	IO PORT PE4
4	PE5	MII_INT
5	PE6	SDCard_Detection
6	VBAT	
7	PC13-ANTI_TAMP	IO PORT PC13
8	PC14-OSC32_IN	OSC32K or IO PORT PC14
9	PC15-OSC32_OUT	OSC32K or IO PORT PC15
10	VSS_5	
11	VDD_5	
12	OSC_IN	
13	OSC_OUT	
14	NRST	RESET
15	PC0	IO PORT PC0
16	PC1	ETHER_MDC
17	PC2	ETHER_TXD2
18	PC3	ETHER_TX_CLK
19	VSSA	
20	VREF	
21	VREF+	
22	VDDA	
23	PA0-WKUP	ETHER_CRS
24	PA1	ETHER_RX_CLK
25	PA2	ETHER_MDIO
26	PA3	ETHER_COL
27	VSS_4	
28	VDD_4	
29	PA4	IO PORT PA4
30	PA5	SPI_SCK_MMC
31	PA6	SPI_MISO_MMC
32	PA7	SPI_MOSI_MMC

Table 9. I/O assignments (continued)

Pin No.	Pin name	STM32-MICRIUM evaluation board processor I/O assignments
33	PC4	IO PORT PC4
34	PC5	IO PORT PC5
35	PB0	IO PORT PB0
36	PB1	IO PORT PB1
37	PB2	BOOT1
38	PE7	IO PORT PE7
39	PE8	IO PORT PE8
40	PE9	IO PORT PE9
41	PE10	IO PORT PE10
42	PE11	IO PORT PE11
43	PE12	IO PORT PE12
44	PE13	IO PORT PE13
45	PE14	IO PORT PE14
46	PE15	IO PORT PE15
47	PB10	ETHER_RX_ER
48	PB11	ETHER_TX_EN
49	VSS_1	
50	VDD_1	
51	PB12	ETHER_TXD0
52	PB13	ETHER_TXD1
53	PB14	IO PORT PB14
54	PB15	IO PORT PB15
55	PD8	ETHER_RX_DV
56	PD9	ETHER_RXD0
57	PD10	ETHER_RXD1
58	PD11	ETHER_RXD2
59	PD12	ETHER_RXD3
60	PD13	LED0
61	PD14	LED1
62	PD15	LED2
63	PC6	IO PORT PC6
64	PC7	IO PORT PC7
65	PC8	IO PORT PC8
66	PC9	IO PORT PC9
67	PA8	SPI_CS_MMC

**Table 9. I/O assignments (continued)**

Pin No.	Pin name	STM32-MICRIUM evaluation board processor I/O assignments
68	PA9	VBUS
69	PA10	ID
70	PA11	DM
71	PA12	DP
72	PA13	Debug TMS
73	NC	
74	VSS_2	
75	VDD_2	
76	PA14	Debug TCK
77	PA15	Debug TDI
78	PC10	IO PORT PC10
79	PC11	IO PORT PC11
80	PC12	IO PORT PC12
81	PD0	CAN_RX
82	PD1	CAN_TX
83	PD2	IO PORT PD2
84	PD3	USART_CTS
85	PD4	USART_RTS
86	PD5	USART_TX
87	PD6	USART_RX
88	PD7	IO PORT PD7
89	PB3	Debug TDO
90	PB4	Debug TRST
91	PB5	INT_Temperature
92	PB6	I2C_SCL_Temperature
93	PB7	I2C_SDA_Temperature
94	BOOT0	BOOT0
95	PB8	ETHER_TXD3
96	PB9	IO PORT PB9
97	PE0	IO PORT PE0
98	PE1	USB_PowerSwitchOn
99	VSS_3	
100	VDD_3	

## 4 Schematics

This section provides the design schematics for the STM32-MICRIUM evaluation board key features, to help you implement these features in your applications.

The following schematics are provided:

- [Figure 5: Block diagram on page 15](#)
- [Figure 6: STM32F107VCT6 on page 16](#)
- [Figure 7: CAN on page 17](#)
- [Figure 8: Ethernet on page 18](#)
- [Figure 9: Extension connector on page 19](#)
- [Figure 10: SD card on page 20](#)
- [Figure 11: Temperature sensor on page 21](#)
- [Figure 12: RS-232 on page 22](#)
- [Figure 13: USB-OTG-FS on page 23](#)
- [Figure 14: J-Link on page 24](#)
- [Figure 15: Power on page 25](#)



Figure 5. Block diagram

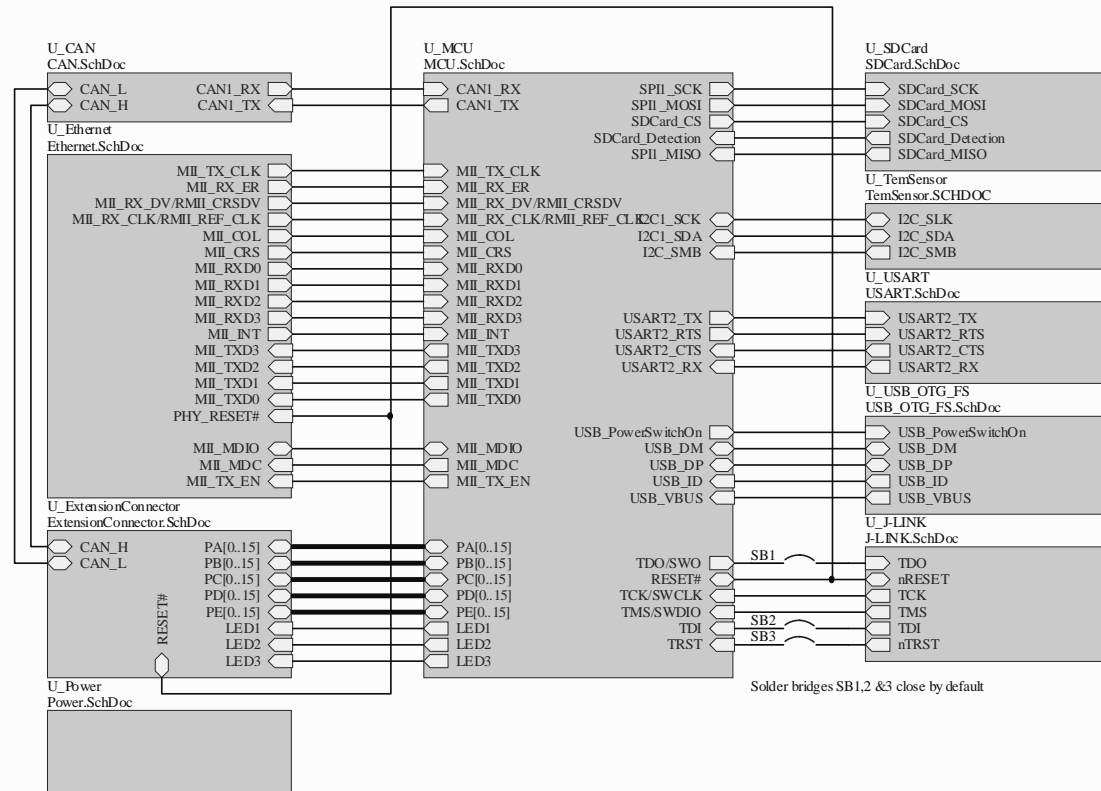

Solder bridges SB1,2 & SB3 close by default

Note 1: only default setting of SB1,2 & SB3 was updated to be close from Version B.1 to B.2.

**STMicroelectronics**

Title: uC/eval-STM32F107

Number: MB834 | Rev: B.2(PCB.SCH) | Date: 10/9/2009 | Sheet 1 of 11



Figure 6. STM32F107VCT6

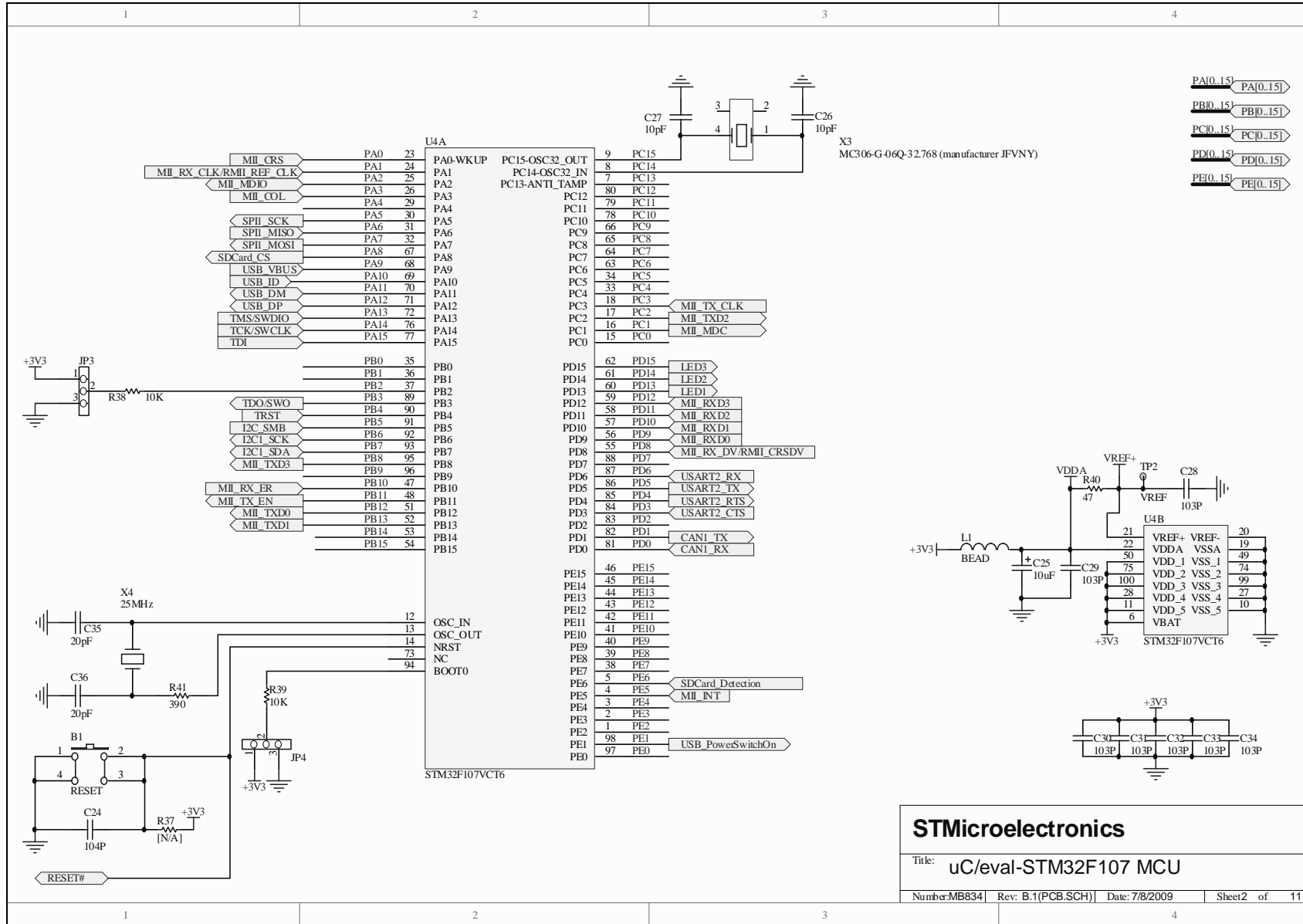

Doc ID 16173 Rev 2

16/27

STM32-MICRUM

Schematics

**STMicroelectronics**

Title: uC/eval-STM32F107 MCU

Number:MB834 Rev: B.1(PCB.SCH) Date: 7/8/2009 Sheet2 of 11





Figure 7. CAN

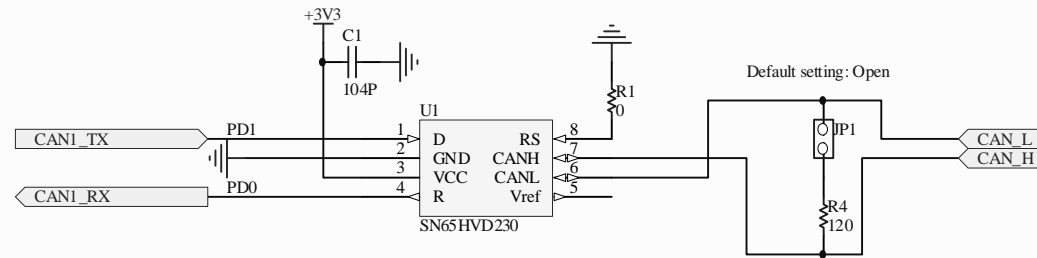

Doc ID 16173 Rev 2

17/27

**STMicroelectronics**

Title: uC/eval-STM32F107 CAN

Number:MB834 Rev: B.2(PCB.SCH) Date: 10/9/2009



Figure 8. Ethernet

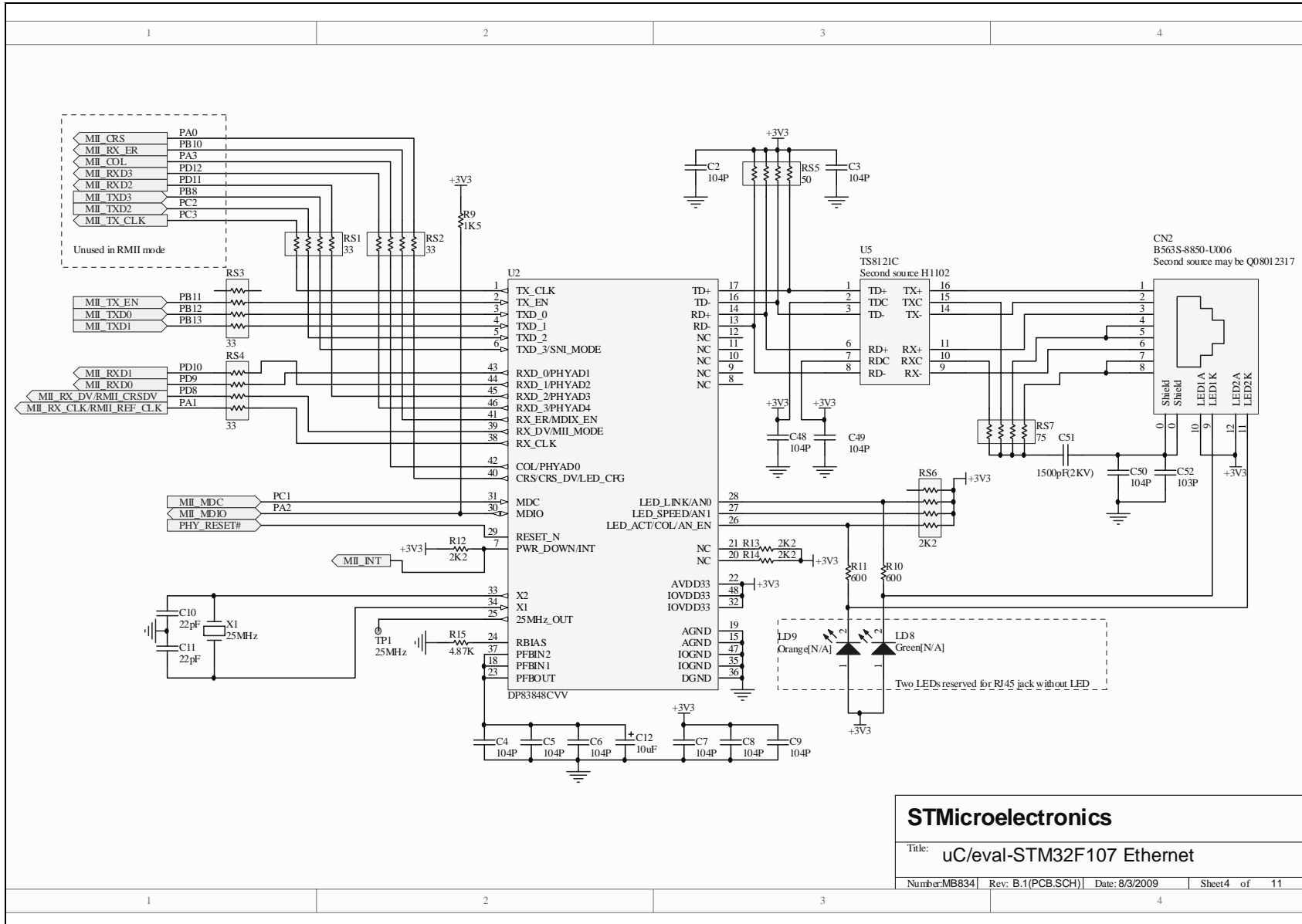

<b>STMicroelectronics</b>			
Title: uC/eval-STM32F107 Ethernet			
Number: MB834	Rev: B.1(PCB.SCH)	Date: 8/3/2009	Sheet 4 of 11

Doc ID 16173 Rev 2

18/27

STM32-MICRUM

Schematics



Figure 9. Extension connector

Doc ID 16173 Rev 2

19/27

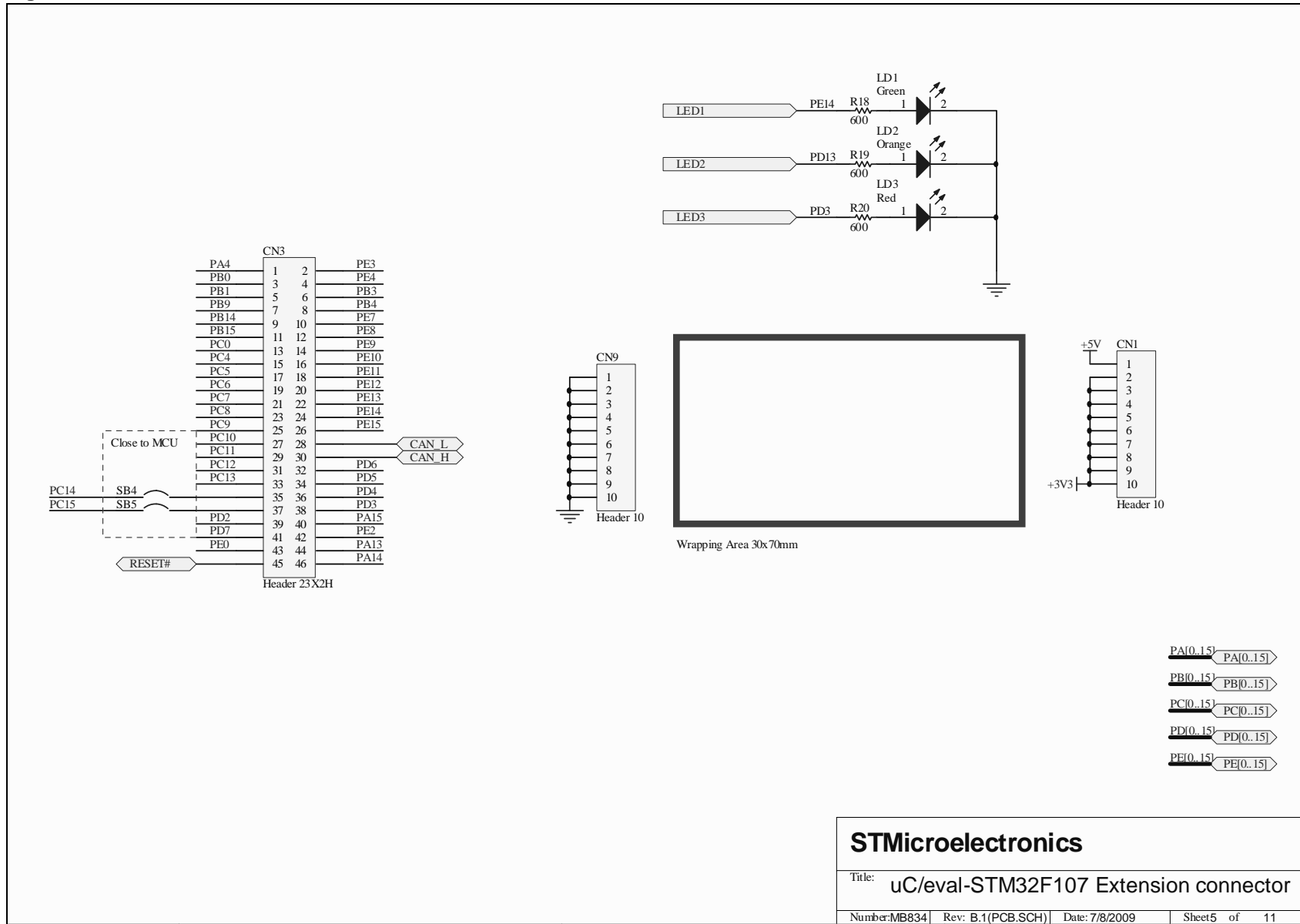
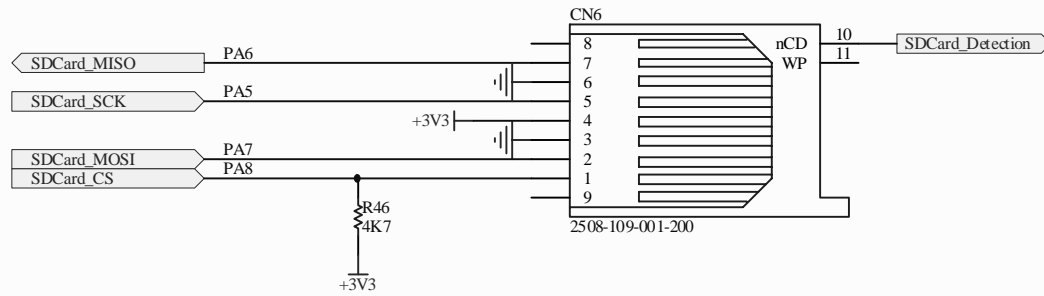



Figure 10. SD card



Doc ID 16173 Rev 2

20/27

**STMicroelectronics**

Title: uC/eval-STM32F107 SD card

Number: MB834 | Rev: B.1(PCB.SCH) | Date: 7/8/2009



Figure 11. Temperature sensor

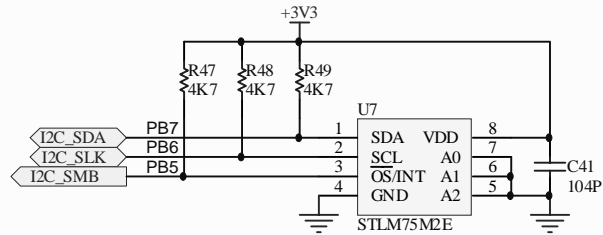

Doc ID 16173 Rev 2

21/27

<b>STMicroelectronics</b>			
Title: uC/eval-STM32F107 TemperatureSensor			
Number:MB834	Rev: B.1(PCB.SCH)	Date: 7/8/2009	Sheet7 of 11



Figure 12. RS-232

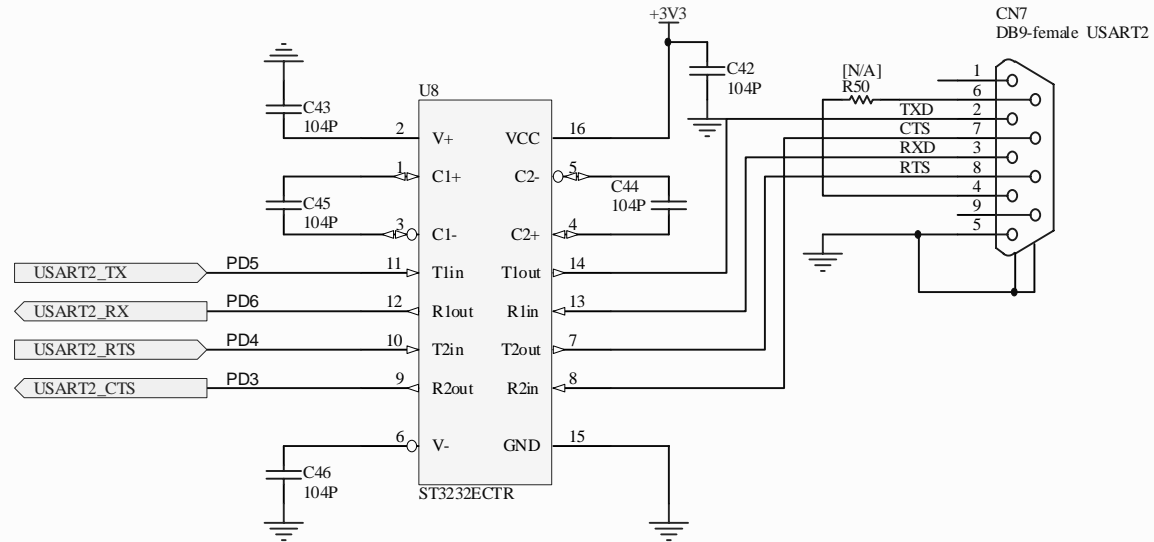

Doc ID 16173 Rev 2

22/27

**STMicroelectronics**

Title: uC/eval-STM32F107 RS232

Number:MB834 | Rev: B.1(PCB.SCH) | Date: 7/8/2009



Figure 13. USB-OTG-FS

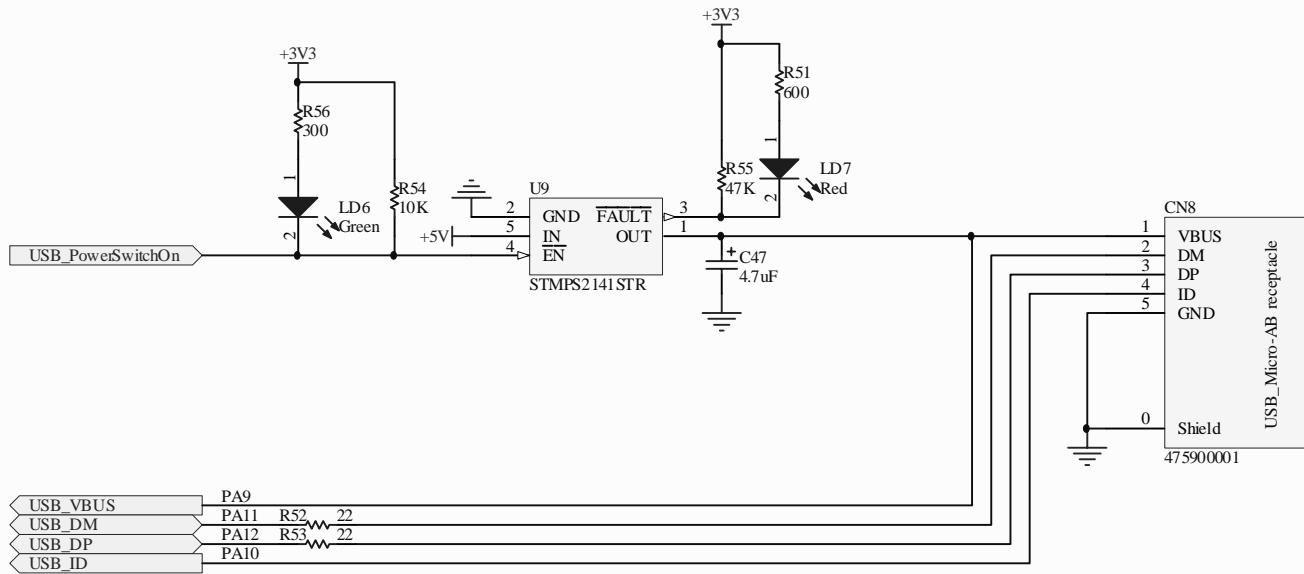

Doc ID 16173 Rev 2

23/27

**STMicroelectronics**

Title: uC/eval-STM32F107 USB\_OTG\_FS

Number:MB834 | Rev: B.1(PCB.SCH) | Date: 7/8/2009 | Sheet9 of



Figure 14. J-Link

Doc ID 16173 Rev 2

24/27

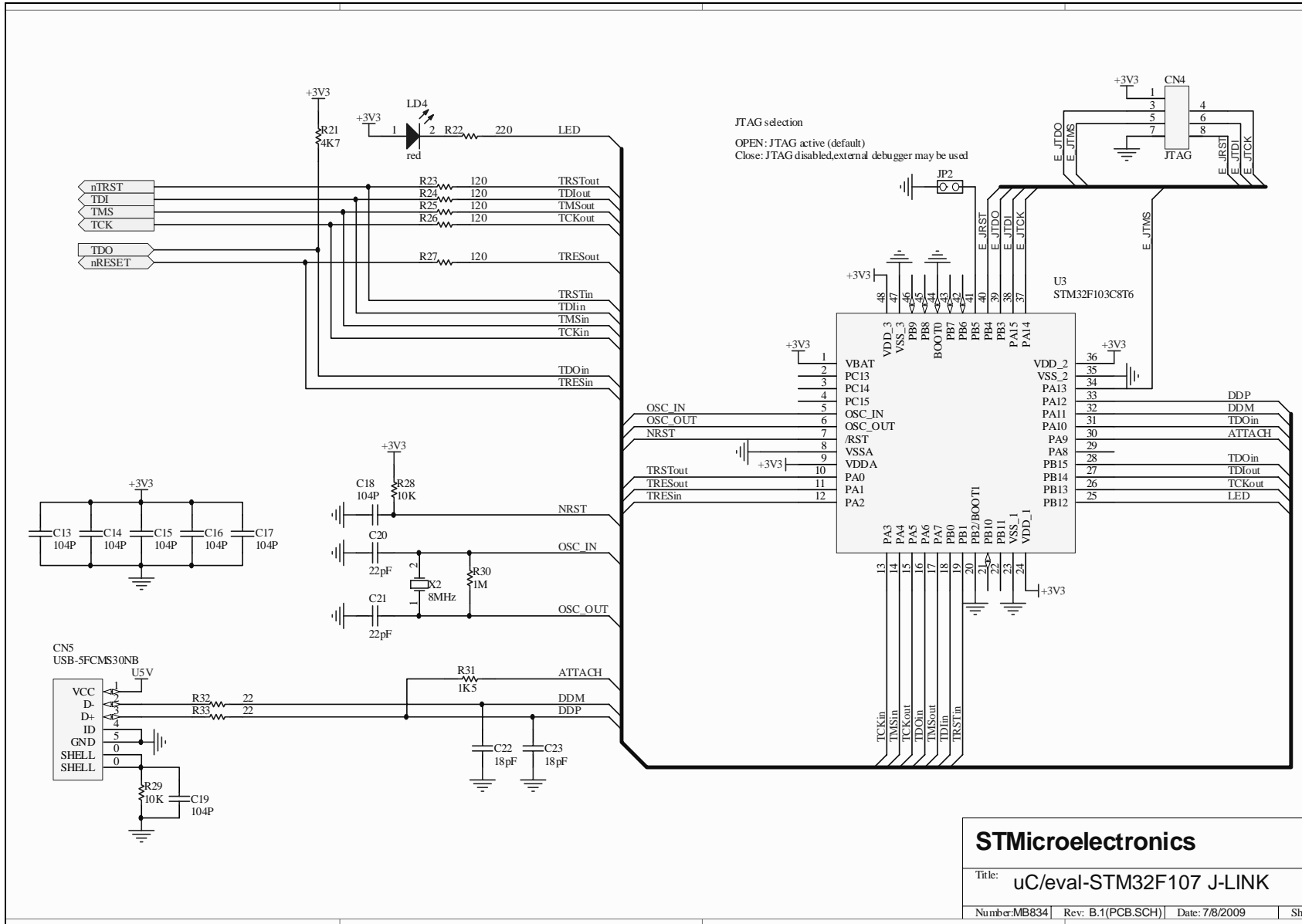

<b>STMicroelectronics</b>			
Title: uC/eval-STM32F107 J-LINK			
Number: MB834	Rev: B.1(PCB.SCH)	Date: 7/8/2009	Sheet: 1/1

STM32-MICRUM

Schematics





Figure 15. Power

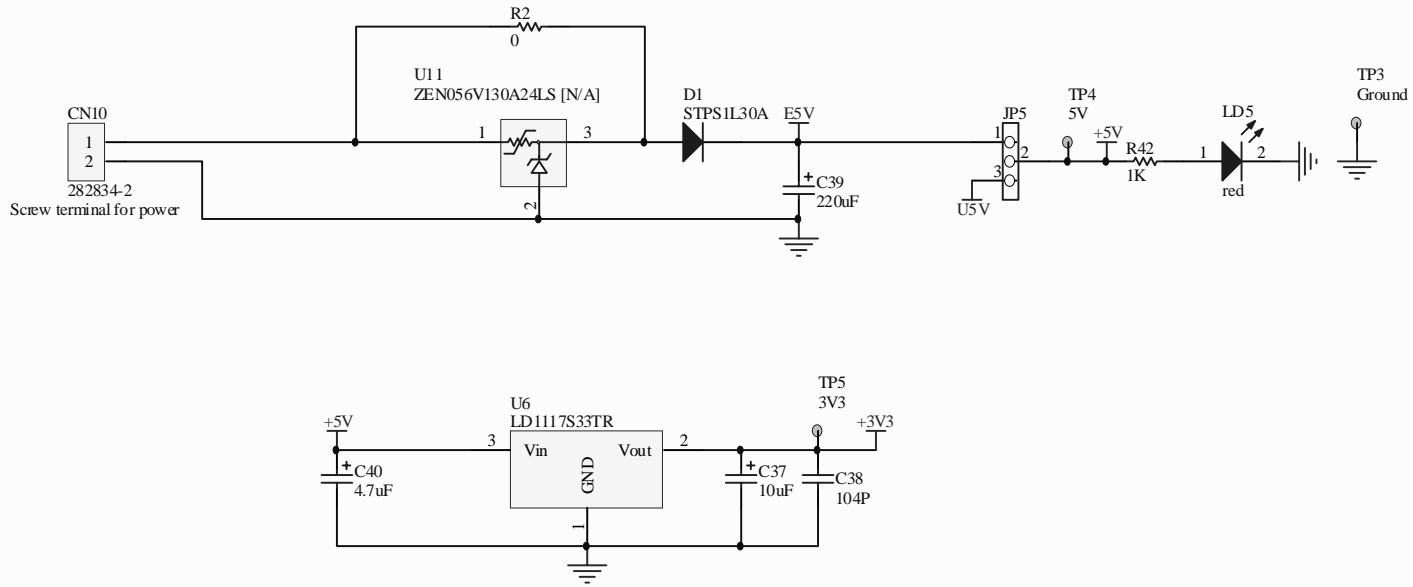

Doc ID 16173 Rev 2

25/27

**STMicroelectronics**

Title: uC/eval-STM32F107 Power

Number: MB834 | Rev: B.1(PCB.SCH) | Date: 7/8/2009 | She

## 5 Revision history

Table 10. Document revision history

Date	Revision	Changes
14-Sept-2009	1	Initial release.
22-Oct-2009	2	<a href="#">Table 5</a> default settings changed. <a href="#">Section 1.2</a> added, <a href="#">Section 1.3</a> changed.

**Please Read Carefully:**

Information in this document is provided solely in connection with ST products. STMicroelectronics NV and its subsidiaries ("ST") reserve the right to make changes, corrections, modifications or improvements, to this document, and the products and services described herein at any time, without notice.

All ST products are sold pursuant to ST's terms and conditions of sale.

Purchasers are solely responsible for the choice, selection and use of the ST products and services described herein, and ST assumes no liability whatsoever relating to the choice, selection or use of the ST products and services described herein.

No license, express or implied, by estoppel or otherwise, to any intellectual property rights is granted under this document. If any part of this document refers to any third party products or services it shall not be deemed a license grant by ST for the use of such third party products or services, or any intellectual property contained therein or considered as a warranty covering the use in any manner whatsoever of such third party products or services or any intellectual property contained therein.

**UNLESS OTHERWISE SET FORTH IN ST'S TERMS AND CONDITIONS OF SALE ST DISCLAIMS ANY EXPRESS OR IMPLIED WARRANTY WITH RESPECT TO THE USE AND/OR SALE OF ST PRODUCTS INCLUDING WITHOUT LIMITATION IMPLIED WARRANTIES OF MERCHANTABILITY, FITNESS FOR A PARTICULAR PURPOSE (AND THEIR EQUIVALENTS UNDER THE LAWS OF ANY JURISDICTION), OR INFRINGEMENT OF ANY PATENT, COPYRIGHT OR OTHER INTELLECTUAL PROPERTY RIGHT.**

**UNLESS EXPRESSLY APPROVED IN WRITING BY AN AUTHORIZED ST REPRESENTATIVE, ST PRODUCTS ARE NOT RECOMMENDED, AUTHORIZED OR WARRANTED FOR USE IN MILITARY, AIR CRAFT, SPACE, LIFE SAVING, OR LIFE SUSTAINING APPLICATIONS, NOR IN PRODUCTS OR SYSTEMS WHERE FAILURE OR MALFUNCTION MAY RESULT IN PERSONAL INJURY, DEATH, OR SEVERE PROPERTY OR ENVIRONMENTAL DAMAGE. ST PRODUCTS WHICH ARE NOT SPECIFIED AS "AUTOMOTIVE GRADE" MAY ONLY BE USED IN AUTOMOTIVE APPLICATIONS AT USER'S OWN RISK.**

Resale of ST products with provisions different from the statements and/or technical features set forth in this document shall immediately void any warranty granted by ST for the ST product or service described herein and shall not create or extend in any manner whatsoever, any liability of ST.

ST and the ST logo are trademarks or registered trademarks of ST in various countries.

Information in this document supersedes and replaces all information previously supplied.

The ST logo is a registered trademark of STMicroelectronics. All other names are the property of their respective owners.

© 2009 STMicroelectronics - All rights reserved

STMicroelectronics group of companies

Australia - Belgium - Brazil - Canada - China - Czech Republic - Finland - France - Germany - Hong Kong - India - Israel - Italy - Japan - Malaysia - Malta - Morocco - Philippines - Singapore - Spain - Sweden - Switzerland - United Kingdom - United States of America

[www.st.com](http://www.st.com)