



Smart monitoring system STEVAL-IFS014V1 and STEVAL-IFS015V1, based on the STM32x

Introduction

This document explains the functioning of the "smart monitoring system" and also serves as a quick reference manual to operate the system. The smart monitoring system works on ZigBee[®] wireless technology and measures temperature, humidity and light intensity of 9 remote and different locations simultaneously. The system also demonstrates the wireless control of home appliances and can serve as a basis for many new systems.

The objective of this demonstration board is to design a complete system which demonstrates the effectiveness of low data rate wireless solutions from ST in automating various measurements for weather parameters. This system can be further interfaced to take an appropriate action based on the parameters being monitored. The system can very easily be modified to control various household appliances by suitable additional hardware. This system uses various devices, the most relevant are the STM32x (microcontroller), SPZB260 (ZigBee[®] device), LIS331DLH (MEMS), STMPE811 (touchscreen controller), STLM20 (temperature sensor) and various power supply components along with the battery charger. The system has been designed taking future expandability into consideration.

The system can be powered up using:

- External power supply
- 3.7 V Li-Ion battery

To summarize, the key features of the system are:

- Wireless network
- Monitoring of weather parameters (temperature, humidity, light intensity)
- Wireless light control application
- Node movement and simultaneous node movement detection
- Various weather warning configurations and alarm messages
- TFT display with touchscreen
- Real-time clock along with alarm configurations
- Data logging for more than one year
- GUI for data reading, saving and analysis using graphs
- Power management system
- Battery charging capability
- Embedded in-circuit programming capability using JTAG

Contents

- 1 System features 7**
 - 1.1 Wireless network 7
 - 1.2 Single node movement detection 8
 - 1.3 Simultaneous node movement detection 8
 - 1.4 Weather alarm conditions 8
 - 1.5 Light control application 9
 - 1.6 Data logging 9
 - 1.7 User interface 9
 - 1.7.1 TFT display 9
 - 1.7.2 Touchscreen 9
 - 1.7.3 Buzzer 9
 - 1.7.4 LEDs 10
 - 1.7.5 Menu 10
 - 1.8 Graphical user interface 10
 - 1.9 Clock and alarm feature 10
 - 1.10 Powering the system 10

- 2 Getting started 11**
 - 2.1 System requirements 11
 - 2.2 System content 11
 - 2.3 Hardware installation 11
 - 2.4 Powering up the system 15

- 3 System operation 16**
 - 3.1 Starting up the system 16
 - 3.2 Establishing the network 17
 - 3.3 Seeing the parameters of a specific node 18
 - 3.4 Data logging 19
 - 3.5 Alarm system 20
 - 3.5.1 Threshold crossing of weather parameters 20
 - 3.5.2 Node movement 20
 - 3.5.3 Simultaneous node movement 21

	3.5.4	Low battery and battery recovery	22
	3.5.5	Clock alarm	22
4		Description of the STEVAL-IFS014V1 (smart monitoring station) ...	23
	4.1	Components of the sensor data screen	23
	4.2	Dedicated symbols for important actions	23
	4.3	Menu	24
	4.3.1	USB mode	25
	4.3.2	About	25
	4.3.3	Switching the lamp on or off (light application)	25
	4.3.4	Setting the system time	25
	4.3.5	Setting the clock alarm	26
	4.3.6	Setting the various warning alarms	27
	4.3.7	No-display mode (power saving)	27
	4.3.8	System restore	27
	4.4	Meaning of navigational icons	28
5		Description of the STEVAL-IFS015V1 (smart monitoring node)	29
	5.1	Components of default display screen	29
	5.2	Other messages	29
	5.3	JTAG connectivity	30
6		Additional setup information	31
	6.1	Complete example of menu navigation of STEVAL-IFS014V1	31
	6.2	Factory default values	34
	6.3	LEDs	35
	6.4	Battery connection	35
	6.4.1	Battery connection - STEVAL-IFS014V1	36
	6.4.2	Battery connection - STEVAL-IFS015V1	40
7		Schematics and bill of material	46
	7.1	Schematic and bill of material of STEVAL-IFS014V1	46
	7.2	Schematic and bill of material of STEVAL-IFS015V1	57
8		Revision history	65

List of tables

Table 1.	Parameters of ZigBee network for smart monitoring system	7
Table 2.	Bill of material of STEVAL-IFS014V1	51
Table 3.	Bill of material of STEVAL-IFS015V1	60
Table 4.	Document revision history	65

List of figures

Figure 1.	Smart monitoring station (STEVAL-IFS014V1) - front view	12
Figure 2.	Smart monitoring station (STEVAL-IFS014V1) - side view	12
Figure 3.	Smart monitoring station (STEVAL-IFS014V1) - back view	13
Figure 4.	Smart monitoring node (STEVAL-IFS015V1) - front view	13
Figure 5.	Smart monitoring node (STEVAL-IFS015V1) - side view	14
Figure 6.	Smart monitoring node (STEVAL-IFS015V1) - back view	14
Figure 7.	Welcome screens of STEVAL-IFS014V1	16
Figure 8.	Initial data screen	16
Figure 9.	Newly joined node	17
Figure 10.	Assign node number	17
Figure 11.	Sensor data screen with one active node	18
Figure 12.	Sensor data screen with more than one active node	18
Figure 13.	Selecting the node to see the parameters	19
Figure 14.	Warning messages	20
Figure 15.	Node movement - alarm message	21
Figure 16.	Simultaneous node movement of nodes 2, 4 and 5 caused simultaneous movement detection	21
Figure 17.	Sensor data screen	23
Figure 18.	Dedicated icons for various actions	24
Figure 19.	Menu details	24
Figure 20.	Configured clock alarm indication	26
Figure 21.	Details of data screen of STEVAL-IFS015V1	29
Figure 22.	Various other message screens of STEVAL-IFS015V1	30
Figure 23.	Selecting "MENU" using stylus	31
Figure 24.	Menu	31
Figure 25.	"SETTINGS" menu	32
Figure 26.	"CLOCK" menu	32
Figure 27.	"SYSTEM TIME" - 1	32
Figure 28.	"SYSTEM TIME" - 2	33
Figure 29.	"SYSTEM TIME" - 3	33
Figure 30.	"SET SYSTEM TIME" - 4	34
Figure 31.	"SET SYSTEM DATE"	34
Figure 32.	Dimensions of Li-Ion battery	35
Figure 33.	Back of STEVAL-IFS014V1 and screwdriver	36
Figure 34.	Removal of rubber pads	36
Figure 35.	Removal of screws	36
Figure 36.	Front of STEVAL-IFS014V1	37
Figure 37.	Opening the top cover	37
Figure 38.	Removing the cover of double-sided tape for battery placement	37
Figure 39.	Battery correctly placed	38
Figure 40.	Battery soldering	38
Figure 41.	Checking that the battery connection is correct	38
Figure 42.	Closing the top cover of the case	39
Figure 43.	Tightening the screws	39
Figure 44.	3 V coin-type CR2032 battery insertion for RTC power backup	40
Figure 45.	Back of STEVAL-IFS015V1 and screwdriver	40
Figure 46.	Removal of rubber pads	40
Figure 47.	Removal of screws	41

Figure 48.	Front of STEVAL-IFS015v1	41
Figure 49.	Removal of top cover of the case	41
Figure 50.	Removing the LCD	42
Figure 51.	Removing the cover of double-sided tape for battery placement	42
Figure 52.	Battery correctly placed	43
Figure 53.	Soldering the battery	43
Figure 54.	Checking that the battery connections are correct	43
Figure 55.	Applying the LCD and closing the top cover of case	44
Figure 56.	Tightening the case with screws	44
Figure 57.	Applying the rubber pads and STEVAL-IFS015V1 powered up with battery	45
Figure 58.	3 V coin-type CR2032 battery insertion for RTC power backup	45
Figure 59.	Sheet 1 of schematic of STEVAL-IFS014V1	46
Figure 60.	Sheet 2 of schematic of STEVAL-IFS014V1	47
Figure 61.	Sheet 3 of schematic of STEVAL-IFS014V1	48
Figure 62.	Sheet 4 of schematic of STEVAL-IFS014V1	49
Figure 63.	Sheet 5 of schematic of STEVAL-IFS014V1	50
Figure 64.	Sheet 1 of schematic of STEVAL-IFS015V1	57
Figure 65.	Sheet 2 of schematic of STEVAL-IFS015V1	58
Figure 66.	Sheet 3 of schematic of STEVAL-IFS015V1	59

1 System features

The "smart monitoring system" has been designed and developed to give the user a number of original features which make this system unique. The system is comprised of one smart monitoring station (STEVAL-IFS014V1) and a maximum of 8 different smart monitoring nodes (STEVAL-IFS015V1). The smart monitoring station and all the nodes make a wireless STAR network and all the nodes communicate with the smart station using ZigBee protocol. The smart station is a handheld device and can be carried by the user from one place to another. Also the size of the smart monitoring node is small and can be placed anywhere.

1.1 Wireless network

The smart monitoring station (STEVAL-IFS014V1) behaves as the coordinator of the ZigBee network and develops the network with a predefined network ID. The smart monitoring node (STEVAL-IFS015V1) can connect to the network as the end device. At any time the complete network can have a maximum of 8 nodes, and the weather parameters of all the nodes can be seen at the smart station along with those of the smart station.

The user can assign the application node numbers to the nodes which are connected during the system installation. This gives the user the freedom to assign a specific number to the connected node and place it anywhere.

Some of the key features of the wireless network are as follows:

- The system network supports one smart station (STEVAL-IFS014V1) and a maximum of 8 different nodes (STEVAL-IFS015V1)
- The user can assign the node number one at a time to the nodes being joined to the system
- Whenever a node is switched off or gets out of range, the system detects its absence and after ~1 minute, this node displays the message "node left"
- If a node is switched off or gets out of range and comes back, the system detects it and this node gets its previous user-assigned ID again without any intervention from the user
- If, in a working network, the power of the smart station is turned off and is powered up again, then after complete startup, the system itself recognizes all the previous active nodes of the system and re-assigns them the user-assigned numbers without any intervention from the user.

For the smart monitoring system, the following configurations of the ZigBee network have been used.

Table 1. Parameters of ZigBee network for smart monitoring system

Parameter	Value
Channel	26
Panid	0x01F0
Extended panid	{'H','W','M','S',' ','S','T','M'}
Power	3

Table 1. Parameters of ZigBee network for smart monitoring system (continued)

Parameter	Value
profile_ID	0xAAAA
Cluster_ID	0x0045

Note: Please note that these parameters have been chosen without any special consideration and can be changed later, but they should be the same for STEVAL-IFS014V1 and STEVAL-IFS015V1.

1.2 Single node movement detection

The system also detects movement or vibration of the active nodes in which case the buzzer sounds at the smart node and the smart station also receives this information. At the smart station an alarm buzzer sounds along with a message on the TFT display.

The system also calibrates the node movement into five different levels and stores this data along with the node number, severity level, date and time stamp. Node movement levels are defined in a range from 1 to 5 where 1 is the lowest intensity and 5 is the highest intensity.

1.3 Simultaneous node movement detection

The system has the capability to detect the simultaneous movement of all the connected nodes. The system detects simultaneous movement and sounds a buzzer alarm for the user and displays the warning message on the TFT display. This information is also stored in the data logging system along with the date and time stamp as “earthquake”.

Note: In the GUI of the system, the simultaneous movement of nodes is designated as “earthquake”.

Note: Simultaneous movement detection is possible only when the nodes have joined the system and are active, otherwise no earthquake detection is done as the smart station itself is a handheld system.

1.4 Weather alarm conditions

The system has the capability to configure the various maximum and minimum threshold values of the weather parameters of all the nodes connected to the system for the alarm conditions. Each node can be configured for different values.

Whenever any alarm condition of any of the smart node is reached, an alarm signal is given at the smart node as well as at the smart monitoring station.

The user can change the alarm conditions at any time through the smart monitoring station; there is no need to restart the system or node.

1.5 Light control application

The system demonstrates the application of wireless light control through which the user can control the LED lamp of any active smart node (D1 of STEVAI-IFS05V1) through the smart station.

This is just the demonstration of the wireless light control application and can be enlarged to a wider level to control any electrical appliance.

1.6 Data logging

The system has a data logging system which can store the data of more than one year (two values for each parameter of each node per day). The data logging system stores the maximum and minimum values of all the parameters of all the active smart nodes (STEVAL-IFS015V1) and smart station (STEVAL-IFS014V1) of one day along with the time stamp. The user can refer to the maximum and minimum value of any of the parameters of any of the nodes of any date and the time when it happened.

It also stores the node movement data of all the nodes along with the severity level, date and time stamp. So the user can view later which node was moved at which date and at what time.

Similar to the node movement data, the system also stores the earthquake (simultaneous movement of all active nodes) along with the severity level, date and time stamp.

Note: In the present system, the earthquake severity level is not calculated and has been set to minimum level 1.

1.7 User interface

The system has been provided with an interactive user interface with the features described in the following sections.

1.7.1 TFT display

The smart station (STEVAL-IFS014V1) has been provided with a 2.4" color TFT display on which all the data is displayed along with the various colored icons/symbols.

The smart node (STEVAI-IFS015V1) has been provided with a 122 X 32 graphical LCD display.

1.7.2 Touchscreen

The smart station (STEVAL-IFS014V1) has a touchscreen with which the user can navigate through the menu by just pressing the particular option displayed on the display. A beep produced by the buzzer confirms every screen touch.

1.7.3 Buzzer

Both the smart station and node have been provided with a buzzer which is used for the alarm conditions.

1.7.4 LEDs

Both the smart station and node have been provided with four status LEDs and one LED lamp (see [Section 6.3](#)).

1.7.5 Menu

Apart from all the hardware human interfaces, the system has been provided with a very good and user-friendly menu with which the user can perform various actions and settings.

1.8 Graphical user interface

The system is provided with a very useful graphical user interface to read and analyze the data logged in the system.

Some of the key features of the GUI are:

- All the logged data can be read from the system within 2-3 seconds
- The read data can be saved in the computer and can be analyzed at any time, if the system is connected to the computer or not
- The user can separate the data of the various nodes from any start and end date and can save the data in a .csv file format (.csv is a standard file format which stands for comma separated values. This file can be viewed using the software tool Microsoft office Excel.)
- The user can also plot the data in various graphs and can compare the data of the various nodes with each other and also for different dates of one node
- Graphs can be generated with various features to visualize the data in a proper way
- The user can save the graphs as pictures and even print the graphs.

1.9 Clock and alarm feature

The system has a built-in real-time clock. The user has the flexibility to set the clock time/date using the menu and the clock keeps running even when the system is not powered up. The user can also set the clock alarm for the same day.

1.10 Powering the system

The system has multiple ways of powering up with key features:

- Both the smart station (STEVAL-IFS014V1) and smart node (STEVAL-IFS015V1) can be powered up using the USB power supply (5 V) or 3.7 V Li-Ion battery
- The system has the capability to switch over from the external supply to battery backup and vice versa by itself
- When external USB power is available, the onboard battery starts charging and the system itself operates using external power
- The system has the capability to detect the low battery of the smart station (STEVAL-IFS014V1) as well as of the nodes (STEVAL-IFS015V1), and the information is displayed as an alarm and indicator of a low battery.

2 Getting started

2.1 System requirements

The system requires Li-Ion batteries (3.7 V, 1800 mAh) or suitable mini USB adaptors (5 V, 500 mA) for powering of the smart station (STEVAL-IFS014V1) and the node (STEVAL-IFS015V1).

2.2 System content

The complete system is comprised of the following:

- Hardware
 - STEVAL-IFS014V1 (smart monitoring station), 1 USB cable and 1 stylus
 - Three STEVAL-IFS015V1 devices (smart monitoring nodes)
- Software
 - GUI of the smart monitoring system
- Documentation
 - User manual (this document)

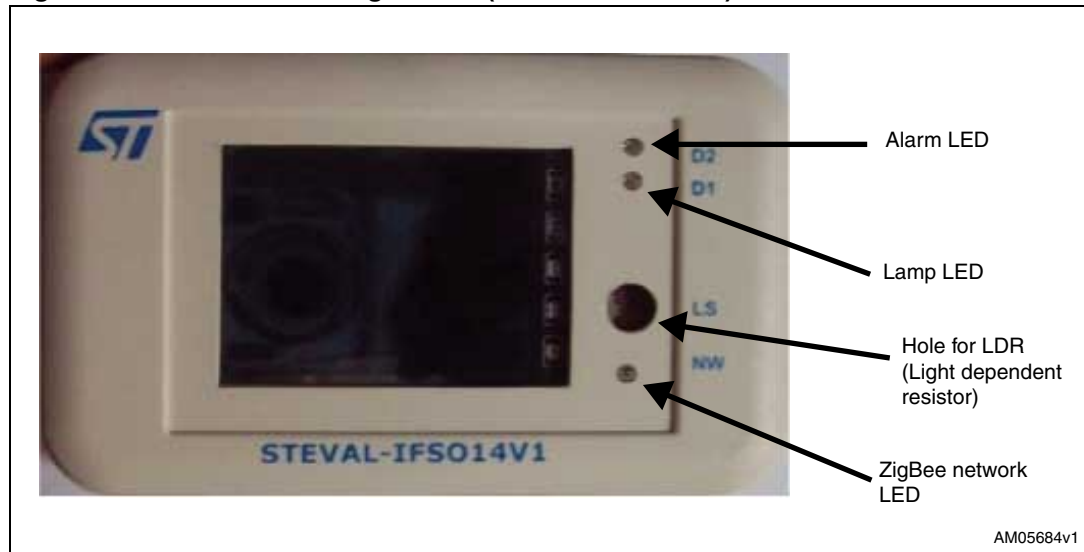
Note: The user should buy the STEVAL-IFS014V1 and STEVAL-IFS015V1 separately. These two are different entities and together they comprise the smart monitoring system.

Note: The smart monitoring system works as a standalone unit with either the STEVAL-IFS014V1 or STEVAL-IFS015V1. All the parameters are measured and displayed on the onboard display. Adding one node to the smart station allows one to evaluate the wireless features and the addition of two nodes would allow one to test the feature of simultaneous movement of the nodes. Two additional quantities of the STEVAL-IFS015V1 are recommended only to evaluate the complete system.

2.3 Hardware installation

Both the smart monitoring station (STEVAL-IFS014V1) and smart node (STEVAL-IFS015V1) can be powered by an external USB adaptor (5 V, 500 mA) or mini USB cable or by using the 3.7 V Li-Ion battery.

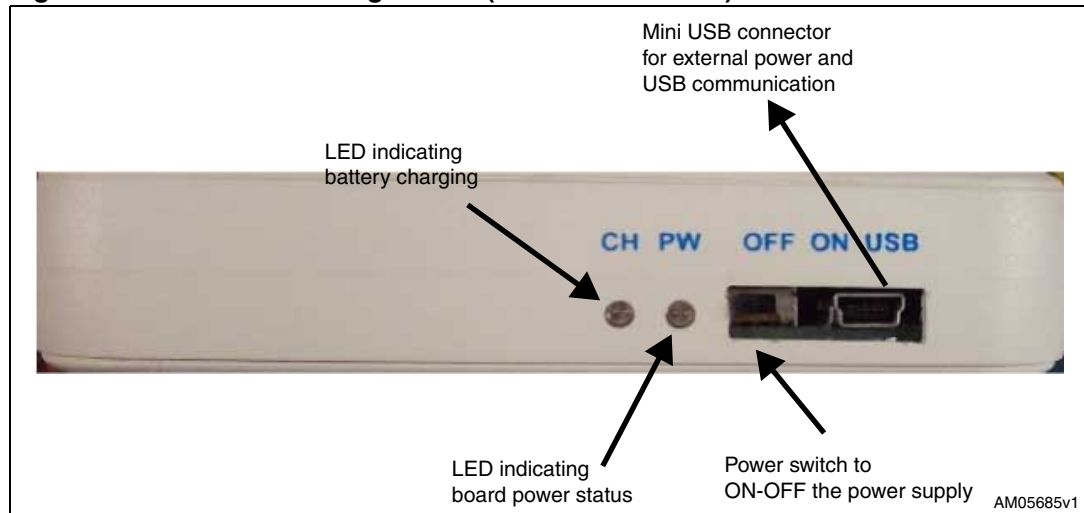
Figure 1. Smart monitoring station (STEVAL-IFS014V1) - front view



The major components present on the smart monitoring station (STEVAL-IFS014V1) - front view are (see *Figure 1*):

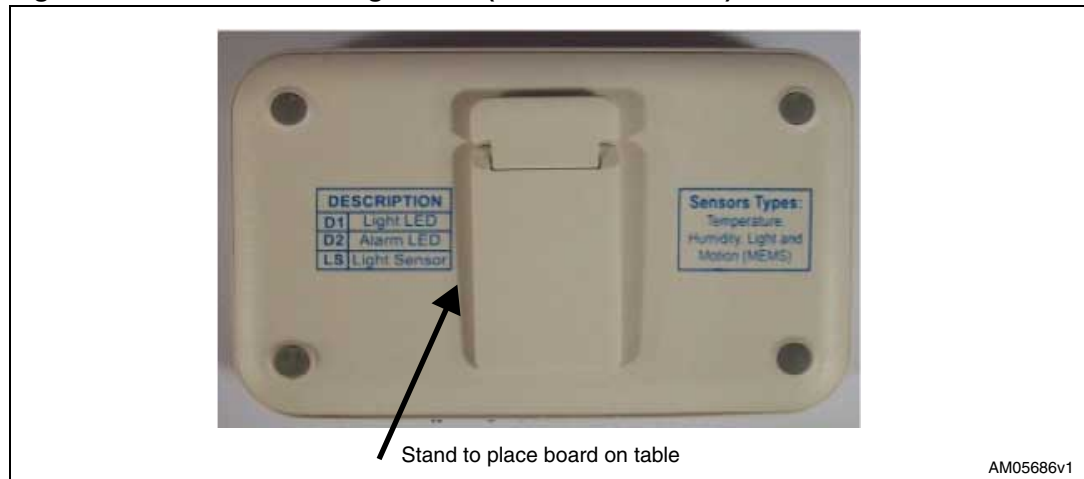
- TFT display having built-in touchscreen
- Light-dependent resistor (LDR) for measuring ambient light intensity
- D2 - LED indicator for alarm
- D1 - LED indicator for lamp
- NW - LED indicator for ZigBee® activity

Figure 2. Smart monitoring station (STEVAL-IFS014V1) - side view

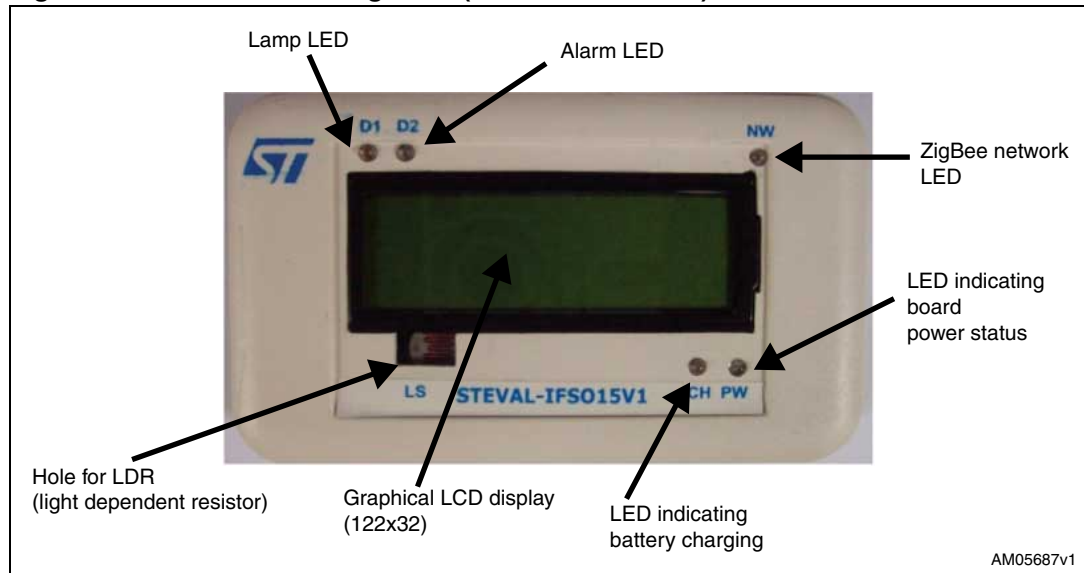


The major components present on the smart monitoring station (STEVAL-IFS014V1) - side view are (see *Figure 2*):

- USB - mini USB connector for power and USB connectivity
- Power switch - used for switching the board power on or off
- CH - LED indicator for battery charging
- PW - LED indicator for board power

Figure 3. Smart monitoring station (STEVAL-IFS014V1) - back view

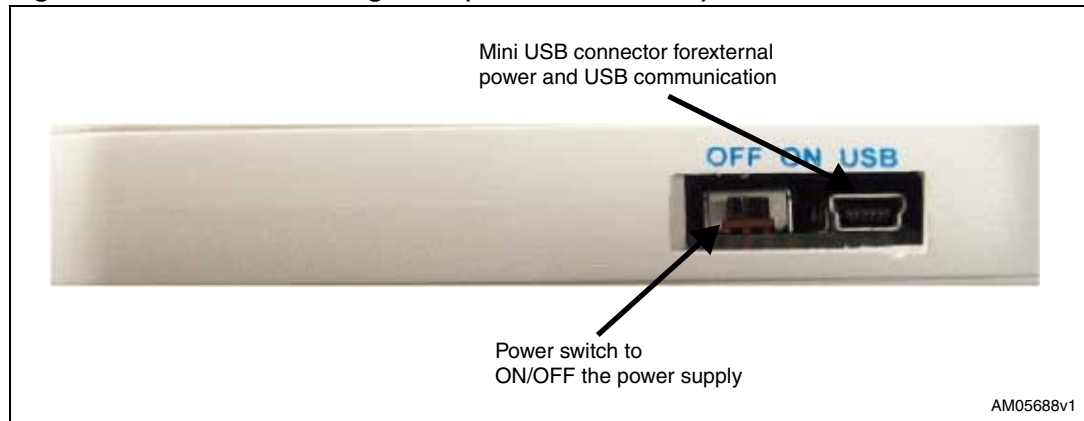
The smart monitoring station STEVAL-IFS014V1 includes a stand (see [Figure 3](#)).

Figure 4. Smart monitoring node (STEVAL-IFS015V1) - front view

The major components present on each smart monitoring node (STEVAL-IFS015V1) - front view are (see [Figure 4](#)):

- Graphical LCD
- Light-dependent resistor (LDR) for measuring ambient light intensity
- D1 - LED indicator for lamp
- D2 - LED indicator for alarm
- NW - LED indicator for ZigBee activity
- CH - LED indicator for battery charging
- PW - LED indicator for board power

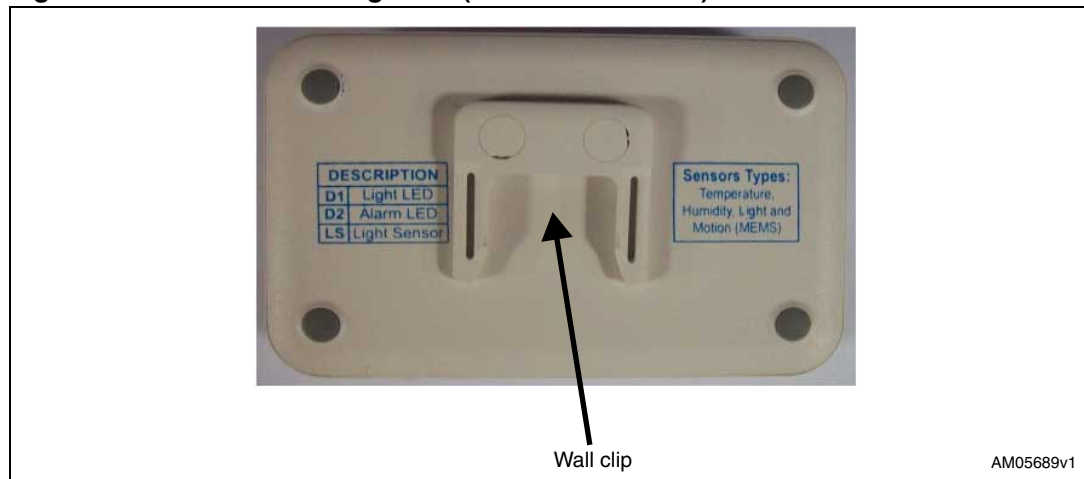
Figure 5. Smart monitoring node (STEVAL-IFS015V1) - side view



The major components present on each smart monitoring node (STEVAL-IFS015V1) - side view are (see [Figure 5](#)):

- USB - mini USB connector for power
- Power switch - used for switching board power on or off

Figure 6. Smart monitoring node (STEVAL-IFS015V1) - back view



The smart monitoring node (STEVAL-IFS015V1) has a clip to hang the board on the wall (see [Figure 6](#)).

Note: For a complete hardware description of the smart monitoring station (STEVAL-IFS014V1) and smart monitoring node (STEVAL-IFS015V1), please contact your local STMicroelectronics sales office.

2.4 Powering up the system

Both the smart monitoring station (STEVAL-IFS014V1) and smart monitoring node (STEVAL-IFS015V1) can be powered up using the USB power adaptor (5 V, 500 mA) or the mini USB cable (through a computer/laptop) or by using the battery (3.7 V Li-ion). The system uses the battery power only in case of unavailability of the external power supply. The system itself switches from the external power supply to battery and vice versa.

The system also has the capability to charge the battery when the external power supply is available at which time the system switches its power consumption from battery to mains and the battery starts charging.

On both the smart monitoring station and smart monitoring node, there is a power switch which is used to switch the supply on or off to the system.

There are two status LEDs:

- Power LED (PW): This indicates if the system is on or off
- Charging LED (CH): This indicates the charging status of the battery. If the battery is being charged from the external power supply, then this LED glows. If the external power supply is available but the battery is fully charged, then this LED is off.

Note: If no battery is connected and the system is powered using the USB supply, then the behavior of the charging LED 'CH' is unpredictable.

Note: For information regarding battery insertion in the STEVAL-IFS014V1 and STEVAL-IFS015V1, please see [Section 6.4](#).

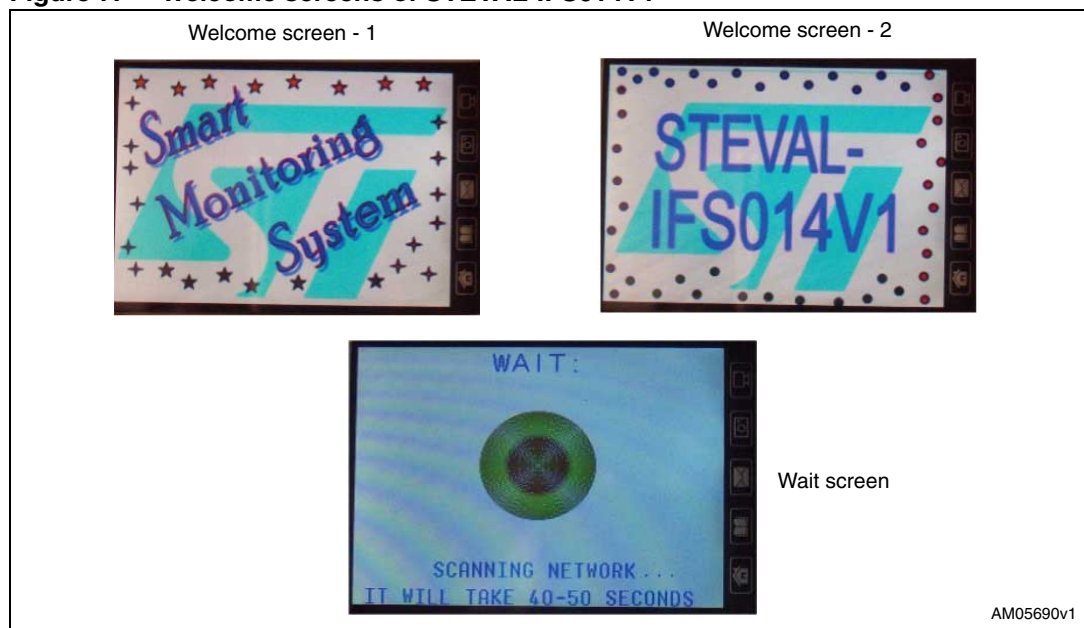
3 System operation

3.1 Starting up the system

The following steps indicate system and network startup:

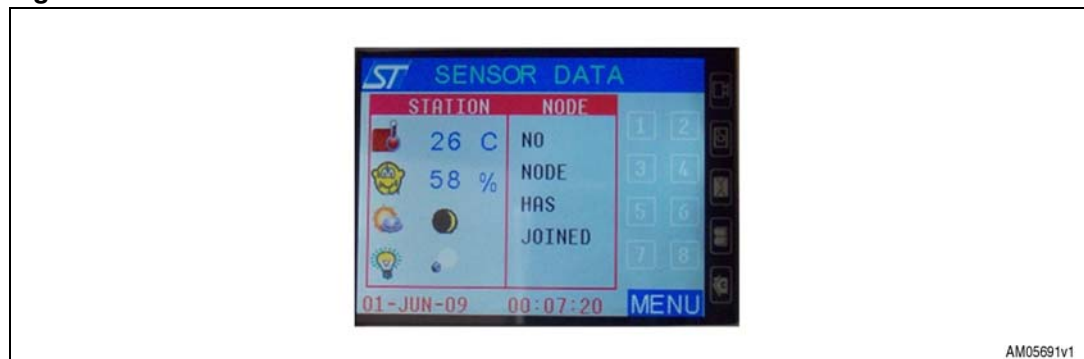
1. Power on the smart monitoring station (STEVAL-IFS014V1) using the power switch and the green LED (PW) glows, indicating that the station is powered up successfully.
2. After a moment, welcome screens appear on the TFT display.
3. After the welcome screens, a wait screen appears on the display indicating "SCANNING NETWORK". The user should not do anything until the network scanning is complete. After the scanning is complete, a screen indicating the text "NETWORK SCANNING COMPLETED" appears for a short time.

Figure 7. Welcome screens of STEVAL-IFS014V1



4. After all the above steps, the main sensor data screen appears on the display as shown in [Figure 8](#).

Figure 8. Initial data screen



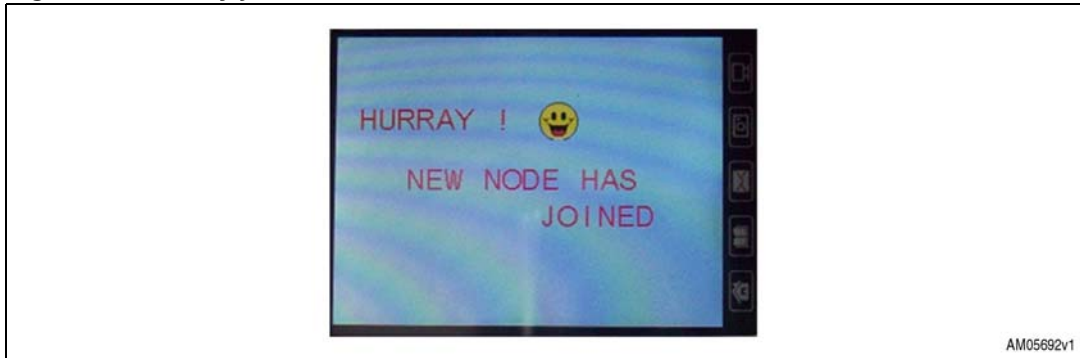
Note: For details of the components of the display window see [Section 4.1](#).

3.2 Establishing the network

Completion of the steps in [Section 3.1](#) creates the network for the smart monitoring station (STEVAL-IFS014V1). In order to join the different smart monitoring nodes (STEVAL-IFS015V1) to the network, the user should perform the following steps:

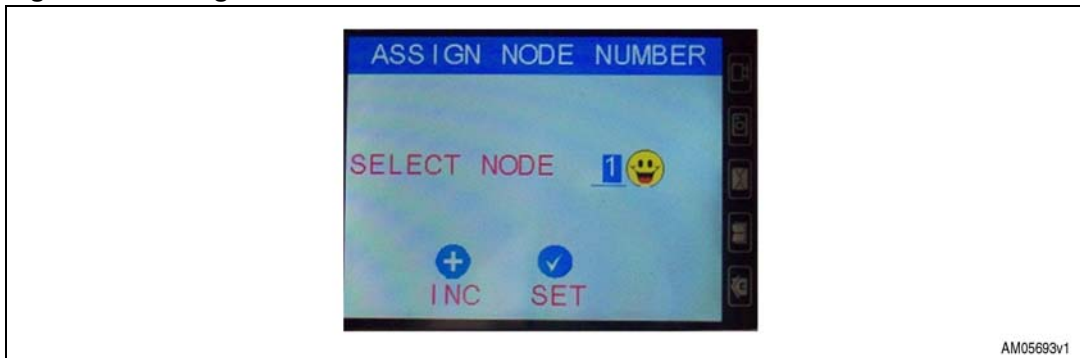
1. After the data screen is displayed on STEVAL-IFS014V1, the user should power on one of the smart nodes (STEVAL-IFS015V1) (for details see [Section 5](#)).
2. A screen on the display of STEVAL-IFS014V1 appears indicating that a new node has joined the system as shown in [Figure 9](#).

Figure 9. Newly joined node



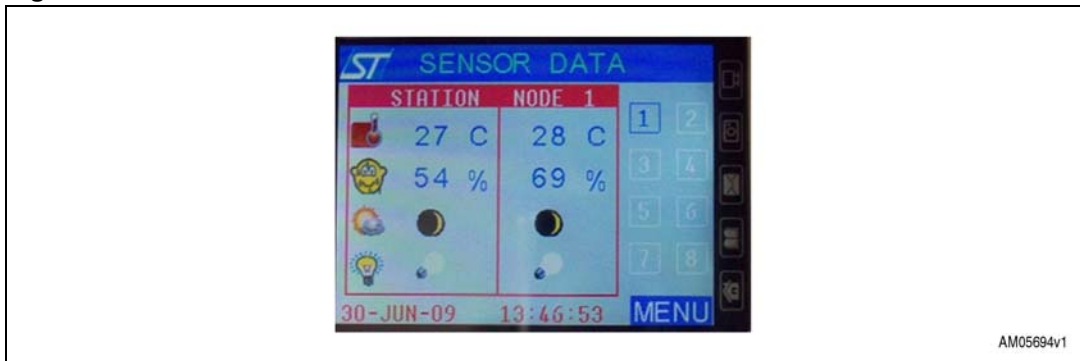
3. After a while, the user is asked to assign the node number to the newly joined node, as shown in [Figure 10](#).

Figure 10. Assign node number



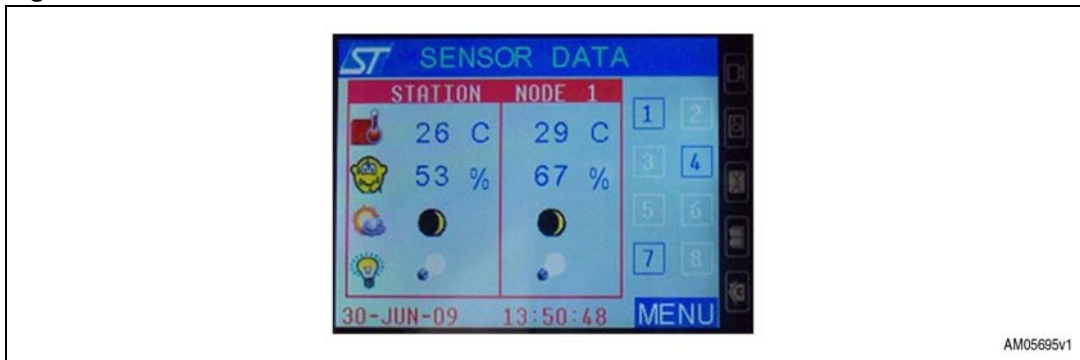
4. The user can assign the node number using the touchscreen by pressing the icons displayed on the screen (to see the meaning of the various icons, see [Section 4.4](#)).
5. As the node number is assigned to the joined node, the display returns to the default data screen, but with the displayed node number which has joined the system. The parameters of the node are displayed on the screen as shown in [Figure 11](#).

Figure 11. Sensor data screen with one active node



6. Similarly, the user can power up the various nodes (one at a time) and assign the various node numbers to them. Accordingly, the SENSOR DATA screen of STEVAL-IFS014V1 is updated, displaying the various joined nodes on the left side of the main screen as shown in *Figure 12*.

Figure 12. Sensor data screen with more than one active node



7. The system does not allow the user to assign the same node number to two different nodes which prompts an error message. The system does not exit the "ASSIGN NODE NUMBER" screen until the user assigns the node number to the newly joined number.

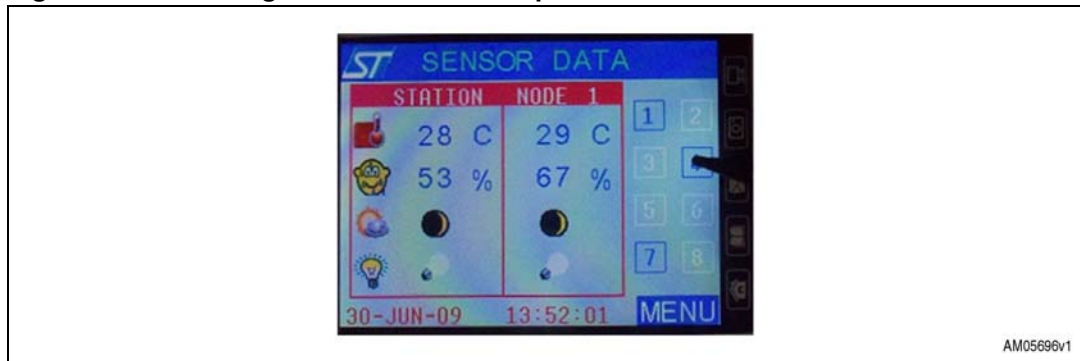
Note: It is recommended that no node should be switched on until the STEVAL-IFS014V1 shows the default data screen after startup.

3.3 Seeing the parameters of a specific node

When the very first node joins the system, the system itself selects that particular node and shows the various parameters of the node on the TFT display of the smart monitoring station (STEVAL-IFS014V1). If more than one node is connected to the system, then the user can select any of the connected nodes to display the various parameters on the sensor data screen of the STEVAL-IFS014V1.

The user can select any particular node by simply pressing the node number displayed on the screen using a stylus. The parameters of the selected node are displayed on the screen along with that of the smart monitoring station.

Figure 13. Selecting the node to see the parameters



Note: The user can see the parameters of only one node (STEVAL-IFS015V1) at a time along with the smart monitoring station (STEVAL-IFS014V1) on the sensor data screen.

Note: The parameters of the node and station are updated at regular intervals of time and the response is not instantaneous. If an event occurs at the node/station, it can take several seconds to be displayed. If the user wants to see the instantaneous response, he/she can simply press any part of the screen and the data is updated.

3.4 Data logging

The smart monitoring station (STEVAL-IFS014V1) has the capability to log the data of all the active nodes (STEVAL-IFS015V1) for more than one year and this data can be seen using the GUI developed for the system.

Three types of data are logged in the system:

1. Maximum and minimum values of weather parameters: the station stores the maximum and minimum values of all the weather parameters of all the nodes including itself once per day. These values are stored along with the time stamp. With this data the user can know not only the values, but also at what time of day the various parameters of the weather reached their maximum and minimum values. This data can be stored for more than one year.
2. Node movement data: the system stores the node movement data of all the active nodes along with the severity level of the movement, date and time stamp.
3. Simultaneous movement of all nodes / earthquake data: the system also stores the information of simultaneous movement of all active nodes/ earthquake data along with the date and time stamp.

All of the above data can be viewed using the GUI and by performing the following steps:

1. Go to the "USB MODE" of the smart monitoring station (STEVAL-IFS014V1) (see [Section 4.3.1](#))
2. Plug in the USB cable to the board and connect it to the computer which has the installed GUI and driver for the smart monitoring system
3. Operate the GUI and read the data logged in the smart monitoring station
4. To exit the USB mode, remove the USB cable from the board and press the display screen.

- Note:
- 1 The GUI can read the data only from the smart monitoring station (STEVAL-IFS014V1). USB communication is not available in the smart monitoring node (STEVAL-IFS015V1).
 - 2 The GUI reads the data from the board only once at startup and then processes that data. Once the file is read from the board, the board can be removed and can exit the USB mode.
 - 3 As long as the station is in USB mode, all other operations are stopped. The station should not be kept in USB mode for a long time after reading the file using the GUI to prevent losing the wireless link and data.

3.5 Alarm system

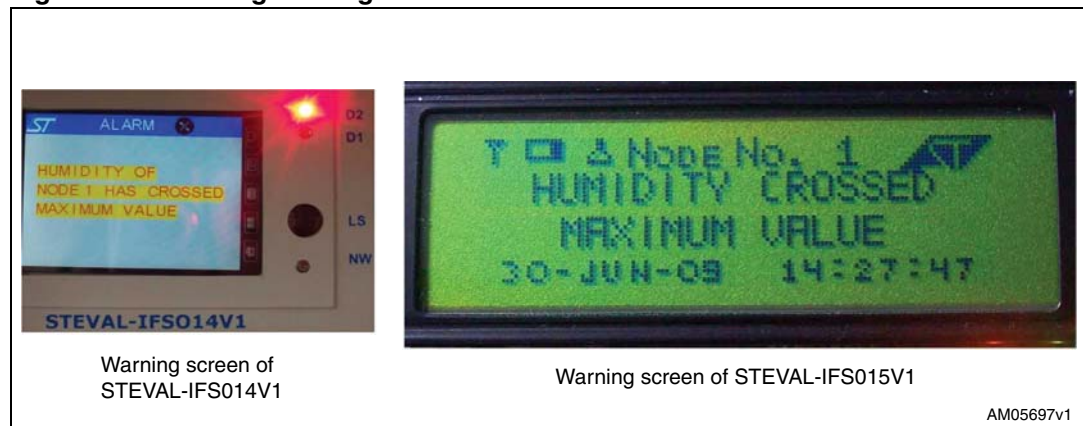
The system has the capability to detect various alarm conditions and give indication to the user. The system gives warnings for the following conditions.

3.5.1 Threshold crossing of weather parameters

The smart monitoring station and all the active nodes can be configured to display warnings upon crossing the maximum or minimum threshold of any of the weather parameters.

Whenever any weather parameter of any node crosses the configured maximum or minimum limit, then that node sounds an alarm. At the same time this information is transferred to the smart monitoring station through ZigBee and an alarm sounds also at the smart monitoring station along with the warning on the display (see [Figure 14](#)).

Figure 14. Warning messages



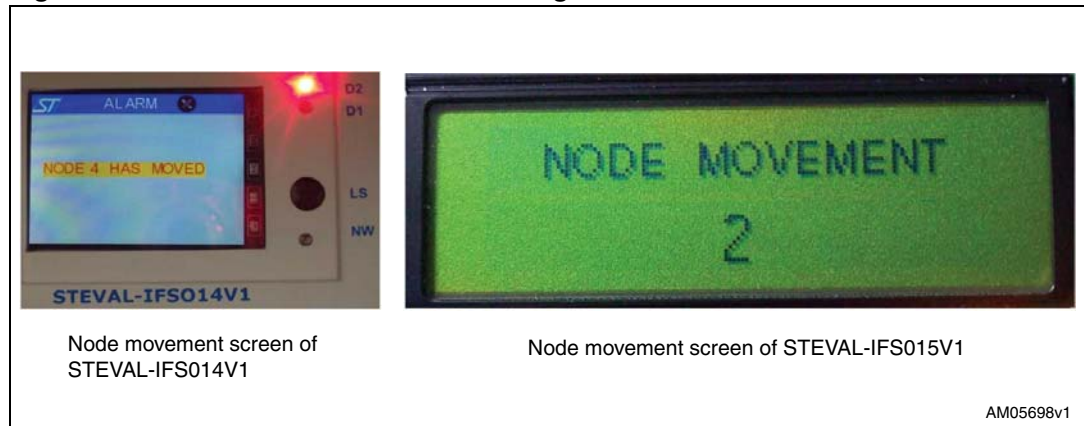
All the nodes and the smart monitoring station function in this manner.

- Note:
- For displayed warnings, if the user acknowledges the alarm by pressing the screen of the STEVAL-IFS014V1 when the warning is displayed on the screen, then the alarm does not post again for some time (~15 minutes). During this time interval the user can remove the cause of the alarm. If, after that time has passed the condition re-occurs, then the alarm is displayed again.

3.5.2 Node movement

Whenever any active node of the system vibrates or moves from its place, an alarm sounds at the node. At the same time, this information is transferred to the smart monitoring station along with the severity level of the movement. At the smart monitoring station an alarm sounds along with the alarm message on the display as shown in [Figure 15](#).

Figure 15. Node movement - alarm message

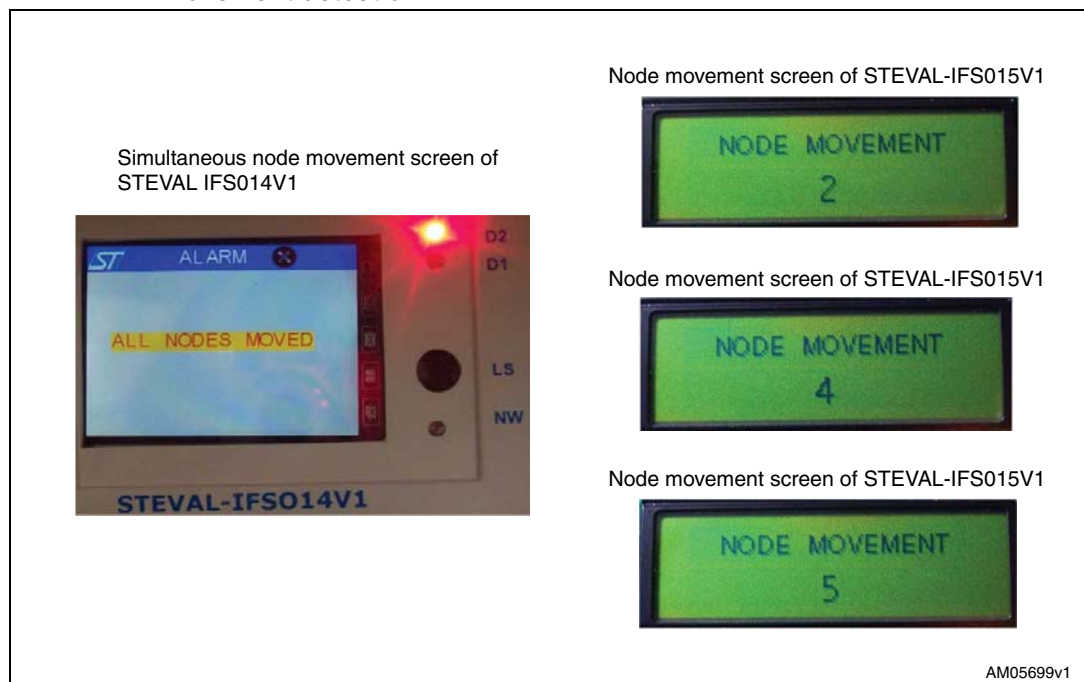


This information is also stored in the data logging system with the date and time stamp for future reference.

3.5.3 Simultaneous node movement

The system has the capability to detect the simultaneous movement of all the active nodes and sounds an alarm and displays a message on the screen as shown in [Figure 16](#).

Figure 16. Simultaneous node movement of nodes 2, 4 and 5 caused simultaneous movement detection



Note: 1 Simultaneous movement of all the active nodes of the system has been defined as "earthquake" for the system when logging the data into the system, but simultaneous movement of the nodes can also happen without an earthquake. The system is just

demonstrating the concept which has no relation with a real earthquake and has not been tested using any vibration-producing system until now.

- 2 *For the system to detect any simultaneous node movement, at least one node should be active in the system.*

3.5.4 Low battery and battery recovery

The system has the capability to detect a low battery of the smart monitoring station as well as that of all the nodes. Whenever the system detects a low battery, a warning is displayed. Also, on the data screen of the station (STEVAL-IFS014V1) the node number becomes red, indicating the low battery of that particular node. Similar information is displayed on the data screen of the node also (see [Section 4.1](#) and [5.1](#)).

When the battery is charged, the system detects the battery status and displays a message on the screen and the node number becomes blue again.

- Note:*
- 1 *When the battery value falls to 3.3 V, the board interprets this value as a low battery and the user should charge the battery. To prevent total discharging of the battery, the board switches off when the battery voltage falls to 2.5 V. The board shuts down after low-battery detection in approximately 2 hours, but this time depends on the type and rating of the battery being used.*
 - 2 *Even after the system shuts down, the user should charge the battery within 8 hours otherwise deep discharging can cause the permanent damage to the battery.*

3.5.5 Clock alarm

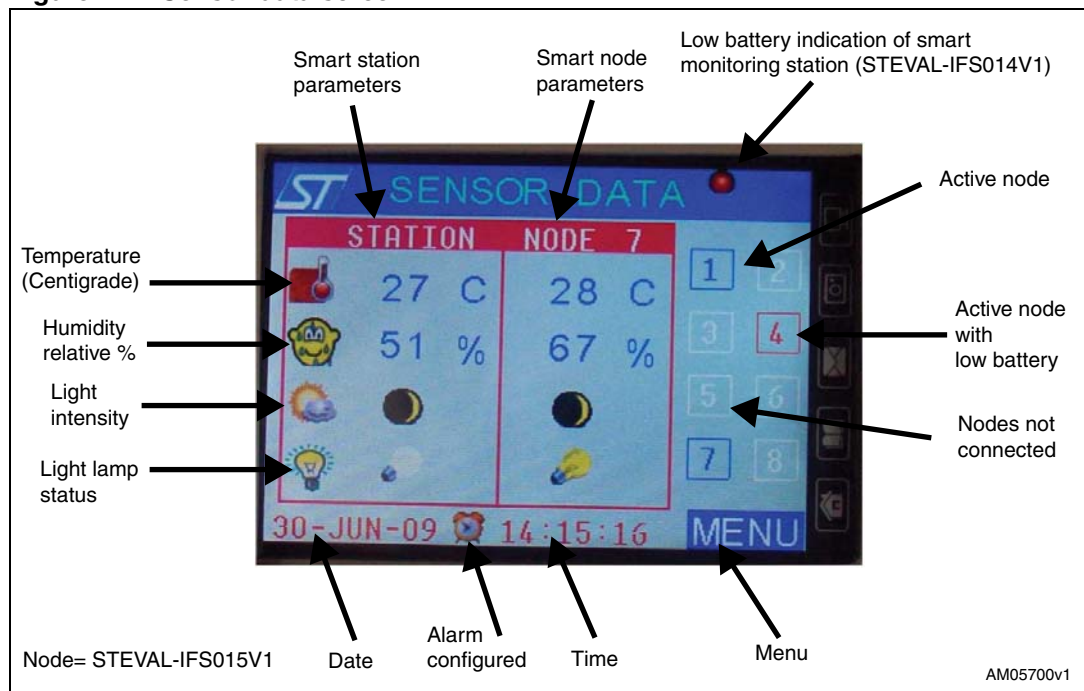
The smart monitoring station has the capability to configure the clock alarm for the same day. The alarm time should be greater than the current system time and when the system time matches that of the configured alarm time, the system sounds an alarm and a picture of a bell is displayed.

4 Description of the STEVAL-IFS014V1 (smart monitoring station)

The smart monitoring station (STEVAL-IFS014V1) acts as the coordinator for the ZigBee network to which all the smart monitoring nodes (STEVAL-IFS015V1) are connected. In addition to the network formation and parameter display, it is equipped with a very interactive menu with which the user can perform various actions. In this section of the document we explain in detail the smart monitoring station.

4.1 Components of the sensor data screen

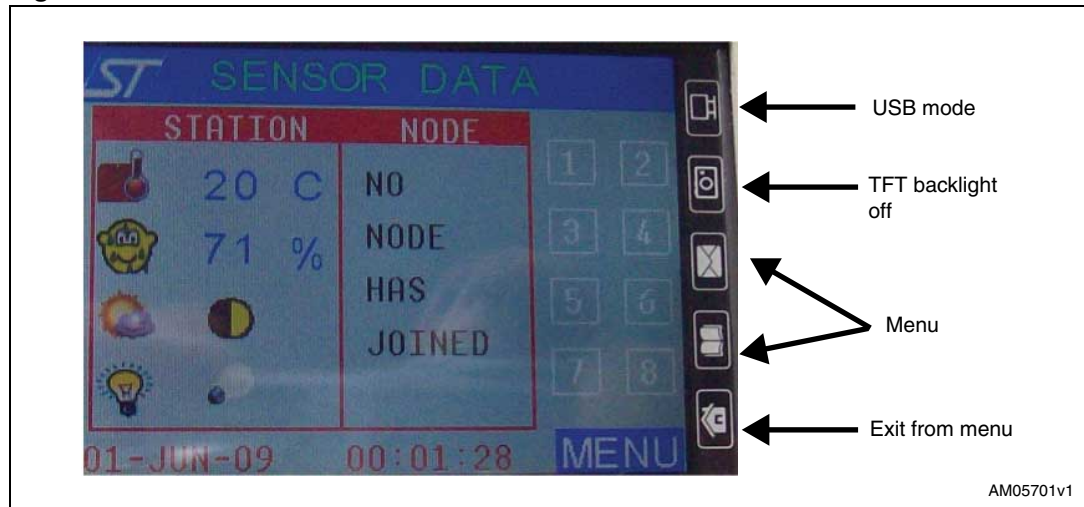
Figure 17. Sensor data screen



4.2 Dedicated symbols for important actions

Several white colored icons are situated on the right side of the TFT display of the STEVAL-IFS014V1 which have been configured for important functions (see [Figure 18](#)). These functions can also be performed using the menu options as explained earlier, but these dedicated icons are available at any time irrespective of where the user is in the system.

Figure 18. Dedicated icons for various actions

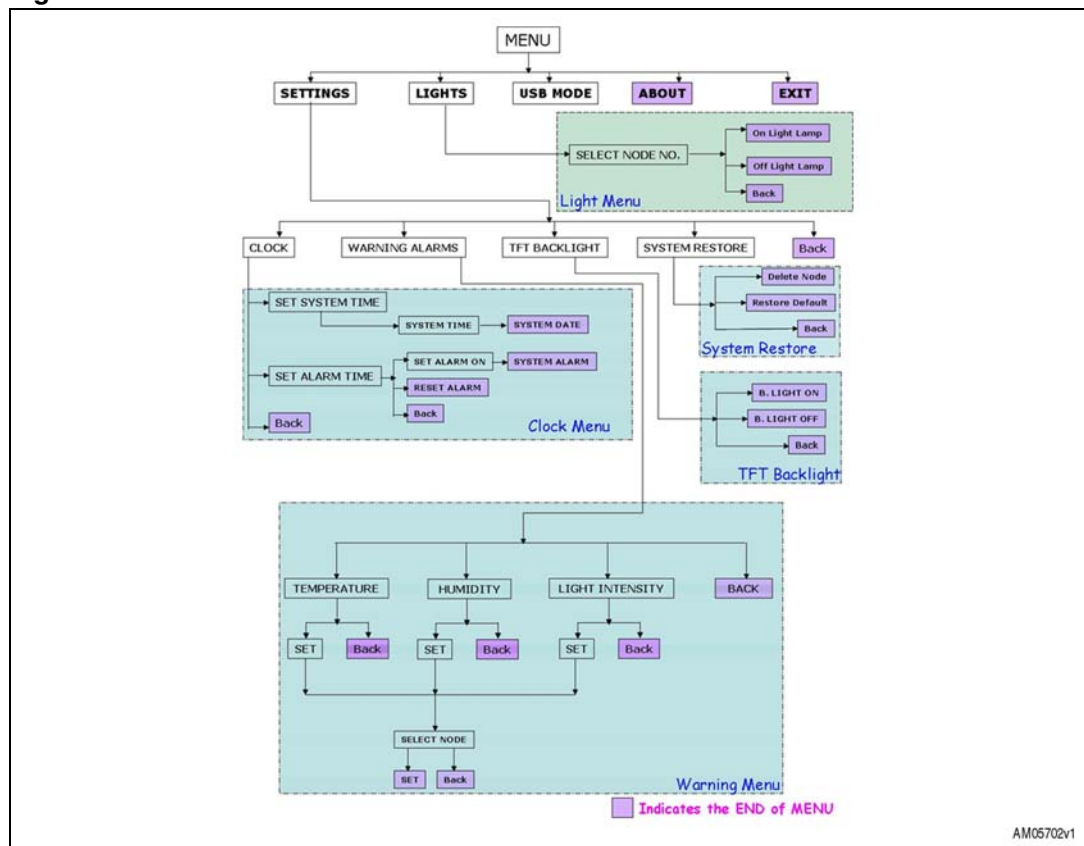


Note: These icons do not work when the system is in the "ASSIGN NODE NUMBER" screen.

4.3 Menu

The menu of the smart monitoring station has a hierarchical structure which is illustrated in the figure below.

Figure 19. Menu details



The menu options are explained in detail in the following sections.

4.3.1 USB mode

To get the data from the data logging system, the user has to go to the USB mode using the menu option available.

The user can exit the USB mode by pressing the screen. The system exits the USB mode and the default sensor data screen is displayed.

4.3.2 About

To obtain system information, the user can go to the "ABOUT" option of the menu. A screen describing the details of the system is displayed. There are four screens for the "ABOUT" option of the system and the user can navigate through these by touching the "NEXT" or "BACK" symbol on the screen.

4.3.3 Switching the lamp on or off (light application)

To switch the lamp on or off, the user should perform the following steps:

1. Go to "MENU/ LIGHTS", following the menu options available (see [Figure 19](#)).
2. Select the node number of the lamp to be controlled or "Node 0" for the smart monitoring station. Use the "INC" icon to increase the node number and "SET" to select the node number. Only the active nodes of the system are displayed when "INC" is pressed
3. After the node selection, the user is given options to switch the lamp on or off. The user can select any option and the action is performed accordingly.

Note: On the board, the lamp is indicated using an onboard LED. To control the actual lamp, additional hardware is required and that hardware is not the part of the system provided.

4.3.4 Setting the system time

To set the system time, the user should perform the following steps:

1. Go to "SET SYSTEM TIME" in the clock menu, following the menu options (see [Figure 19](#)).
2. Enter the time using the various navigational icons (options) available on the "SET SYSTEM TIME" screen (see [Section 6.1](#)).
3. After setting the system time, the user enters the "SET SYSTEM DATE" menu. If the user wants to enter the system date, he can set the system date using the same type of navigational keys as that of "SET SYSTEM TIME". The user can also exit without setting the system date. In this case only the system time is set and the system date does not change.

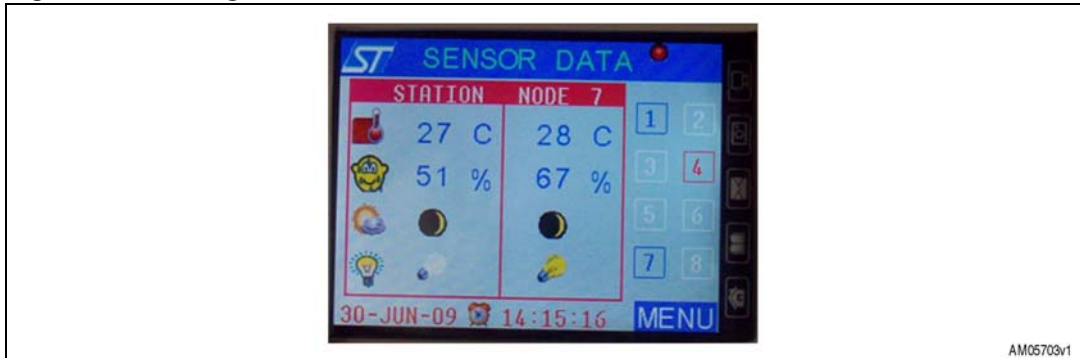
- Note:*
- 1 The system clock is displayed and entered in 24-hour format only.
 - 2 The system date can be entered only from the year 2000 onward. Previous dates are not allowed.
 - 3 The system date is displayed and entered in MM/DD/YYYY format.
 - 4 As the system clock is set in the smart monitoring station (STEVAL-IFS014V1), the clock of all the connected nodes is updated by the system itself.

4.3.5 Setting the clock alarm

To set the clock alarm, the user should perform the following steps:

1. Go to the "SET ALARM TIME" menu using the menu options available (see [Figure 19](#)).
2. The alarm time can be entered using the navigational options like those of the system time
3. If the time entered is not a valid time, then an error message is displayed on the screen and the system exits the menu
4. If the alarm time entered is valid, then the system alarm is set and a symbol of a clock alarm is displayed near the displayed time on the sensor data screen (see [Figure 20](#)).

Figure 20. Configured clock alarm indication



5. When the alarm time is reached, an alarm buzzes and a picture of a bell is displayed on the screen. After a while the default screen (sensor data screen) is again displayed.
6. The user can reset the alarm (turn the alarm off), at any time by using the "RESET ALARM" option available in the menu.

- Note:*
- 1 The alarm time should always be the greater than the system time by at least 2 seconds.
 - 2 The alarm time can be set only for the same day.
 - 3 The clock alarm feature is available only in the STEVAL-IFS014V1. The clock alarm cannot be set for any of the nodes.

4.3.6 Setting the various warning alarms

The user can set the maximum and minimum values of various weather parameters as alarm conditions for the different nodes. For this user should perform the following steps:

1. Go to the "WARNING ALARMS" menu using the various menu options available (see [Figure 19](#))
2. Select the parameter whose maximum/minimum values are to be configured
3. The screen for the configuration of the maximum/minimum values of the parameter selected is displayed on the screen
4. The user can enter the values using the navigational options available on the screen (these are same as those of "set system time")
5. If the values entered by the user are not valid, an error message is displayed on the screen and the system exits the menu
6. If the values entered are valid, then the system moves to the "SELECT NODE" menu. The user can select any node of the parameter to be configured or "NODE 0" for the smart monitoring station
7. If the node selected by the user is not active, then an error message is displayed on the screen and the system exits the menu
8. If the node selected is active, then the warning condition of that particular node for that particular parameter is configured.

Note: The maximum value of any parameter should be greater than the minimum value.

4.3.7 No-display mode (power saving)

If the user does not want to see the display and wants to save the power, there is a provision to switch off the backlight of the display.

The user should perform the following steps:

1. Go to the "B. LIGHT OFF" option of the menu using the various menu options (see [Figure 19](#))
2. Upon selecting this option, after 15 seconds the backlight of the display turns off and the display is not visible to the user
3. The system exits this mode and the display resumes by simply touching the screen
4. If after selecting this option, the user wants to change his/her decision before 15 seconds, he/she can go to the menu of "B.LIGHT OFF" and select this option. In this case the system does not enter the no-display mode.

4.3.8 System restore

The user can configure the system for the following settings:

Delete node

The user can delete the details of the node which are already stored in the system. The system deletes the node details and that space is freed for the new node. If the same node rejoins the system, then the user re-assigns the node number to that node.

Note: Only those nodes whose information is stored in the station and are not active can be deleted.





Restore default

The user can restore the factory default values by selecting the "RESTORE FACTORY" option of the menu (see [Figure 19](#)). For the details of the factory default values see [Section 6.2](#).

Note: This restores only the factory default values of the smart monitoring station (STEVAL-IFS014V1) and not those of the active nodes (STEVAL-IFS015V1).

4.4 Meaning of navigational icons

There are four different navigational icons displayed on the menu screens where the user has to enter values for certain settings. The meaning of these icons is as follows:

-  INC: The function of this icon is to change the value where the pointer is currently placed. In general this increments the digit and upon reaching the maximum limit, the value rolls over and increments again.
-  MOVE: The function of this icon is to change the current place of the pointer. Upon pressing this icon the pointer shifts by one place to the right. When the pointer reaches the last place, upon pressing this icon again, the pointer rolls over to the first place with the contents remaining unchanged. The user can again update the contents of the place by using the INC icon.
-  SET: The function of this icon is to set the entered data into the system. If the data entered is valid, then the data is accepted and if it is not valid, the system generates an error and exits the menu.
-  BACK: The user can go back to the previous menu without doing any settings using this icon.

Note: Throughout the complete system the meaning of these icons is always same and serves the same purpose regardless of the data to be entered.

5 Description of the STEVAL-IFS015V1 (smart monitoring node)

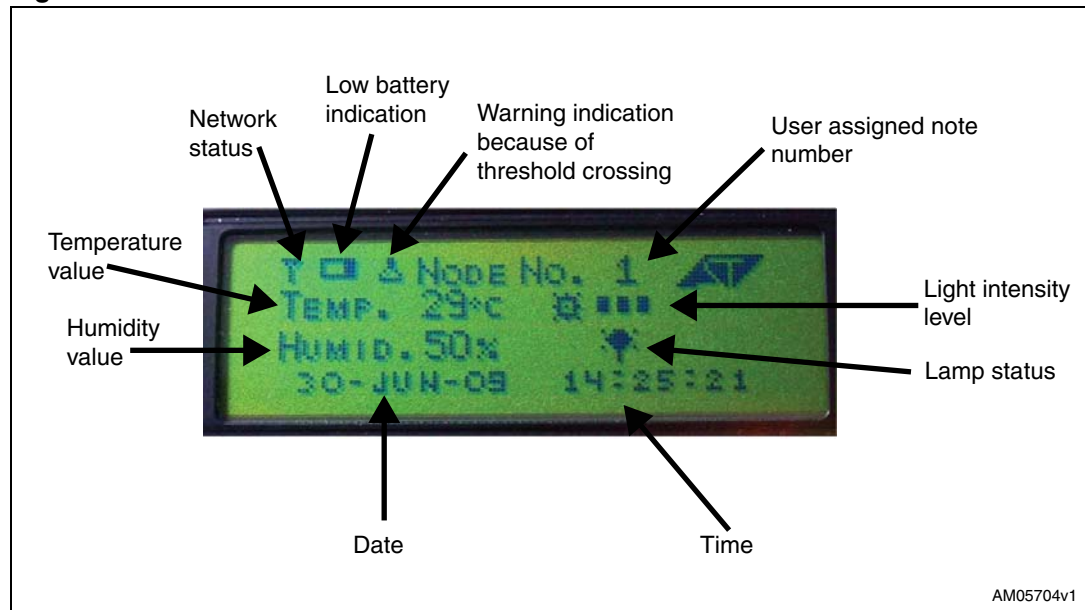
The smart monitoring node (STEVAL-IFS015V1) acts as the end device of the of the ZigBee network developed by the smart monitoring station (STEVAL-IFS014V1). The smart monitoring node contains a 122 x 32 graphical LCD which is used to display the information. In this section of the document we explain in detail the smart monitoring node.

As previously stated, the smart monitoring node can be powered up using the USB supply or a 3.7 V Li-Ion battery. Once the node is powered up using the on/off switch, various welcome messages are displayed on the screen. After some time the default screen or the main screen of the display appears which contains the various parameters and other information.

5.1 Components of default display screen

[Figure 21](#) shows the complete default screen of the smart monitoring node (STEVAL-IFS015V1). Some of the components of the screen may not be visible depending on the conditions.

Figure 21. Details of data screen of STEVAL-IFS015V1

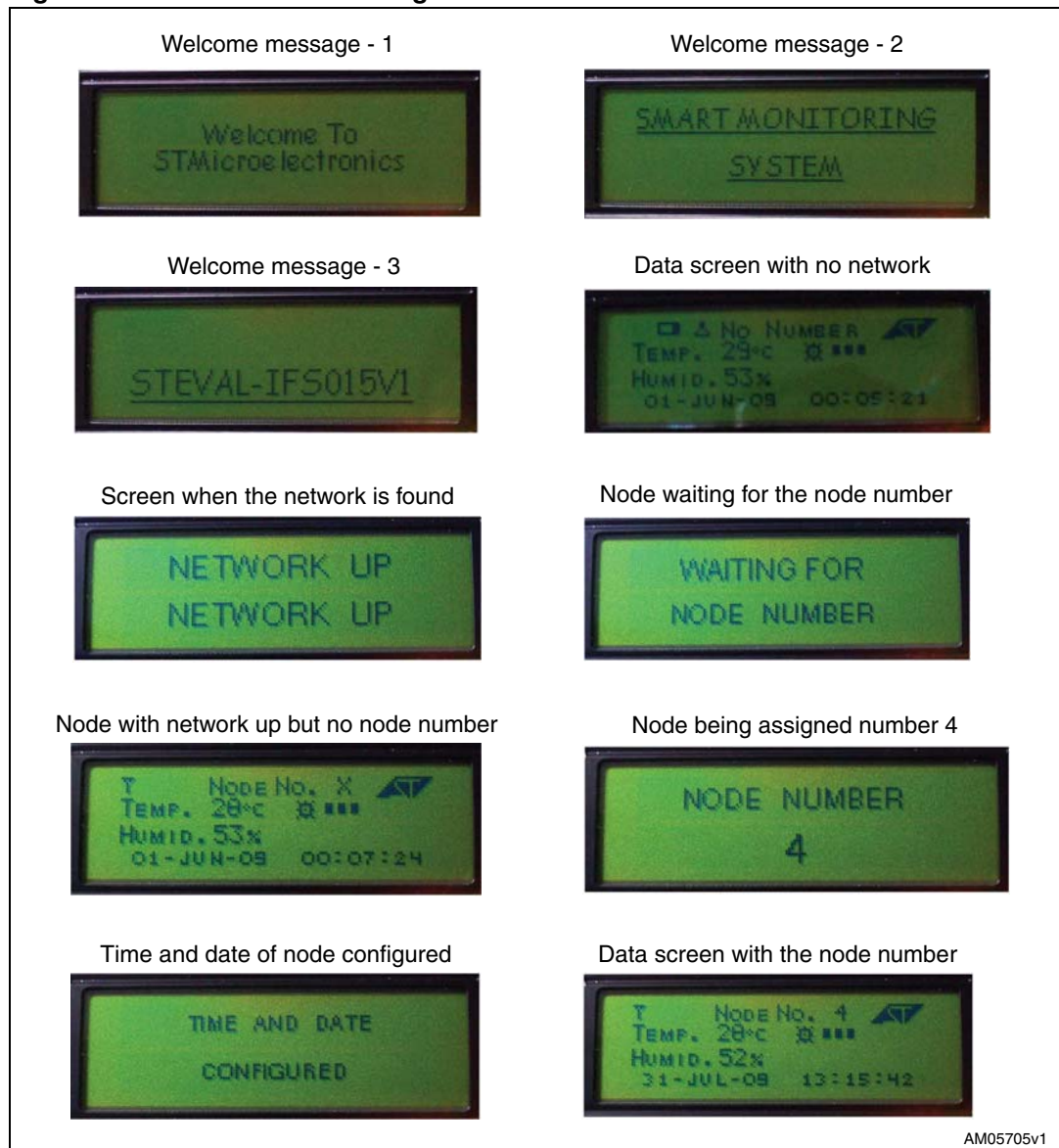


Note: The humidity value of the smart node (STEVAL-IFS015V1) can take some time to stabilize.

5.2 Other messages

During the operation of the smart monitoring system, a number of different messages are displayed on the screen of the smart monitoring node. These messages are self-explanatory, but some have been displayed in [Figure 22](#).

Figure 22. Various other message screens of STEVAL-IFS015V1



5.3 JTAG connectivity

The smart monitoring node has the capability of in-circuit debugging using the JTAG tool. In this case the node must be opened and the berg strip (8 x 2 pin with 2.54 mm pitch) should be soldered at J2. When the JTAG is connected to the smart monitoring node and the node is powered up, then (after the welcome messages) a message of non-availability of the lamp and alarm LEDs is displayed. This is because the JTAG lines of the MCU have been shared with the JTAG and LEDs of the lamp and alarm.

6 Additional setup information

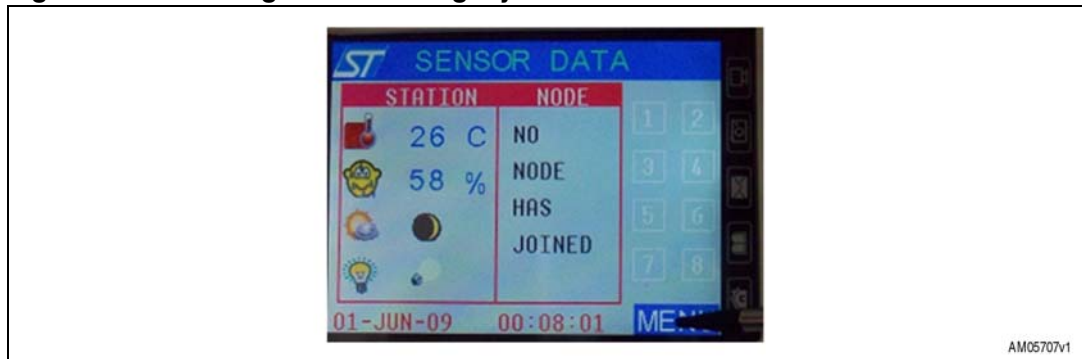
6.1 Complete example of menu navigation of STEVAL-IFS014V1

In this section, a complete example of menu navigation is explained by demonstrating how to set the system time. Taking this example as a reference, the user can navigate through various menu options and can perform any operation.

To set the system time the user should perform the following steps:

1. Select the menu from the main screen using the touchscreen.

Figure 23. Selecting “MENU” using stylus



2. The menu screen opens.

Figure 24. Menu



3. Select “SETTINGS” by pressing the touchscreen.

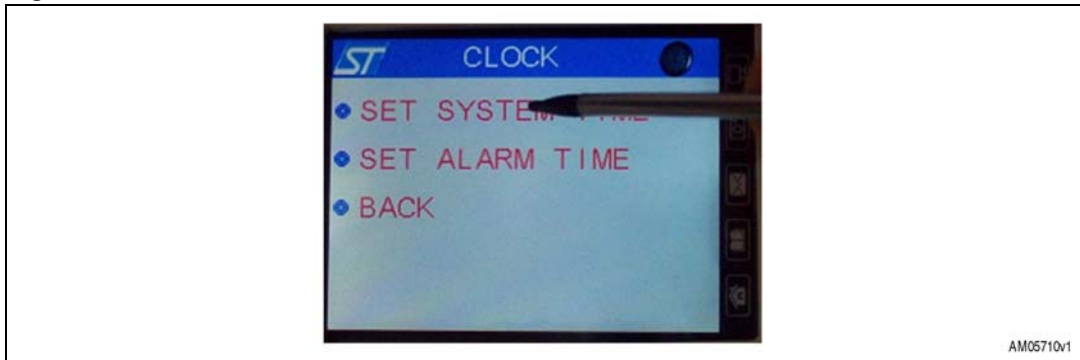
- 4. The settings menu opens.

Figure 25. "SETTINGS" menu



- 5. Select "CLOCK" using the touchscreen.
- 6. The clock menu opens.

Figure 26. "CLOCK" menu



- 7. Select the "SET SYSTEM TIME" option using the touchscreen.
- 8. The system time menu opens.

Figure 27. "SYSTEM TIME" - 1



9. Press the INC icon using a stylus which increments the ten's place of the hour from 0 to 1.

Figure 28. "SYSTEM TIME" - 2



10. In the same way the ten's place of the hour can be incremented to 2. If it is incremented again, the digit rolls over and starts from 0 again.
11. After the user has selected the correct digit for the ten's place of the hour, then he should move to the next place (one's place of the hour) by pressing the MOVE icon using a stylus. The pointer of the time setting moves to the one's place of the hour and is highlighted as shown in the figure below.

Figure 29. "SYSTEM TIME" - 3



12. Pressing the INC icon increases the digit at the one's place of the hour. When the required digit is displayed at the one's place of the hour, then the user can move to the next place (ten's place of the minutes) using the MOVE icon, as in the previous step.
13. Similarly, the user can select the total system time using the INC and MOVE icons.

14. When the required system time is selected, the user can set the time in the system using the “SET” icon by simply pressing it on the screen. The system time is set in the system and a new window to set the “SYSTEM DATE” is activated, as shown in [Figure 31](#).

Figure 30. “SET SYSTEM TIME” - 4



15. When the time is set, a new screen to set the date appears.

Figure 31. “SET SYSTEM DATE”



16. The user can set the system date using the previous steps and the system exits the menu after setting the time and date in the system.

- Note:*
- 1 As the time and date in the smart monitoring station are set by the user, the smart monitoring station itself updates this information in all the active nodes.
 - 2 Regardless of where the user is in the menu, he/she can always exit the menu using the EXIT option.

6.2 Factory default values

The smart monitoring station (STEVAL-IFS014V1) and smart monitoring node (STEVAL-IFS015V1) are programmed with the following factory default values:

1. Lamp status: the lamp (D1) is off by default
2. Weather parameters alarm conditions:
 - a) Temperature: maximum +50 °C, minimum +10 °C
 - b) Relative humidity: maximum 99%, minimum 20%
 - c) Light intensity: maximum 6, minimum 1 (relative scale)

6.3 LEDs

Both the smart monitoring station (STEVAL-IFS014V1) and smart monitoring node (STEVAL-IFS015V1) have 5 different LEDs with the following description:

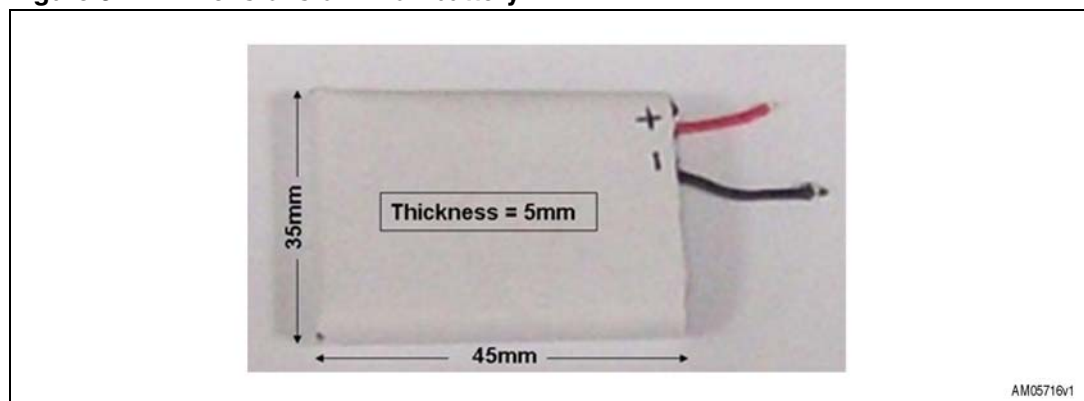
1. PW (power LED - green) - this LED glows if the system is on
2. CH (charging LED - orange) - this LED shows if the battery is charging. If the external supply is available and the battery is charging, then this LED glows. When the battery is fully charged or if the external supply is removed, this LED turns off
3. D2 (alarm LED - red) - this LED glows whenever there is an error or alarm
4. D1 (lamp LED - yellow) - this LED functions as the lamp which can be switched on or off from the smart monitoring station by the user using the light application of the system
5. NW (network LED - blue) - this LED blinks whenever there is any communication using ZigBee.

6.4 Battery connection

In this section we explain how the user can connect the battery to the STEVAL-IFS014V1 and STEVAL-IFS015V1. Both the systems have been designed for the Li-Ion battery of the dimensions 45 x 35 x 5 mm (see figure below). The battery dimensions are similar to the battery with part number BL-5B from Nokia.

For the RTC power backup, a socket for the 3 V coin-type CR2032 battery is provided.

Figure 32. Dimensions of Li-Ion battery



6.4.1 Battery connection - STEVAL-IFS014V1

The user should do the following steps in order to connect the battery to the STEVAL-IFS014V1 board:

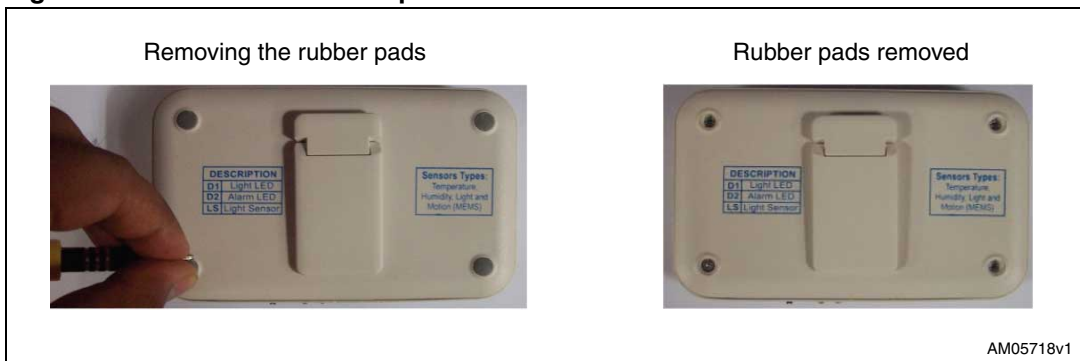
1. Turn the board upside down and place it on a table.

Figure 33. Back of STEVAL-IFS014V1 and screwdriver



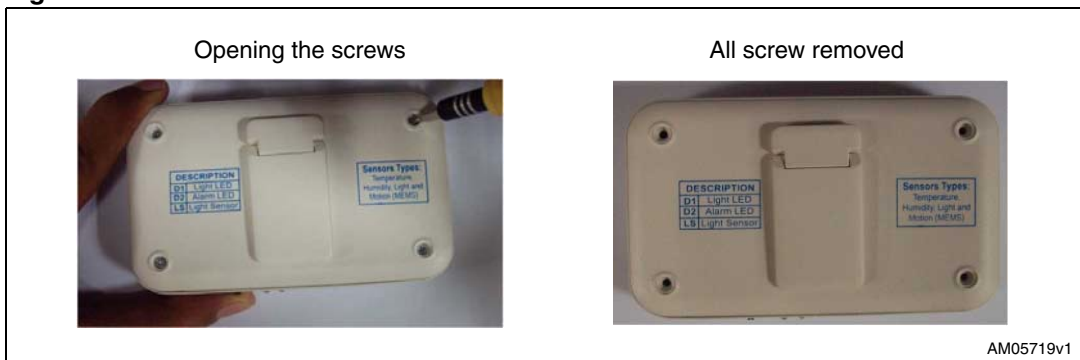
2. Remove the rubber pads from the holes.

Figure 34. Removal of rubber pads



3. Remove all the screws using the screwdriver.

Figure 35. Removal of screws



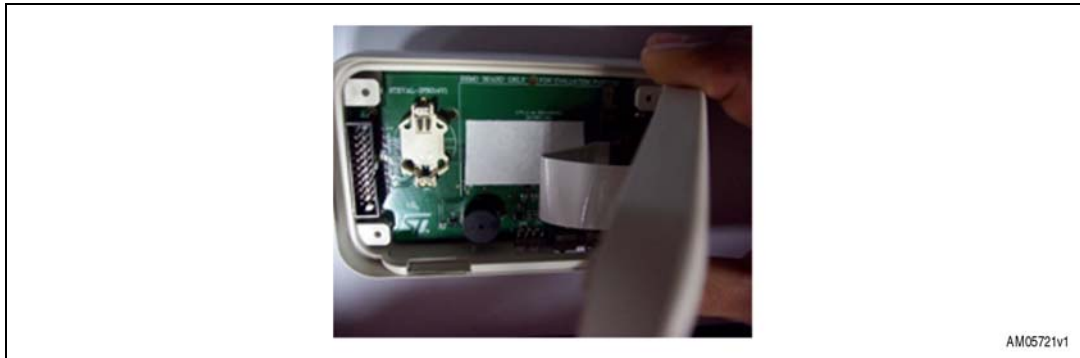
4. Turn the board with the front facing up and place it on the table

Figure 36. Front of STEVAL-IFS014V1



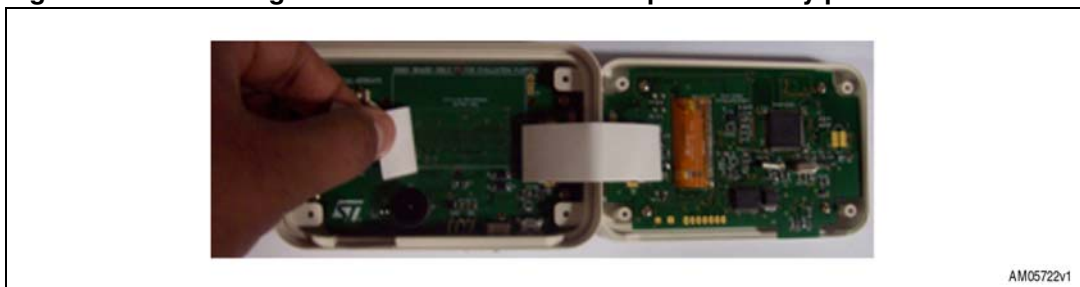
5. Remove the top cover of the board and move it to the side of the board. This should be done very carefully because the top and bottom of the board are connected by a flex cable and if this becomes damaged, the system may experience damage.

Figure 37. Opening the top cover



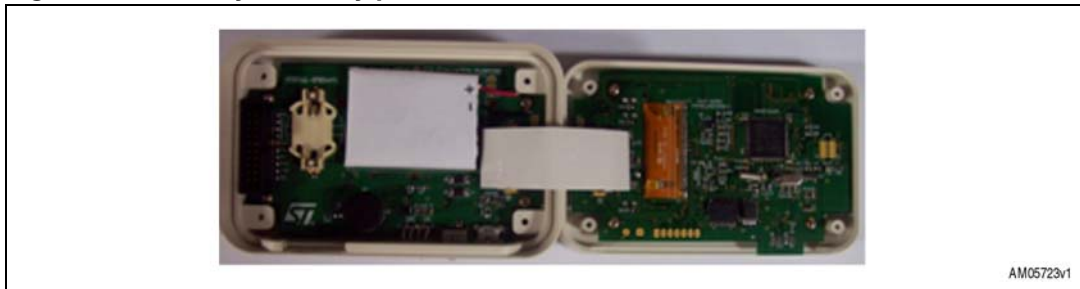
6. When the board is open, remove the cover of the tape where the battery is to be placed.

Figure 38. Removing the cover of double-sided tape for battery placement



- 7. Place the battery on the space provided.

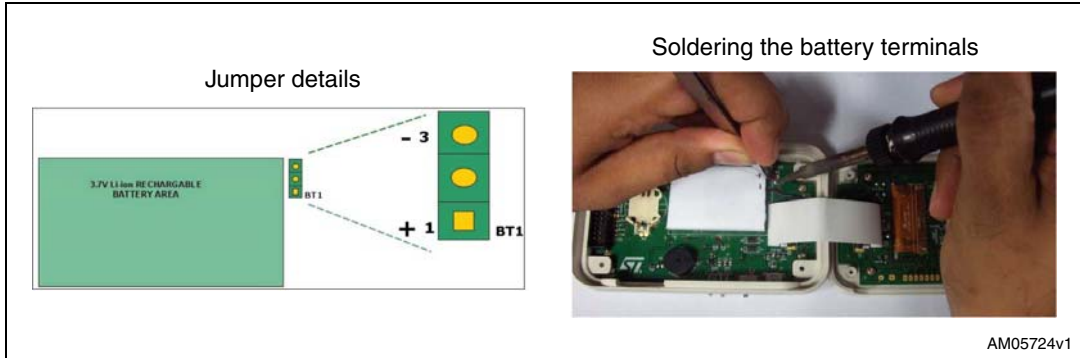
Figure 39. Battery correctly placed



AM05723v1

- 8. Solder the positive terminal of the battery to the first pin (square) of the jumper designated as BT1. Connect the negative terminal of the battery to the third pin of the jumper designated as BT1.

Figure 40. Battery soldering

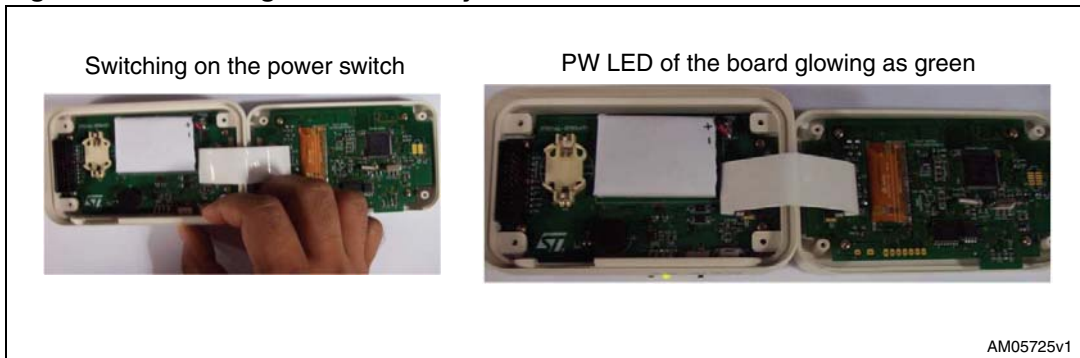


AM05724v1

During soldering, care should be taken to avoid damage to the case and the flex cable.

- 9. Switch on the power switch and the PW LED glows green which confirms that the battery is connected in the proper manner.

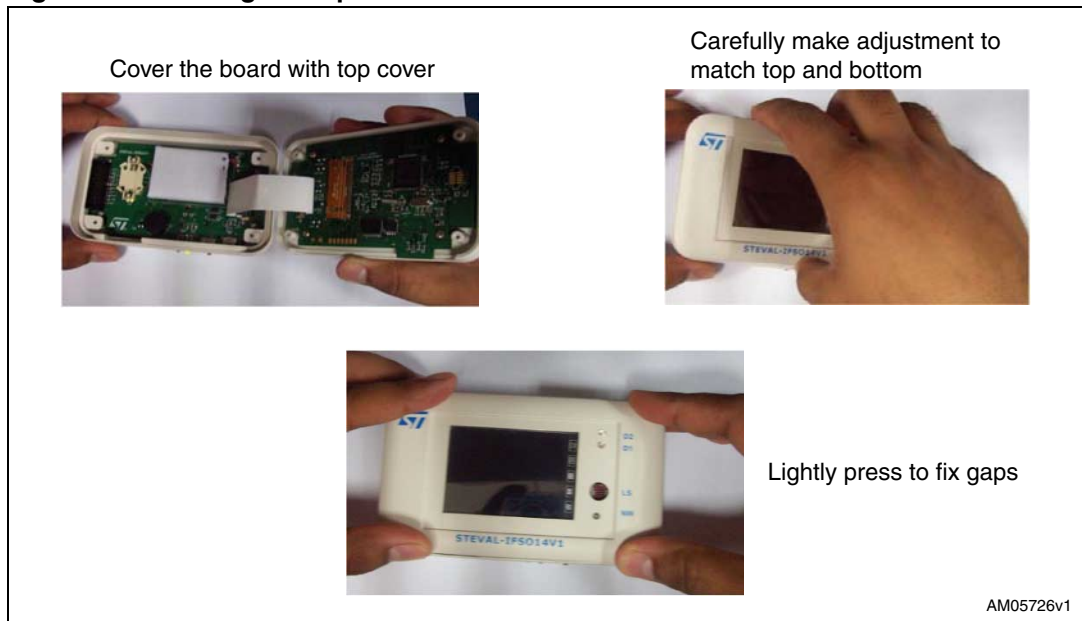
Figure 41. Checking that the battery connection is correct



AM05725v1

10. Close the case with the top cover.

Figure 42. Closing the top cover of the case



11. Tighten the screws to close the case. Care should be taken that the screws are not tightened with too much force as this can damage the TFT display or LEDs.

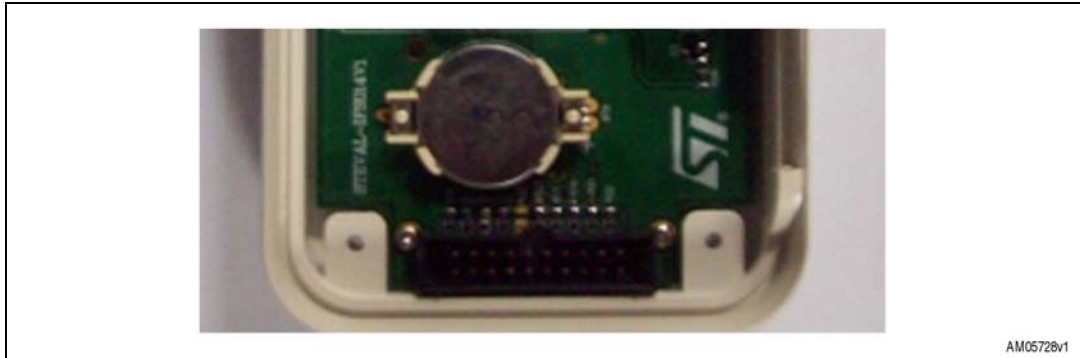
Figure 43. Tightening the screws



12. Apply the rubber pads on the screws. Now the smart monitoring station (STEVAL-IFS014V1) is ready to operate on battery.

Note: For the RTC power backup (that is, to make the clock operate even when the station is not powered up), a 3 V CR2032 battery should be inserted in the socket BT2.

Figure 44. 3 V coin-type CR2032 battery insertion for RTC power backup



AM05728v1

6.4.2 Battery connection - STEVAL-IFS015V1

The user should do the following steps in order to connect the battery to the STEVAL-IFS015V1 board:

1. Turn the board upside down and place it on a table.

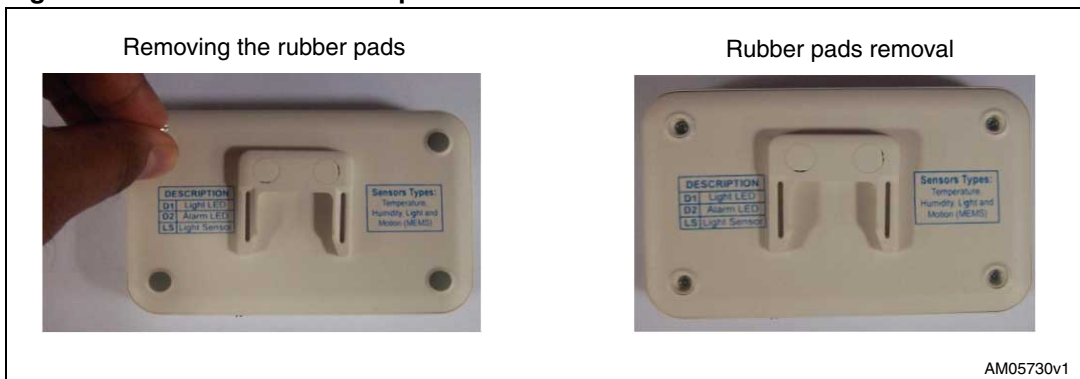
Figure 45. Back of STEVAL-IFS015V1 and screwdriver



AM05729v1

2. Remove the rubber pads from the holes.

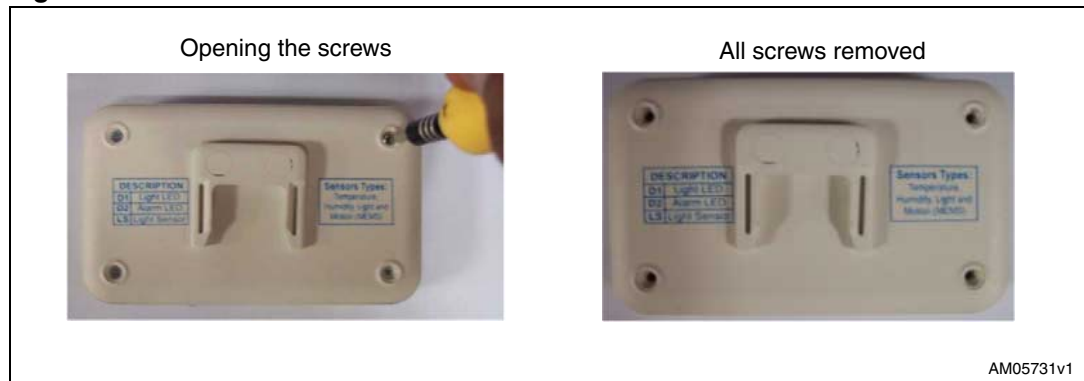
Figure 46. Removal of rubber pads



AM05730v1

3. Remove all the screws using the screwdriver.

Figure 47. Removal of screws



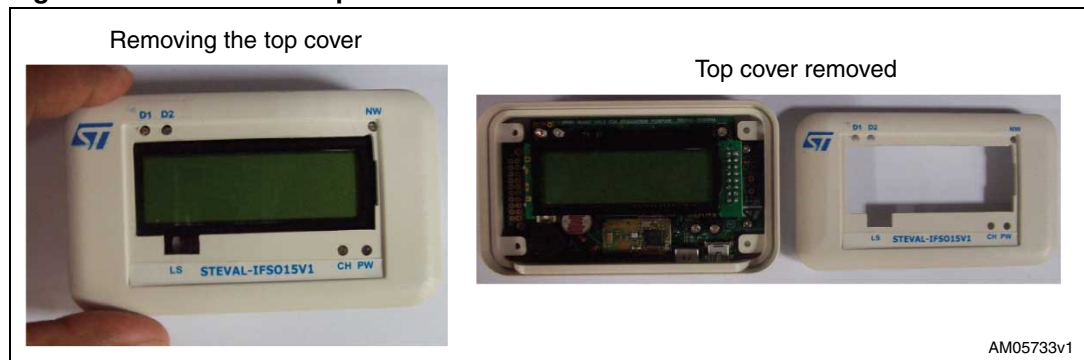
4. Turn the board with the front facing up and place it on the table

Figure 48. Front of STEVAL-IFS015v1



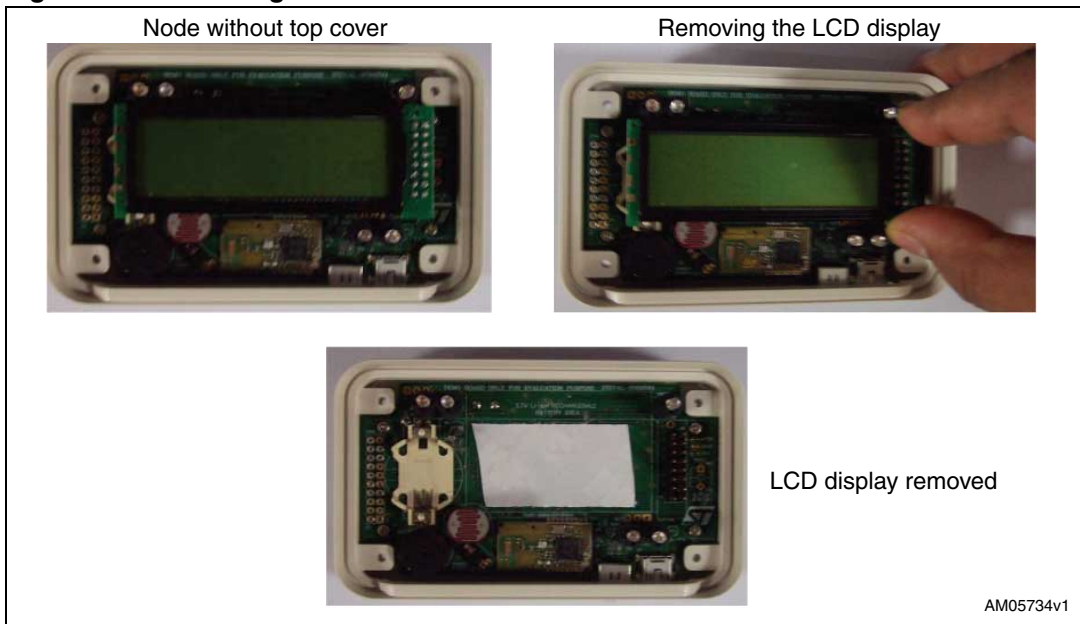
5. Remove the top cover of the board and move it to the side of the board. This should be done very carefully because the top has the cutouts for the LCD and LEDs. Care should be taken that the LEDs and LCD are not bent.

Figure 49. Removal of top cover of the case



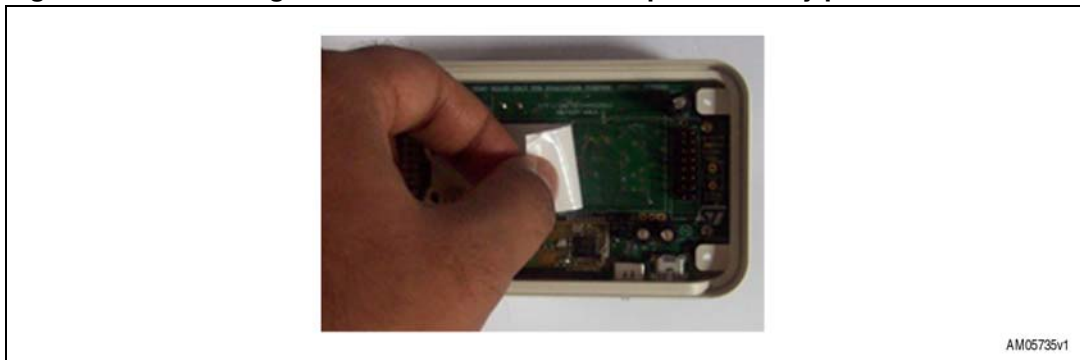
- 6. Remove the LCD from the jumper J4.

Figure 50. Removing the LCD



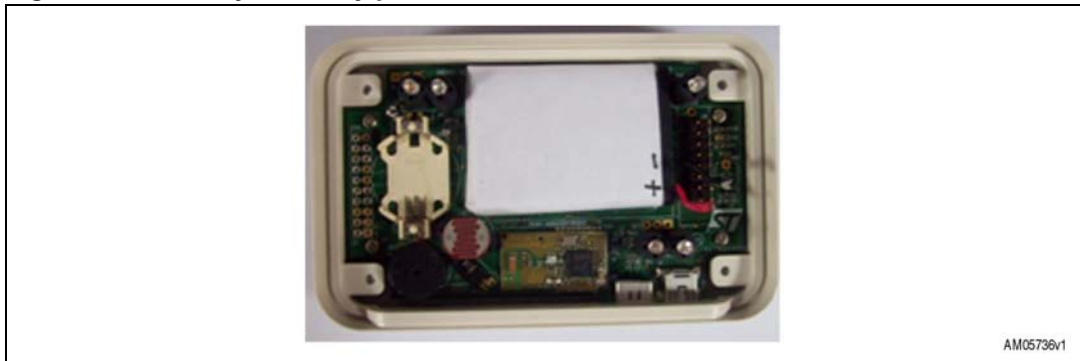
- 7. When the board is open, remove the cover of the tape where the battery is to be placed.

Figure 51. Removing the cover of double-sided tape for battery placement



- Place the battery on the space provided.

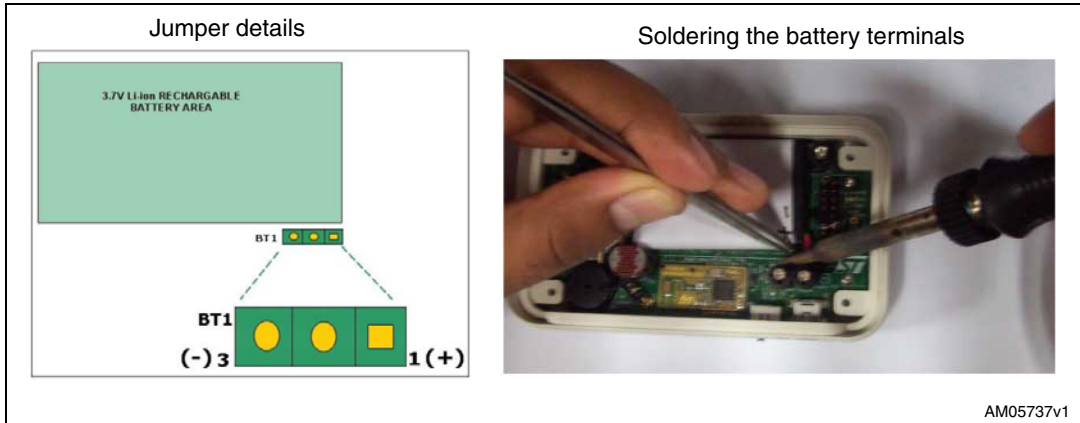
Figure 52. Battery correctly placed



AM05738v1

- Solder the positive terminal of the battery to the first pin (square) of the jumper designated as BT1. Connect the negative terminal of the battery to the third pin of the jumper designated as BT1.

Figure 53. Soldering the battery

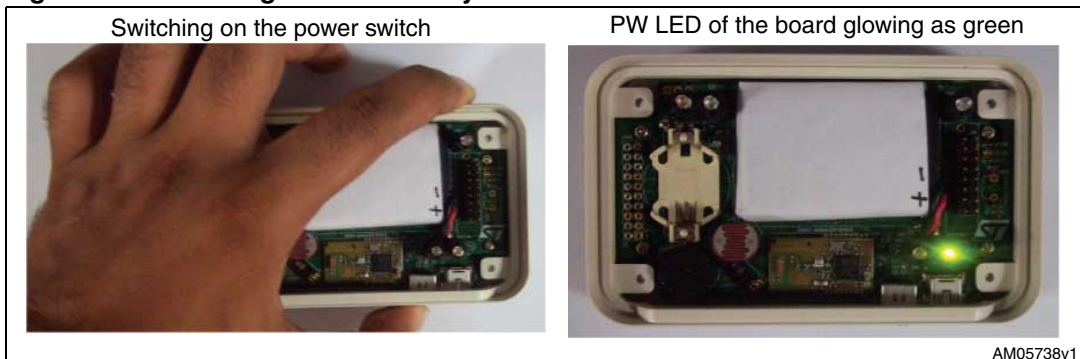


AM05737v1

During soldering, care should be taken to avoid damage to the case and the nearby LEDs.

- Switch on the power switch and the PW LED glows green which confirms that the battery is connected in the proper manner.

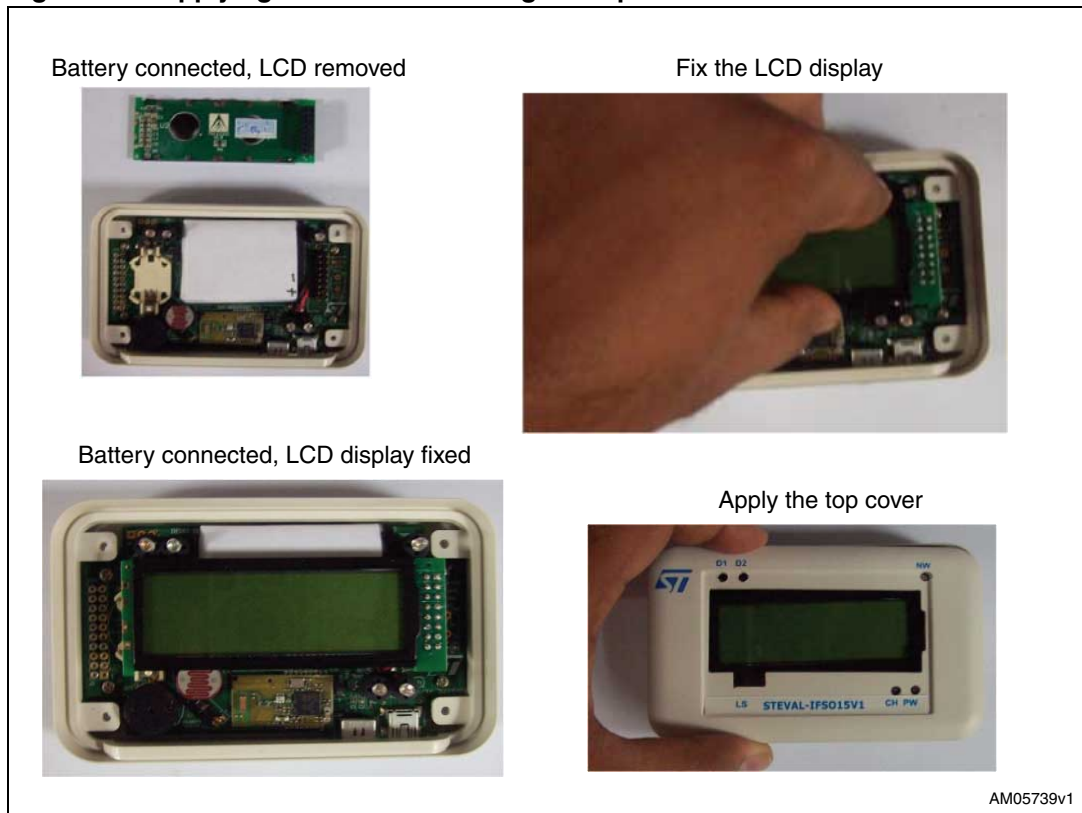
Figure 54. Checking that the battery connections are correct



AM05738v1

- 11. Close the case with the top cover.

Figure 55. Applying the LCD and closing the top cover of case



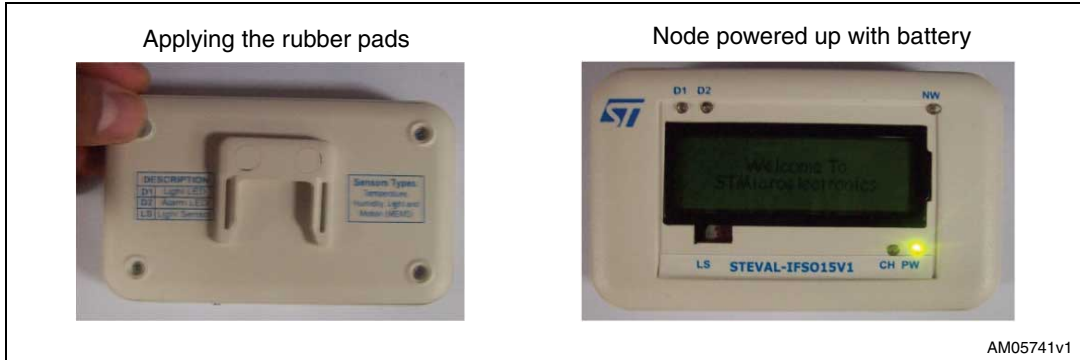
- 12. Tighten the screws to close the case. Care should be taken that the screws are not tightened excessively as this can damage the display or LEDs.

Figure 56. Tightening the case with screws



- 13. Apply the rubber pads on the screws. Now the smart monitoring node (STEVAL-IFS015V1) is ready to operate on battery.

Figure 57. Applying the rubber pads and STEVAL-IFS015V1 powered up with battery



Note: For the RTC power backup, (that is, to make the clock operate even when the station is not powered up), a 3 V CR2032 battery should be inserted in the socket BT2.

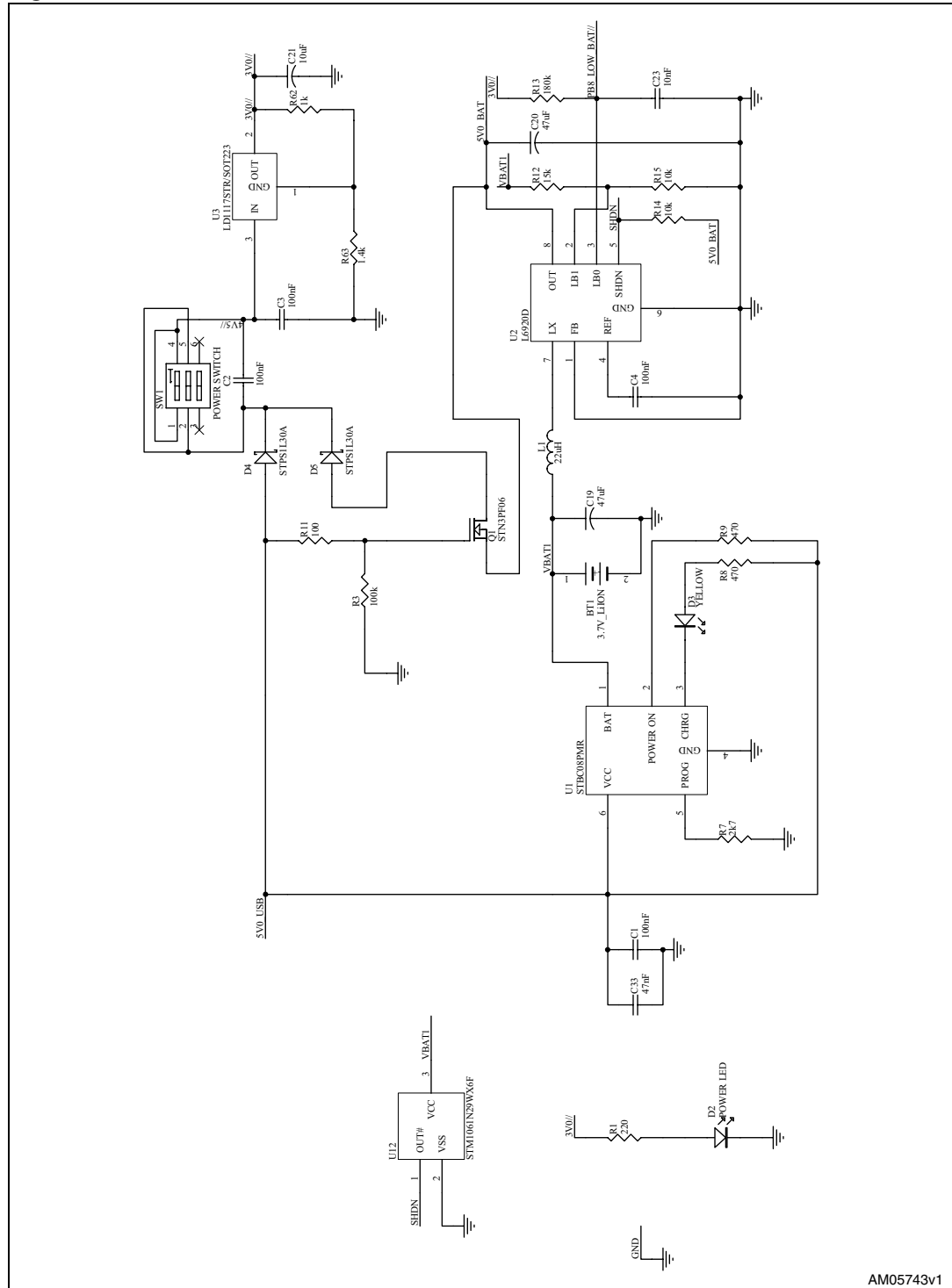
Figure 58. 3 V coin-type CR2032 battery insertion for RTC power backup



7 Schematics and bill of material

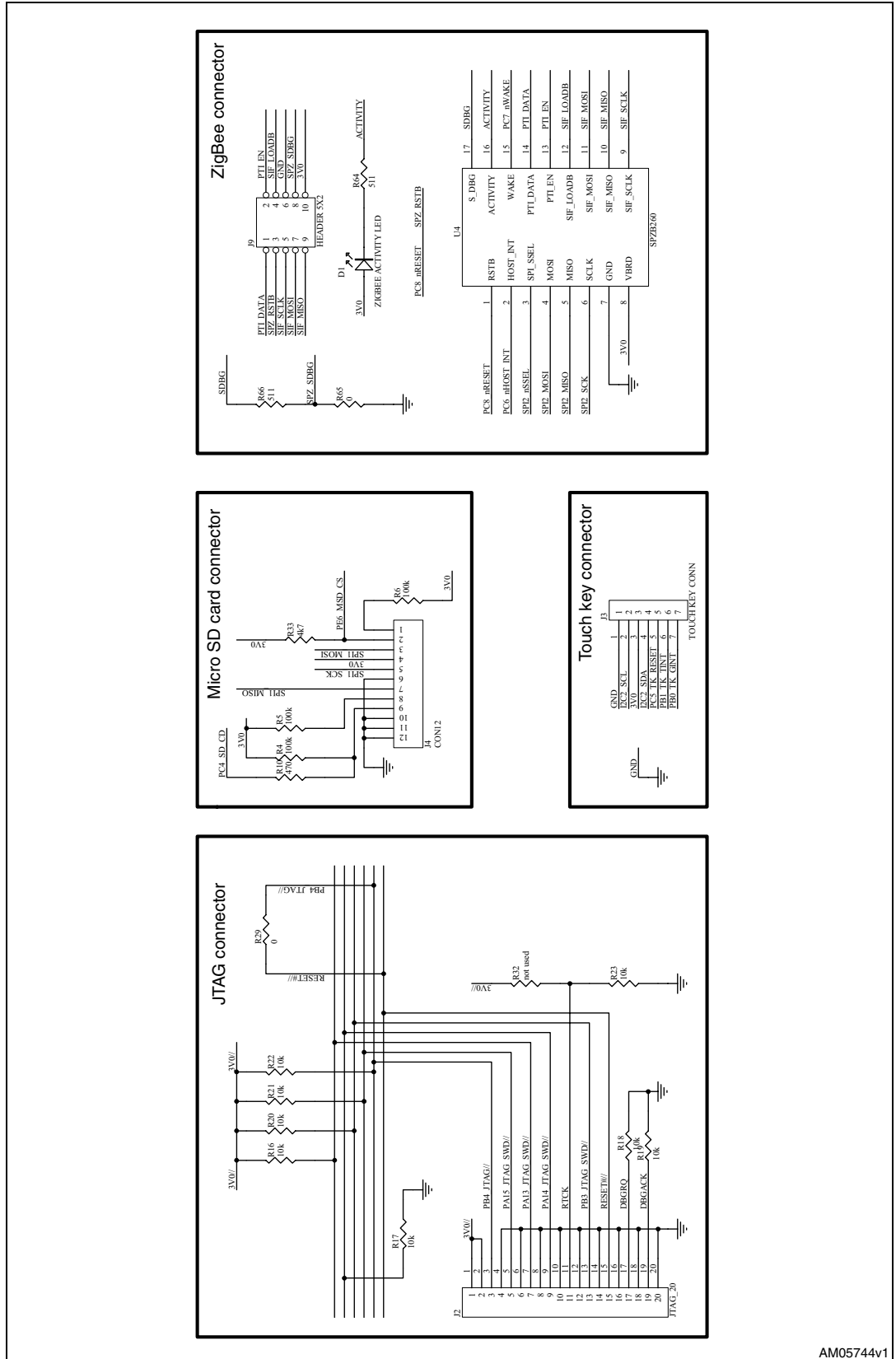
7.1 Schematic and bill of material of STEVAL-IFS014V1

Figure 59. Sheet 1 of schematic of STEVAL-IFS014V1



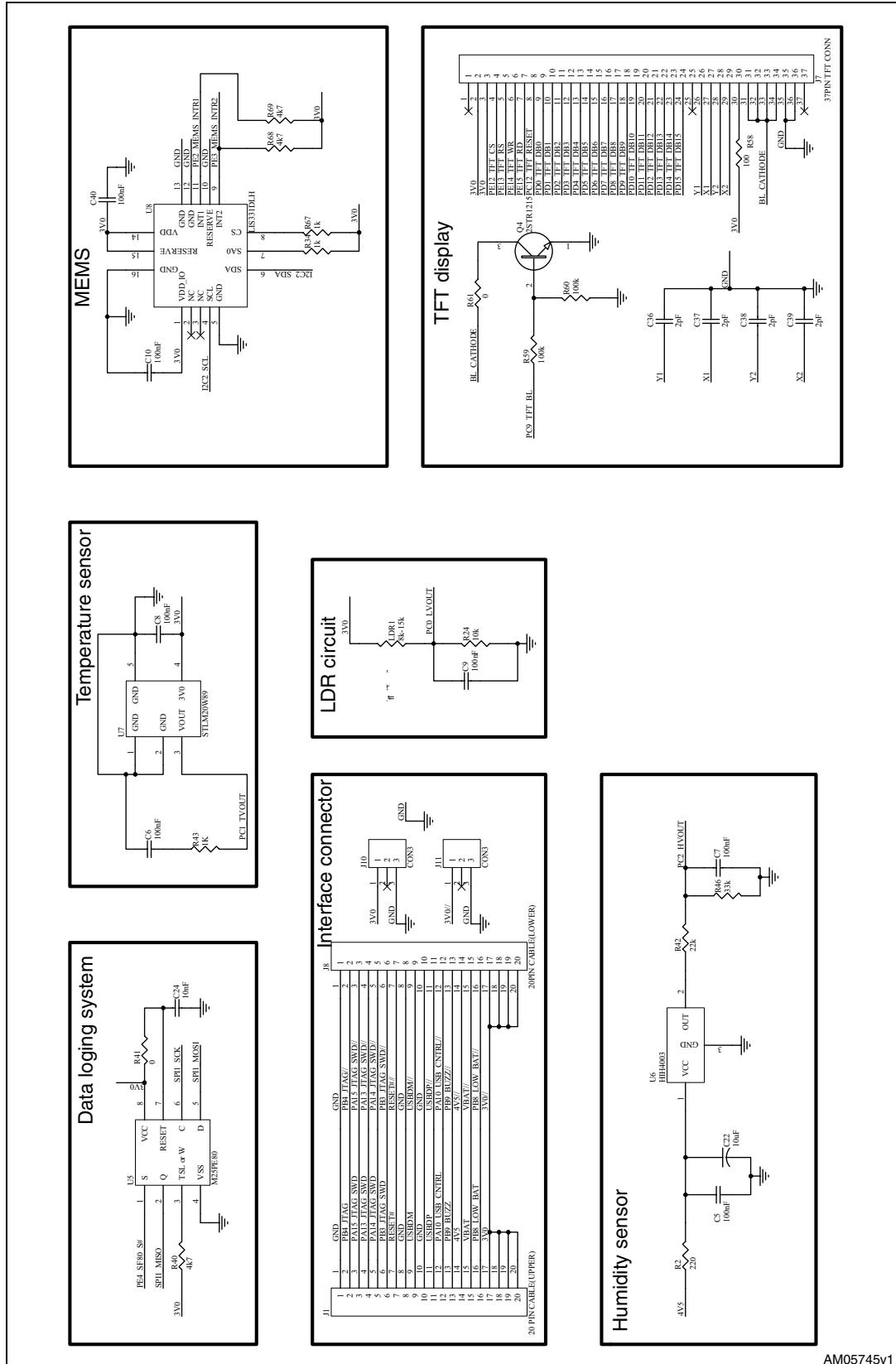
AM05743v1

Figure 60. Sheet 2 of schematic of STEVAL-IFS014V1



AM05744v1

Figure 61. Sheet 3 of schematic of STEVAL-IFS014V1



AM05745v1

Figure 62. Sheet 4 of schematic of STEVAL-IFS014V1

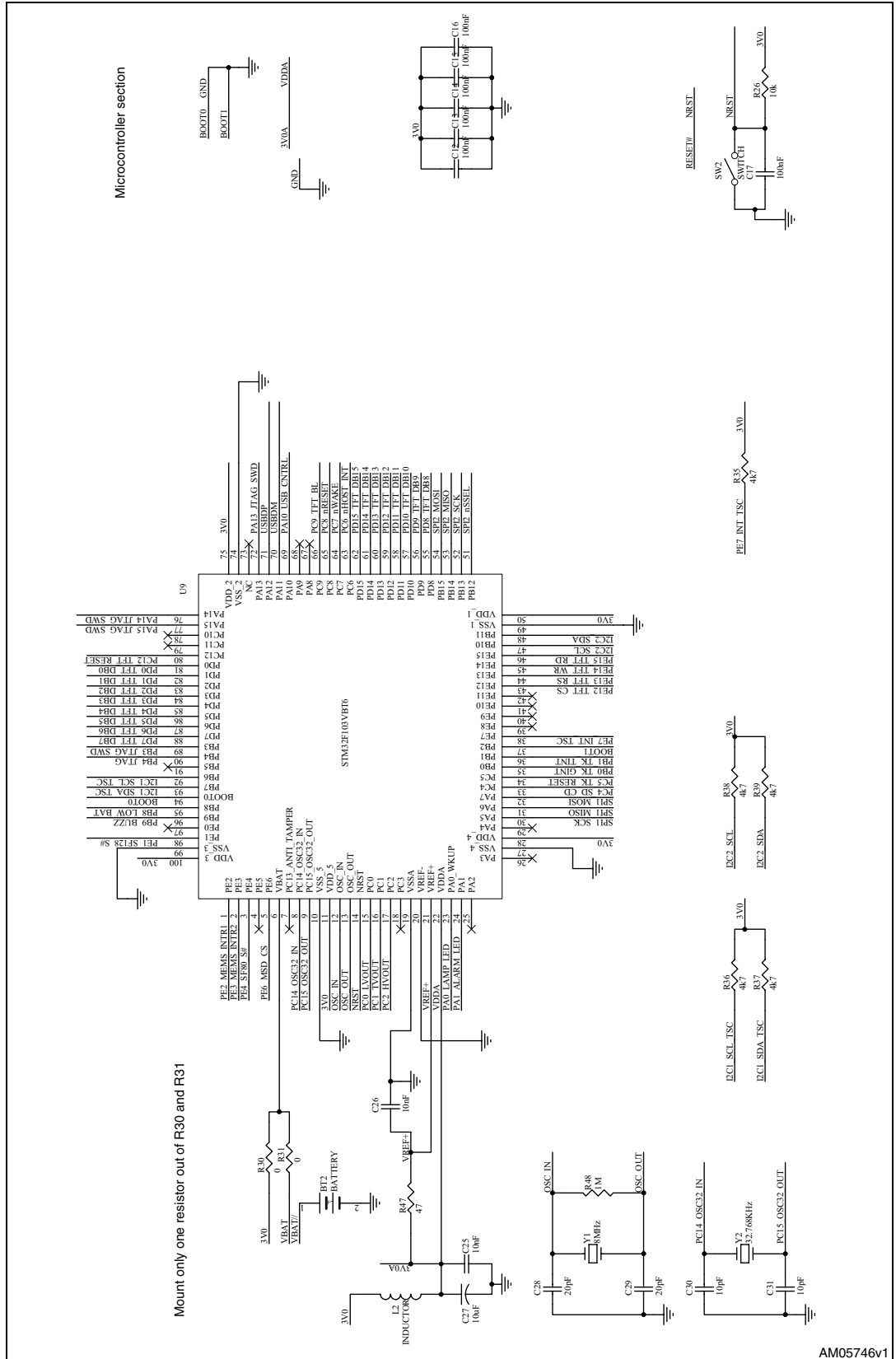
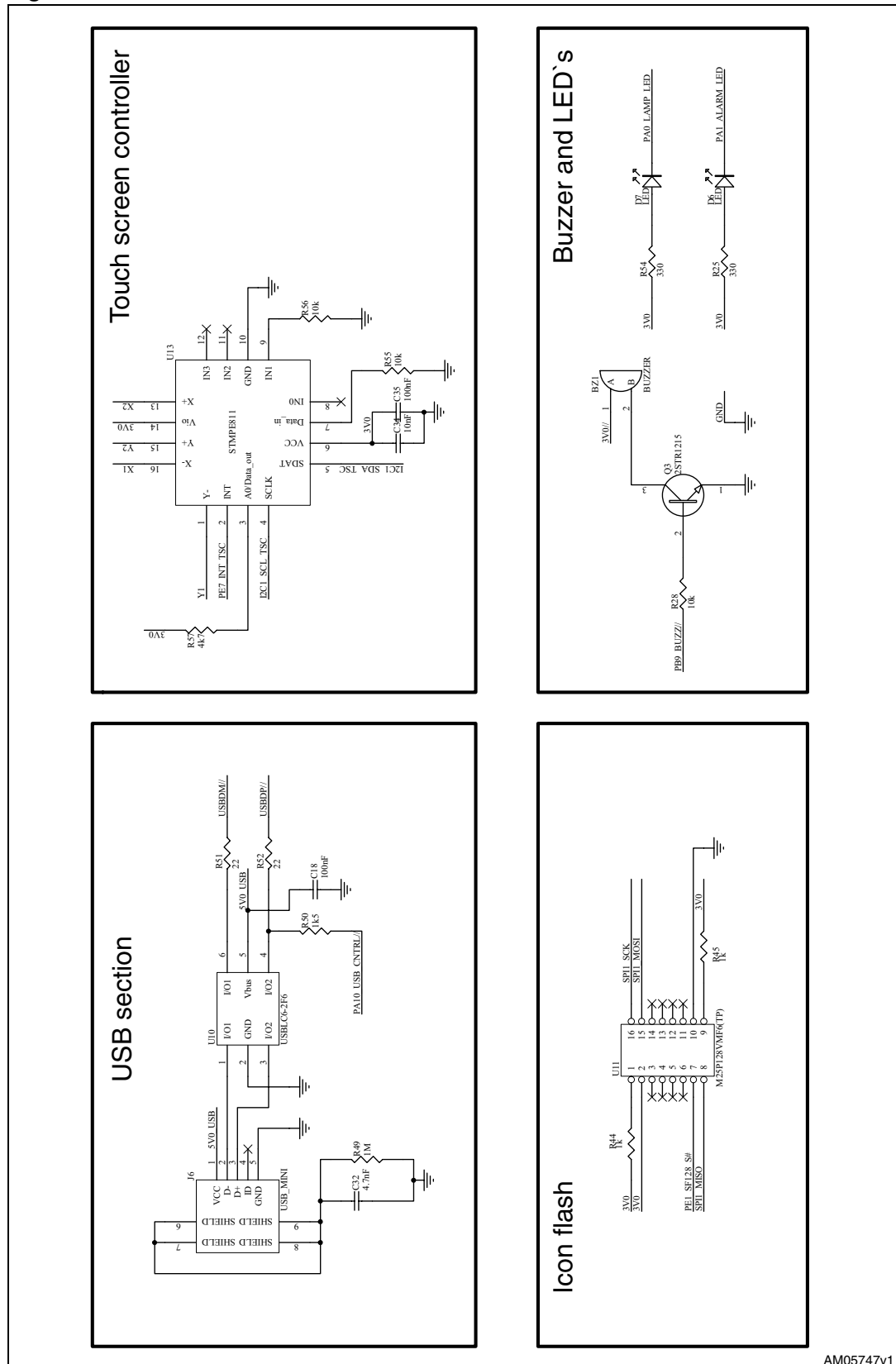


Figure 63. Sheet 5 of schematic of STEVAL-IFS014V1



AM05747v1

**Table 2. Bill of material of STEVAL-IFS014V1**

Category	Ref. des.	Component description	Package	Manuf.	Manufacturer's ordering code / orderable part number	Supplier	Supplier ordering code
ST devices	U1	Battery charger	DFN6	STMicroelectronics	STBC08PMR	STMicroelectronics	STBC08PMR
	U2	Step-up converter	TSSOP8	STMicroelectronics	L6920D	STMicroelectronics	L6920D
	U3	Voltage regulator (3 V output)	SOT- 223	STMicroelectronics	LD1117STR	STMicroelectronics	LD1117STR
	U4	ZigBee module contains SN260 device	SMD	STMicroelectronics	SPZB260	STMicroelectronics	SPZB260
	U5	Serial Flash (1 MB) - used for data logging	SO8W	Numonix	M25PE80-VMW6G	Arrow Electronics	M25PE80-VMW6G
	U7	Temperature sensor (analog)	SOT323-5	STMicroelectronics	STLM20W87F	STMicroelectronics	STLM20W87F
	U8	MEMS	QFPN-28	STMicroelectronics	LIS331DLH	STMicroelectronics	LIS331DLH
	U9	Microcontroller working as host for all the devices connected	LQFP100	STMicroelectronics	STM32F103VBT6	STMicroelectronics	STM32F103VBT6
	U10	USB protection device	SOT-666	STMicroelectronics	USBLC6-2P6	STMicroelectronics	USBLC6-2P6
	U11	Serial Flash (16 MB) - used for pictures storage	SO-16	Numonix	M25P128-VMF6TP	Arrow Electronics	M25P128-VMF6P
	U12	Reset IC	SO8W	STMicroelectronics	STM1061N29WX6F	STMicroelectronics	STM1061N29WX6F
	U13	Touchscreen controller	QFN-16	STMicroelectronics	STMPE811QTR	STMicroelectronics	STMPE811QTR
	D4, D5	Power diode	SMA	STMicroelectronics	STPS1L30A	STMicroelectronics	STPS1L30A
	Q3, Q4	NPN transistor	SOT - 23	STMicroelectronics	2STR1215	STMicroelectronics	2STR1215

Doc ID 16752 Rev 1

51/66

UM0857

Schematics and bill of material

**Table 2. Bill of material of STEVAL-IFS014V1 (continued)**

Category	Ref. des.	Component description	Package	Manuf.	Manufacturer's ordering code / orderable part number	Supplier	Supplier ordering code
	Q1	P-channel power MOSFET	SOT- 223	STMicroelectronics	STN3PF06	STMicroelectronics	STN3PF06
Other Devices	U6	Humidity sensor	Through hole	Honeywell	HIH--4003 or HIH-4000	Dishant Impex	HIH--4003 or HIH-4000
Crystal and Oscillator	Y1	Crystal 8 MHz	Through hole	ABRACON	ABL-8.000MHZ-B2	MOUSER ELECTRONICS	815-ABL-8-B2
	Y2	Crystal 32.768 kHz	Through hole	ABRACON	AB26T-32.768 KHZ	MOUSER ELECTRONICS	815-AB26T-32.768KHZ
Connectors and jumpers	SW2	Tact switch	Through hole	ALPS	SKHHAPA010	MOUSER ELECTRONICS	688-SKHHAP
	SW1	Slide switches DPDT on-on (power on/off)	Through hole	C&K Components	OS202011MA0QN1	MOUSER ELECTRONICS	611-OS202011MA0QN1
	BT2	3V Li-Ion coin battery holder	Through hole	Renata	HU2032-LF	MOUSER ELECTRONICS	614-HU2032-LF
	BT1	Header for 3.7 V Li-Ion battery connection	Through hole	Any			
	J2	JTAG connector	20-pin (pitch 2.54 mm)	3M Electronic Solutions division	30320-6002HB	MOUSER ELECTRONICS	517-30320-6002
	J7	TFT display	SMD connector	AMPIRE Co., LTD	AM240320L7TNQWT0 2H	AMPIRE Co., LTD	AM240320L7TNQWT0 2H
	J6	Mini USB connector	USB mini B-type	Mill-Max Manufacturing Corp.	897-43-005-00-100001	Digi-Key	ED90341CTND
	J4	Micro SD card connector		Proconn technology	MSPN09-X0-1000	Global sources	MSPN09-X0-1000

Doc ID 16752 Rev 1

52/66

UM0857

Schematics and bill of material

**Table 2. Bill of material of STEVAL-IFS014V1 (continued)**

Category	Ref. des.	Component description	Package	Manuf.	Manufacturer's ordering code / orderable part number	Supplier	Supplier ordering code
	J3	Connector for touch key daughterboard	Through-hole, 2.54 mm BergStrip	SAMTEC	TSW-108-23-G-S	Integrated Electronics	TSW-108-23-G-S
	J9	Header for stack updation of ZigBee module SPZB260	SMD	SAMTEC	FTSH-105-01-F-DV-K	Integrated Electronics	FTSH-105-01-F-DV-K
	J1	20-pin cable connector	SMD	SAMTEC	ZF1-20-01-T-WT	Integrated Electronics	ZF1-20-01-T-WT
	J8	20-pin cable connector	SMD	SAMTEC	FC1-20-02-T-WT	Integrated Electronics	FC1-20-02-T-WT
LEDs	D1	Blue LED - ZigBee activity	Through-hole, 3 mm round	Kingbright	WP7104QBC/D	MOUSER ELECTRONICS	604-WP7104QBC/D
	D2	Green LED - power status of the system	Through-hole, 3 mm round	Kingbright	WP7104GC	MOUSER ELECTRONICS	604-WP7104GC
	D3	Orange LED - indication of battery charging ongoing	Through-hole, 3 mm round	Kingbright	WP7104NC	MOUSER ELECTRONICS	604-WP7104NC
	D6	Red LED - alarm signal indicator	Through-hole, 3 mm round	Kingbright	WP7104SRC/D	MOUSER ELECTRONICS	604-WP7104SRC/D
	D7	Yellow LED - lamp	Through-hole, 3 mm round	Kingbright	WP7104YC	MOUSER ELECTRONICS	604-WP7104YC
Capacitors	C36, C37, C38, C39	2 pF	SMD0805	Any			
	C30, C31	10 pF	SMD0805	Any			
	C28, C29,	20 pF	SMD0805	Any			

Doc ID 16752 Rev 1

53/66

UM0857

Schematics and bill of material


Table 2. Bill of material of STEVAL-IFS014V1 (continued)

Category	Ref. des.	Component description	Package	Manuf.	Manufacturer's ordering code / orderable part number	Supplier	Supplier ordering code
	C32	4.7 nF	SMD0805	Any			
	C23, C24, C25, C26, C34	10 nF	SMD0805	Any			
	C33	47 nF					
	C1, C2, C3, C4, C5, C6, C7, C8, C9, C10, C11, C12, C13, C14, C15, C16, C17, C18, C35, C40	100 nF	SMD0805	Any			
	C21, C22, C27,	Tantalum cap 10 μ F	SMD1206	Rohm semiconductor	TCA1A106M8R	Digi-Key	511-1463-1-ND
	C19, C20	Tantalum cap 47 μ F	SMD1206				
Inductors	L1	22 μ H (630 MA)	SMD (6.0 mm x 6.0 mm x 1.2 mm) (L x W x H)	Taiyo Yuden	NR6012T220M	Digi-Key	587-1708-1-ND
	L2	1 μ H (reactance 600 at 100 MHz)	SMD0805	MuRata	BLM21B601S	Digi-Key	490-1046-1-ND
Resistors	R29, R30, R31, R32, R41, R61, R65	0	SMD0805	Any			
	R51, R52	22 Ω	SMD0805	Any			
	R47	47 Ω	SMD0805	Any			
	R11, R58	100 Ω	SMD0805	Any			
	R1, R2	220 Ω	SMD0805	Any			
	R25, R54	330 Ω	SMD0805	Any			

**Table 2. Bill of material of STEVAL-IFS014V1 (continued)**

Category	Ref. des.	Component description	Package	Manuf.	Manufacturer's ordering code / orderable part number	Supplier	Supplier ordering code
	R8, R9, R10	470 Ω	SMD0805	Any			
	R64, R66	511 Ω	SMD0805	Any			
	R34, R43,R44,R45, R62, R67	1 k Ω	SMD0805	Any			
	R50, R63	1.5 k Ω	SMD0805	Any			
	R7	2.7 k Ω	SMD0805	Any			
	R33, R35, R36, R37, R38, R39, R40, R57, R68, R69	4.7 k Ω	SMD0805	Any			
	R14,R15, R16, R17, R18, R19, R20, R21, R22, R23, R24, R26,R28, R55, R56	10 k Ω	SMD0805	Any			
	R12	15 k Ω	SMD0805	Any			
	R46	33 k Ω	SMD0805	Any			
	R3, R4, R5, R6, R59, R60	100 k Ω	SMD0805	Any			
	R13	180 k Ω	SMD0805	Any			
	R48, R49	1 M Ω	SMD0805	Any			
Misc. components	BZ1	Buzzer	AXIAL	CUI Inc	CEP-2242	Digi-Key	102-1115-ND
	LDR 1	Light-dependant resistor	Through-hole	Advanced Photonix Inc	PDV-P5001	Digi-Key	PDV-P5001-ND

Doc ID 16752 Rev 1

55/66

UM0857

Schematics and bill of material

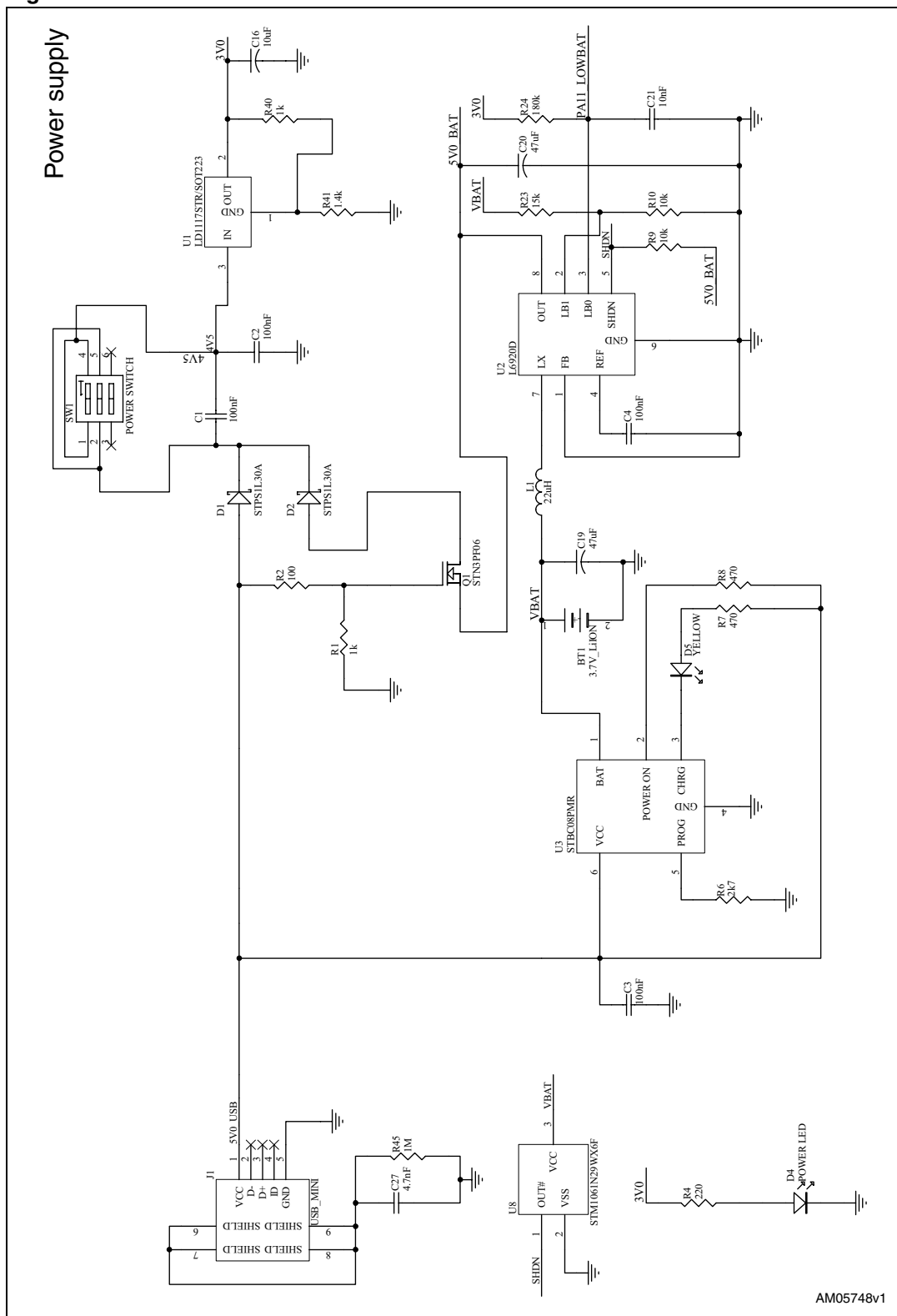
Table 2. Bill of material of STEVAL-IFS014V1 (continued)

Category	Ref. des.	Component description	Package	Manuf.	Manufacturer's ordering code / orderable part number	Supplier	Supplier ordering code
	-	Cable to connect J1 and J8 after breakup of the board	-	Samtec	FJ-20-D-03.00-4	Integrated Electronics	FJ-20-D-03.00-4
			Casing	OKW	A9052107 and A952017 and A9152007	Schurter Electronics (India)	A9052107 and A952017 and A9152007

- Note:*
- 1 *Out of R30 and R31 only one resistor is to be mounted*
 - 2 *R32 is not to be mounted.*
 - 3 *Components SW2, BT1, J3, J4 and J9 are not mounted.*

7.2 Schematic and bill of material of STEVAL-IFS015V1

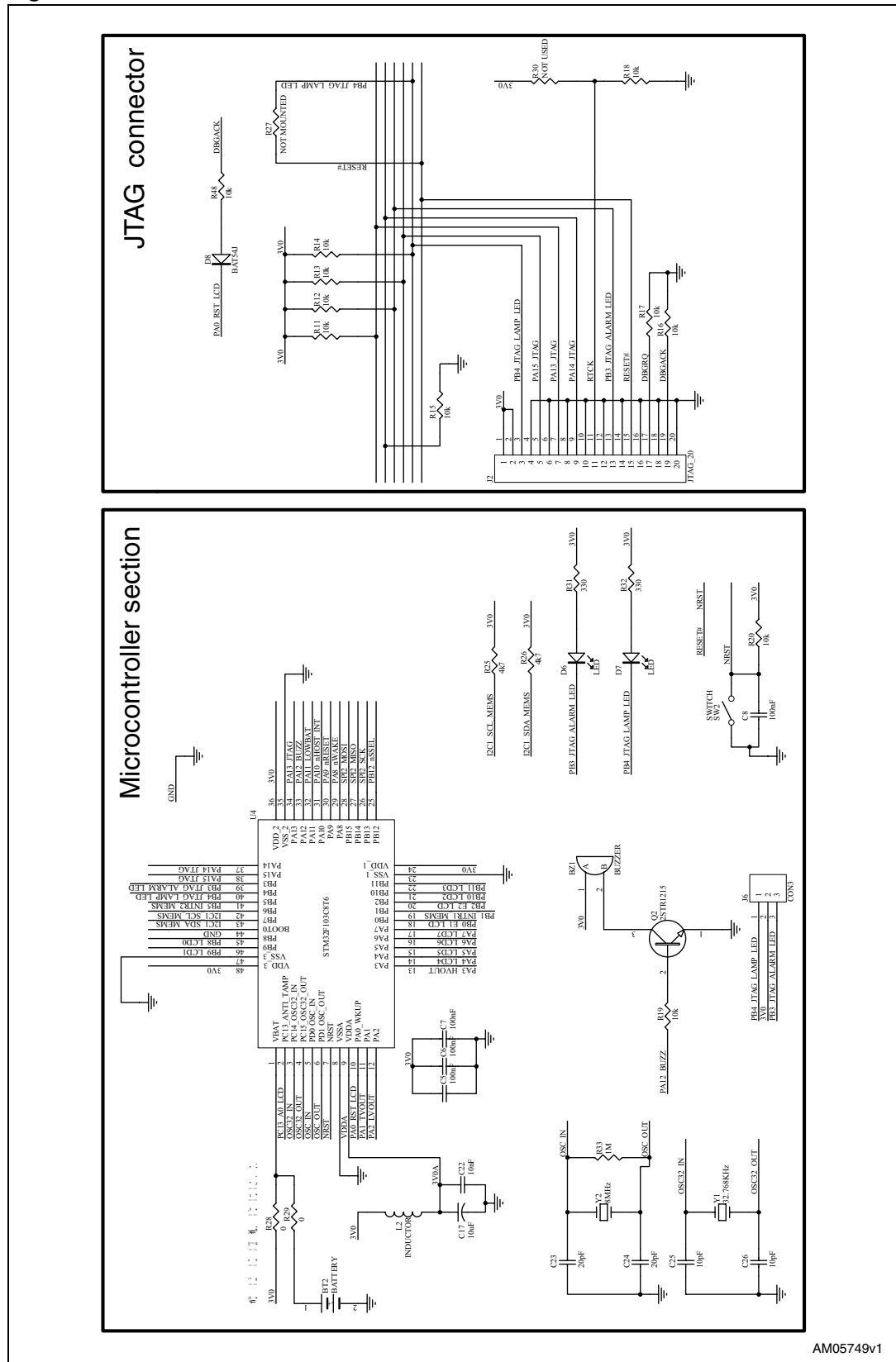
Figure 64. Sheet 1 of schematic of STEVAL-IFS015V1



AM05748v1

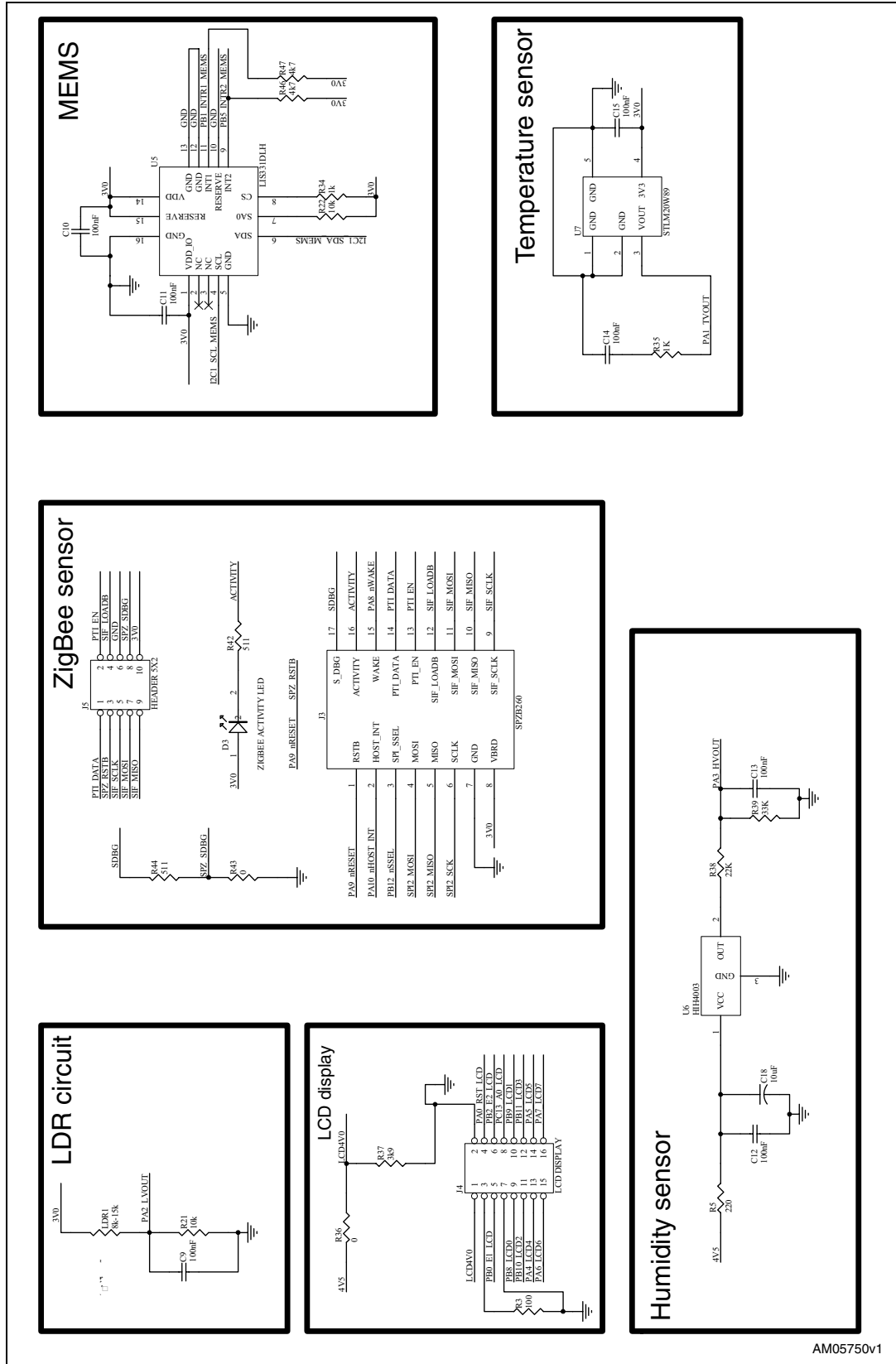


Figure 65. Sheet 2 of schematic of STEVAL-IFS015V1



AM05749v1

Figure 66. Sheet 3 of schematic of STEVAL-IFS015V1



AM05750v1

**Table 3. Bill of material of STEVAL-IFS015V1**

Category	Ref. des.	Component description	Package	Manuf.	Manufacturer's ordering code / orderable part number	Supplier	Supplier ordering code
ST devices	U1	Voltage regulator (3 V output)	SOT- 223	STMicroelectronics	LD1117STR	STMicroelectronics	LD1117STR
	U2	Step-up converter	TSSOP8	STMicroelectronics	L6920D	STMicroelectronics	L6920D
	U3	Battery charger	DFN6	STMicroelectronics	STBC08PMR	STMicroelectronics	STBC08PMR
	U4	Microcontroller working as host for all the devices connected	LQFP48 (7 X 7)	STMicroelectronics	STM32F103C8T6	STMicroelectronics	STM32F103C8T6
	U5	MEMS	QFPN-16	STMicroelectronics	LIS331DLH	STMicroelectronics	LIS331DLH
	U7	Temperature sensor (analog)	SOT323-5	STMicroelectronics	STLM20W87F	STMicroelectronics	STLM20W87F
	U8	Low-voltage detector	SOT23-3	STMicroelectronics	STM1061N29WX6F	STMicroelectronics	STM1061N29WX6F
	J3	ZigBee module contains SN260 device	SMD	STMicroelectronics	SPZB260	STMicroelectronics	SPZB260
	D1,D2	Power diode	SMA	STMicroelectronics	STPS1L30A	STMicroelectronics	STPS1L30A
	Q2	NPN transistor	SOT - 23	STMicroelectronics	2STR1215	STMicroelectronics	2STR1215
	Q1	P-channel power MOSFET	SOT- 223	STMicroelectronics	STN3PF06	STMicroelectronics	STN3PF06
D8	Schottky diode	SMD	STMicroelectronics	BAT54JFILM	STMicroelectronics	BAT54JFILM	
Other devices	U6	Humidity sensor	Through-hole	Honey - Well	HIH--4003 or HIH-4000	Dishant Impex	HIH--4003 or HIH-4000
Crystal and oscillator	Y1	Crystal 8 MHz	Through-hole	ABRACON	ABL-8.000MHZ-B2	MOUSER ELECTRONICS	815-ABL-8-B2
	Y2	Crystal 32.768 kHz	Through-hole	ABRACON	AB26T-32.768KHZ	MOUSER ELECTRONICS	815-AB26T-32.768 kHz

Doc ID 16752 Rev 1

60/66

UM0857

Schematics and bill of material

**Table 3. Bill of material of STEVAL-IFS015V1 (continued)**

Category	Ref. des.	Component description	Package	Manuf.	Manufacturer's ordering code / orderable part number	Supplier	Supplier ordering code
Connectors and jumpers	SW2	Tact switch	Through-hole	ALPS	SKHHAPA010	MOUSER ELECTRONICS	688-SKHHAP
	SW1	Slide switches DPDT on-on (power on/off)	Through-hole	C&K Components	OS202011MA0QN1	MOUSER ELECTRONICS	611-OS202011MA0QN1
	BT2	3 V Li-Ion coin battery holder	Through-hole	Renata	HU2032-LF	MOUSER ELECTRONICS	614-HU2032-LF
	BT1	Header for 3.7 V Li-Ion Battery Connection	Through-hole	Any			
	J1	Mini USB connector	USB Mini B-Type	Mill-Max Manufacturing Corp.	897-43-005-00-100001	Digikey	ED90341CTND
	J5	Header for stack updatation of ZigBee module SPZB260	SMD	SAMTEC	FTSH-105-01-F-DV-K	Integerated Electronics	FTSH-105-01-F-DV-K
	J2	JTAG connector	20-pin (pitch 2.54 mm)	3M electronic solutions division	30320-6002HB	MOUSER ELECTRONICS	517-30320-6002
	J4 (please see the Note 1 also)	Connector to solder on the graphical display (please see Note 2)	Header 16-pin , 2.54 mm pitch	SAMTEC	TSW-150-23-G-S	Integerated Electronics	TSW-150-23-G-S
	J6	Connector to take lamp LED and alarm signal out of the PCB	Header 16-pin , 2.54 mm pitch	SAMTEC	TSW-150-23-G-S	Integerated Electronics	TSW-150-23-G-S
LEDs	D3	Blue LED - ZigBee activity	Through-hole, 3 mm round	Kingbright	WP7104QBC/D	MOUSER ELECTRONICS	604-WP7104QBC/D
	D4	Green LED - power status of the system	Through-hole, 3 mm round	Kingbright	WP7104GC	MOUSER ELECTRONICS	604-WP7104GC
	D5	Orange LED - indication of battery charging ongoing	Through-hole, 3 mm round	Kingbright	WP7104NC	MOUSER ELECTRONICS	604-WP7104NC

Doc ID 16752 Rev 1

61/66

UM0857

Schematics and bill of material


Table 3. Bill of material of STEVAL-IFS015V1 (continued)

Category	Ref. des.	Component description	Package	Manuf.	Manufacturer's ordering code / orderable part number	Supplier	Supplier ordering code
LEDs	D6	Red LED - alarm signal indicator	Through-hole, 3 mm round	Kingbright	WP7104SRC/D	MOUSER ELECTRONICS	604-WP7104SRC/D
	D7	Yellow LED - lamp	Through-hole, 3 mm round	Kingbright	WP7104YC	MOUSER ELECTRONICS	604-WP7104YC
Capacitors	C25,C26	10 pF	SMD0402	Any			
	C23,C24	20 pF	SMD0402	Any			
	C27	4.7 nF	SMD0402	Any			
	C21,C22	10 nF	SMD0402	Any			
	C1,C2,C3, C4,C5,C6, C7,C8,C9, C10,C11, C12,C13, C14,C15	100 nF	SMD0402	Any			
	C19,C20	47 μ F	SMD0402	Any			
	C16, C17, C18	Tantalum cap 10 μ F	SMD1206	R Ω semiconductor	TCA1A106M8R	Digi-Key	511-1463-1-ND
Inductors	L1	22 μ H (630 MA)	SMD (6.0 mm x 6.0 mm X 1.2 mm) (L X W X H)	Taiyo Yuden	NR6012T220M	Digi-Key	587-1708-1-ND
	L2	1 μ H (Reactance 600 at 100 MHz)	SMD0805	Murata	BLM21B601S	Digi-Key	490-1046-1-ND
Resistors	R27, R28, R29, R30, R36, R43	0	SMD0402	Any			
	R2, R3	100 Ω	SMD0402	Any			
	R4, R5	220 Ω	SMD0402	Any			

**Table 3. Bill of material of STEVAL-IFS015V1 (continued)**

Category	Ref. des.	Component description	Package	Manuf.	Manufacturer's ordering code / orderable part number	Supplier	Supplier ordering code
Resistors	R31, R32	330 Ω	SMD0402	Any			
	R7, R8	470 Ω	SMD0402	Any			
	R42, R44	511 Ω	SMD0402	Any			
	R1, R34, R35, R40	1 kΩ	SMD0402	Any			
	R41	1.4 kΩ	SMD0402	Any			
	R6	2.7 kΩ	SMD0402	Any			
	R37	3.9 kΩ	SMD0402	Any			
	R25, R26, R46, R47	4.7 kΩ	SMD0402	Any			
	R9, R10, R11, R12, R13, R14, R15, R16, R17, R18, R19, R20, R21, R22, R48,	10 kΩ	SMD0402	Any			
	R23	15 kΩ	SMD0402	Any			
	R38	22 kΩ	SMD0402	Any			
	R39	33 kΩ	SMD0402	Any			
	R24	180 kΩ	SMD0402	Any			
R33, R45	1 MΩ	SMD0402	Any				
Misc components	BZ1	Buzzer	AXIAL	CUI Inc	CEP-2242	Digi-Key	102-1115-ND
	LDR 1	Light-dependant resistor	Through-hole	Advanced Photonix Inc	PDV-P5001	Digi-Key	PDV-P5001-ND

Doc ID 16752 Rev 1

63/66

UM0857

Schematics and bill of material

Table 3. Bill of material of STEVAL-IFS015V1 (continued)

Category	Ref. des.	Component description	Package	Manuf.	Manufacturer's ordering code / orderable part number	Supplier	Supplier ordering code
Misc components		Graphical LCD display	PCB	TechStar	TS12232C	Shenzhen Techstar Electronics	TS12232C
		Header for graphical LCD	Header 16-pin , 2.54 mm pitch	Samtec	SSQ-108-01-G-D	Integrated Electronics	SSQ-108-01-G-D
		Support for graphical display	1-pin mail berg strip	Samtec	TSW-150-17-G-S	Integrated Electronics	TSW-150-17-G-S
		LED spacer	3 mm	Keystone Electronics	8917	MOUSER ELECTRONICS	534-8917
		LED spacer for LDR	3 mm	Keystone Electronics	8914	MOUSER ELECTRONICS	534-8914
			Case	OKW	A9051107 and A952047 and A9151017	Schurter Electronics (India)	A9051107 and A952047 and A9151017

- Note:**
- 1 Header J4 is the male BergStrip which is cut to size and soldered on the PCB. This is used to connect the PCB with the graphical display. Please see serial part no. - 58, 59 and 60.
 - 2 This is the female Berg Strip which is soldered on the Graphical Display TS12232C, so that the display can be attached on the PCB through J4
 - 3 Out of R28 and R29, only one to be mounted.
 - 4 R27 and R39 are not to be mounted.
 - 5 Components SW2, BT1, J5 and J6 are not mounted.

8 Revision history

Table 4. Document revision history

Date	Revision	Changes
04-Jan-2010	1	Initial release

Please Read Carefully:

Information in this document is provided solely in connection with ST products. STMicroelectronics NV and its subsidiaries ("ST") reserve the right to make changes, corrections, modifications or improvements, to this document, and the products and services described herein at any time, without notice.

All ST products are sold pursuant to ST's terms and conditions of sale.

Purchasers are solely responsible for the choice, selection and use of the ST products and services described herein, and ST assumes no liability whatsoever relating to the choice, selection or use of the ST products and services described herein.

No license, express or implied, by estoppel or otherwise, to any intellectual property rights is granted under this document. If any part of this document refers to any third party products or services it shall not be deemed a license grant by ST for the use of such third party products or services, or any intellectual property contained therein or considered as a warranty covering the use in any manner whatsoever of such third party products or services or any intellectual property contained therein.

UNLESS OTHERWISE SET FORTH IN ST'S TERMS AND CONDITIONS OF SALE ST DISCLAIMS ANY EXPRESS OR IMPLIED WARRANTY WITH RESPECT TO THE USE AND/OR SALE OF ST PRODUCTS INCLUDING WITHOUT LIMITATION IMPLIED WARRANTIES OF MERCHANTABILITY, FITNESS FOR A PARTICULAR PURPOSE (AND THEIR EQUIVALENTS UNDER THE LAWS OF ANY JURISDICTION), OR INFRINGEMENT OF ANY PATENT, COPYRIGHT OR OTHER INTELLECTUAL PROPERTY RIGHT.

UNLESS EXPRESSLY APPROVED IN WRITING BY AN AUTHORIZED ST REPRESENTATIVE, ST PRODUCTS ARE NOT RECOMMENDED, AUTHORIZED OR WARRANTED FOR USE IN MILITARY, AIR CRAFT, SPACE, LIFE SAVING, OR LIFE SUSTAINING APPLICATIONS, NOR IN PRODUCTS OR SYSTEMS WHERE FAILURE OR MALFUNCTION MAY RESULT IN PERSONAL INJURY, DEATH, OR SEVERE PROPERTY OR ENVIRONMENTAL DAMAGE. ST PRODUCTS WHICH ARE NOT SPECIFIED AS "AUTOMOTIVE GRADE" MAY ONLY BE USED IN AUTOMOTIVE APPLICATIONS AT USER'S OWN RISK.

Resale of ST products with provisions different from the statements and/or technical features set forth in this document shall immediately void any warranty granted by ST for the ST product or service described herein and shall not create or extend in any manner whatsoever, any liability of ST.

ST and the ST logo are trademarks or registered trademarks of ST in various countries.

Information in this document supersedes and replaces all information previously supplied.

The ST logo is a registered trademark of STMicroelectronics. All other names are the property of their respective owners.

© 2010 STMicroelectronics - All rights reserved

STMicroelectronics group of companies

Australia - Belgium - Brazil - Canada - China - Czech Republic - Finland - France - Germany - Hong Kong - India - Israel - Italy - Japan - Malaysia - Malta - Morocco - Philippines - Singapore - Spain - Sweden - Switzerland - United Kingdom - United States of America

www.st.com