**STEVAL-PCC012V1 STM32F107xx connectivity gateway,
demonstration board**

1 Introduction

This user manual describes the implementation of the STEVAL-PCC012V1 demonstration board. The STEVAL-PCC012V1 demonstration board is equipped with an Ethernet interface, four digital/analog extension connectors (I²C, SPI, etc.), two footprint positions for two different Wi-Fi modules, an OFDM PRIME power line networking extension connector and a microSD™ Card socket with SPI interface. It also features a 5-way general purpose joystick, four general purpose LEDs and two LEDs dedicated to user interface.

The demonstration board also includes digital/analog input/output connectors pinout compatible with existing demonstration boards from STMicroelectronics™:

- STEVAL-CCA021V1 - audio demonstration board (stereo DAC, Class-D amplifier)
- STEVAL-MK10xxV1 - MEMS demonstration boards (gyroscope, accelerometer) that are compatible with 24 DIL socket
- EVALST7590-1 - ST7590 “PRIME” board - narrow-band OFDM power line networking PRIME compliant system-on-chip.

The demonstration board can be supplied from a standard DC power supply (7 - 35 V DC) or directly using a 24 V DC industrial mains supply.

Figure 1. STEVAL-PCC012V1



Contents

- 1 Introduction 1**
- 2 STEVAL-PCC012V1 key features 6**
 - 2.1 Order code 7
- 3 Block diagram 8**
- 4 Demonstration board layout 9**
- 5 Configuration 10**
 - 5.1 Ethernet 10
 - 5.2 Power supply 11
 - 5.3 General purpose 5-way joystick SW1 12
 - 5.4 LEDs 12
 - 5.5 SPI bus communication 12
 - 5.6 I²C, USART signals branching for MEMS, Wi-Fi, digital audio and PLM 13
 - 5.7 Analog signals branching for MEMS 14
 - 5.8 Clock source setting 14
 - 5.9 Reset button 14
 - 5.10 USB-OTG configuration 15
 - 5.11 MicroSD Card 15
 - 5.12 Wi-Fi optional modules 16
 - 5.12.1 Wi-Fi optional module-1 U9 settings 16
 - 5.12.2 Wi-Fi optional module-2 U10 settings and signal description 16
- 6 Connectors 17**
 - 6.1 JTAG connector CN1 17
 - 6.2 Audio extension connector CN3 17
 - 6.3 Analog/digital MEMS extension connector CN6 and CN8 18
 - 6.4 Power line networking extension connector CN7 20
 - 6.5 Power test points 21
 - 6.6 USB connector CN4 21

6.7	U10 Wi-Fi module-2 debugging signals TXupd and RXupd	22
6.8	Ethernet RJ45 connectors CN5	22
6.9	MicroSD Card connector CN9	22
6.10	Schematics	24
6.11	Power supply connectors CN2, P2	36
7	Evaluation software	37
7.1	Connectivity Gateway demonstration application (CG demonstration)	37
8	BOM of the board	39
9	Revision history	42

List of tables

Table 1.	Order code	7
Table 2.	Default configuration of the Ethernet PHY	10
Table 3.	Ethernet PHY configuration defined by SB1, SB2 and SB3	10
Table 4.	Logical levels on CFG0, CFG1	11
Table 5.	Ethernet PHY configuration defined by CFG0, CFG1	11
Table 6.	U2 DC/DC converter jumpers	11
Table 7.	Joystick direction mapping	12
Table 8.	LED mapping	12
Table 9.	MEMS, Wi-Fi, PLM I ² C and USART signals branching	13
Table 10.	Digital audio I ² C branching	13
Table 11.	Analog signals branching of STM32 pins PA6 and PA7 to analog MEMS	14
Table 12.	Clock source setting	14
Table 13.	USB-OTG configuration	15
Table 14.	Optional Wi-Fi modules configuration	16
Table 15.	Wi-Fi optional module-1 U9 settings	16
Table 16.	Wi-Fi optional module-2 U10 settings and signal description	16
Table 17.	JTAG connector signals	17
Table 18.	Description of the I ² S audio connector pins of the TS4657 audio card	18
Table 19.	Digital MEMS connector signals	19
Table 20.	GPIO and analog MEMS connector signals	20
Table 21.	Connector CN7 for PLM, USART and SPI interface	20
Table 22.	Test points	21
Table 23.	USB connector CN4 signals	21
Table 24.	U10 Wi-Fi module-2 debugging signals TXupd and RXupd	22
Table 25.	RJ45 connectors CN5	22
Table 26.	MicroSD Card connector CN9	23
Table 27.	Power supply connector CN2	36
Table 28.	Power supply connector P2	36
Table 29.	Board function indication after reset for server/clients example	38
Table 30.	Bill of material	39
Table 31.	Document revision history	42

List of figures

Figure 1. STEVAL-PCC012V1 1

Figure 2. STEVAL-CCA021V1 6

Figure 3. STEVAL-MKI0xxV1 7

Figure 4. Block diagram of STEVAL-PCC012V1 8

Figure 5. STEVAL-PCC012V1 - connector map 9

Figure 6. SD Card formats 15

Figure 7. JTAG connector pinout 17

Figure 8. I²S audio connector of the TS4657 audio card - schematic 17

Figure 9. Digital MEMS connector pinout 18

Figure 10. GPIO and analog connector pinout 19

Figure 11. Connector CN7 for PLM, USART and SPI interface 20

Figure 12. Ethernet RJ45 connectors CN5 - front view 22

Figure 13. MicroSD Card connector CN9 22

Figure 14. Power supply 24

Figure 15. STM32 - part 1(inputs, outputs, clock, reset) 25

Figure 16. STM32 - part 2 (JTAG, LEDs, audio extension connector) 26

Figure 17. STM32 - part 3 (joystick, analog decoupling, DAC_FMT signals) 27

Figure 18. Ethernet - part 1 (PHY pinout) 28

Figure 19. Ethernet - part 2 (overvoltage protection, PHY configuration) 29

Figure 20. Ethernet - part 3 (magnetics) 30

Figure 21. USB-OTG 31

Figure 22. Wi-Fi module-1 32

Figure 23. Wi-Fi module-2 33

Figure 24. MicroSD Card 34

Figure 25. MEMS extension connectors 35

Figure 26. Power supply connector CN2 36

Figure 27. Power supply connector P2 36

Figure 28. Connectivity Gateway Webserver demonstration 38

2 STEVAL-PCC012V1 key features

- 1 x Ethernet RJ45 connectors (ST802RT1A)
- USB-OTG with 0.5 A onboard power supply
- General purpose extension connector with GPIOs, ADC, I²C, SPI
- DC/DC converter L7986A (+24 V / +5 V)
- MicroSD Card™ socket
- Two positions for optional Wi-Fi modules
- 4 + 2 LEDs, 5-way general purpose joystick and system reset button
- Digital/analog extension connectors compatible with STEVAL-MK10xxV1
- Digital/analog extension connectors compatible with STEVAL-CCA021V1
- Extension connector for ST7590 “PRIME” board - narrow-band OFDM power line networking PRIME compliant system-on-chip.

Figure 2. STEVAL-CCA021V1

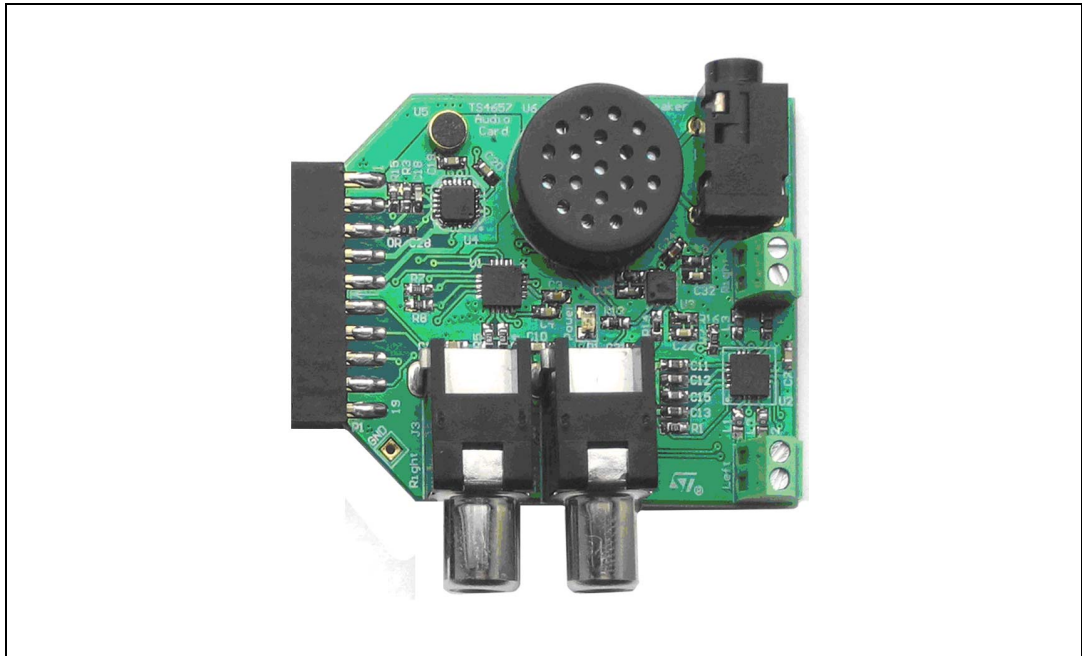

Figure 3. STEVAL-MKI0xxV1



Refer to user manual UM0722 for details on how to use the STEVAL-CCA021V1.

2.1 Order code

Table 1. Order code

Part number	Note
STEVAL-PCC012V1	STM32F107xx connectivity gateway
STEVAL-CCA021V1	Audio demonstration board (stereo DAC, Class-D amplifier)

3 Block diagram

Figure 4. Block diagram of STEVAL-PCC012V1

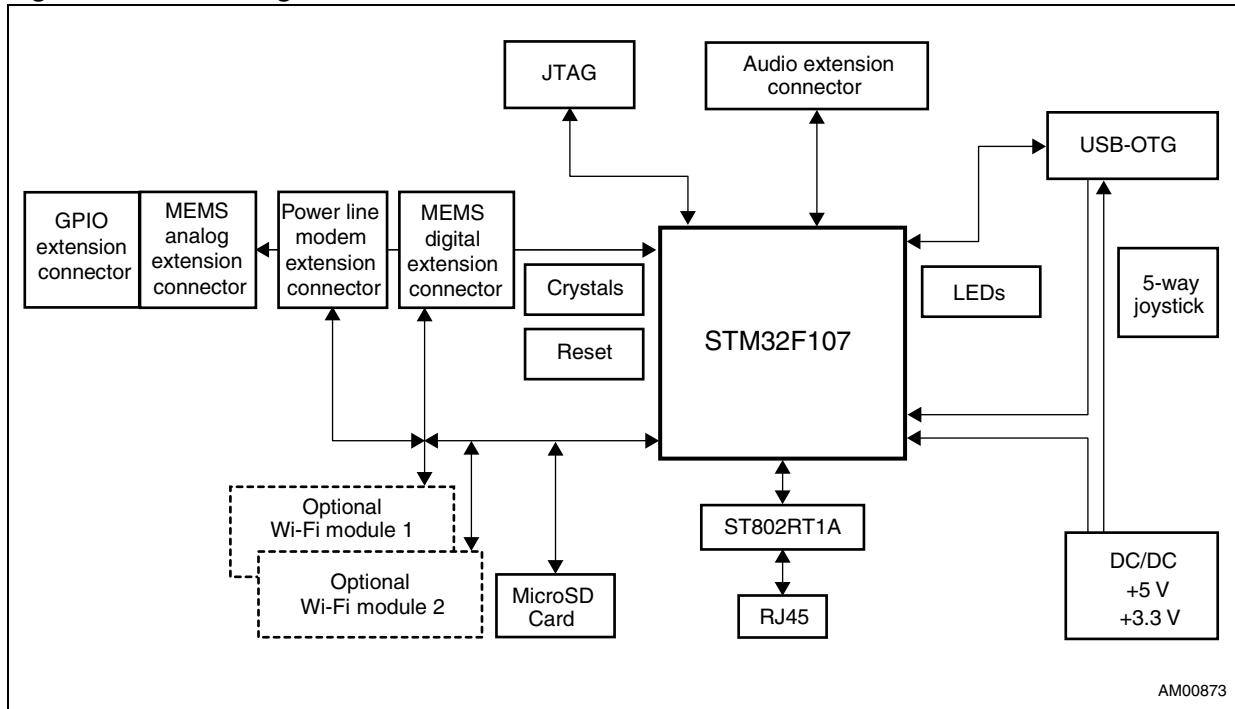

4 Demonstration board layout

Figure 5. STEVAL-PCC012V1 - connector map

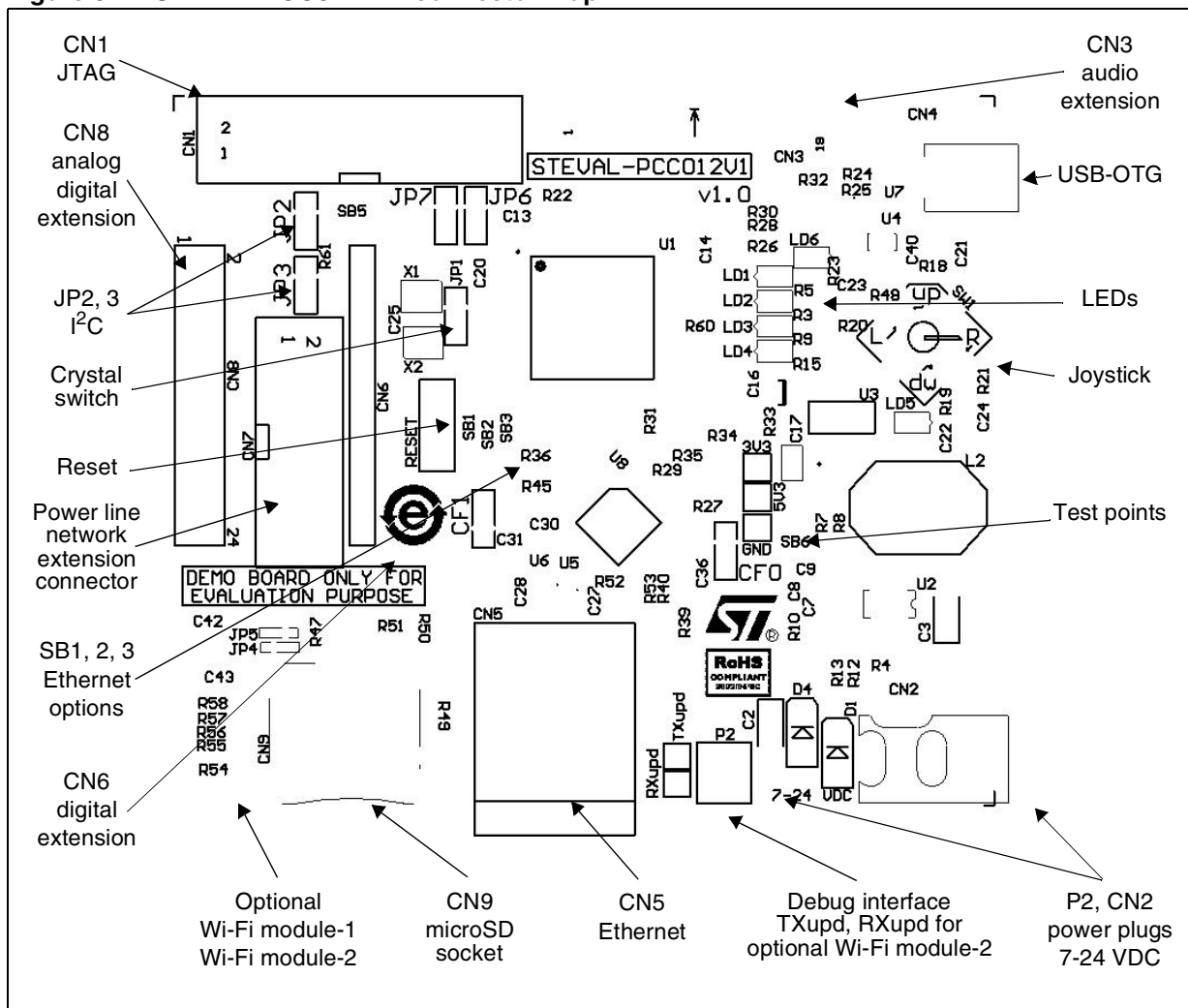

5 Configuration

5.1 Ethernet

An Ethernet PHY U5 is available on the board. It is connected through the media independent interfaces (MII, and reduced MII, RMII) to the Ethernet MACs of the STM32™ microcontroller.

If the Ethernet PHY is used, the crystal resonator X2 must be chosen as STM32 clock source.

The clock source for the PHY is the clock output MCO signal of the STM32 microcontroller. To operate in MII mode, the MCO signal must be configured to output 25 MHz, for RMII, 50 MHz.

By default the MII address of the Ethernet PHY is 0x01 and the initial configuration of the Ethernet PHY is selected as shown in [Table 2](#).

Table 2. Default configuration of the Ethernet PHY

Function	Default configuration
Auto negotiation	Enabled
10/100 Mb	100 Mb selected for auto negotiation advertisement
Half/full duplex	Full duplex selected for auto negotiation advertisement
Internal loopback	Disabled
Power-down	Disabled (PHY is not in power-down)
MII/RMII mode	MII selected

There are two LEDs embedded in RJ45 connector (CN5) which are used to indicate the status of the line:

- The green LED in the connector is switched on continuously when the Ethernet link is established with the counterpart.
- The yellow LED in the connector blinks when a transmission or a reception is ongoing.





The “Serial Management Interface” (SMI) is part of the MII interface and is used to transfer management information between MAC and PHY (access of the PHY registers).

The PHY can communicate with the STM32 microcontroller over MII or RMII. SB1, SB2 and SB3 must be configured according to the mode chosen. MII is chosen as a default option.

Table 3. Ethernet PHY configuration defined by SB1, SB2 and SB3

Function	MII	RMII
SB1	Removed	Fit 0 Ω resistor
SB2	Removed	Fit 0 Ω resistor
SB3	Fit 0 Ω resistor	Removed

Table 4. Logical levels on CFG0, CFG1

Jumper	Description	Configuration
CFG0 (3-pin resistor) (2.2 kΩ)	CFG0 = 0, default The resistor must be placed as shown:	
	CFG0 = 1 The resistor must be placed as shown:	
CFG1 (3-pin resistor) (2.2 kΩ)	CFG1 = 0, default The resistor must be placed as shown:	
	CFG1 = 1 The resistor must be placed as shown:	

This strapping option pair determines the operating mode of the MAC data interface. Default operation (no pull-ups) will enable normal MII mode of operation. Strapping CFG0 high will cause the device to be in RMII mode of operation, determined by the status of the CFG1 strap. Since the pins include internal pull-downs, the default values are 0.

Table 5. Ethernet PHY configuration defined by CFG0, CFG1

Function	CFG0	CFG1
MII	0	X
RMII	1	0

Note: **Important:** To choose between MII and RMII the pin RXDV of the PHY must be pulled high for RMII and pulled low for MII during reset or power-up of the PHY.

5.2 Power supply

The STEVAL-PCC012V1 demonstration board is designed to be powered by a 24 V DC power supply from CN2, P2. The board is protected against overvoltage by D4 Transil™ diode (SM6T33A) and against possible reverse polarity voltage from a wrong power plug-in by D1 Schottky diode (STPS3L40U). The input voltage is connected to the DC/DC converter U2 (L7986A).

Table 6. U2 DC/DC converter jumpers

Jumper	Description	Configuration
R4	To run DC/DC U2 on higher frequency R4 must be assembled with 102 kΩ resistor. Other components of the DC/DC must be changed accordingly. (Default - not assembled)	

5.3 General purpose 5-way joystick SW1

A 5-way general purpose joystick is available on the top side of the board.

Table 7. Joystick direction mapping

STM32 pin mapping	Joystick function
PE14	Central button
PE13	Direction right
PE12	Direction left
PE11	Direction down
PE10	Direction up

5.4 LEDs

4 general purpose LEDs (LD1-LD4) are available on the top side of the board. All LEDs are switched on when the related GPIO pin is driven low.

Table 8. LED mapping

STM32 pin mapping	LED
PD15	LD1
PD14	LD2
PE8	LD3
PE9	LD4

5.5 SPI bus communication

SPI signals are connected to the MEMS connector, Wi-Fi module and PLM. Use carefully the signal enable of the listed devices to select only one at a time. SPI signals can be also configured as analog inputs of the STM32 microcontroller ADC for optionally attached analog MEMS module. Please refer to [Section 5.7](#) for details.

5.6 I²C, USART signals branching for MEMS, Wi-Fi, digital audio and PLM

Table 9. MEMS, Wi-Fi, PLM I²C and USART signals branching









Jumper	Description	Configuration
JP2 (3-pin resistor)	PB7 is connected to MEMS extension connector as I ² C SDA. The jumper must be set as shown:	
	PB7 is connected as USART1_RX to Wi-Fi 2 position 10 and PLM. The jumper must be set as shown:	
JP3 (3-pin resistor)	PB6 is connected to MEMS extension connector as I ² C SCL. The jumper must be set as shown:	
	PB6 is connected as USART1_TX to Wi-Fi 2 position 10 and PLM. The jumper must be set as shown:	

Table 10. Digital audio I²C branching

Jumper	Description	Configuration
JP6 (3-pin resistor)	I ² C SDA is connected to DAC_FTM2 signal of CN3 (audio). The jumper must be set as shown:	
	GPIO PE0 is connected to DAC_FTM2 signal of CN3 (audio). The jumper must be set as shown:	
JP7 (3-pin resistor)	I ² C SCL is connected to DAC_FTM1 signal of CN3 (audio). The jumper must be set as shown:	
	GPIO PE1PB6 is connected to DAC_FTM1 signal of CN3 (audio). The jumper must be set as shown:	



5.7 Analog signals branching for MEMS

Table 11. Analog signals branching of STM32 pins PA6 and PA7 to analog MEMS

Jumper	Description	Configuration
R63 (0 Ω resistor)	ADC_IN6 is connected to analog MEMS connector (out1 signal) (STM32 pin PA6 can be also configured as SPI MISO)	R63 assembled
	ADC_IN6 is disconnected to analog MEMS connector (out1 signal)	R63 not assembled
R64 (0 Ω resistor)	ADC_IN7 is connected to analog MEMS connector (memsref signal) (STM32 pin PA7 can be also configured as SPI MOSI)	R64 assembled
	ADC_IN7 is disconnected to analog MEMS connector (memsref signal)	R64 not assembled

5.8 Clock source setting

Table 12. Clock source setting

Jumper	Description	Configuration
JP1 (3-pin resistor)	Crystal resonator X1 of 14.7456 MHz is connected to the STM32 (Default)	
	Crystal resonator X2 of 25.0000 MHz is connected to the STM32	

The benefit of using crystal resonator of desired frequency is described in STEVAL-CCA021V1 user manual UM0722. The correct crystal resonator frequency must be chosen with regard to using PHY or not. If the PHY is used, only X2 can be used.

5.9 Reset button

A manual reset button (RESET) is available on the board top side. It resets the STM32 microcontroller, both optional Wi-Fi modules U9, U10 and the Ethernet PHY U8.

5.10 USB-OTG configuration

The STM32 microcontroller can distinguish between the host and device mode of the connected USB circuit by reading ID pin. It is possible to disconnect ID pin from USB connector CN4 (see [Table 13](#)).

Table 13. USB-OTG configuration

Jumper	Description	Configuration
R32	When 0 Ω resistor is assembled in this position, the ID signal of the STM32 microcontroller and the ID signal of the connector CN4 are interconnected. Otherwise there are disconnected. (Default - assembled)	

5.11 MicroSD Card

The microSD Card connector connected to the SPI1 interface of the STM32 microcontroller is available on the board. MicroSD Card detection is done through PA4 GPIO signal when the card is inserted.

Figure 6. SD Card formats

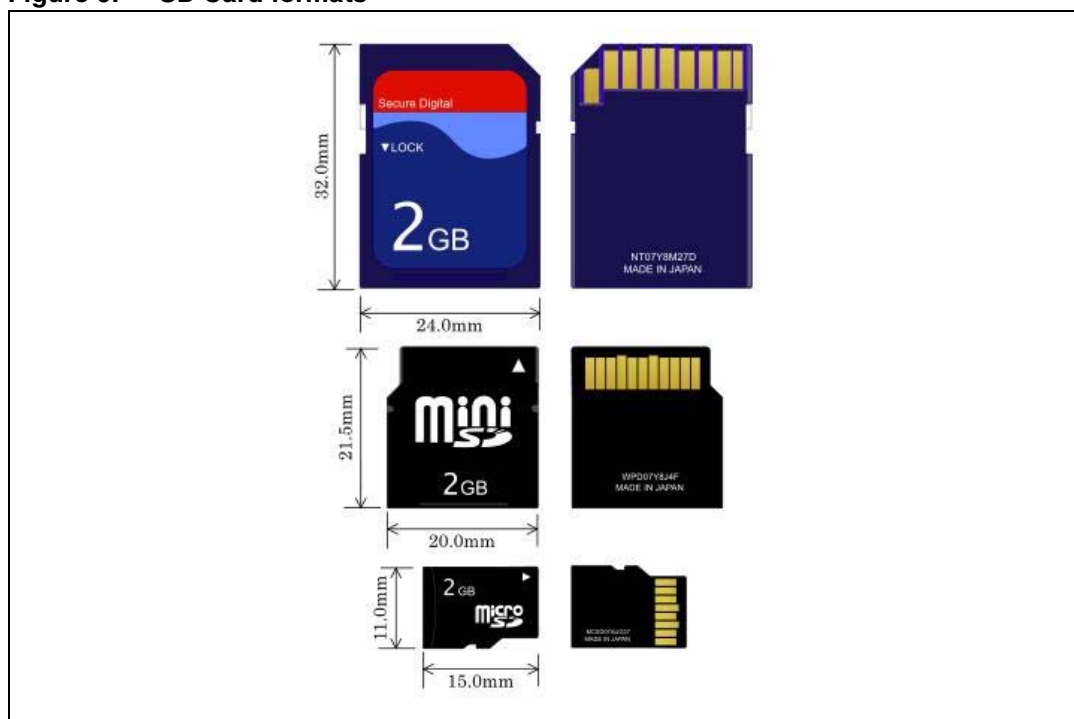

5.12 Wi-Fi optional modules





There are two positions for optional Wi-Fi modules:

Table 14. Optional Wi-Fi modules configuration

Position	Interface used	Note
U9 - module-1	SPI1 + CS_Wi-Fi	
U10 - module-2	USART1	These signals are shared with I ² C for MEMS extension connector, refer to Section 5.6 . JP2, JP3 must be configured accordingly.

5.12.1 Wi-Fi optional module-1 U9 settings

Table 15. Wi-Fi optional module-1 U9 settings

Jumper	Description	Configuration
JP4 (3-pin resistor)	JTGENPB7 is pulled to GND. The jumper with resistance of 10 kΩ must be set as shown:	
	JTGENPB7 is pulled to +3.3 V. The jumper with resistance of 10 kΩ must be set as shown:	
JP5 (3-pin resistor)	JTGRNPB6 is pulled to GND. The jumper with resistance of 10 kΩ must be set as shown:	
	JTGTN is pulled to +3.3 V. The jumper with resistance of 10 kΩ must be set as shown:	

5.12.2 Wi-Fi optional module-2 U10 settings and signal description

Table 16. Wi-Fi optional module-2 U10 settings and signal description

Signal on U10	SDIO description	SPI description	STM32 SPI signals
GPIO4 - SD_CMD	DI	MOSI	MOSI
GPIO5 - SD_D0	DO	MISO	MISO
GPIO6 - SD_D1	IRQ	—	—
GPIO7 - SD_D2	NC	—	—
GPIO8 - SD_3	\overline{CS}	\overline{SS}	SCS_N
GPIO9 - SD_CLK	SCK	SCK	SCK

6 Connectors

6.1 JTAG connector CN1

The CN1 connector allows to connect the STM32 microcontroller to a JTAG cable.

Figure 7. JTAG connector pinout

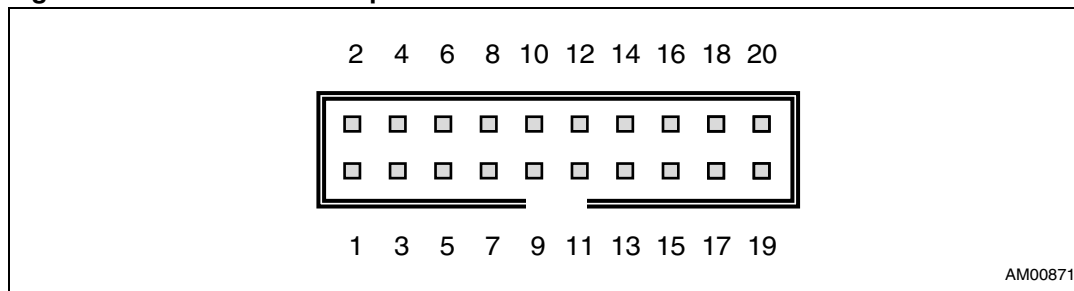

AM00871

Table 17. JTAG connector signals

Pin	Signal	Pin	Signal	Pin	Signal	Pin	Signal
1	+3.3 V	6	GND	11	JRTCK	16	GND
2	+3.3 V	7	JTMS	12	GND	17	DBGRRQ
3	JTRST	8	GND	13	JTDO	18	GND
4	GND	9	JTCK	14	GND	19	DBGACK
5	JTDI	10	GND	15	JRST	20	GND

6.2 Audio extension connector CN3

The CN3 connector allows to connect an STEVAL-CAA021V1 audio demonstration board.

Figure 8. I²S audio connector of the TS4657 audio card - schematic

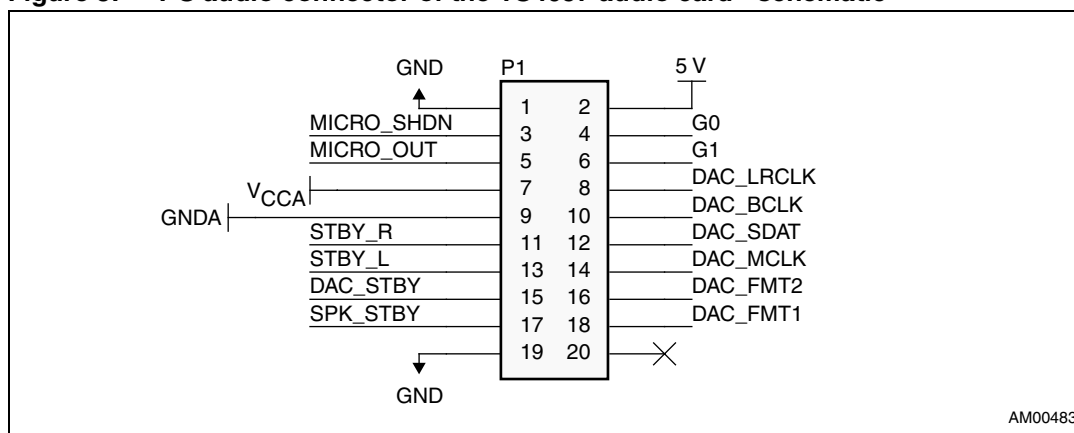

AM00483

Table 18. Description of the I²S audio connector pins of the TS4657 audio card

Pin	Signal	Pin	Signal	Pin	Signal	Pin	Signal
1	GND	6	G1 gain select for TS2012 (PD3)	11	Right channel mute for TS2012 (PD4)	16	Data format selection FMT2 for TS4657 (PE2)
2	+ 5 V	7	V _{CCA} +3.3 V supply voltage for microphone domain	12	TS4657 SDAT I ² S signal (PC12) (SPI3MOSI)	17	Standby for TS4962 (on-board speaker and mono jack) (PD7)
3	Microphone shutdown (PB2)	8	TS4657 LRCLK I ² S signal (PA15) (JTD) (I ² S3_WS)	13	Left channel mute for TS2012 (PD5)	18	Data format selection FMT1 for TS4657 (PE1)
4	G0 gain select for TS2012 (PD2)	9	GND A ground for microphone domain	14	TS4657 MCLK I ² S signal (master clock) (PC7) (I ² S3_MCK)	19	GND
5	Analog output from microphone preamplifier (PB1) (ADC12_IN9)	10	TS4657 BCLK I ² S signal (PC10) (SPI3_SCK)	15	Standby for TS4657	20	NC

Additional information can be found in the STEVAL-CAA021V1 user manual (UM0722).

6.3 Analog/digital MEMS extension connector CN6 and CN8

The CN6 and CN8 connectors allows to connect STEVAL-MKI0xxV1 MEMS demonstration boards (gyroscope, accelerometer) that are compatible with 24 DIL socket. The MEMS extension must be fitted in both connectors CN6 and CD8 in the same time. The MEMS extension when plugged uses only the right half of the CN8 connector terminals. The left half is free even if the MEMS extension is plugged.

Figure 9. Digital MEMS connector pinout

Table 19. Digital MEMS connector signals

Pin	Signal (MEMS)	Signal description
1	N. C.	
2	HP	High-pass filter reset, signal for gyroscope
3	SPI ₁ - MISO	
4	SPI ₁ - MOSI	Shared with I ² C ₁ - SDA
5	SPI ₁ - CLK	Shared with I ² C ₁ - SCL
6	CS_MEMS	Chip select for the SPI ₁ device
7	PD	Power-down of the device
8	FS	Full scale of the measured range
9	SelfTest	
10	Int2	Interrupt request
11	Int1	Interrupt request
12	GND	

Figure 10. GPIO and analog connector pinout

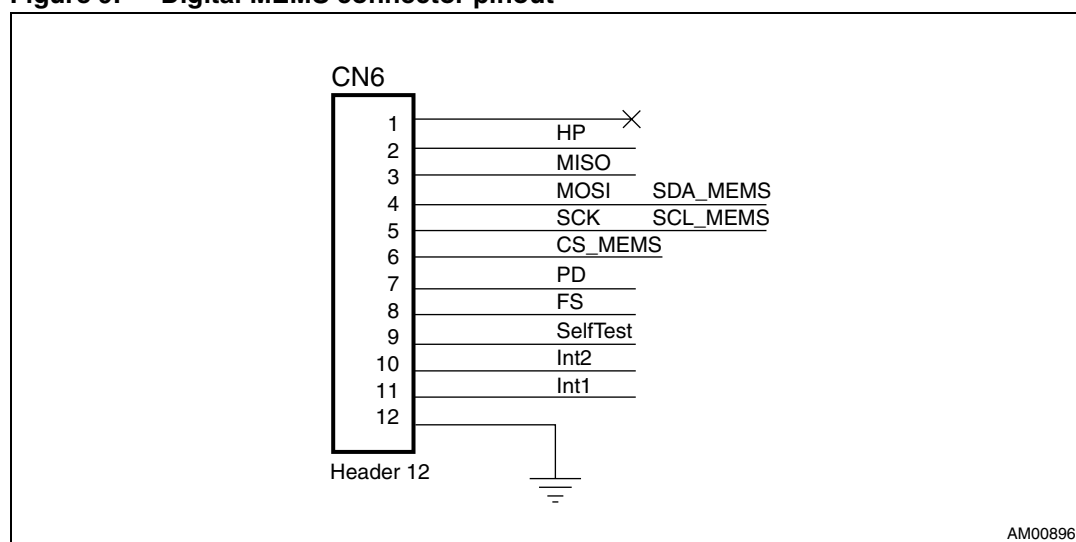
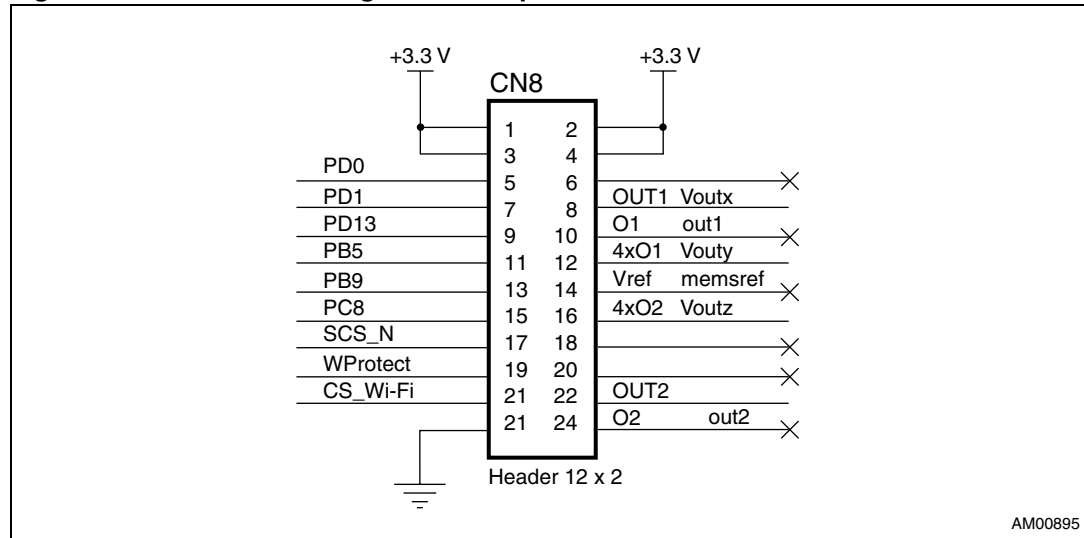

Table 20. GPIO and analog MEMS connector signals

Pin	Signal - the left half (GPIO)	Pin	Signal - the right half (MEMS)
1	+3.3 V	2	+3.3 V
3	+3.3 V	4	+3.3 V
5	GPIO (PD0)	6	NC
7	GPIO (PD1)	8	X - axis, or GYRO output-1 (PC0) (ADC12_IN10)
9	GPIO (PD13)	10	NC
11	GPIO (PB5)	12	Y - axis (PC4) (ADC12_IN14)
13	GPIO (PB9)	14	NC
15	GPIO (PC8)	16	Z - axis (PC5) (ADC12_IN15)
17	Serial chip select from host (PC9)	18	NC
19	U9 Wi-Fi module-1 write protect (PC15)	20	NC
21	U9 Wi-Fi module-1 chip enable (PE15)	22	GYRO output-2 (PB0) (ADC12_IN8)
23	GND	24	NC

Additional information can be found in the STEVAL-MK10xxV1 user manual.

6.4 Power line networking extension connector CN7

The connector CN7 is dedicated for the interconnection with ST7590 OFDM PRIME compliant power line modem demonstration board through UART and SPI.

Figure 11. Connector CN7 for PLM, USART and SPI interface

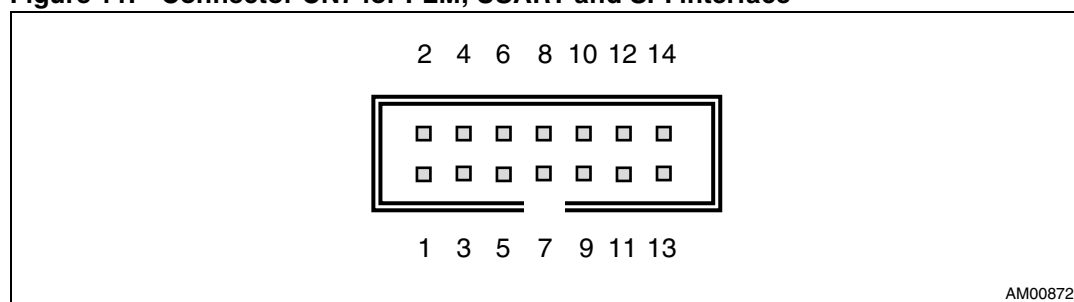

Table 21. Connector CN7 for PLM, USART and SPI interface

Pin	Signal	Pin	Signal
1	USART_TXD_LV+3V3	2	USART_RDX_LX
3	GND	4	VCC_LV
5	MISO_LV	6	SCLK0_LV
7	MOSI_LV	8	SSN0_LV

Table 21. Connector CN7 for PLM, USART and SPI interface

Pin	Signal	Pin	Signal
9	RTS_LV	10	CTS_LV
11	MDM_RESn_LV	12	DFU_FORCE_LC
13	GND	14	GND

Signals xxxx_LV mean, that these signals operate up to VCC_LV voltage level. VCC_LV is connected to 3.3 V.

6.5 Power test points

These three testing points allow to measure the power supply voltage.

Table 22. Test points

Test point name	Signal description
+3.3 V	+3.3 V output from U3 linear voltage regulator for STM32, PHY, Wi-Fi, MEMS and audio extension.
+5.0 V	+5.0 V output from U2 switching power supply for USB-OTG, audio extension and U3.
GND	Ground

6.6 USB connector CN4

There is USB mini connector on the board. The terminal pin description is shown in [Table 23](#).

Table 23. USB connector CN4 signals

Pin	Signal description
1	USB_VBUS
2	ID OTG identification of the device connected
3	USB-DP data plus signal
4	USB-DM data minus signal
5	GND

6.7 U10 Wi-Fi module-2 debugging signals TXupd and RXupd

These two testing points allow to update the firmware of the optional Wi-Fi module-2.

Table 24. U10 Wi-Fi module-2 debugging signals TXupd and RXupd

Signal	Signal description
TXupd	UART TX update signal
RXupd	UART RX update signal

6.8 Ethernet RJ45 connectors CN5

Figure 12. Ethernet RJ45 connectors CN5 - front view

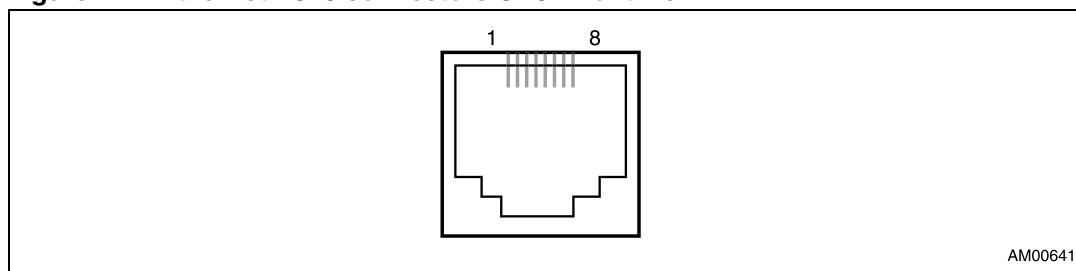

AM00641

Table 25. RJ45 connectors CN5

Pin	Description	Pin	Description
1	TxData+	2	TxData-
3	RxData+	4	NC
5	NC	6	RxData-
7	NC	8	NC

6.9 MicroSD Card connector CN9

Figure 13. MicroSD Card connector CN9

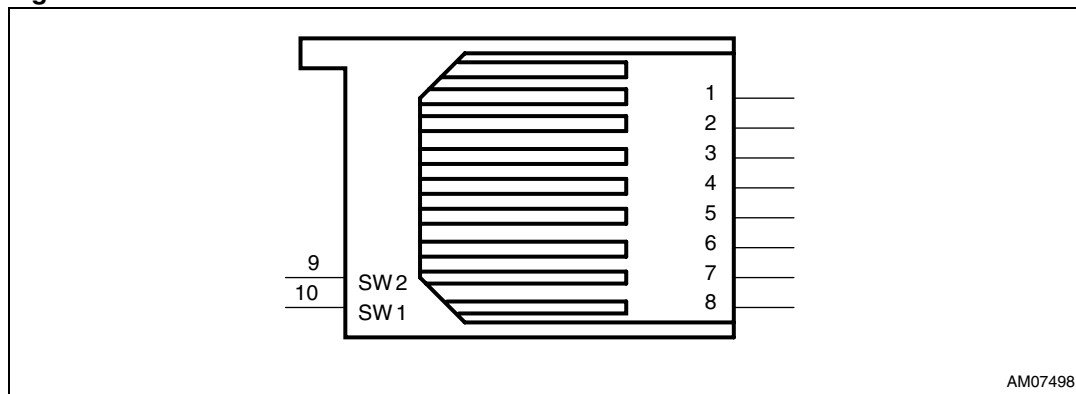

AM07498

Table 26. MicroSD Card connector CN9

Pin	Description	Pin number	Description
1	NC	6	GND
2	CS_SDcard (PE7)	7	MISO (SPI ₁ - PA6)
3	MOSI (SPI ₁ - PA7)	8	NC
4	+3.3 V	9	GND
5	SCK (SPI ₁ - PA5)	10	SD_detect (PA4)

6.10 Schematics

Figure 14. Power supply

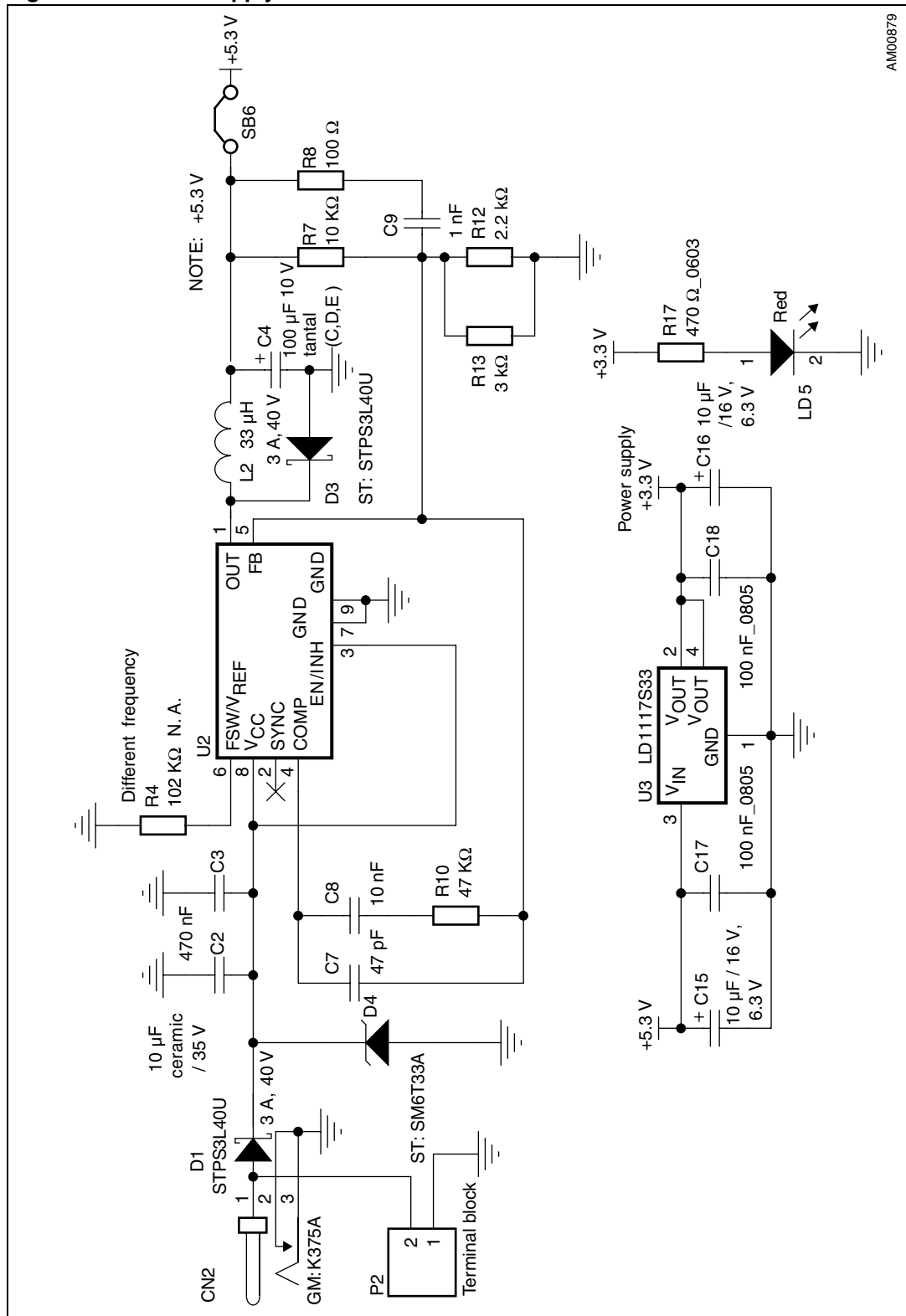

AM00879



Figure 15. STM32 - part 1(inputs, outputs, clock, reset)

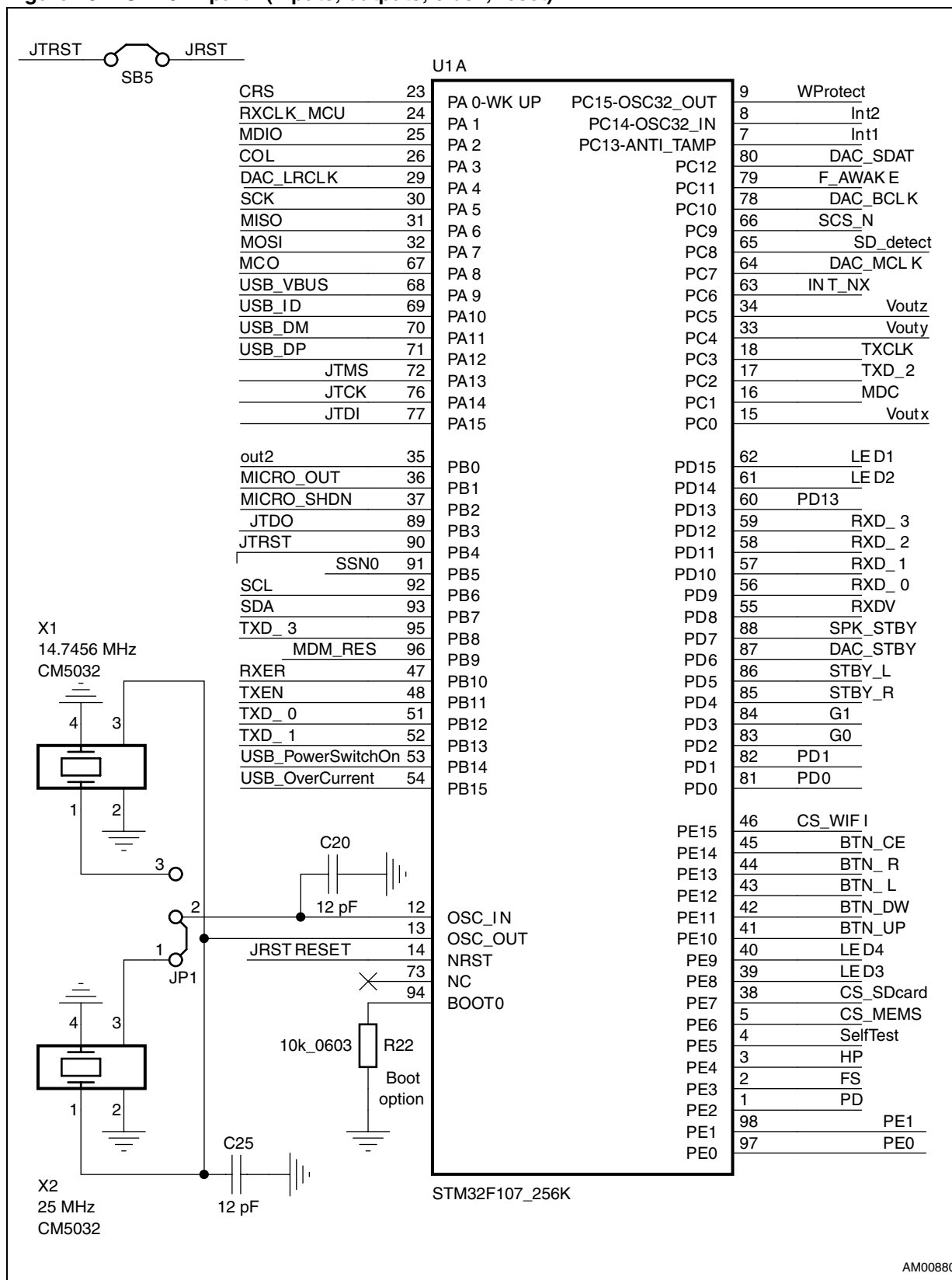
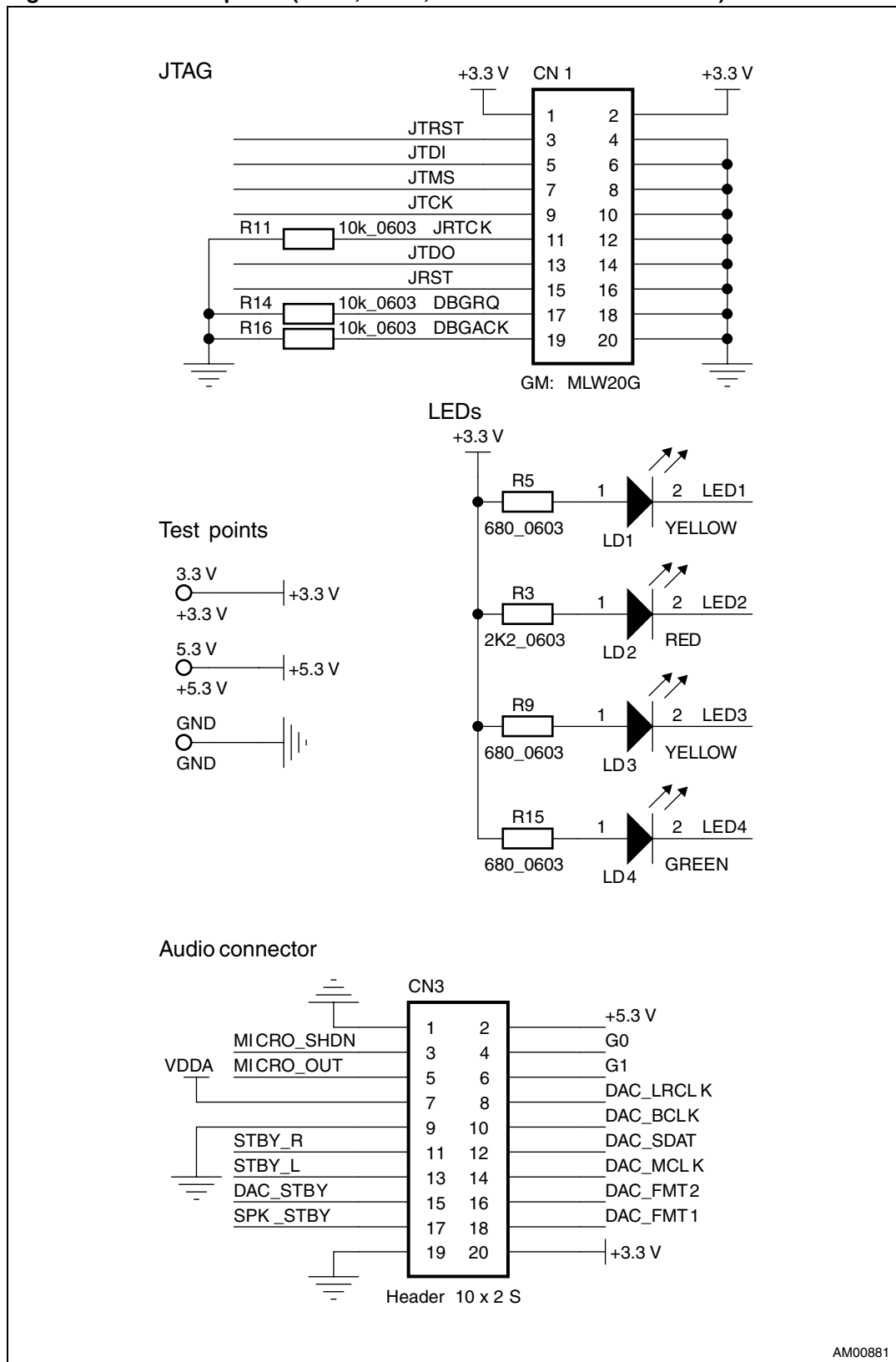
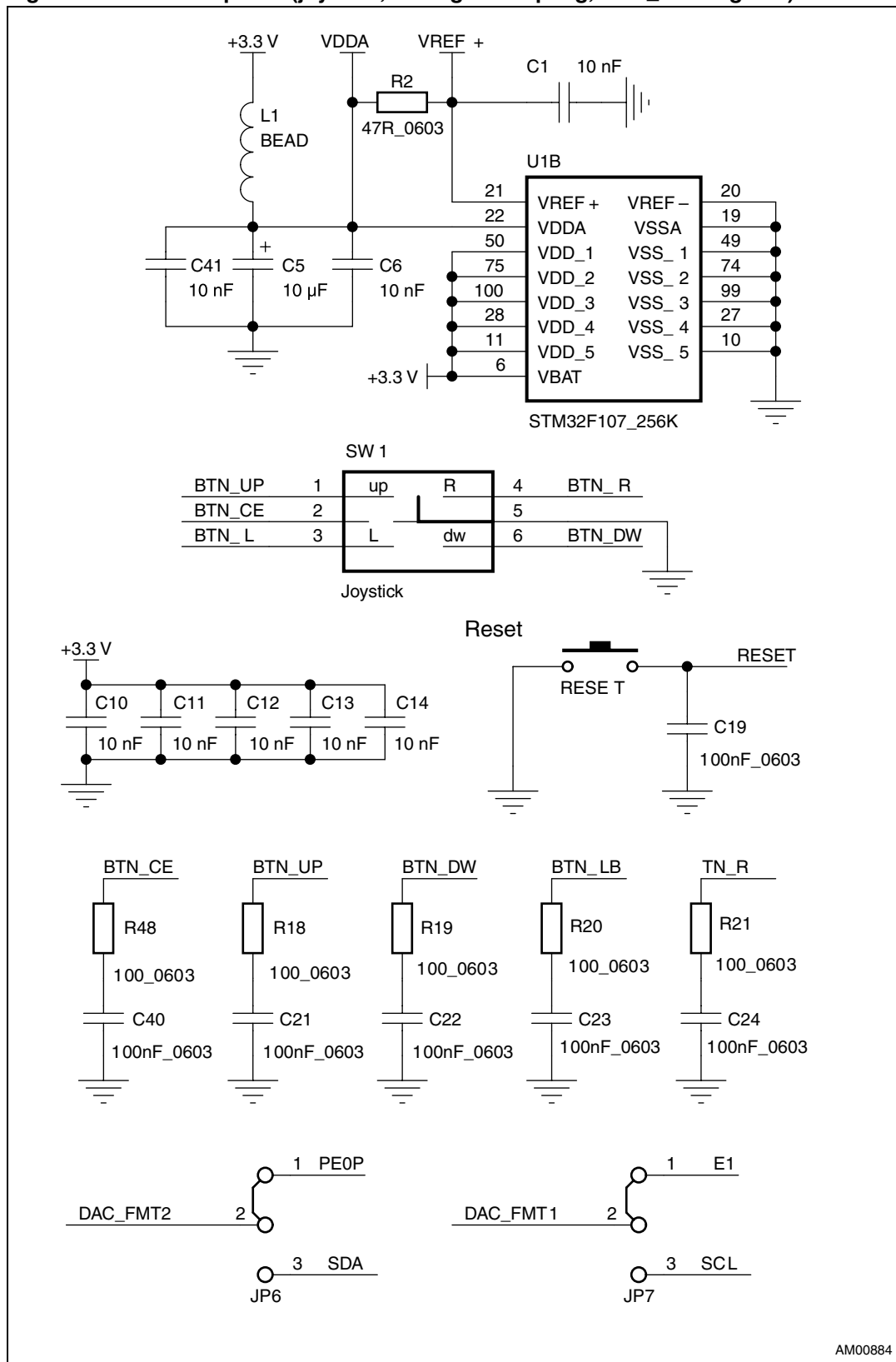

Figure 16. STM32 - part 2 (JTAG, LEDs, audio extension connector)



AM00881

Figure 17. STM32 - part 3 (joystick, analog decoupling, DAC_FMT signals)



AM00884

Figure 18. Ethernet - part 1 (PHY pinout)

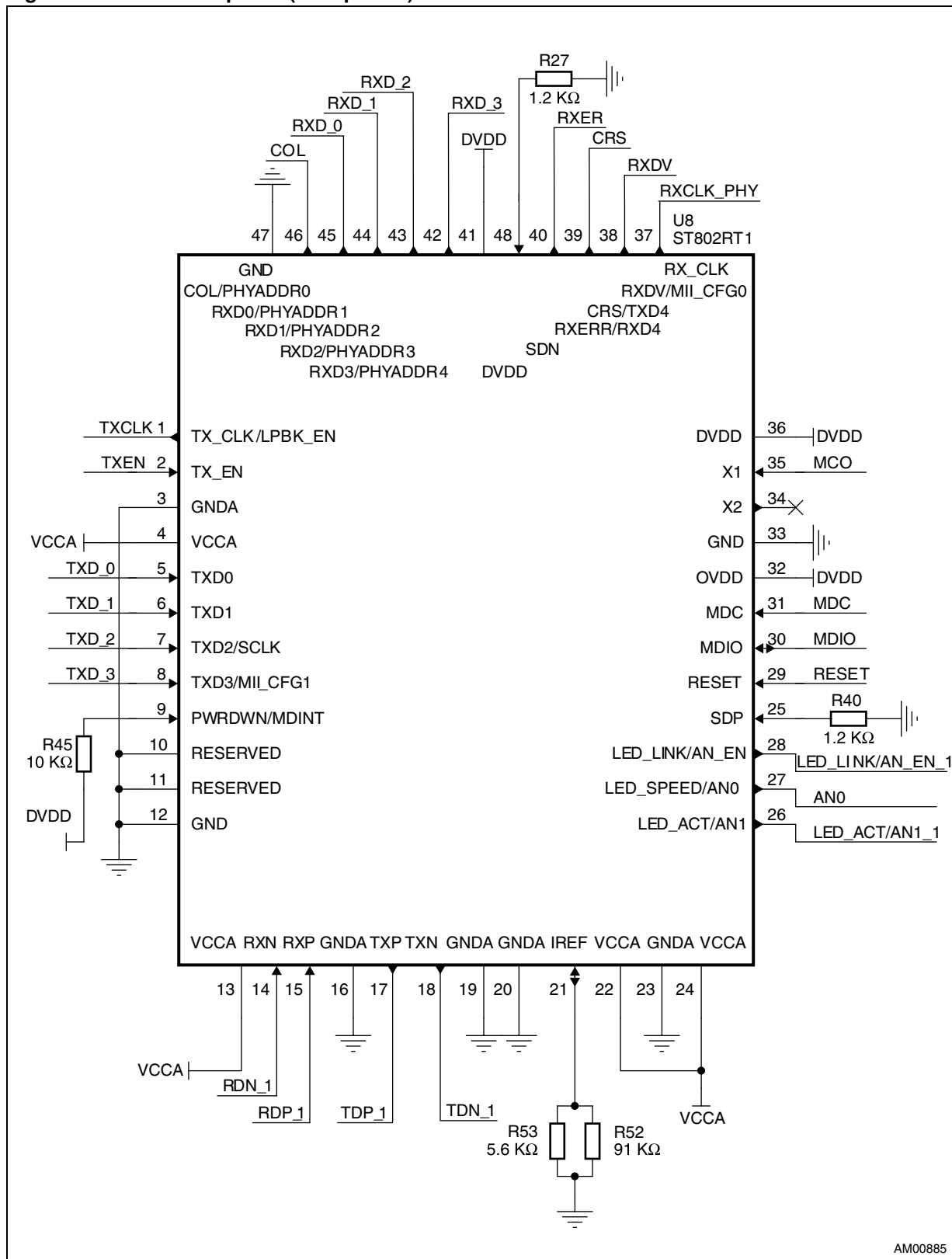

AM00885

Figure 19. Ethernet - part 2 (overvoltage protection, PHY configuration)

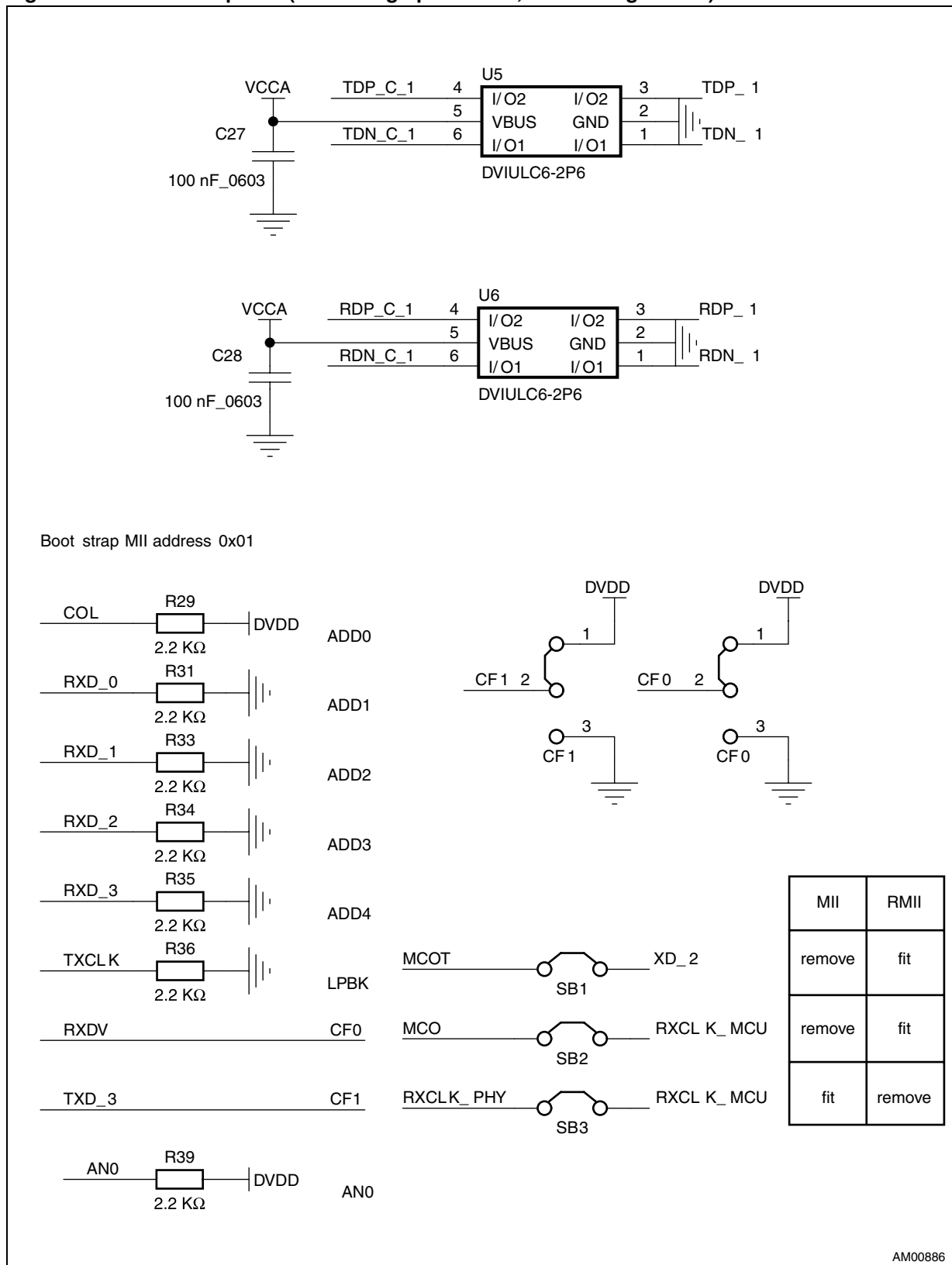

AM00886

Figure 20. Ethernet - part 3 (magnetics)

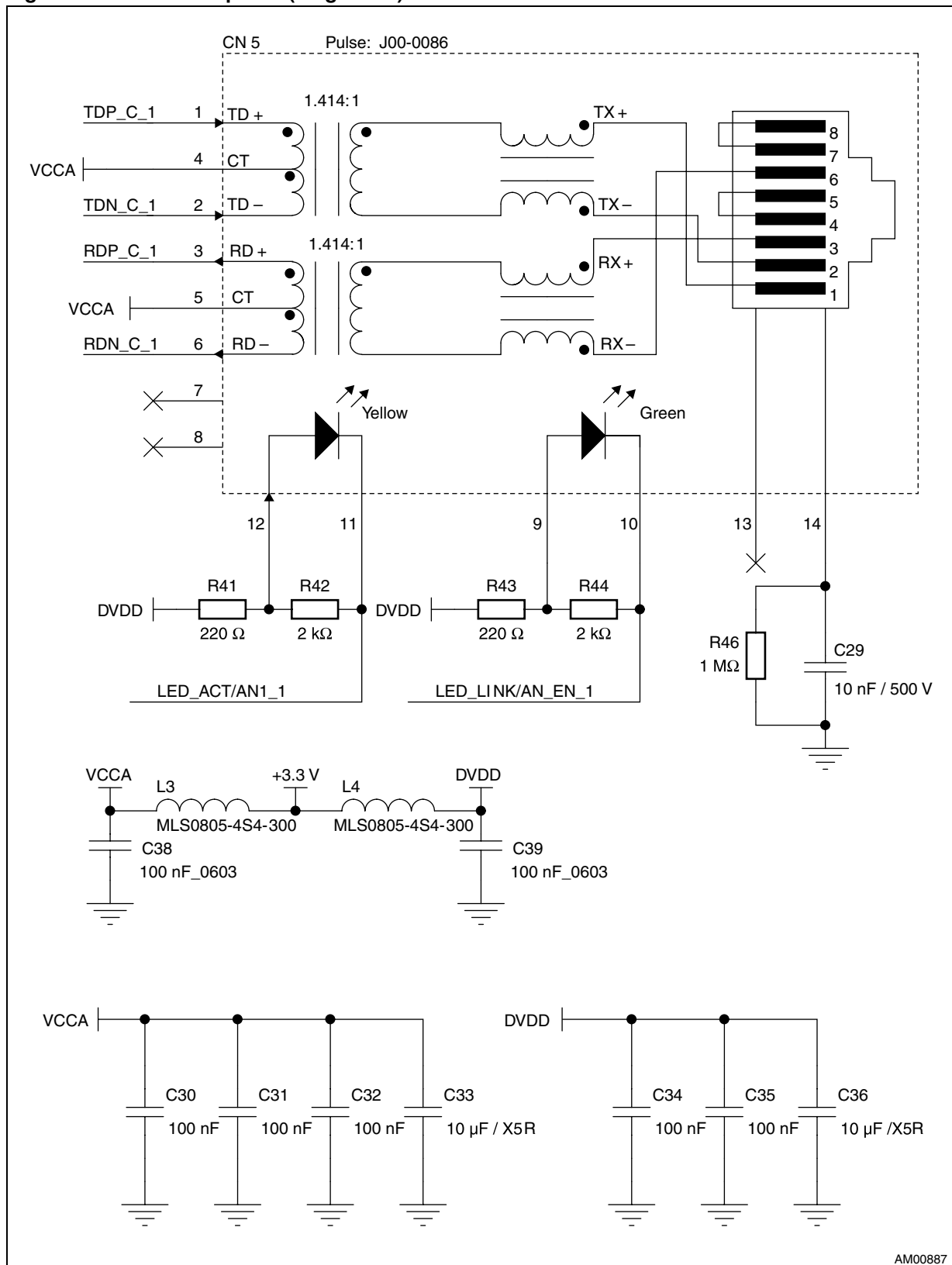

AM00887

Figure 21. USB-OTG

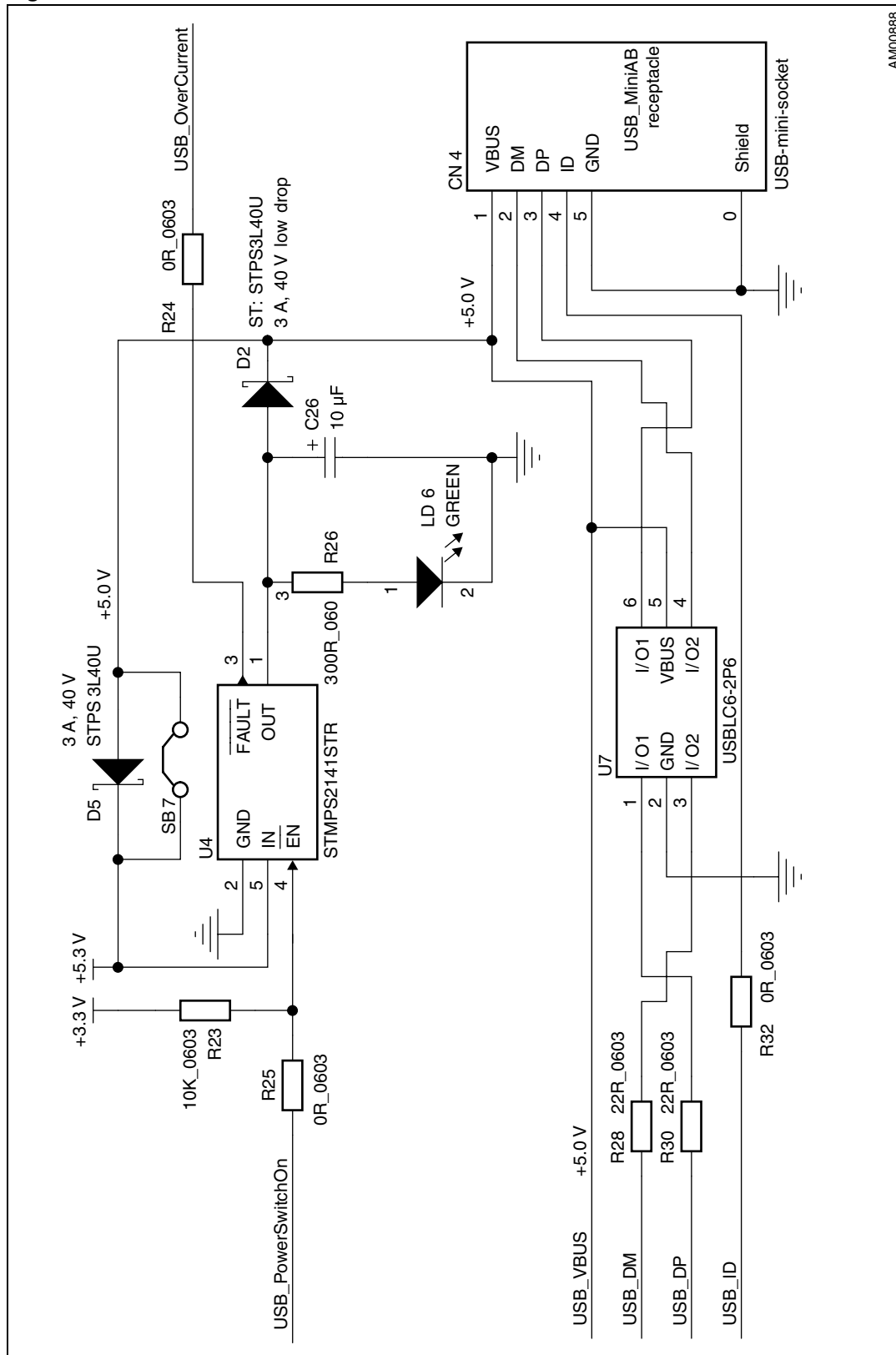

AM00888

Figure 22. Wi-Fi module-1

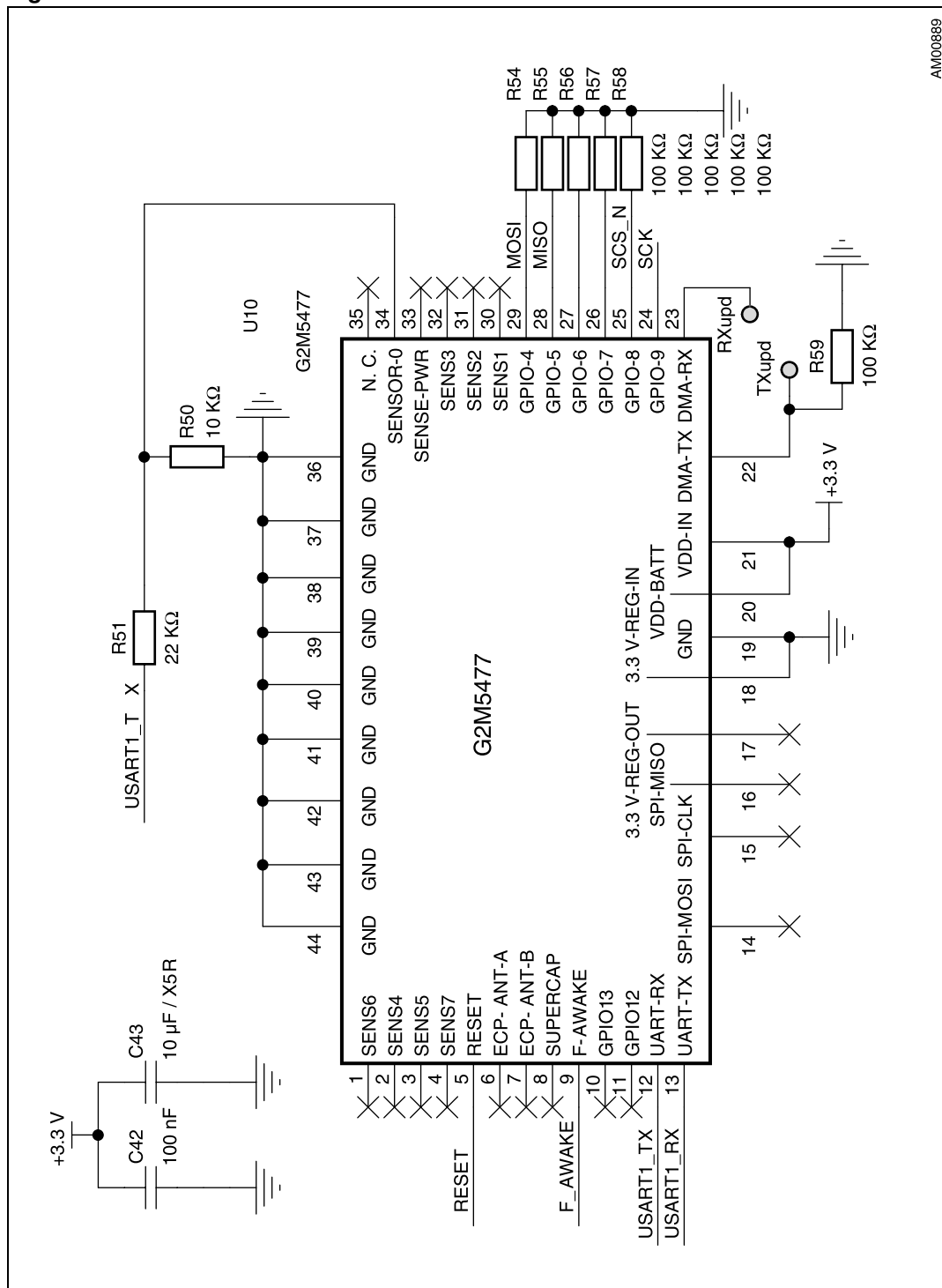

AM00889

Figure 23. Wi-Fi module-2

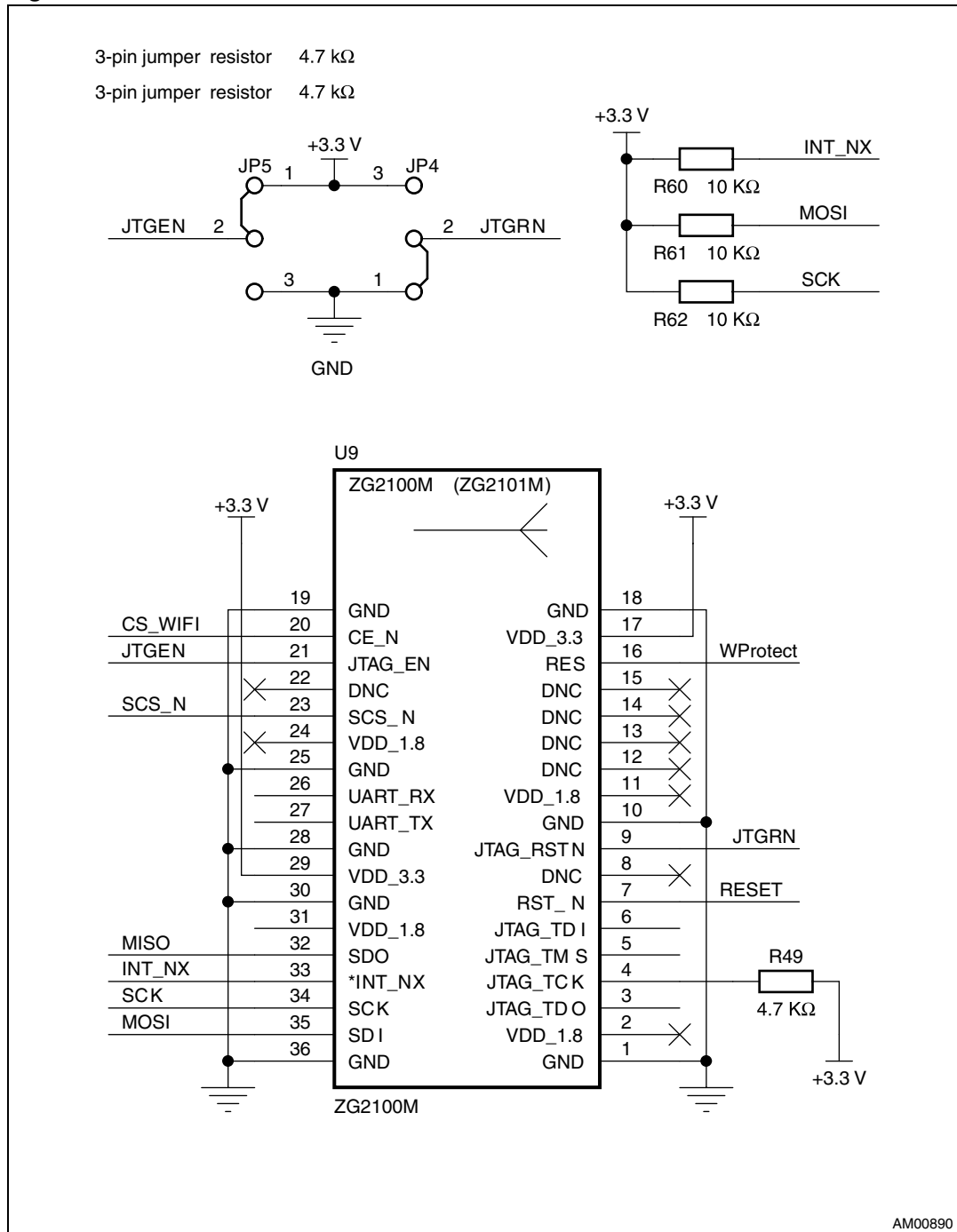

AM00890

Figure 24. MicroSD Card

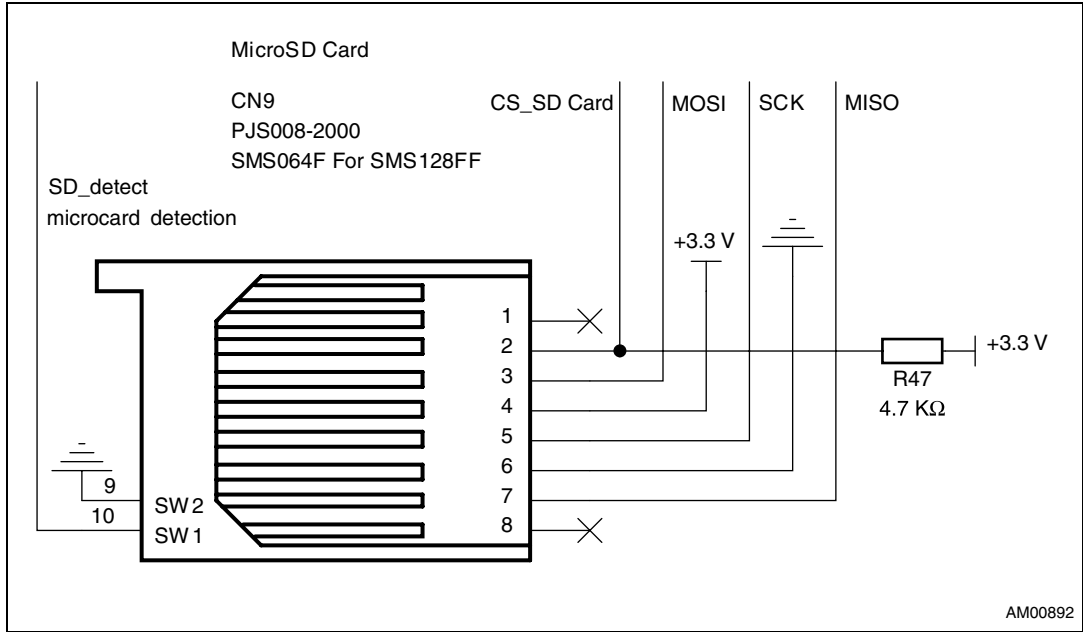
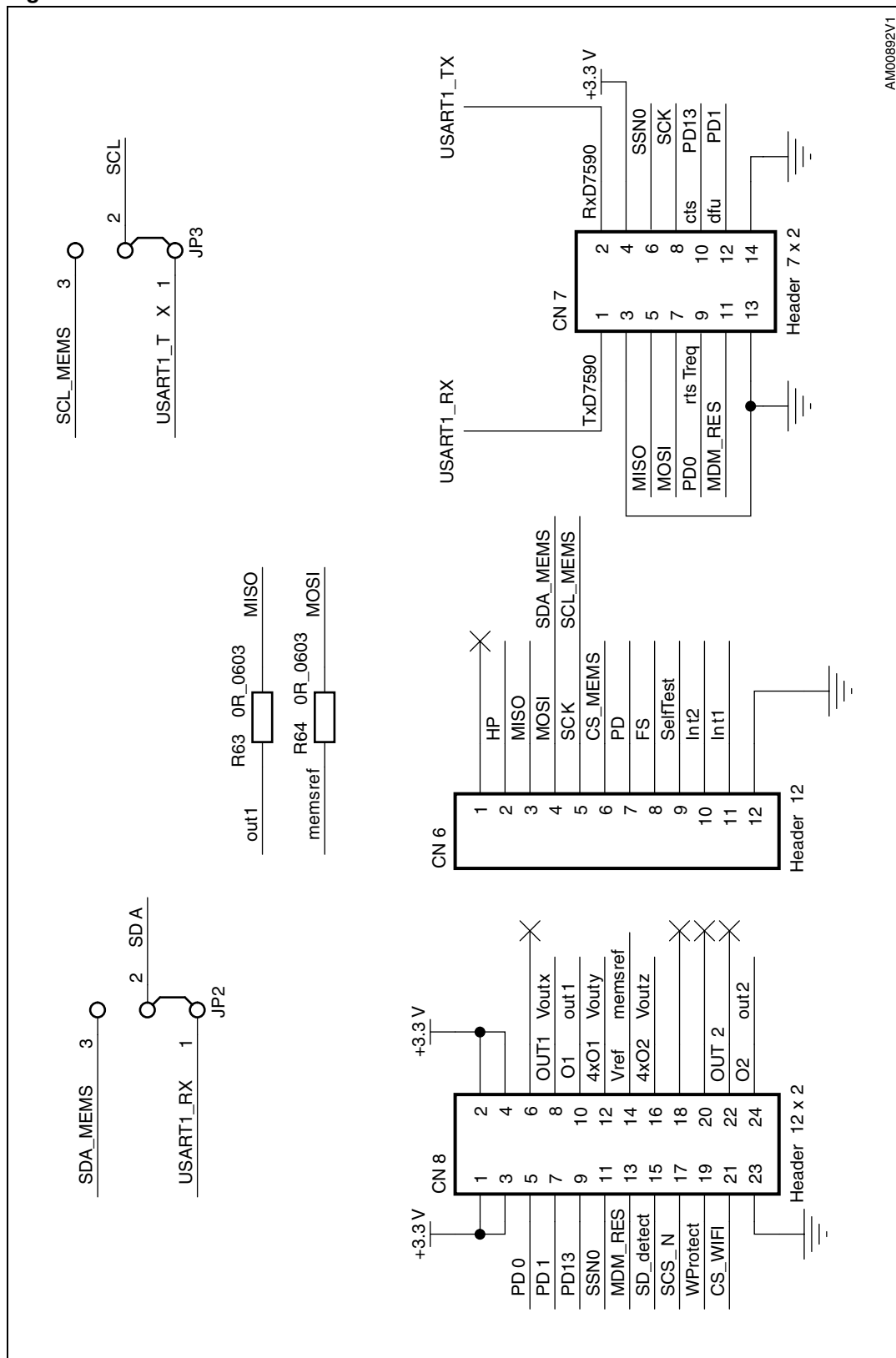

Figure 25. MEMS extension connectors



AM00892V1

6.11 Power supply connectors CN2, P2

Figure 26. Power supply connector CN2

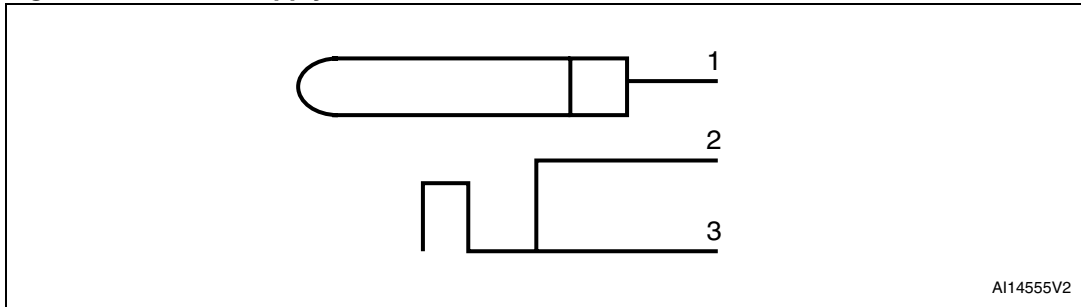

AI14555V2

Table 27. Power supply connector CN2

Pin	Signal	Pin	Signal
1	24 V DC	3	GND
2	GND		

Figure 27. Power supply connector P2

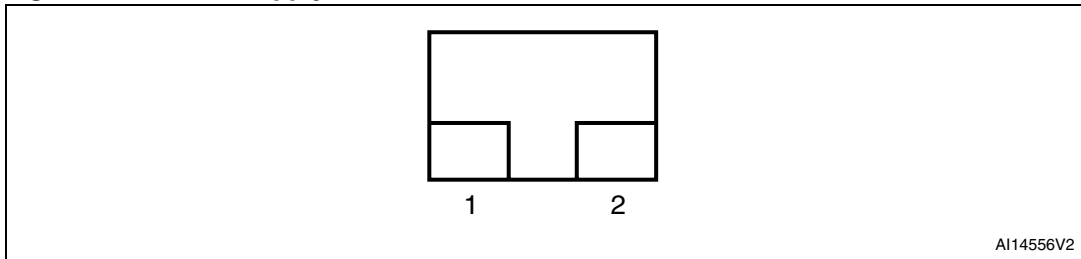

AI14556V2

Table 28. Power supply connector P2

Pin	Signal
1	24 V DC
2	GND

7 Evaluation software

The STM32F107xx connectivity gateway is delivered with software evaluation package including the demonstration applications and libraries in C source code. The package includes:

- Connectivity Gateway demonstration application - USB audio card, TCP/IP demonstration based on lwIP stack: DHCP client, Telnet server, Webserver, TFTP server utilizing microSD Card, server/clients application
- Example applications:
 - Audio streaming application - USB audio card - see UM0722
 - Webserver based on uIP TCP/IP stack - see UM0819
 - MEMS USB bridge application showing MEMS data on PC - see UM0701.

7.1 Connectivity Gateway demonstration application (CG demonstration)

The “CG demonstration” demonstrates the audio and Ethernet capabilities of the board. It also demonstrates the MEMS sensor data acquisition feature.

To run the CG demonstration properly, the STEVAL-PCC012V1 and STEVAL-CCA021V1 must be interconnected. To perform MEMS sensor data acquisition, one of the compatible STEVAL-MKI0xxV1 boards should be connected.

The CG demonstration consists of two parts: the audio and the Ethernet demonstration. After reset the IP address is resolved using DHCP client, and LEDs are toggled until this process is completed.

The audio part demonstration reproduces the board IP address. It is then reprogrammed to play sounds coming through the USB interface, making the board behave as an USB audio card.

The Ethernet demonstrations are based on lwIP TCP/IP stack and consist of:

- DHCP client, for IP address setting
- Hello example based on the Telnet protocol
- TFTP server, which transfers files from and to the microSD Card inserted in CN9 connector.
- Web server showing pages with pictures and also data acquired from MEMS sensor
- Server/clients example, which uses multiple boards and allows clients to control the server's LEDs.

The Ethernet demonstrations are described in details in application note AN3102. The description is also valid for the CG demonstration except for small modifications related to server/clients example. Here the server is selected at startup by keeping the joystick button pressed. The selected function of the board is shown by LEDs after the IP address is resolved as shown by [Table 29](#). The position of joystick on the client board controls LEDs on the server board.

Table 29. Board function indication after reset for server/clients example

Function	LED1	LED2	LED3	LED4
Static IP	Off	Off	Off	On
Client	Off	Off	On	On
Server	Off	On	On	On

Figure 28. Connectivity Gateway Webserver demonstration

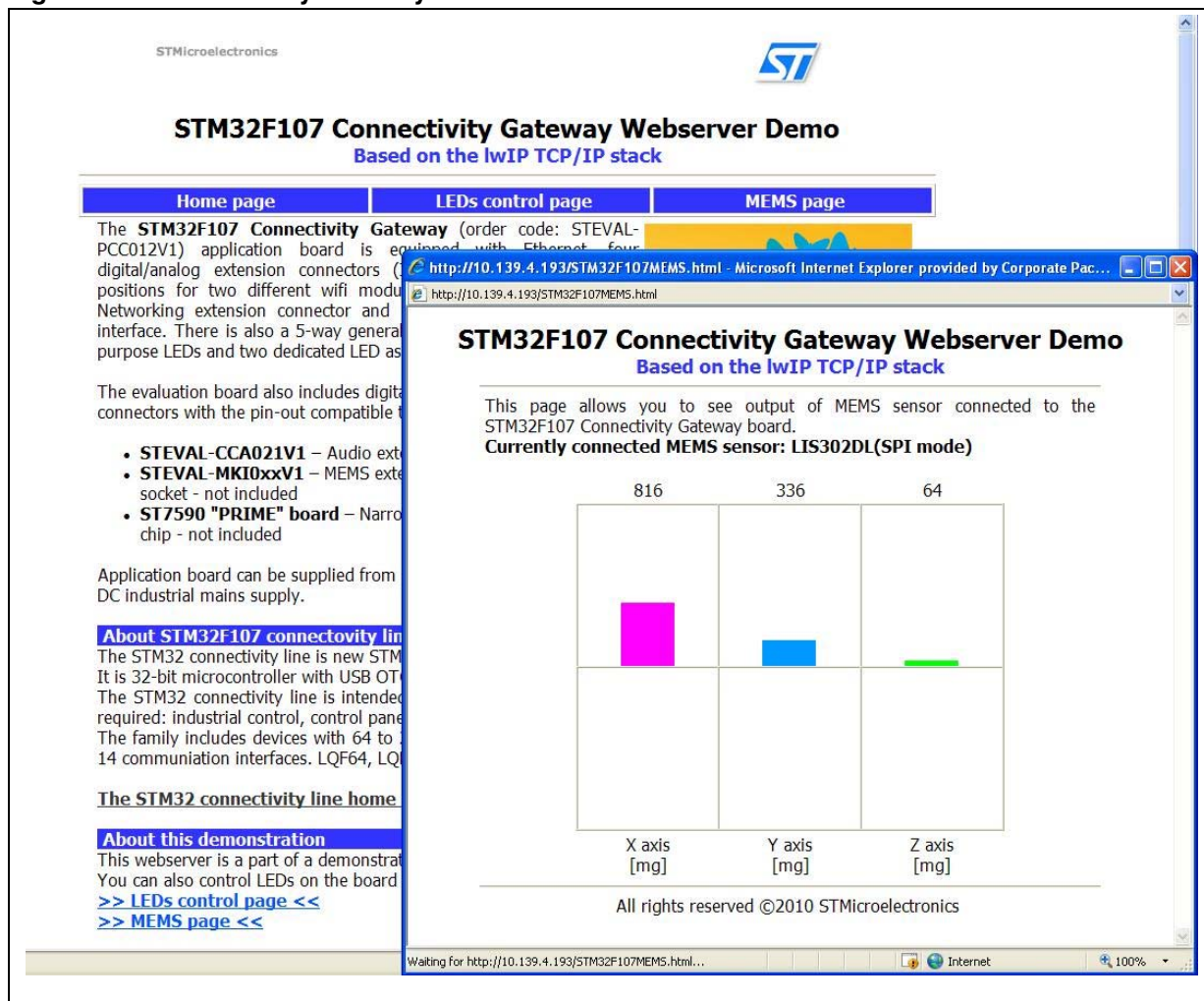

8 BOM of the board

Table 30. Bill of material

Designator	Value	Comment
LD1, LD3	SMD 0805 LED	Yellow
LD2, LD5	SMD 0805 LED	Red
LD4, LD6	SMD 0805 LED	Green
D4	Protection diode	SM6T33A
RESET	Button	SW-PB
SB4	Soldering bridge	Soldbridge
D1, D2, D3, D5	STPS3L40U	STMicroelectronics: STPS3L40U
CN5	Ethernet transformer con.	J00-0086
R11, R14, R16, R18, R19, R20, R21, R22, R23, R48	10 kΩ	10k_0603
R17	470 Ω	470R_0603
R2	47 Ω	47R_0603
R24, R25, R32	0 Ω	0R_0603
R26	300 Ω	300R_0603
R28, R30	22 Ω	22R_0603
R3	2.2 kΩ	2k2_0603
R5, R9, R15	680 Ω	680_0603
C15, C16	10 μF / 16 V	10 μF / 16 V
C26	47 μF	10 μF
C4	47 μF	100 μF
C5	10 μF	10 μF
U3	3.3 V voltage regulator	LD1117S33
CN2	Power connector	K375A
L1	Inductor 100 μH	Bead
L2	Inductor 33 μH	MSS1260-333
CN8	Male connector dual in line	Header 12 X 2
CN6	Male connector single in line	Header 12
CN3	Female connector dual in line	Header 10 X 2 S
P2	Terminal block	Terminal block
CN1	Male connector with key	JTAG
R10	47 kΩ	47 kΩ
R12, R13	5.6 kΩ 91 kΩ	1.28 kΩ

Table 30. Bill of material (continued)

Designator	Value	Comment
R27, R29, R31, R33, R34, R35, R36, R37, R38, R39, R40, R41, R42, R43, R44, R45, R46, R47, R49, R50, R51, R52, R53, R54, R55, R56, R57, R58, R59	1.2 k Ω , 1 M Ω , 2 k Ω , 2.2 k Ω , 4.7 k Ω , 5.6 k Ω , 10 k Ω , 22 k Ω , 91 k Ω , 100 k Ω , 220 Ω	
R4	N. A. (102 k Ω)	N. A. (102 k Ω)
R7	10 k Ω	10 k Ω
R8	100 Ω	100 Ω
C30, C31, C32, C34, C35, C42	100 nF	
C33, C36, C43	10 μ F / X5R	
U10	Wi-Fi module	G2M5477
U5, U6	Ethernet voltage protection	DVIULC6-2P6
X1	Crystal resonator	14.7456MHz
X2	Crystal resonator	25 MHz
C1, C6, C8, C10, C11, C12, C13, C14, C41	Capacitor	10 nF
C17, C18	100 nF	Footprint 100n_0805
C19, C21, C22, C23, C24, C40	100 nF	Footprint 100 nF_0603
C2	10 μ F / ceramic / 35 V	10 μ F ceramic / 35 V
C20, C25		12 pF
C27, C28		100 nF
C29		10 nF / 500 V
C3	470 nF	470 nF
C38, C39		100 nF
C7	47 pF	47 pF
C9	1 nF	1 nF
U8		ST802RT1
JP4, JP5		3-pin jumper resistor 4.7 k Ω
JP1, JP2, JP3		3-pin jumper resistor
3V3		+3.3 V
5V0		+5.0 V
CN4		565790576
CN9		PJS008-2000
DDD1		ST_LOGO
DDD2, DDD4		ROH1
DDD3		ROH2
GND		GND
hole1, hole2, hole3, hole4		Distance hole

Table 30. Bill of material (continued)

Designator	Value	Comment
L3, L4		MLS0805-4S4-300
RXupd, TXupd		Update
SW1		Joystick
U1		STM32F107VCT6_256K
U2	L5973D	ST: L5973D
U4		STMPS2141STR
U7		USBLC6-2P6
U9		ZG2100M

9 Revision history

Table 31. Document revision history

Date	Revision	Changes
12-Mar-2010	1	Initial release.
20-Apr-2011	2	Updated Figure 13 , Figure 25 and Table 30 , corrected typo in Table 27 and Table 28 .

Please Read Carefully:

Information in this document is provided solely in connection with ST products. STMicroelectronics NV and its subsidiaries ("ST") reserve the right to make changes, corrections, modifications or improvements, to this document, and the products and services described herein at any time, without notice.

All ST products are sold pursuant to ST's terms and conditions of sale.

Purchasers are solely responsible for the choice, selection and use of the ST products and services described herein, and ST assumes no liability whatsoever relating to the choice, selection or use of the ST products and services described herein.

No license, express or implied, by estoppel or otherwise, to any intellectual property rights is granted under this document. If any part of this document refers to any third party products or services it shall not be deemed a license grant by ST for the use of such third party products or services, or any intellectual property contained therein or considered as a warranty covering the use in any manner whatsoever of such third party products or services or any intellectual property contained therein.

UNLESS OTHERWISE SET FORTH IN ST'S TERMS AND CONDITIONS OF SALE ST DISCLAIMS ANY EXPRESS OR IMPLIED WARRANTY WITH RESPECT TO THE USE AND/OR SALE OF ST PRODUCTS INCLUDING WITHOUT LIMITATION IMPLIED WARRANTIES OF MERCHANTABILITY, FITNESS FOR A PARTICULAR PURPOSE (AND THEIR EQUIVALENTS UNDER THE LAWS OF ANY JURISDICTION), OR INFRINGEMENT OF ANY PATENT, COPYRIGHT OR OTHER INTELLECTUAL PROPERTY RIGHT.

UNLESS EXPRESSLY APPROVED IN WRITING BY AN AUTHORIZED ST REPRESENTATIVE, ST PRODUCTS ARE NOT RECOMMENDED, AUTHORIZED OR WARRANTED FOR USE IN MILITARY, AIR CRAFT, SPACE, LIFE SAVING, OR LIFE SUSTAINING APPLICATIONS, NOR IN PRODUCTS OR SYSTEMS WHERE FAILURE OR MALFUNCTION MAY RESULT IN PERSONAL INJURY, DEATH, OR SEVERE PROPERTY OR ENVIRONMENTAL DAMAGE. ST PRODUCTS WHICH ARE NOT SPECIFIED AS "AUTOMOTIVE GRADE" MAY ONLY BE USED IN AUTOMOTIVE APPLICATIONS AT USER'S OWN RISK.

Resale of ST products with provisions different from the statements and/or technical features set forth in this document shall immediately void any warranty granted by ST for the ST product or service described herein and shall not create or extend in any manner whatsoever, any liability of ST.

ST and the ST logo are trademarks or registered trademarks of ST in various countries.

Information in this document supersedes and replaces all information previously supplied.

The ST logo is a registered trademark of STMicroelectronics. All other names are the property of their respective owners.

© 2011 STMicroelectronics - All rights reserved

STMicroelectronics group of companies

Australia - Belgium - Brazil - Canada - China - Czech Republic - Finland - France - Germany - Hong Kong - India - Israel - Italy - Japan - Malaysia - Malta - Morocco - Philippines - Singapore - Spain - Sweden - Switzerland - United Kingdom - United States of America

www.st.com

