

Motor control with STM32® 32-bit ARM®-based MCU



STMicroelectronics

For 3-phase brushless motor vector drives

Vector control made simple

STMicroelectronics' STM32® offers the performance of the industry-standard Cortex™-M core at the service of vector (or field-oriented) control algorithms, widely used in high-performance drives. They provide precise and responsive torque and speed control, and guarantee optimized efficiency during transient operations.

The STM32, offering a wide and compatible portfolio, is part of a complete motor control ecosystem:

- 3-phase permanent magnet synchronous motor (PMSM) field-oriented control (FOC) firmware library
- Graphical configuration tool (MC Workbench)
- Graphical real-time diagnostic tool (STM Studio)
- Complete motor control kit

STM32 block diagram

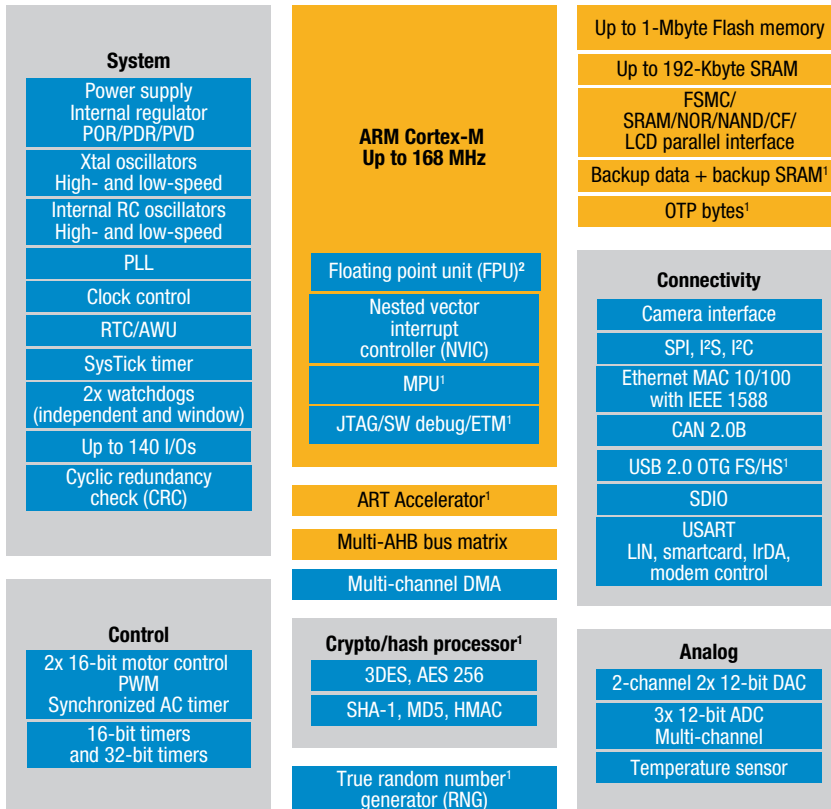

Applications

- Appliances
 - Washing machines
 - Dishwasher pumps
 - Refrigerators
 - Air conditioners
- Medical
 - Sleep apnea CPAP, VPAP
 - Wheel chairs
 - Pumps
- Industrial
 - Electric vehicles
 - Low-end and medium-range industrial drives
 - HVAC actuators and fans
 - Pumps
 - Blowers
 - Vending and cash machines

Notes:

1. STM32 F2 and F4 series
2. STM32 F4 series only

Field orientation in sensorless torque control – PMSM

Vector control drive

- Theory
 - Changing reference coordinates from fixed stator coils to the moving rotor frame greatly simplifies the equation describing the motor
- Method
 - Clarke and Park transformations convert variables with fixed 3-axis, 120° shifted coordinates into 2-axis orthogonal rotating coordinates
 - These last variables are DC, or slowly varying values, which can be regulated by means of simple PID controllers and then transformed back to the fixed stator windings frame using reverse transforms, as shown in the diagram below
- Requirements
 - Intensive math computations (trigonometric functions, multiple PID regulators, speed calculation)
 - Minimum resolution of 16 bits for the main control variables, with a need for 32-bit intermediate results, such as integral terms
 - Free CPU load must be kept for the remaining applicative tasks, such as communication and user interface

STM32 safety features for greater control robustness

Features

- Safety critical registers can be locked to prevent power stage damage (software runaway)
 - Deadtime, PWM output polarity, emergency input enable
- All target registers are read/write until lock activation (and then read-only if protected)
 - Once the two lock bits are written, they cannot be modified until next MCU reset (write-once bits)
- If main clock fails, an internal RC oscillator (FREEOSC, ~5 MHz average frequency) starts immediately
- Interrupt can be generated for shutdown or safe restart sequences
- Dual watchdog architecture with independent clock sources
- Embedded reset circuitry (power-on reset, power-down reset, programmable voltage detector)
- Emergency stop dedicated input pin with programmable state

Benefits

- Strengthens control algorithm to protect motor operation from external disturbance
- Protects safety-critical registers in case of system hang
- Quick error diagnosis and fault management
- Hardware protection of power stage whatever the status of MCU oscillator
- Safety hardware features comply with IEC 60335-1

Vector control block diagram of PMSM drive

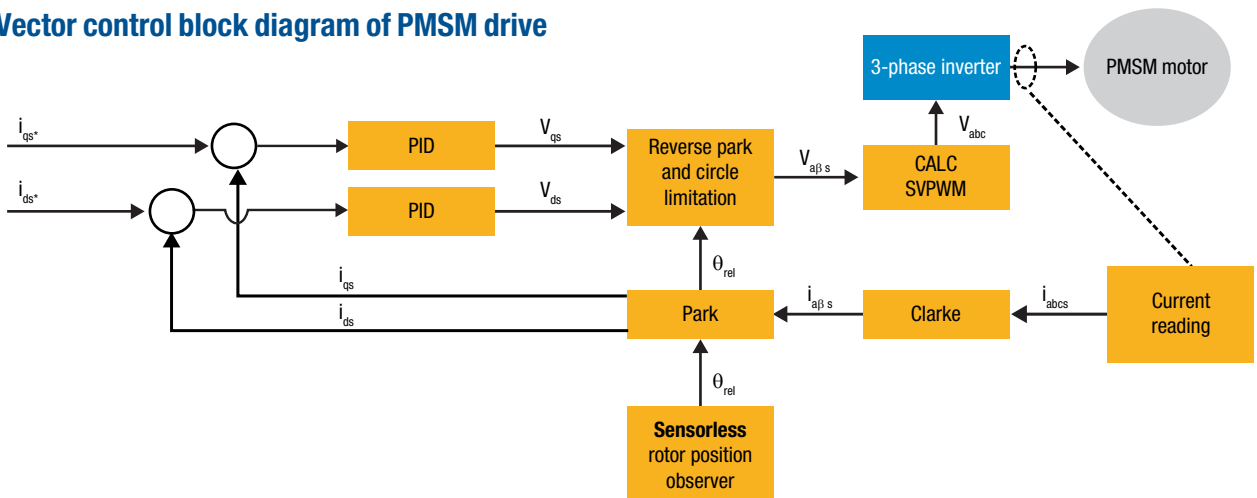

Notes:
 SVPWM: Space vector PWM
 * Target setting

Vector control with STM32

STM32 dedicated peripherals for 3-phase brushless motor control

PWM timer features

- Motor control timer clock
 - Maximum input clock is 72 MHz to provide 13.9 ns edge resolution (12-bit @ 16 kHz edge-aligned PWM with STM32 F1 series and up to 168 MHz (6.0 ns resolution) with the STM32 F4 series)
- Double-update mode
 - No loss of resolution in center-aligned mode
 - Uses an additional interrupt per PWM cycle or DMA transfers
- Burst mode
 - Possibility to update several registers of the peripheral using a single DMA stream
- Programmable reload rate
- Versatile PWM output management
 - Individually selectable polarities
 - Redirection circuitry for 6-step drives

- Programmable hardware deadtime generation
 - 8-bit register with 13.9 ns resolution at 72 MHz (F1 series) and 6.0 ns resolution at 168 MHz (F4 series)

ADC features

- Single/dual/triple ADC with simultaneous conversion mode
- 12-bit resolution
- Down to 0.5 μ s (F2 or F4 series) or 1 μ s (F1 series) conversion time
- Up to 24 channels, plus internal temperature sensor and V_{ref}
- External and internal trigger (including PWM timer)
- Versatile channel sequencer
- DMA capable
- Programmable sampling rate

Benefits

- Suitable for three-phase brushless PMSM or AC induction motors
- Sensor and sensorless configurations

Speed feedback

- Handled by the general-purpose timers
- Direct interface with incremental encoder and 1 to 3 Hall sensor logic outputs

Vector control implementation: hardware/software positioning

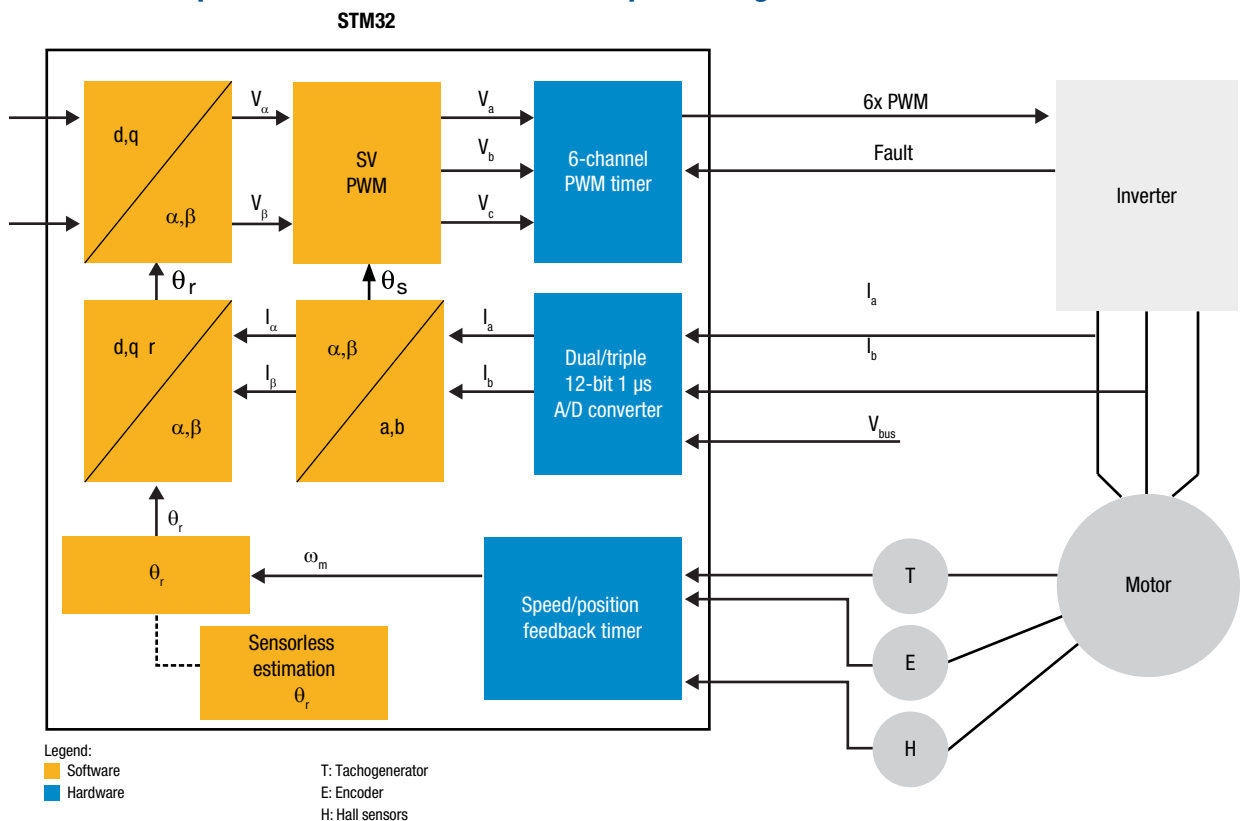

STM32 motor control kits

Run your motor in just a few steps

In just a few minutes, you can run the kit's PMSM synchronous motor with the standalone demo, in torque-control or speed-control mode, using the LCD on the STM32 evaluation control board (included in the kit).

You can then fine tune or change many parameters using the LCD user interface (as shown on LCD screen captures below) and run the PM synchronous motor, or an induction motor:

- Real-time tuning of torque, flux and speed PIDs
- B-EMF observer gain tuning (for sensorless control)
- Variation of target speed (speed control) or target torque and flux (torque control)
- Bus-voltage and power-stage temperature monitoring
- Selection of variables to put on output for DAC functionality implementation

You can apply changes to real-time settings to tune the drive parameters on-the-fly and get feedback values from the changed settings.

Once familiar with the demo, you will be able to explore our motor control library that supports FOC (field-oriented control) drive of PMSM and induction motors.

The library sources are free upon request, and help speed up development of motor control applications. With the free 32-Kbyte evaluation version of IAR's EWARM, you just open the libraries, develop the application, fine tune the code and parameters and compile. You can fine tune the application while running the motor using the real-time debugging capability of the Segger J-Link.

Application-specific requirements

Using the same hardware and firmware platform, you may incorporate application-specific requirements by taking advantage of the STM32 evaluation control board and the inverter board extension features (USART/LIN port, standalone operation potentiometer, wrapping area).

Flexibility

Other control and power boards are available and compatible with the kit. Future evaluation boards for motor control will also be compatible. For more information, contact your ST sales office.

STM32 FOC library

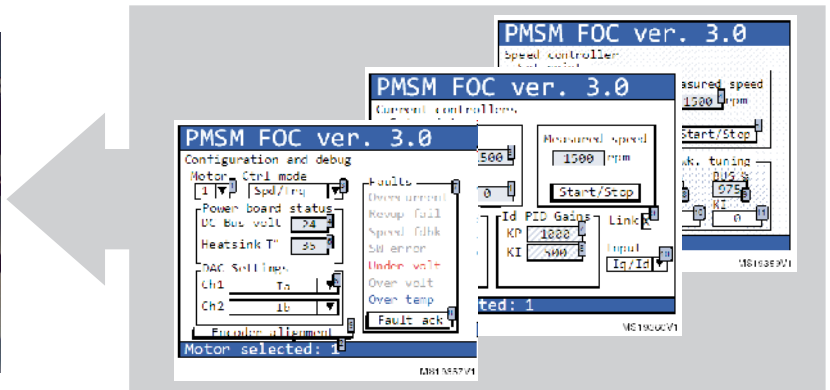
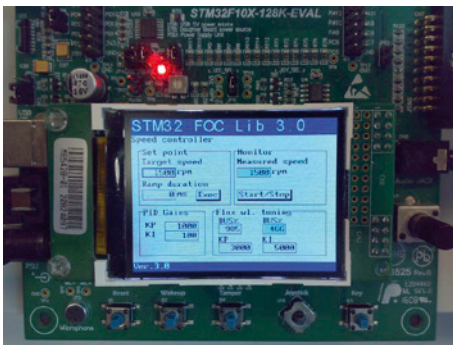

STM32 motor control kits

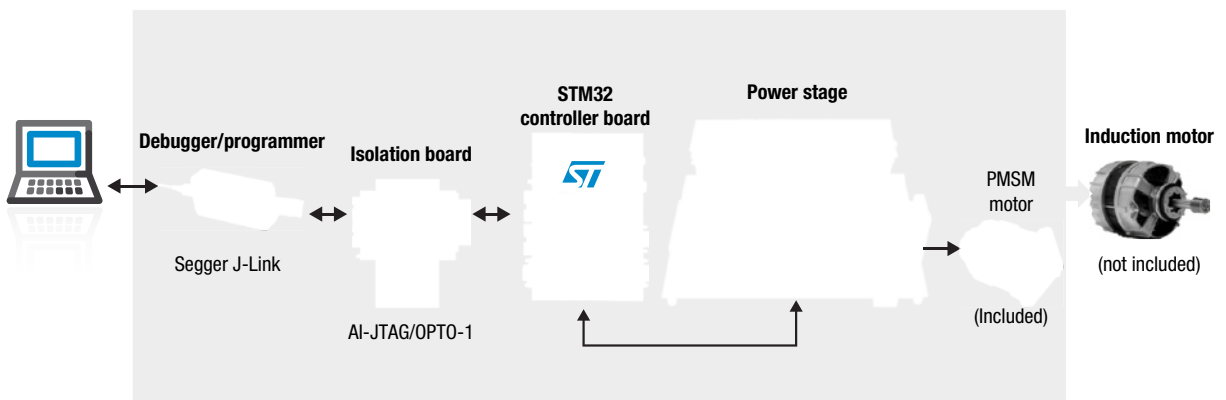

STM32 motor control kits

STM32 motor control tool ordering information

Part number	Description
AI-JTAG/OPTO-1	The isolation board included in the STM3210B-MCKIT can also be ordered separately. It provides galvanic isolation between the J-Link from Segger and any high-voltage target board. The isolation board has two JTAG connectors (in/out). Available from distributors and ST sales offices.
STM3210B-MCKIT*	Demonstration, evaluation and development kit for the STM32 includes firmware, LCD user interface, STM3210B-EVAL board (control board), 1 kW 3-phase inverter board, isolation board (AI-JTAG/OPTO-1), Segger J-Link debugger/programmer and 24 V _{DC} Shinano PMSM motor. Available from distributors and ST sales offices.
STM32100B-MCKIT*	Demonstration, evaluation and development kit for STM32 includes firmware, LCD user interface, STM32100B-EVAL board (control board), 1 kW 3-phase inverter board, isolation board (AI-JTAG/OPTO-1), Segger J-Link debugger/programmer and 24 V _{DC} Shinano PMSM motor. Available from distributors and ST sales offices.

Note:

* Dedicated motor-control documents are available upon request. Complementary control and power boards are available. Contact your ST sales office.

Vector control library

STM32 library

Optimized and documented C firmware libraries for control of both PMSM (sensor and sensorless mode) and AC induction (sensor mode) brushless motors are available for free upon request.

These libraries support IAR (EWARM), Keil and Greenhills toolchains.

By default the libraries are customized to run STM32-KIT. The source files are provided free of charge upon request. These libraries offer:

- Different current-sensing methodologies
 - Isolated current sensing
 - Three shunt resistors with dual sample and hold utilization and advanced methodology for better bus voltage exploitation
 - Proprietary algorithm for single shunt resistor
- Different rotor-position feedback
 - Tachometer (AC motor)
 - Hall sensors (60° and 120° placement)
 - Sensorless (PMSM motor only)

Total execution time of the field-oriented control in sensorless mode on the STM32 F1 series for PMSM motors is less than 21 μs (and below 10 μs with the new STM32F4). Total CPU load at 10 kHz sampling time is below 25 %; code size is less than 14 Kbytes.

Single-shunt current sensing

The STM32 motor control library supports single-shunt current sensing, for applications requiring lowest system costs. The proposed solution maximizes the DC bus voltage use, while minimizing current distortion and acoustical noise, and has been patented by ST. The STM32-MCKIT can be easily reconfigured in one-shunt mode, for evaluation purposes.

Internal permanent magnet motors (IPMSM)

As a result of their higher power density and very high speed capabilities, brushless IPMSM motors are used in an increasing number of designs compared to their surface-mounted magnet counterpart. The STM32 MC library supports this kind of motor with specific algorithms, such as MTPA (maximum torque per ampere) control strategy.

Dual motor control and triple ADC system

The high-density STM32 devices embed three ADCs and two motor control capable timers. This allows two brushless motors to be driven simultaneously, or to have a triple sample and hold current acquisition for very high-end control systems. These features are supported by additional interrupt vectors and a second DMA controller.

Field weakening and feed-forward control

The stator voltage closed-loop field weakening control implemented is able to expand the operating limits of both surface-mounted and internal PMSM, as many applications require. This algorithm strongly reduces sensitivity to motor parameters and environmental variations.

In addition, feed-forward control allows improved bus voltage ripple compensation and better current regulation during high-speed flux weakening operations.

Motor control development tools: what's new

A new motor control software library STM32 FOC PMSM SDK is now available.

- Based on the ARM's CMSIS compliant STM32 peripheral library
- Offering extended customizability
- Supporting latest members of the STM32 product line
- Full support of dual motor control drives (using any STM32F1 device)
- Including application example based on FreeRTOS

A field-oriented control dedicated GUI (ST Motor Control Workbench) provides help when configuring the motor control software library by means of:

- Clear configuration windows for the various items (including power stage, motor, speed and current feedbacks)
- Direct electrical-parameter entry, without need for conversion to fixed-point format
- Configuration header-file generation

Class B compliancy – how we help

Two key features help compliance with the EN/IEC 60335-1 norm: the dual watchdog architecture and the internal clock circuitry. In order to make certification even simpler with the STM32, a set of self-test routines has been developed to fulfill most of table H11.12.7 requirements. These routines have been certified by the VDE, a worldwide recognized test institute, and do not need to be re-evaluated if left unchanged.



Dual motor control

The STEVAL-IHM022V1 demonstration board is designed as a dual motor-control development platform for the STM32F103ZE microcontroller.

The board features full speed USB 2.0 and CAN 2.0 A/B compliant interfaces, 2x I²S, 2x I²C, 5x USART, 3x SPI, 2x DAC, internal 64-Kbyte SRAM and 512-Kbyte Flash memory, and JTAG and SWD debugging support.

The board is designed to implement multiple motor control (up to three MC connectors are available) and offers an advanced user I/O interface (LCD QVGA display and joystick key).

Demonstration software for the dual motor-control application is available upon request at ST sales offices.

Extension headers make it easy to connect a daughterboard or wrapping board for specific applications.

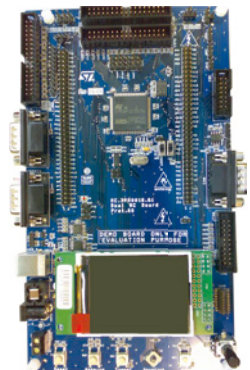

STEVAL-IHM022V1

STM Studio

STMicroelectronics' STM Studio is a graphical user interface which helps debug and diagnose STM32 applications, while they are running, by reading and displaying their variables in real time.

Running on a PC, STM Studio interfaces with STM32 MCUs via standard development tools, such as the low-cost ST-LINK and STX-RLINK.

STM Studio is a non-intrusive tool, preserving the real-time behavior of applications. STM Studio perfectly complements traditional debugging tools to fine tune applications, and is well suited for debugging applications that cannot be stopped, such as motor control applications.



Motor control and PFC

Digital power factor correction (PFC)

Why PFC?

For all motor-control applications, electric power efficiency increases the profitability of the application, and is a selling factor. A low power factor means poor electrical efficiency: PFC is an environment friendly technology, reducing the harmonics that create electrical pollution and saving energy to benefit the society as a whole.

The international norm IEC 61000-3-2 controls the harmonic content of the currents for appliances and electronic equipment up to 16 A.

Active or passive PFC?

While passive PFC is cheaper, active PFC can reach higher power factors (>98%). Passive PFC is also heavier and larger in size compared to active PFC.

Active PFC implementation with STM32

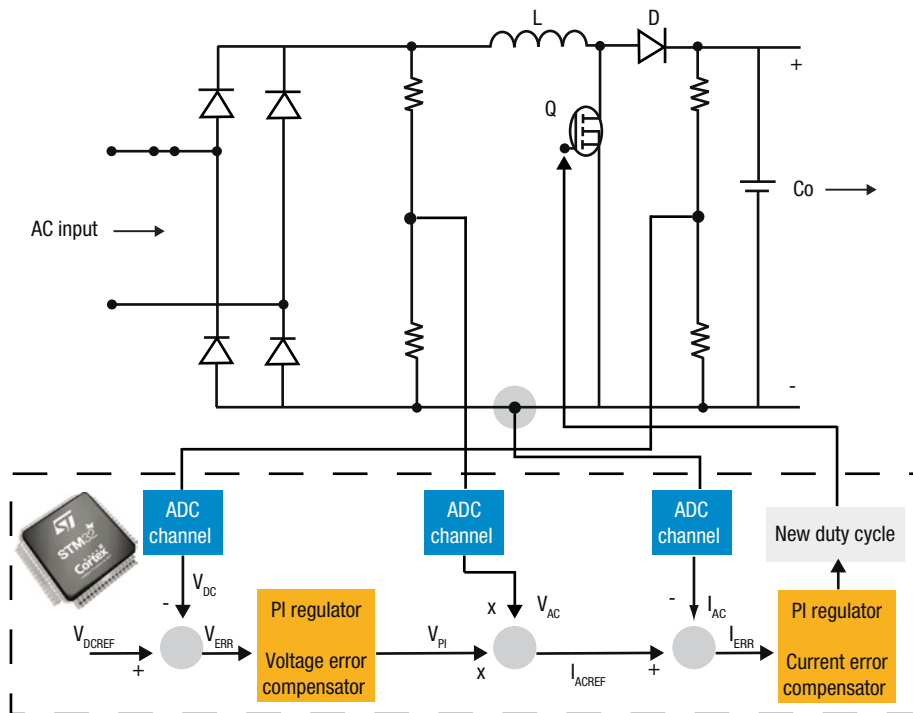

A demonstration software running a digital PFC and FOC drive with the STM32F103 is available upon request at ST sales offices.

