

Analog Signal Chain Guide

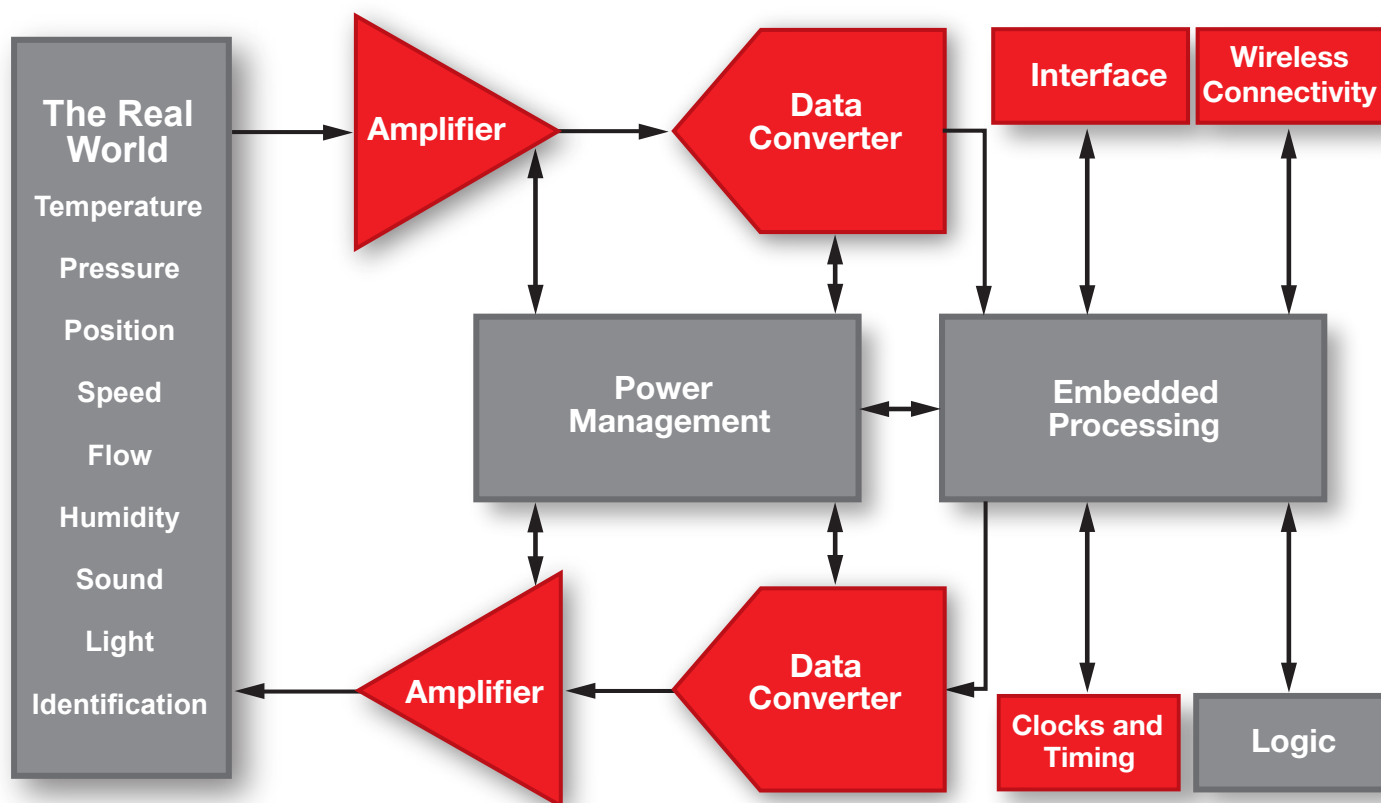

Amplifiers, Data Converters, Interface,
Clocks, Timing and Wireless Connectivity.



→ Table of Contents

Amplifiers and Comparators

Operational Amplifiers	4-10
High-Speed Amplifiers	11-17
Audio Amplifiers	18-25
Instrumentation Amplifiers	26-29
Power Amplifiers and Buffers	30
Comparators	31-32

Data Converters

Analog-to-Digital Converters (ADCs)	33
Delta-Sigma ADCs	33-36
SAR ADCs	37-45
Pipeline ADCs	46-51
Digital-to-Analog Converters (DACs)	52
String and R2R DACs	52-58
Current Steering DACs	59-60
Digital Potentiometers	61
Integrated ADCs and DACs	62
Audio Converters	63-67
Analog Front Ends	68
Medical	68-69
Imaging	70
Embedded Processors with Integrated ADCs	71

Monitoring and Control

Motor Drivers	72-76
Touch-Screen Controllers	77
Pulse-Width Modulation Power Drivers	78
Current Shunt Monitors	79-80
Temperature Sensors	81-82
4-20mA Transmitters	83

Voltage References

Voltage References	84
--------------------------	----

→ Table of Contents

Clocks and Timing

Clock Distribution	85-89
Clock Generation	90-93

Interface

Communications	94
LVDS/LVPECL/CML Repeaters, Translators and Crosspoints	94-95
LVD/MLVDS	96-97
SERDES	98-99
PECL-ECL Buffers/Translators	100
Consumer/Computing	101
Redriver/Equalizers	101
USB	102-104
1394	105-106
Display Port Switch/Redriver	107
Flatlink™ 3G Transmitter	108-109
PCI Express	110-111
HDMI	111
Industrial	112
CAN Transceivers	112
Digital Isolators	113-114
Ethernet Physical Layer Transceivers	115
SERDES	116
RS-485/RS-422	117-118
General	119
UARTs	119-120
ESD-EMI	121-122
I ² C	123-125
RS-232	126
Voltage-Level Translators	127

Radio Frequency

Broadband RF	128-129
Wireless Connectivity	130-134

Resources

Analog eLab™ Design Tools	135
-------------------------------------	-----

→ Operational Amplifiers

High Precision, 11MHz, Low Noise, RRO, JFET Operational Amplifier

OPA140, OPA2140, OPA4140

NEW

Get samples, datasheets and app reports at: www.ti.com/sc/device/PARTnumber (Replace **PARTnumber** with **OPA140**, **OPA2140**, or **OPA4140**)

Key Features

- Very low offset drift: $0.35\mu\text{V}/^\circ\text{C}$
- Very low offset: $120\mu\text{V}$ max
- Low input bias current: 10pA max
- Very low $1/f$ noise: 250nVpp , 0.1Hz to 10Hz
- Low noise: $5.1\text{nV}/\sqrt{\text{Hz}}$ at 1kHz
- Gain bandwidth: 11MHz
- Slew rate: $20\text{V}/\mu\text{s}$

Applications

- Battery-powered instruments
- Industrial controls
- Medical instrumentation
- Photodiode amplifiers
- Active filters
- Automatic test systems

The OPA140 family is a series of low-power JFET input amplifiers that feature good drift and low input bias current. The rail-to-rail output swing and input range that includes V^- allow designers to take advantage of the low noise characteristics of JFET amplifiers while also interfacing to modern, single-supply, precision ADCs and DACs. The OPA140 achieves 11MHz unity-gain bandwidth and a $20\text{V}/\mu\text{s}$ slew rate while consuming only 1.8mA (typ) of quiescent current.

0.1Hz to 10Hz NOISE

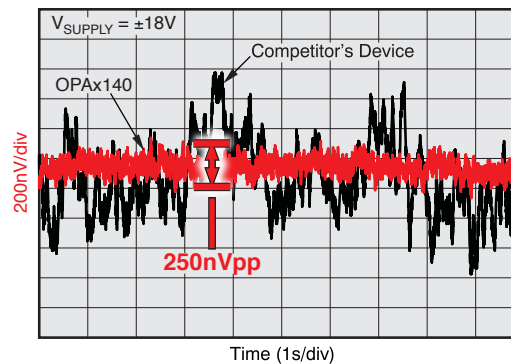

OPA140 illustration

5.5MHz, Low Noise, Low-Power, CMOS Operational Amplifier

OPA377, OPA2377, OPA4377

NEW

Get samples, datasheets and app reports at: www.ti.com/sc/device/PARTnumber (Replace **PARTnumber** with **OPA377**, **OPA2377**, or **OPA4377**)

Key Features

- Gain bandwidth product: 5.5MHz
- Low noise: $7.5\text{nV}/\sqrt{\text{Hz}}$ at 1kHz
- Offset voltage: 1mV (max)
- Input bias current: 0.2pA
- Rail-to-rail output
- Unity-gain stable
- EMI input filtering
- Quiescent current: $0.76\text{mA}/\text{ch}$
- Supply voltage: 2.2V to 5.5V
- Small packages: SC70, SOT-23, MSOP and DFN

Applications

- Photodiode preamps
- Piezoelectric sensor preamps
- Sensor signal conditioning
- Audio equipment
- Active filters

The OPA377 family of operational amplifiers are wide-bandwidth CMOS amplifiers that provide very low noise, low input bias current and low offset voltage while operating on a low quiescent current of 0.76mA (typ).

The OPA377 op amps are optimized for low-voltage, single-supply applications. The exceptional combination of AC and DC performance make them ideal for a wide range of applications, including small signal conditioning, audio and active filters. In addition, these parts have a wide supply range with excellent PSRR, making them attractive for applications that run directly from batteries without regulation.

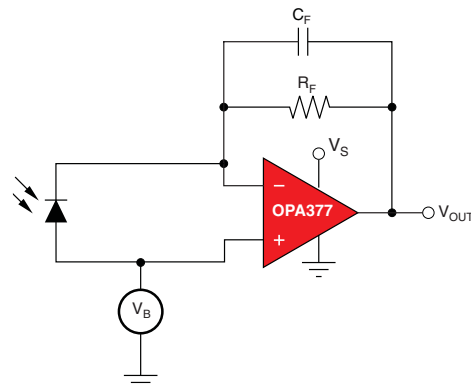

Photodiode preamplifier

Operational Amplifiers

36V, Low Power, RRO, General-Purpose Operational Amplifier in microPackages

OPA171, OPA2171, OPA4171

NEW

Get samples, datasheets and app reports at: www.ti.com/sc/device/PARTnumber (Replace **PARTnumber** with **OPA171**, **OPA2171**, or **OPA4171**)

Key Features

- MicroPackages:
 - Single in SOT553, dual in VSSOP-8
- Low quiescent current: 495µA/ch
- Low noise: 14nV/√Hz at 1kHz
- Rail-to-rail output
- Gain bandwidth: 3MHz
- Low input bias current: 8pA
- RFI filtered inputs
- Supply range: +2.7V to +36V, ±1.35V to ±18V

The OPA171 amplifier family is a series of 36V low-noise operational amplifiers that feature single supply, and micropackages with the ability to operate on supplies ranging from +2.7V (±1.35V) to +36V (±18V). They offer good offset, drift and bandwidth with low quiescent current. Single, dual and quad versions have identical specifications for maximum design flexibility. Unlike most op amps, which are specified at only one supply voltage, OPA171 op amps are specified from +2.7V to +36V. Input signals beyond the supply rails will not cause phase reversal.

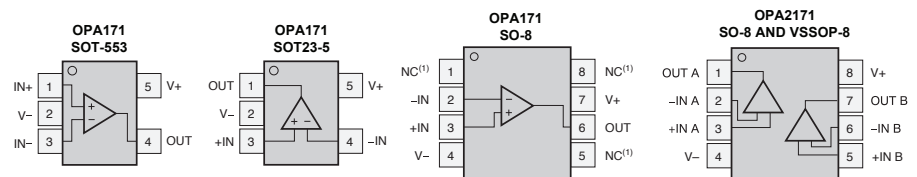

OPA171/2171 pin configurations

Applications

- Transducer amplifiers
- Bridge amplifiers
- Strain gage amplifiers
- Precision integrators
- Battery powered instruments
- Test equipment

2.2nV/√Hz, 18MHz, Precision, RRO, 36V Operational Amplifier

OPA209, OPA2209, OPA4209

NEW

Get samples, datasheets and app reports at: www.ti.com/sc/device/PARTnumber (Replace **PARTnumber** with **OPA209**, **OPA2209**, or **OPA4209**)

Key Features

- Gain bandwidth: 18MHz
- Slew rate: 6.4V/µs
- Input voltage noise: 2.2nV/√Hz at 1kHz
- Quiescent current: 2.5mA/ch max
- Low offset voltage: 150µV max
- Rail-to-rail output
- Packaging: SOT23-5, MSOP-8, SO-8, TSSOP-14

The OPA209 series of precision operational amplifiers achieves very low voltage noise density (2.2nV/√Hz) with a supply current of only 2.5mA (max). These amplifiers provide fast settling time to 16-bit accuracy even for 10V output swings in precision data acquisition applications. This excellent AC performance, combined with only 150µV (max) of offset and low drift over temperature, makes the OPA209 very suitable for fast, high-precision applications.

Applications

- PLL loop filters
- High performance ADC drivers
- High performance DAC output amplifiers
- Ultrasound amplifiers
- Infrared detector amplifiers
- Active filters

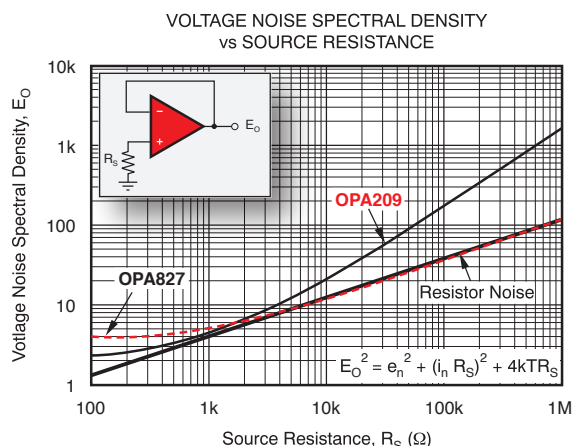

OPA209 schematic

→ Operational Amplifiers

Precision, 20MHz, 0.9pA I_B, Low Noise, RRIO, CMOS Operational Amplifier

NEW

OPA320, OPA2320

Get samples, datasheets and app reports at: www.ti.com/sc/device/PARTnumber (Replace **PARTnumber** with **OPA320**, or **OPA2320**)

Key Features

- Precision with zero-crossover distortion:
 - Low offset voltage: 150μV (max)
 - High CMRR: 114dB
 - Rail-to-Rail I/O
- Wide bandwidth: 20MHz
- Low noise: 8.5nV/√Hz at 1kHz
- Quiescent current: 1.45mA/ch
- Low input bias current: 0.9pA (max)
- Slew rate: 10V/μs
- Single supply voltage range: 1.8V to 5.5V

Applications

- High-Z sensor signal conditioning
- Transimpedance amplifiers
- Test and measurement equipment
- Programmable logic controllers (PLCs)
- Motor control loops
- Input/output ADC/DAC buffers
- Active filters

The OPA320 (single) and OPA2320 (dual) are precision, RRIO, CMOS operational amplifiers optimized for very low noise and wide bandwidth while operating on a low quiescent current of only 1.45mA/ch.

The OPA320 and OPA2320 combine a wide bandwidth and high slew rate (10V/μs) with low noise (7nV/√Hz), low offset, and less than 1pA maximum input bias current. These specifications make these devices ideal for a wide range of precision, time-and frequency-domain applications, such as high-impedance sensor front-ends, process control, or data acquisition systems.

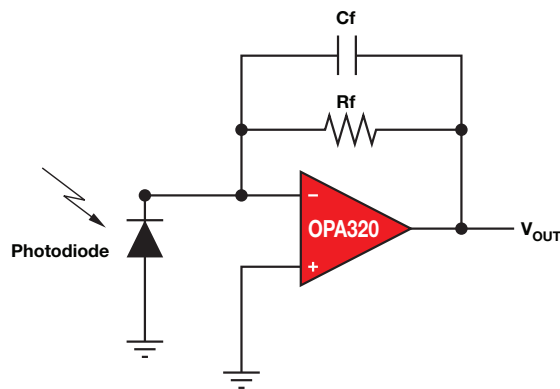

OPA320 diagram

Low Offset Voltage Operational Amplifiers (V_{OS} <500μV) (sorted by V_{OS})

Device	Description/Technology	Ch.	V _S (V) (min)	V _S (V) (max)	I _O Per Ch. (mA) (max)	GBW (MHz) (typ)	Slew Rate (V/μs) (typ)	V _{OS} (25°C) (mV) (max)	V _{OS} Drift (μV/°C) (typ)	I _B (pA) (max)	CMRR (dB) (min)	V _n at 1kHz (nV/√Hz) (typ)	Single Supply	Rail-to-Rail	HiRel Avail.	Package(s)	Price*
OPAy734/5	12V, Zero-Drift, SHDN, CMOS	1,2	2.7	12	0.75	1.6	1.5	0.005	0.01	200	115	135	Y	Out	N	SOT-23, SOIC	1.25
OPAy334/5	Zero-Drift, SHDN, CMOS	1,2	2.7	5.5	0.35	2	1.6	0.005	0.02	200	110	62	Y	Out	N	SOT-23, MSOP	1.00
OPAy333	Zero Drift, CMOS, μPower	1,2	1.8	5.5	0.025	0.35	0.16	0.01	0.02	200	106	55	Y	I/O	Y	SC-70, SOT-23, SOIC	0.95
OPAy277	High Precision, Low Power	1,2,4	4	36	0.825	1	0.8	0.02	0.1	1000	130	8	N	N	N	SON, SOIC	0.85
OPA177	Precision Operational Amplifier	1	6	36	2	0.6	0.3	0.025	0.1	2000	130	7.5	N	N	N	PDIP, SOIC	1.00
OPAy376	Precision, Low Noise, e-trim Series	1,2,4	2.2	5.5	0.95	5.5	2	0.025	0.32	10	76	7.5	Y	Out	N	SC-70, SOT-23	0.65
OPAy381	Precision, Low Power, High-Speed Transimpedance Amplifier	1,2	2.7	5.5	1	18	12	0.025	0.03	50	95	114	Y	Out	N	MSOP, SON	0.75
OPAy211	Bipolar, Ultra-Low Noise	1,2	4.5	36	4.5	45	27	0.05	0.15	125000	114	1.1	Y	Out	Y	MSOP, SOIC, SON	5.15
OPAy330	Low-Power, Zero-Drift, RRIO Operation Amplifier	1,2,4	1.8	5.5	0.035	0.35	0.16	0.05	0.02	500	100	55	Y	I/O	N	SC-70, SOT-23, SOIC, SON, VQFN, TSSOP	0.45
OPAy378	Zero-Drift, GBW 0.9MHz, Low I _O	1,2	1.8	5.5	0.125	0.9	0.4	0.05	0.1	500	100	20	Y	I/O	N	SC-70, SOT-23, SOIC	0.70
OPAy209	Low Noise, Low Power, 36V, Operational Amplifier in SOT-23	1,2,4	4.5	36	2.5	18	6.25	0.15	1	4500	120	2.2	Y	Out	N	SOT-23, MSOP, SOIC	0.95
OPAy227/28	Bipolar, Low Noise, Low IB	1,2,4	5	36	3.8	8,33	2.3,11	0.075	0.1	10000	120	3	N	N	N	SOIC, PDIP	1.10
TLE2027/37	Wide Supply, Low Noise, Bipolar	1	8	38	5.3	13,50	2.8,7.5	0.1	0.4	90000	100	2.5	N	N	Y	SOIC, PDIP	0.90
OPAy140	10MHz, Single-Supply, Low-Noise, JFET Precision Amplifier	1,2,4	4.5	36	2.0	11	20	0.12	0.35	10	120	5.1	Y	Out	N	SOIC, MSOP, TSSOP, SOT-23	1.55
OPAy211A	1.1nV/√Hz Noise, Low-Power, Precision Operational Amplifier	1,2	4.5	36	4.5	45	27	0.125	0.35	175000	114	1.1	Y	Out	N	MSOP, SOIC, SON	3.45
OPAx320	20MHz, Low-Noise, Low- Power, RRIO Precision CMOS	1,2	1.8	5.5	1.6	20	10	0.15	1.5	0.9	100	8.5	Y	I/O	N	MSOP, SON, SOT-23, SOIC	0.80

*Suggested resale price in U.S. dollars in quantities of 1,000. See www.ti.com/hirel for HiRel options.

New products are listed in bold red.

Amplifiers and Comparators

Operational Amplifiers

Low Offset Voltage Operational Amplifiers ($V_{OS} < 500\mu V$) (sorted by V_{OS}) (continued)

Device	Description/Technology	Ch.	V_S (V) (min)	V_S (V) (max)	I_Q Per Ch. (mA) (max)	GBW (MHz) (typ)	Slew Rate (V/ μ s) (typ)	V_{OS} (25°C) (mV) (max)	V_{OS} Drift (μ V/ $^{\circ}$ C) (typ)	I_B (pA) (max)	CMRR (dB) (min)	V_N at 1kHz (nV/ \sqrt Hz) (typ)	Single Supply	Rail-to-Rail	HiRel Avail.	Package(s)	Price*
OPAy336	μ Power, CMOS, Single Supply	1, 2, 4	2.3	5.5	0.032	0.1	0.03	0.125	1.5	10	80	40	Y	Out	Y	SOT-23, MSOP	0.40
OPAy727/8	e-trim, CMOS 12V, SHDN	1, 2, 4	4	12	6.5	20	30	0.15	0.3	500	86	23	Y	Out	N	MSOP, SON	0.60
OPAy827	Precision, Low Noise, JFET Input	1, 2	8	36	5.2	22	28	0.15	1	50	104	4	N	N	N	SOIC, MSOP	3.75
OPAy365	Zero-Crossover, Low V_{IO} and Drift	1, 2	2.2	5.5	5	50	25	0.2	1	10	100	4.5	Y	I/O	N	SOT-23, SOIC	0.65
OPAy241	Optimized for +5V Supply, High CMRR and A_{OL}	1, 2, 4	2.7	36	0.03	0.035	0.01	0.25	0.4	20000	80	45	Y	Out	N	SOIC, DIP	1.15
OPAy234	Low Power, Wide Supply, Bipolar	1, 2, 4	2.7	36	0.35	0.35	0.2	0.25	0.5	25000	91	25	N	Out	N	MSOP, SOIC	1.05
OPAy251	Single Supply +36V, High CMRR and A_{OL}	1, 2, 4	2.7	36	0.038	0.035	0.01	0.25	0.5	20000	100	45	Y	Out	N	SOIC, DIP	1.15
OPA627/37	Ultra-Low THD+N, Difet™	1	9	36	7.5	16, 80	55, 135	0.25	0.8	5	106	5.2	N	N	N	PDIP, SOIC	12.25
OPA124	Wide Bandwidth, Bipolar	1	10	36	3.5	1.5	1.6	0.5	2	2	94	8	N	N	N	SOIC	3.95
OPAy340	CMOS, Wide Bandwidth	1, 2, 4	2.7	5.5	0.95	5.5	6	0.5	2.5	10	80	25	Y	I/O	Y	MSOP, SOIC, SOT-23, SSOP, PDIP	0.90
OPAy363/4	1.8V, RRIO, High CMRR, Shutdown (0.9 μ A)	1, 2	1.8	5.5	0.75	7	5	0.5	3	10	74	17	Y	I/O	N	MSOP, SOIC, SOT-23	0.60
OPAy350	Excellent ADC Driver, Low Noise	1, 2, 4	2.5	5.5	7.5	38	22	0.5	4	10	74	18	Y	I/O	N	PDIP, MSOP, SOIC, SSOP	1.15

Low-Power Operational Amplifiers ($I_Q < 500\mu A$) (sorted by I_Q)

Device	Description	Ch.	V_S (V) (min)	V_S (V) (max)	I_Q Per Ch. (mA) (max)	GBW (MHz) (typ)	Slew Rate (V/ μ s) (typ)	V_{OS} (25°C) (mV) (max)	V_{OS} Drift (μ V/ $^{\circ}$ C) (typ)	I_B (pA) (max)	CMRR (dB) (min)	V_N at 1kHz (nV/ \sqrt Hz) (typ)	Single Supply	Rail-to-Rail	HiRel Avail.	Package(s)	Price*
TLV240x	2.5V, Sub- μ Power, SS, CMOS	1, 2, 4	2.5	16	0.00095	0.0055	0.0025	1.2	3	300	63	800	Y	I/O	N	MSOP, SOIC, SOT-23	0.65
OPAy369	1 μ A, SS, Zero Crossover, CMOS	1, 2	1.8	5.5	0.001	0.012	0.005	0.75	0.4	50	100	120	Y	I/O	N	SC-70, SOT-23, MSOP	0.65
TLV224x	Low Voltage, 1 μ A, SS, CMOS	1, 2, 4	2.5	12	0.0012	0.0055	0.002	3	3	500	55	500	Y	I/O	N	MSOP, SOIC, SOT-23	0.65
OPAy349	2 μ A, SS, CMOS	1, 2	1.8	5.5	0.002	0.07	0.02	10	15	10	52	300	Y	I/O	N	SC-70, SOIC, SOT-23	0.50
OPAy379	1.8V, Ultra-Low Power, CMOS	1, 2, 4	1.8	5.5	0.0055	0.09	0.03	1.5	2.7	50	90	80	Y	I/O	N	SC-70, SOT-23, SOIC	0.65
TLC27Lx	LinCMOS™ Low-Power Operational Amplifier	1, 2, 4	3	16	0.017	0.085	0.03	10	1.1	60	65	68	Y	N	Y	SOIC, PDIP	0.37
OPAy333	17 μ A, SS, RRIO, Zero-Drift, CMOS	1, 2	1.8	5.5	0.025	0.35	0.16	0.01	0.02	200	106	55	Y	I/O	Y	SC-70, SOT-23, SOIC	0.95
OPAy241	Optimized for +5V Supply, High CMRR and A_{OL}	1, 2, 4	2.7	36	0.03	0.035	0.1	0.25	0.4	20000	80	45	Y	Out	N	PDIP, SOIC	1.15
OPAy336	μ Power, SS, CMOS	1, 2, 4	2.3	5.5	0.032	0.1	0.03	0.125	1.5	10	80	40	Y	Out	Y	SOT-23, SOIC	0.40
OPAy347	μ Power, Low Cost, SS, CMOS	1, 2, 4	2.3	5.5	0.034	0.35	0.17	6	3	10	70	60	Y	I/O	N	SC-70, SOT-23, WCP	0.48
OPAy330	Low-Power, Zero-Drift, RRIO Operational Amplifier	1, 2, 4	1.8	5.5	0.035	0.35	0.16	0.05	0.02	500	100	55	Y	I/O	N	SC-70, SOT-23, SOIC, SON, VQFN, TSSOP	0.45
OPAy251	Single Supply +36V, High CMRR and A_{OL}	1, 2, 4	2.7	36	0.038	0.035	0.01	0.25	0.5	20000	100	45	N	Out	N	SOIC, PDIP	1.15
TLV245x	μ Power, SS, CMOS	1, 2, 4	2.7	6	0.042	0.22	0.11	1.5	0.3	5000	70	52	Y	I/O	N	SOT-23, SOIC, PDIP	0.60
OPAy244	μ Power, SS, Low Cost, Bipolar	1, 2, 4	2.2	36	0.06	0.43	0.1	1.5	4	25000	84	22	Y	Out	N	SOIC, SOT-23	0.55
OPAy348	High Open-Loop Gain, SS, CMOS	1, 2, 4	2.1	5.5	0.065	1	0.5	5	4	10	70	35	Y	I/O	N	SC-70, SOIC, SOT-23	0.25
OPAy378	Zero-Drift, GBW 0.9MHz, Low I_Q	1, 2	1.8	5.5	0.125	0.9	0.4	0.05	0.1	500	100	20	Y	I/O	N	SC-70, SOT-23	0.70
OPAy703/4	12V, RRIO, GBW 1MHz	1, 2, 4	4	12	0.2	1	0.6	0.75	4	10	70	45	Y	I/O	N	SOT-23, MSOP, SOIC	1.30
OPAy345	Wideband, Single Supply ($G > 5$)	1, 2, 4	2.5	5.5	0.25	3	2	1	3	10	76	32	Y	I/O	N	SOT-23, SOIC, MSOP	0.55

*Suggested resale price in U.S. dollars in quantities of 1,000. See www.ti.com/hirel for HiRel options.

New products are listed in bold red.

Amplifiers and Comparators

Operational Amplifiers

Low-Power Operational Amplifiers ($I_Q < 500\mu A$) (sorted by I_Q) (continued)

Device	Description	Ch.	V _S (V) (min)	V _S (V) (max)	I _Q Per Ch. (mA) (max)	GBW (MHz) (typ)	Slew Rate (V/ μ s) (typ)	V _{OS} (mV) (25°C) (max)	V _{OS} Drift (μ V/°C) (typ)	I _B (pA) (max)	CMRR (dB) (min)	V _N at 1kHz (nV/ \sqrt Hz) (typ)	Single Supply	Rail-to-Rail	HiRel Avail.	Package(s)	Price*
OPAy137	Low Cost, FET-Input	1, 2, 4	4.5	36	0.27	1	3.5	3	15	100	76	45	Y	N	N	SOT-23, SOIC, DIP	0.60
TLE202x	Precision Low-Power Single-Supply Operational Amplifier	1, 2, 4	4	40	0.3	1.2	0.5	0.6	2	70000	85	17	Y	N	Y	PDIP, TSSOP	0.45
OPAy234	Low Power, Precision	1, 2, 4	2.7	36	0.35	0.35	0.2	0.25	0.5	25000	91	25	Y	Out	N	MSOP, SOIC	1.05
OPAy334/5	Zero Drift, CMOS, SS, SHDN	1, 2	2.7	5.5	0.35	2	1.6	0.005	0.02	200	110	62	Y	Out	N	MSOP, SOIC, SOT-23	1.00
OPAy171	36V Single-Supply, Low-Noise CMOS Amplifier in SOT553	1, 2, 4	2.7	36	0.595	3	1.5	1.8	0.3	15	104	14	Y	Out	N	SOT553, SOT-23, SOIC, VSSOP, TSSOP	0.40

Low-Noise Operational Amplifiers ($V_N \leq 10\text{nV}/\sqrt{\text{Hz}}$) (sorted by V_N)

Device	Description/Technology	Ch.	V _S (V) (min)	V _S (V) (max)	I _Q Per Ch. (mA) (max)	GBW (MHz) (typ)	Slew Rate (V/ μ s) (typ)	V _{OS} (mV) (25°C) (max)	V _{OS} Drift (μ V/°C) (typ)	I _B (pA) (max)	CMRR (dB) (min)	V _N at 1kHz (nV/ \sqrt Hz) (typ)	Single Supply	Rail-to-Rail	HiRel Avail.	Package(s)	Price*
OPA161x	High Performance, Bipolar Input, Audio Amp	1, 2	4.5	36	4.5	80	27	0.5	—	175000	110	1	N	N	N	SOIC	1.75
OPAy211	Bipolar, Ultra-Low Noise	1, 2	4.5	36	4.5	80	27	0.125	0.35	175000	114	1.1	Y	Out	Y	MSOP, SOIC, SON	5.15
OPAy211A	1.1nV/ \sqrt Hz Noise, Low-Power, Precision Operational Amplifier	1, 2	4.5	36	4.5	45	27	0.125	0.35	175000	114	1.1	Y	Out	N	MSOP, SOIC, SON	3.45
OPAy209	Low-Noise, Low-Power, 36V, Operational Amplifier in SOT-23	1, 2, 4	4.5	36	2.5	18	6.25	0.15	1	4500	120	2.2	Y	Out	N	SOT-23, MSOP, SOIC, TSSOP	0.95
TLE2027	Low-Noise Precision Operational Amplifier	1	8	38	5.3	13	2.8	0.1	0.4	90000	100	2.5	N	N	Y	SOIC, PDIP	0.90
OPAy227/8	Precision, Low Noise, G _v ≥5 Bipolar	1, 2, 4	5	36	3.8	8	2.3	0.075	0.1	10000	120	3	N	N	N	PDIP, SOIC	1.10
OPAy827	Ultra-Low THD+N, High Precision, Low Noise, JFET	1, 2	8	36	5.2	22	28	0.15	1	50	104	4	N	N	N	MSOP, SOIC	3.75
OPAy140	10MHz, Single Supply, Low Noise, JFET Precision Amplifier	1, 2, 4	4.5	36	2.0	11	20	0.12	0.35	10	120	5.1	Y	Out	N	SOIC, MSOP, TSSOP, SOT-23	1.55
OPA627	Ultra-Low THD+N, Difet™ Unit	1	9	36	7.5	16	55	0.25	0.8	5	106	5.2	N	N	N	PDIP, SOIC	12.25
OPAy141	10MHz, Single-Supply, Low-Noise, JFET Precision Amplifier	1, 2, 4	4.5	36	2.3	10	20	3.5	2	20	120	6.5	Y	Out	N	MSOP, SOIC, TSSOP	0.85
TLC07xA	Wide-Bandwidth, High-Output-Drive Op Amp Family	1, 2, 4	4.5	16	2.5	10	16	1.4	1.2	50	80	7	Y	N	N	PDIP, SOIC, HTSSOP	0.65
OPA177	Precision Operational Amplifier	1	6	36	2	0.6	0.3	0.025	0.1	2000	130	7.5	N	N	N	PDIP, SOIC	1.00
OPAy376	Low Offset, 5.5MHz, ADC Buffer	1, 2, 4	2.2	5.5	0.95	5.5	2	0.025	0.26	10	76	7.5	Y	I/O	N	SC-70, SOT-23, MSOP, SOIC, TSSOP	0.65
OPAy377	Low-Cost, Low-Noise, 5.5MHz CMOS Operational Amplifier	1, 2, 4	2.2	5.5	1.05	5.5	2	1	0.26	10	70	7.5	Y	Out	N	SC-70, SOT-23, SOIC, TSSOP	0.40
OPAy277	High Precision, Low Power	1, 2, 4	4	36	0.825	1	0.8	0.02	0.1	1000	130	8	N	N	N	SON, SOIC, PDIP	0.85
OPA124	Low Noise, Precision, Bipolar	1	10	36	3.5	1.5	1.6	0.5	2	2	94	8	N	N	N	SOIC	3.95
TLC220x	Precision, Low Noise, LinCMOSTM	1, 2	4.6	16	1.5	1.9	2.7	0.5	0.5	100	90	8	Y	Out	Y	SOIC, PDIP, SO	1.65
OPAy132	Wide Bandwidth, FET Input	1, 2, 4	5	36	4.8	8	20	0.5	2	50	96	8	N	N	N	PDIP, SOIC	1.45
TLC227x	Low-Noise Rail-to-Rail Operational Amplifier	2, 4	4.4	16	1.5	2.18	3.6	2.5	2	60	70	9	Y	Out	Y	PDIP, SOIC, TSSOP	0.70
OPA121	Precision, Difet Unit	1	10	36	4.5	2	2	3	3	10	82	10	N	N	N	SOIC	5.10

*Suggested resale price in U.S. dollars in quantities of 1,000. See www.ti.com/hirel for HiRel options.

New products are listed in **bold red**. Preview products are listed in **bold blue**.

Amplifiers and Comparators

Operational Amplifiers

Low Input Bias Current Operational Amplifiers ($I_B \leq 10\text{pA}$) (sorted by I_B)

Device	Description/Technology	Ch.	V_S (V) (min)	V_S (V) (max)	I_O Per Ch. (mA) (max)	GBW (MHz) (typ)	Slew Rate (V/ μ s) (typ)	V_{OS} (25°C) (mV) (max)	V_{OS} Drift (μ V/°C) (typ)	I_B (pA) (max)	CMRR (dB) (min)	V_N at 1kHz (nV/ $\sqrt{\text{Hz}}$) (typ)	Single Supply	Rail-to-Rail	HiRel Avail.	Package(s)	Price*
OPA129	Ultra-Low Bias, Difet™ Unit	1	10	36	1.8	1	2.5	2	3	0.1	0.1	80	N	N	N	SOIC	3.20
OPAx320	20MHz, Low-Noise, RRIO Precision CMOS	1,2	1.8	5.5	1.6	20	10	0.14	5	1	114	7	Y	I/O	N	MSOP, SON, SOT-23, SOIC	0.80
OPA124	Low Noise, High Precision	1	10	36	3.5	1.5	1.6	0.5	2	2	94	8	N	N	N	PDIP	3.95
OPA602	High-Speed, Precision, Difet Operation Amplifier	1	10	36	4	6.5	35	1	3	2	88	13	N	N	N	PDIP, SOIC	3.80
OPA627	Ultra-Low THD+N, Difet Unit	1	9	36	7.5	16	55	0.25	0.8	5	106	5.2	N	N	N	PDIP, SOIC	12.25
OPAy300/1	Low Noise, 16-Bit Accurate, Shutdown (10 μ A)	1,2	2.7	5.5	12	150	80	5	2.5	5	66	38	Y	Out	N	SOT-23, MSOP, SOIC	0.75
OPAy140	10MHz, Low-Noise, JFET Precision Amplifier	1,2,4	4.5	36	2.0	11	20	0.12	0.35	10	120	5.1	Y	Out	N	SOT-23, SOIC, MSOP, TSSOP	1.55
OPAy377	Low-Cost, Low-Noise, 5.5MHz CMOS Op Amp	1,2,4	2.2	5.5	1.05	5.5	2	1	0.26	10	70	7.5	Y	Out	N	SC-70, SOT-23, SOIC, TSSOP	0.40
OPAy376	Low Offset, 5MHz, e-trim General Purpose	1,2,4	2.2	5.5	0.95	5.5	2	0.025	0.26	10	76	7.5	Y	Out	N	SC-70, SOT-23, MSOP, SOIC, TSSOP	0.65
OPAy365	High Speed, Zero Cross Over, CMOS	1,2	2.2	5.5	5	50	25	0.2	1	10	100	13	Y	I/O	Y	SOT-23, SOIC	0.65
OPAy336	SS, μ Power, CMOS	1,2,4	2.3	5.5	0.032	0.1	0.03	0.125	1.5	10	80	40	Y	Out	Y	SOT-23, MSOP, SSOP, SOIC, PDIP	0.40
OPAy340	CMOS, Wide Bandwidth	1,2,4	2.7	5.5	0.95	5.5	6	0.5	2.5	10	80	25	Y	I/O	Y	MSOP, SOIC, SOT-23, SSOP, PDIP	0.90
OPAy363/4	1.8V, RRIO, High CMRR, Shutdown (0.9 μ A)	1,2	1.8	5.5	0.75	7	5	0.5	3	10	74	17	Y	I/O	N	MSOP, SOIC, SOT-23	0.60
OPAy344	Low Power, RRIO, SS	1,2,4	2.5	5.5	0.25	1	0.8	1	3	10	76	32	Y	I/O	N	SOT-23, MSOP, TSSOP, SOIC, PDIP	0.45
OPAy350	Excellent ADC Driver, Low Noise	1,2,4	2.5	5.5	7.5	38	22	0.5	4	10	74	18	Y	I/O	N	PDIP, MSOP, SOIC, SSOP	1.15
OPAy703/4	12V, Low Power, SHDN, CMOS	1,2,4	4	12	0.2	3	3	0.75	4	10	80	45	Y	I/O	N	MSOP, SOIC, PDIP	1.30
OPAy743	12V, 7MHz, CMOS	1,2,4	3.5	12	1.5	7	10	7	8	10	70	30	Y	I/O	N	MSOP, SOT-23, SOIC, PDIP	1.00

Wide-Bandwidth Precision Operational Amplifiers (GBW >5MHz) (sorted by GBW)

Device	Description/Technology	Ch.	V_S (V) (min)	V_S (V) (max)	I_O Per Ch. (mA) (max)	GBW (MHz) (typ)	Slew Rate (V/ μ s) (typ)	V_{OS} (25°C) (mV) (max)	V_{OS} Drift (μ V/°C) (typ)	I_B (pA) (max)	CMRR (dB) (min)	V_N at 1kHz (nV/ $\sqrt{\text{Hz}}$) (typ)	Single Supply	Rail-to-Rail	HiRel Avail.	Package(s)	Price*
OPAy211	Bipolar, Ultra-Low Noise	1,2	4.5	36	4.5	80	27	0.125	0.35	175000	114	1.1	Y	Out	Y	MSOP, SOIC, SON	5.15
OPAy365	High Speed, Zero Crossover, CMOS	1,2	2.2	5.5	5	50	25	0.2	1	10	100	13	Y	I/O	Y	SOT-23, SOIC	0.65
TLE2037	Low-Noise High-Speed Precision Operational Amplifier	1	8	38	5.3	50	7.5	0.1	0.4	90000	100	2.5	N	N	Y	SOIC, PDIP	0.90
OPAy350	Excellent ADC Driver, Low Noise	1,2,4	2.5	5.5	7.5	38	22	0.5	4	10	74	18	Y	I/O	N	PDIP, MSOP, SOIC, SSOP	1.15
OPAy228	Precision, Low Noise, G = 5, Bipolar	1,2,4	5	36	3.8	33	11	0.075	0.1	10000	120	3	N	N	N	PDIP, SOIC	1.10
OPAy827	Ultra-Low THD+N, High Precision	1,2	8	36	5.2	22	28	0.15	1	50	104	4	N	N	N	MSOP, SOIC	3.75
OPAx320	20MHz, Low-Noise, RRIO Precision CMOS	1,2	1.8	5.5	1.6	20	10	0.15	1.5	0.9	100	8.5	Y	I/O	N	MSOP, SON, SOT-23, SOIC	0.80
OPAy727/8	20MHz, e-trim Precision CMOS	1,2,4	4	12	6.5	20	30	0.15	0.3	500	86	23	Y	N	N	MSOP, SON	0.95
OPAy725/6	12V CMOS Op Amp	1,2	4	12	5.5	20	30	3	4	200	94	23	Y	Out	N	SOT-23, SOIC, MSOP	0.60

*Suggested resale price in U.S. dollars in quantities of 1,000. See www.ti.com/hirel for HiRel options.

New products are listed in bold red. Preview products are listed in bold blue.

Amplifiers and Comparators

Operational Amplifiers

Wide-Bandwidth Precision Operational Amplifiers (GBW >5MHz) (sorted by GBW) (continued)

Device	Description/Technology	Ch.	V _S (V) (min)	V _S (V) (max)	I _O Per Ch. (mA) (max)	GBW (MHz) (typ)	Slew Rate (V/μs) (typ)	V _{OS} (25°C) (mV) (max)	V _{OS} Drift (μV/°C) (typ)	I _B (pA) (max)	CMRR (dB) (min)	V _n at 1kHz (nV/√Hz) (typ)	Single Supply	Rail-to-Rail	HiRel Avail.	Package(s)	Price*
OPAy209	Low-Noise, Low-Power, 36V Operational Amplifier in SOT-23	1, 2, 4	4.5	36	2.5	18	6.25	0.15	1	4500	120	2.2	Y	Out	N	SOT-23, MSOP, SOIC	0.95
OPA627	Ultra-Low THD+N, Difet™ Unit	1	9	36	7.5	16	55	0.25	0.8	5	106	5.2	N	N	N	PDIP, SOIC	12.25
TLE2027	Low-Noise Precision Operational Amplifier	1	8	38	5.3	13	2.8	0.1	0.4	90000	100	2.5	N	N	Y	SOIC, PDIP	0.90
OPAy140	11MHz, Precision, Low-Noise, JFET Amplifier	1, 2, 4	4.5	36	2.0	11	20	0.12	0.35	10	120	5.1	Y	Out	N	SOT-23, SOIC, MSOP, TSSOP	1.55
OPAy141	10MHz, Single-Supply, Low-Noise JFET Amplifier	1, 2, 4	4.5	36	2.3	10	20	3.5	2	20	120	6.5	Y	Out	N	MSOP, SOIC, TSSOP	0.85
TLC08x	Low Noise, Wide Bandwidth, Bipolar	1, 2, 4	4.5	16	2.5	10	16	1.4	1.2	50	80	8.5	Y	N	Y	MSOP, SOIC, PDIP	0.45
OPAy132	Wide Bandwidth, FET Input	1, 2, 4	5	36	4.8	8	20	0.5	2	50	96	8	N	N	N	PDIP, SOIC	1.45
OPAy227	Precision, Low Noise, Bipolar	1, 2, 4	5	36	3.8	8	2.3	0.075	0.1	10000	120	3	N	N	N	PDIP, SOIC	1.10
OPAy743	12V, 7MHz, CMOS	1, 2, 4	3.5	12	1.5	7	10	7	8	10	70	30	Y	I/O	N	MSOP, SOT-23, SOIC, PDIP	1.00
OPAy363/4	1.8V, RRIO, High CMRR, Shutdown (0.9μA)	1, 2	1.8	5.5	0.75	7	5	0.5	3	10	74	17	Y	I/O	N	MSOP, SOIC, SOT-23	0.60
TLE214x	Widest Supply, Low Noise	1, 2, 4	4	44	4.5	6	42	0.5	1.7	1500000	85	10.5	Y	N	Y	TSSOP, PDIP, SOIC	0.55
OPAy340	CMOS, Wide Bandwidth	1, 2, 4	2.7	5.5	0.95	5.5	6	0.5	2.5	10	80	25	Y	I/O	Y	MSOP, SOIC, SOT-23, SSOP, PDIP	0.90
OPAy376	Precision, Low-Noise, Low I _O Operational Amplifier	1, 2, 4	2.2	5.5	0.95	5.5	2	0.025	0.26	10	76	7.5	Y	Out	N	SC-70, SOT-23, MSOP, SOIC, TSSOP	0.65
OPAy377	Low-Noise, 5.5MHz CMOS Operational Amplifier	1, 2, 4	2.2	5.5	1.05	5.5	2	1	0.26	10	70	7.5	Y	Out	N	SC-70, SOT-23 SOIC, TSSOP	0.40

General Purpose Amplifiers

Device	Ch.	V _S (V) (min)	V _S (V) (max)	I _O (25°C) Per Ch. (mA) (max)	V _{IO} (25°C) (mV) (max)	A Grade	I _B (nA) (temp) (max)	GBW (MHz) (typ)	Slew Rate (V/μS) (typ)	CMRR (dB) (min)	V _n (1kHz) (nV/√Hz)	HiRel Avail.	Packages	Standard Price*	'A' Grade Price*
LM358	2	3	32	0.6	7	3	500	0.7	0.3	65	40	N	PDIP, SOIC, SOP, TSSOP, MSOP/VSSOP	0.12	0.13
LM324	4	3	32	0.3	7	3	500	1.2	0.5	65	35	N	PDIP, SOIC, SOP, TSSOP	0.12	0.16
LM2904	2	3	26	0.6	7	2	500	0.7	0.3	50	40	Y	PDIP, SOIC, SOP, TSSOP, MSOP/VSSOP	0.12	0.23
LM2902	4	3	26	0.3	7	2	500	1.2	0.5	50	35	Y	PDIP, SOIC, SOP, TSSOP	0.12	0.28

Standard Linear Amplifiers

Device	Ch.	V _S (V) (min)	V _S (V) (max)	I _O (25°C) Per Ch. (mA) (max)	V _{IO} (25°C) (mV) (max)	I _B (nA) (temp) (max)	GBW (MHz) (typ)	Slew Rate (V/μS) (typ)	CMRR (dB) (min)	V _n (1kHz) (nV/√Hz)	Rail-to-Rail	Shut Down	HiRel Avail.	Packages	Price*
LMV321	1												Y	SC-70, SOT-23,	0.26
LMV358	2	2.7	5.5	0.17	7	500	1.0	1.0	50	39	Out	No	Y	MSOP/VSSOP,	0.30
LMV324	4												Y	SOIC, TSSOP	0.30
LMV324S	4	2.7	5.5	0.17	7	500	1.0	1.0	50	39	Out	Yes	N	SOIC, TSSOP	0.36
LMV931	1												Y	SC-70, SOT-23,	0.29
LV932	2	1.8	5.0	0.21	4	75	1.5	0.42	60	50	I/O	No	N	MSOP/VSSOP,	0.41
LMV934	4												Y	SOIC, TSSOP	0.42
LMV981	1												N	SC-70, SOT-23,	0.55
LMV982	2	1.8	5.0	0.21	4	75	1.5	0.42	60	50	I/O	Yes	N	MSOP/VSSOP	0.55

*Suggested resale price in U.S. dollars in quantities of 1,000. See www.ti.com/hirel for HiRel options.

New products are listed in bold red.

Amplifiers and Comparators

→ High-Speed Amplifiers (>50MHz)

High-Speed, Fully Differential Programmable Amplifiers

PGA870

NEW

Get samples, datasheets and application reports at: www.ti.com/sc/device/PGA870

Key Features

- Wideband: 650MHz -3dB bandwidth
- Low impedance, voltage-mode output
- High linearity: OIP3 = 47dBm at 100MHz
- HD2: -93dBc at 100MHz
- HD3: -88dBc at 100MHz
- IMD3: -99dBc at f1=90MHz, f2=100MHz
- Slew rate: 2800V/ μ s
- Wide adjustable gain range:
-11.5dB to +20dB
- 0.5dB gain resolution control
- Fast gain switching time: 3ns

Applications

- Programmable gain IF amplifiers
- CDMA/WCDMA (3G) base station receivers
- Fully differential 12/14/16-bit ADC drivers
- High IF sampling receivers
- Wideband multichannel receivers
- Test and measurement
- High-speed digitizer cards

The PGA870 is a high-speed, fully differential, 14-bit ADC driver with a Digital Variable Gain Amplifier (DVGA). The PGA870 offers low distortion, a wide gain range (-11.5dB to +20dB), and very fast gain switching time, making it suitable for fast gain control loop applications in 3G/4G radios. The PGA870 DVGA can be used for high-speed data conversion applications that require 14-bit ADC performance with adjustable gain on the inputs to the ADC. The PGA870 was designed with a voltage-mode output to improve gain flatness in the pass band and eliminate the need for output inductors, thereby lowering BOM costs.

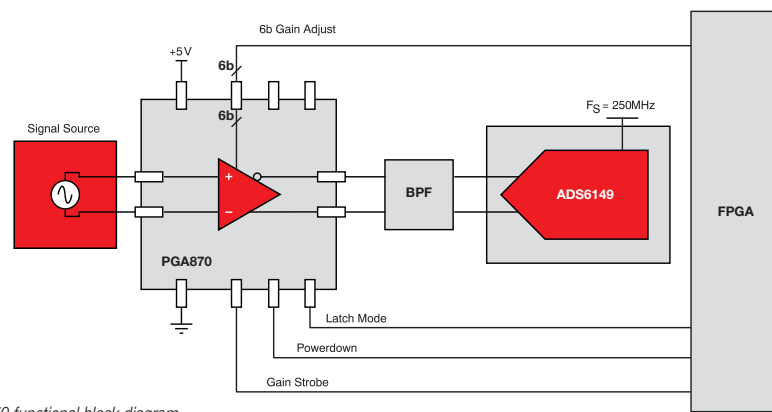

PGA870 functional block diagram

Single, Dual and Quad Fully Differential Amplifiers

THS4521, THS4522, THS4524

Get samples, datasheets and application reports at: www.ti.com/sc/device/PARTnumber

(Replace **PARTnumber** with **THS4521**, **THS4522** or **THS4524**)

Key Features

- Quiescent current: 1.14mA/ch
- Input voltage noise: 5nV/ $\sqrt{\text{Hz}}$
- Slew rate: 490V/ μ s
- Negative rail-input and rail-to-rail output
- Common-mode control
- Bandwidth: 150MHz
- Packages: SO-8 and MSOP-8 (single), TSSOP-16 (dual) and TSSOP-38 (quad)

Applications

- SAR or $\Delta\Sigma$ ADC drivers
- Low-power data acquisition systems
- High density MRI/CAT front end
- Portable instruments

The THS4521 (single), THS4522 (dual) and THS4524 (quad) are negative-rail input, rail-to-rail output, fully differential amplifiers operating from a single +2.7 to +5V supply. The low 1mA/channel quiescent current and power down capability to 1 μ A makes it a good choice for low power applications. The output common-mode control with low offset and drift allows for DC-coupling in high-accuracy data acquisition systems.

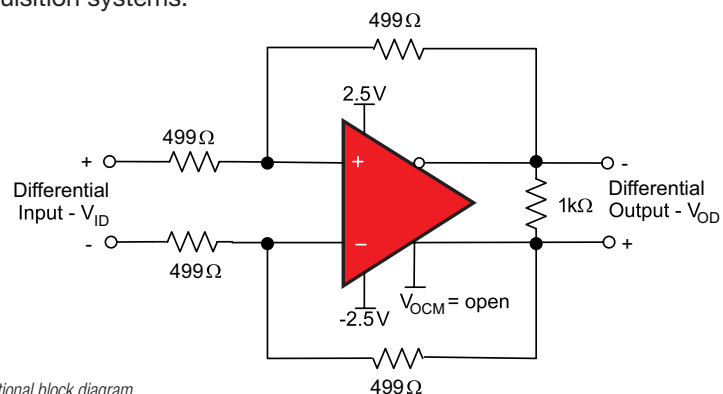

THS452x functional block diagram

Amplifiers and Comparators

→ High-Speed Amplifiers (>50MHz)

Low Noise, Fully Differential Operational Amplifier with +6dB Gain

THS770006

NEW

Get samples, datasheets and EVMs at: www.ti.com/sc/device/THS770006

Key Features

- Fully differential wideband operation:
 - 2.4GHz small signal bandwidth
 - 675MHz large signal bandwidth
- Low distortion: IMD3 of -107dBc at 100MHz, 2Vpp
- High linearity: OIP3 of 48dBm at 100MHz, 2Vpp
- Low voltage noise at flatband ($f > 100\text{kHz}$): $1.7\text{ nV}/\sqrt{\text{Hz}}$
- Fast overdrive recovery: 7.5ns max
- Single supply +5V operation
- Low impedance, voltage-mode output
- Quiescent current: 100mA, power-down <3mA
- 4mm x 4mm QFN pkg w/thermal pad

Applications

- 12-/14-/16-bit ADC driver/IF amps
- Wireless infrastructures
- High speed digitizers
- Military countermeasures
- Defense signal intelligence

The THS770006 is a low-noise, fully differential operational amplifier that provides the high linearity and dynamic range performance required for driving 14- and 16-bit ADCs, in high IF architectures, for wireless infrastructure, test and measurement, and defense applications. The THS770006 will support 16 bits of full-scale (3Vp-p) precision up to 200MHz IF in order to drive high-speed ADCs with very low distortion. The THS770006 provides the dynamic range performance that is compatible with 16-bit high-speed signal chains, with lower distortion and higher linearity than competing solutions. The THS770006 was designed with a voltage-mode output to improve gain flatness in the pass band and eliminate the need for output inductors, thereby lowering BOM costs.

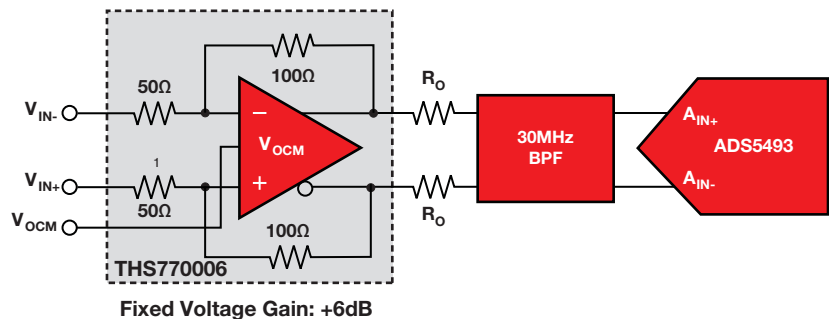

THS770006 functional block diagram

Wideband, Unity-Gain Stable, JFET-Input Operational Amplifier

OPA659

Get samples, datasheets and EVMs at: www.ti.com/sc/device/OPA659

Key Features

- High bandwidth: 650MHz ($G = +1\text{V}/\text{V}$)
- High slew rate: 2550V/ms (4V step)
- Excellent THD: -78dBc at 10MHz
- Low input voltage noise: $8.9\text{ nV}/\sqrt{\text{Hz}}$
- Fast overdrive recovery: 8ns
- Fast settling time: (1% 4V step): 8ns
- Low input offset voltage: $\pm 1\text{ mV}$
- Low input bias current: $\pm 10\text{ pA}$
- High output current: 70mA

Applications

- High-impedance data acquisition input amplifier
- High-impedance oscilloscope input amplifier
- Wideband photodiode transimpedance amplifier
- Wafer scanning equipment

The OPA659 combines a very wideband, unity-gain stable, voltage-feedback operational amplifier with a JFET-input stage to offer an ultra-high dynamic range amplifier for high impedance buffering in data acquisition applications, such as oscilloscope front-end amplifiers, and machine vision applications, such as photodiode transimpedance amplifiers used in wafer inspection.

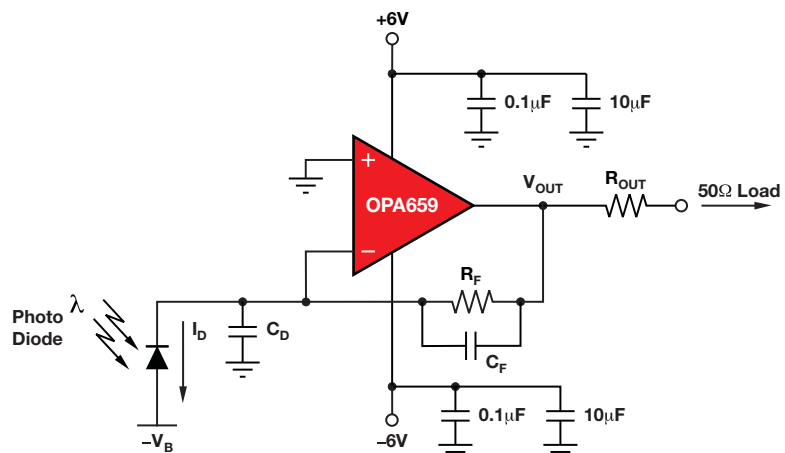

OPA659 functional block diagram

Amplifiers and Comparators

→ High-Speed Amplifiers (>50MHz)

High-Speed Amplifiers

Device	Ch.	SHDN	Supply Voltage (V)	A _{CL} (min)	BW at A _{CL} (MHz) (typ)	BW G = +2 (MHz) (typ)	GBW Product (MHz) (typ)	Slew Rate (V/μs)	Settling Time 0.10% (ns) (typ)	Distortion 1VPP, G = 2 5MHz		V _N (nV/√Hz) (typ)	V _{OS} (mV) (max)	I _B (μA) (max)	I _Q Per Ch. (mA) (typ)	I _{OUT} (mA) (typ)	HiRel Avail.	Package(s)	Price*
										HD ₂ (dBc) (typ)	HD ₃ (dBc) (typ)								
Voltage Feedback (Sorted by Ascending Gain Bandwidth Product)																			
THS4051/52	1, 2	N	±5, ±15	1	70	38	—	240	60	-72, G=2	-90, G=2	14	10	6	8.5	100	Y	SOIC, MSOP PowerPAD™	0.95
THS4281	1	N	+2.7, ±5, +15	1	90	40	—	35	78	-69, 1MHz	-76, 1MHz	12.5	30	0.5	750	30	N	SOT23-5, MSOP, SOIC	0.95
OPA2889	2	Y	5, ±5	1	115	60	75, G > 20	250	25	-80	-82	8.4	5	0.75	0.46	40	N	MSOP, SOIC	1.20
THS4011/12	1, 2	N	±5, ±15	1	290	50	—	310	37	-84, G=2	-96, G=2	7.5	6	6	7.8	110	Y	SOIC, MSOP PowerPAD	1.85
THS4081/82	1, 2	N	±5, ±15	1	175	70	—	230	43	-63, G=2	-73, G=2	10	7	6	3.4	85	N	SOIC, MSOP PowerPAD	1.20
OPAy354/57	1, 2, 4	Y	2.5 to 5.5	1	250	90	100, G = 10	150	30	-75, 1MHz, 2Vpp	-83, 1MHz, 2Vpp	6.5	8	50pA	4.9	100	Y	SOT23, SOIC PowerPAD	0.70
OPAy890	1, 2	Y	5, ±5	1	275	92	130, G > 20	400	10	-102	-94	8	6	1.6	2.25	40	N	MSOP, SOIC	0.75
OPAy830	1, 2, 4	N	+3, +5, ±5	1	310	120	110, G ≥ 10	600	42	-71	-77	9.5	1.5	10	4.25	150	N	SOT23, SOIC	0.50
THS4221/22	1, 2	N	3, 5, ±5, 15	1	230	100	120, G > 10	975	25	-90	-100	13	10	3	14	100	N	SOIC, MSOP PowerPAD	.95
OPA2613	2	N	5, ±6	1	230	110	125, G ≥ 20	70	40	-95	-97	1.8	1	10	6	350	N	SOIC, SOIC PowerPAD	1.55
OPAy300/301	1	Y	2.7 to 5.5	1	400	80	150	80	30	-74, 1MHz, G = 2	-79, 1MHz, G = 2	3	5	0.5	12	40	N	SOT23, SOIC	0.75
OPA842	1	N	±5	1	350	150	200	400	15	-94	-93	2.6	1.2	35	20.2	100	N	SOT23, SOIC	1.55
OPA2652	2	N	±5	1	700	200	200, G ≥ 10	335	—	-76	-66	8	7	15	5.5	140	N	SOT23, SOIC	1.15
OPAy356	1, 2	N	2.5 to 5.5	1	450	100	200, G = 1	300	30	-81, 1MHz, G = 2	-93, 1MHz, G = 2	5.8	9	50pA	8.3	60	Y	SOT23, SOIC, MSOP	0.70
OPAy355	1, 2, 3	Y	2.5 to 5.5	1	450	100	200, G ≥ 10	300	30	-81, 1MHz, G = 2	-93, 1MHz, G = 2	5.8	9	50pA	8.3	60	N	SOT23, SOIC, MSOP, TSSOP	0.70
THS4631	1	N	±15	1	325	105	210, G > 20	1000	40	-76	-94	7	0.26	100pA	11.5	98	N	SOIC, SOIC, MSOP PowerPAD	3.55
THS4031/32	1, 2	N	±5, ±15	1	275	100	220	100	60	-81, THD	—	1.6	2	6	8.5	90	Y	SOIC, MSOP PowerPAD	1.80
OPA2822	2	N	5, ±5	1	400	200	240, G ≥ 20	170	32	-95	-105	2	1.2	12	4.8	150	N	SOIC, MSOP	1.35
OPA656	1	N	±5	1	400	185	230, G > 10	290	8	-74	-100	6	2	20pA	25	60	N	SOT23, SOIC	3.65
OPA698	1	N	5, ±5	1	450	215	250, G ≥ 5	1100	—	-74, 2Vpp	-87, 2Vpp	5.6	5	10	15.5	120	Y	SOIC	1.90
OPAy820	1, 4	N	5 to ±5	1	800	240	280, G ≥ 20	240	18	-90	-110	2.5	0.75	17	5.6	110	N	SOIC, SOIC PowerPAD	0.90
OPA2614	2	N	5, ±6	2	180	180	290, G ≥ 20	145	35	-92, 1MHz	-110, 1MHz	1.8	1	14.5	6.5	350	N	SOIC, SOIC PowerPAD	1.95
OPAy690	1, 2, 3	Y	5, ±5	1	500	220	300, G > 10	1800	8	-77	-81	5.5	4	8	5.5	190	N	SOT23, SOIC, SSOP	1.35
THS4271/75	1	Y	5, ±5, 15	1	1400	390	400, G > 10	1000	25	-70, 30MHz	-90	3	10	15	22	160	Y	SOIC, MSOP PowerPAD	2.25
OPA843	1	N	±5	3	500	—	800, G = 5	1000	7.5	-96, G = 5	-110, G = 5	2	1.2	35	20.2	100	N	SOT23, SOIC	1.60
THS4304	1	N	3 to ±5	1	3000	1000	870, G > 10	1000	5	-100	-100	2.4	4	6	18	100	Y	SOT23, SOIC, MSOP	2.20
OPA699	1	N	5, ±5	4	260	—	1000, G = 6	1400	7	-67, 2Vpp	-87, 2Vpp	4.1	5	10	15.5	120	Y	SOIC	1.95
OPA657	1	N	±5	7	350	—	1600, G > 40	700	10	-74, G = 10	-106, G = 10	4.8	1.8	20pA	14	70	N	SOT23, SOIC	4.10
OPAy846	1, 2	N	±5	7	500	—	1750, G ≥ 40	625	10	-100, G = 10	-112, G = 10	1.2	0.6	19	12.6	80	N	SOT23, SOIC	1.70
OPA847	1	Y	±5	12	600	—	3800, G ≥ 50	950	10	-105, G = 20	-105, G = 20	0.85	0.5	39	18.1	75	N	SOT23, SOIC	2.00
Current Feedback (Sorted by Ascending Gain of +2 Bandwidth)																			
THS3110/11	1	Y	±5, ±15	1	100	90	—	1300	27	-53, 10MHz, ±15V	-62, 10MHz, ±15V	3	6	20	4.8	260	N	SOIC, MSOP PowerPAD	1.25
THS3112/15	2	Y	±5, ±15	1	110	110	—	1550	63	-70, ±15V	-61, ±15V	2.2	8	23	4.9	270	N	SOIC, SOIC PowerPAD	2.50
THS3120/1	1	Y	±5, ±15	1	130	120	—	1500	11	-53, ±15V	-65, ±15V	2.5	6	3	7	475	N	SOIC, MSOP PowerPAD	1.85
THS3122/25	2	Y	±5, ±15	1	160	128	—	1550	64	-69, ±15V	-70, ±15V	2.2	6	23	8.4	440	N	SOIC, SOIC PowerPAD	3.70
OPAy683	1, 2	Y	5, ±5	1	200	150	—	540	—	-65, R _L = 1k	-74, R _L = 1k	4.4	3.5	4	0.94	110	N	SOT23, SOIC	1.20
OPAy684	1, 2, 3, 4	Y	5, ±5	1	210	160	—	820	—	-66, R _L = 1k	-89, R _L = 1k	3.7	3.5	35	1.7	120	N	SOT23, SOIC, TSSOP	1.35
OPA2677	2	N	5, ±6	1	220	200	—	2000	—	-82, G = 4	-93, G = 4	2	4.54	30	9	500	N	SOIC, SOIC PowerPAD, QFN	1.50
THS3091/5	1	Y	±5, ±15	1	235	210	—	5000	42	-77, ±15V R _L = 1kΩ	-69, ±15V R _L = 1kΩ	2	3	15	9.5	280	N	SOIC, SOIC PowerPAD	2.65
THS3092/6	2	Y	±5, ±15	1	235	210	—	5000	42	-66, ±15V R _L = 1kΩ	-78, ±15V R _L = 1kΩ	2	4	15	9.5	280	N	SOIC, SOIC PowerPAD	4.90

*Suggested resale price in U.S. dollars in quantities of 1,000. See www.ti.com/hi-rel for HiRel options.

Amplifiers and Comparators

→ High-Speed Amplifiers (>50MHz)

High-Speed Amplifiers (continued)

Device	Ch.	SHDN	Supply Voltage (V)	A _{CL} (min)	BW at A _{CL} (MHz) (typ)	BW G = +2 (MHz) (typ)	GBW Product (MHz) (typ)	Slew Rate (V/μs)	Settling Time 0.10% (ns) (typ)	Distortion 1V _{PP} , G = 2 5MHz		V _N (nV/√Hz) (typ)	V _{OS} (mV) (max)	I _B (μA) (max)	I _O Per Ch. (mA) (typ)	I _{OUT} (mA) (typ)	HiRel Avail.	Package(s)	Price*
										HD ₂ (dBc) (typ)	HD ₃ (dBc) (typ)								
OPA2674	2	Y	5, ±6	1	250	225	—	2000	—	-82, G = 4	-93, G = 4	2	4.5	30	9	500	N	SOIC, SOIC PowerPAD™	1.75
OPAy691	1, 2, 3	Y	5, ±5	1	280	225	—	2100	8	-79	-93	1.7	2.5	35	5.1	190	N	SOT-23, SOIC, SSOP	1.45
OPA2673	2	Y	±6	1	300	300	—	2800	—	-68, 20MHz, G = 4	-72, 20MHz, G = 4	1.9	TBD	10	28	700	N	QFN, MSOP PowerPAD	1.65
OPAy694	1, 2	N	±5	1	1500	690	—	1700	13	-92	-93	2.1	4.1	18	5.8	80	N	SOT-23, SOIC	1.25
OPAy695	1, 2, 3	Y	5, ±5	1	1700	1400	—	4300	—	-78, G = 8	-86, G = 8	1.8	3	30	12.9	120	N	SOT23, SOIC	1.35
Fully Differential Amplifiers (Sorted by Ascending Gain Bandwidth Product)																			
THS4521/2/4	1, 2, 4	Y	2.5, 5.5	1	145	50	95	490	13	-133, 10KHz	-140, 10KHz	4.6	3.5	0.9	1.14	55	N	SOIC, MSOP, TSSOP	1.10
THS4130/31	1	Y	5, ±5, ±15	1	150	90	180	52	78	-72, G = 1, ±15V	-53, G = 1, ±15V	1.3	2	6	12.3	85	N	SOIC, MSOP PowerPAD	2.80
THS4502/03	1	Y	5, ±5	1	370	175	300, G > 10	2800	6.3	-83, 8MHz, G = 1	-97, 8MHz, G = 1	6	7	4.6	23	120	N	SOIC, MSOP PowerPAD	4.00
THS4520	1	Y	3 to 5	1	600	400	1200	520	7	-101, 1MHz, G = 1	-101, 1MHz, G = 1	2	25	11	13	105	N	QFN	1.65
THS4511	1	Y	3, 5	1	1600	1400	2000	4900	3.3	-117, 10MHz	-106, 10MHz	2	5.2	15.5	39.2	61	Y	QFN	4.35
THS4513	1	Y	3, 5	1	1600	1400	2800	5100	16	-110, 10MHz	-108, 10MHz	2.2	5.2	13	37.7	96	Y	QFN	4.10
THS4508	1	Y	3, 5	2	2000	2000	3000	6400	2	-104, 10MHz	-105, 10MHz	2.3	5	15.5	39.2	61	N	QFN	4.95
THS4509	1	Y	3, 5	2	2000	2000	3000	6600	2	-104, 10MHz	-109, 10MHz	1.9	5	13	37.7	96	Y	QFN	3.75
PGA870	1	Y	5	—	—	650	—	2900	5	-93, 100MHz	-88, 100MHz	—	35	—	143	50	N	QFN	4.35
THS770006	1	Y	5	—	—	2400	—	3100	2.2	-78, 100MHz	-86, 100MHz	1.7	12.5	100	100	80	N	QFN	4.10
THS770012	1	Y	5	—	900	—	—	3300	2.2	-73, 100MHz	-84, 100MHz	1.5	22.5	100	100	80	N	QFN	4.10
Fixed and Programmable Gain (Sorted by Ascending ACL Bandwidth)																			
THS7001/02	1, 2	Y	±4.6, ±16	2	70	85	—	85	70	-65	-80	1.7	—	8	5.5	70	N	HTSSOP	5.85
OPAy832	1, 2	N	2.8 to ±5	1	90	80	—	350	45	-66	-73	9.2	7	10	4.25	120	N	SOT23, SOIC	0.45
BUF634	1	N	5, ±5, ±15	1	180	—	—	2000	200	—	—	4	100	20	15	250	N	SOIC	3.50
OPAy692	1, 3	Y	5, ±5	1	280	225	—	2000	8	-79	-94	1.7	2.5	35	5.1	190	N	SOT23, SOIC, SSOP	1.15
BUF602	1	N	3.3, 5, ±5	1	1200	—	—	8000	—	-76	-98	5.1	30	7	5.8	60	N	SOT23, SOIC	0.85
OPAy693	1	Y	5, ±5	1	1400	700	—	2500	12	-82, 10MHz	-96, 10MHz	1.8	2	35	13	120	N	SOT23, SOIC	1.60
THS4303	1	Y	3, 5	10	1800	—	18000	5500	—	-75, 70MHz, G = 10	-80, 70MHz, G = 10	2.5	4.25	10	34	180	N	MSOP PowerPAD	2.60
THS4302	1	Y	3, 5	5	2400	—	12000	5500	—	-75, 70MHz, G = 5	-85, 70MHz, G = 5	2.8	4.25	10	37	180	N	MSOP PowerPAD	2.90
PGA870	1	Y	5	—	—	650	—	2900	5	-93, 100MHz	-88, 100MHz	—	35	—	143	50	N	QFN	4.35
THS770006	1	Y	5	—	—	2400	—	3100	2.2	-78, 100MHz	-86, 100MHz	1.7	12.5	100	100	80	N	QFN	4.10
JFET-Input and CMOS Amplifiers																			
OPA358	1	Y	2.7 to 3.3	1	100	10	80	55	35	—	—	6.4	6	50pA	7.5	50	N	SC70	0.45
OPAy380	1, 2	N	2.7 to 5.5	1	100	10	90	80	—	—	—	67	0.025	50pA	7.5	50	N	MSOP, SOIC	1.95
OPAy354	1, 2, 4	N	2.5 to 5.5	1	250	90	100, G = 10	150	30	-75, 1MHz	-83, 1MHz	6.5	8	50pA	4.9	100	Y	SOT23, SOIC PowerPAD	0.70
OPAy357	1, 2	Y	2.5 to 5.5	1	250	90	100, G = 10	150	30	-75, 1MHz	-83, 1MHz	6.5	8	50pA	4.9	100	N	SOT23, SOIC PowerPAD	0.70
OPAy300/301	1, 2	Y	2.7 to 5.5	1	—	80	150	80	30	-72, 1MHz	-79, 1MHz	3	5	5pA	12	40	N	SOT-23, SOIC	0.75
OPAy355	1, 2, 3	Y	2.5 to 5.5	1	450	100	200, G = 10	300	30	-81, 1MHz	-93, 1MHz	5.8	9	50pA	8.3	60	N	MSOP	0.70
OPAy356	1, 2	N	2.5 to 5.5	1	450	100	200, G = 10	300	30	-81, 1MHz	-93, 1MHz	5.8	9	50pA	8.3	60	Y	SOT23, SOIC	0.70
THS4631	1	N	±15	1	325	105	210, G > 20	1000	40	-76	-94	7	0.26	100pA	11.5	98	N	SOIC, SOIC & MSOP PowerPAD	3.55
OPA653	1	N	7 to 13	2	500	500	—	2675	—	-72, 10MHz	-90, 10MHz	6.1	5	50	33.5	70	N	SOT23, SON	2.95
OPA656	1	N	±5	1	400	185	230, G > 10	290	8	-74	-100	6	2	2pA	25	60	N	SOT23, SOIC	3.65
OPA657	1	N	±5	7	350	—	1600, G > 40	700	10	-74, G = 10	-106, G = 10	4.8	1.8	2pA	14	70	N	SOT23, SOIC	4.10
OPA659	1	N	7 to 13	2	650	335	350, G > 20	2550	8	-79, 10MHz	-100, 10MHz	8.9	5	50	33.5	70	N	SOT23, SON	2.95
Transconductance Amplifiers																			
OPA860	1	N	±5	1	470	—	470	3500	—	-77	-79	2.4	—	5	11.2	15	N	SOIC	2.45
OPA861	1	N	±5	1	80	—	400	900	—	-68	-57	2.4	—	1	5.4	15	N	SOT23, SOIC	1.05

*Suggested resale price in U.S. dollars in quantities of 1,000. See www.ti.com/hi-rel for HiRel options.

New products are listed in bold red.

Amplifiers and Comparators

→ High-Speed Amplifiers (>50MHz)

High-Speed Amplifiers (continued)

Device	Ch.	SHDN	Supply Voltage (V)	A _{CL} (min)	BW at A _{CL} (MHz) (typ)	BW G = +2 (MHz) (typ)	GBW Product (MHz) (typ)	Slew Rate (V/μs)	Settling Time 0.10% (ns) (typ)	Distortion 1V _{PP} , G = 2 5MHz		V _{NI} (nV/√Hz) (typ)	V _{OS} (mV) (max)	I _B (μA) (max)	I _O Per Ch. (mA) (typ)	I _{OUT} (mA) (typ)	HiRel Avail.	Package(s)	Price*
										HD ₂ (dBc) (typ)	HD ₃ (dBc) (typ)								
Transimpedance Amplifiers (Sorted by Ascending Gain Bandwidth Product)																			
OPAy380	1, 2	N	2.7, 5.0	1	90	45	90	80	2000	—	—	5.8	0.025	50pA	6.5	50	N	MSOP, SOIC	1.95
THS4631	1	N	±15	1	325	105	210, G > 20	1000	40	-76	-94	7	0.26	100pA	11.5	98	N	SOIC, SOIC and MSOP PowerPAD	3.55
OPA656	1	N	±5	1	400	185	230, G > 10	290	8	-74	-100	6	2	20pA	25	60	N	SOT23, SOIC	3.65
OPA657	1	N	±5	7	350	—	1600, G > 40	700	10	-74, G = 10	-106, G = 10	4.8	1.8	20pA	14	70	N	SOT23, SOIC	4.10
OPAy846	1, 2	N	±5	7	500	—	1750, G ≥ 40	625	10	-100, G = 10	-112, G = 10	1.2	0.6	19	12.6	80	N	SOT23, SOIC	1.70
OPA847	1	Y	±5	12	600	—	3800, G ≥ 50	950	10	-105, G = 20	-105, G = 20	0.85	0.5	39	18.1	75	N	SOT23, SOIC	2.00
Multiplexers																			
MPA4609	4	N	5	190	90	—	—	150	—	—	—	0.65	0.2	—	12.5	—	N	TQFP	4.95
OPAy875	1, 3	Y	±3 to ±6	2	700	700	—	3100	3	-71	-90	6.7	7	±18	11	±70	N	MSOP, SOIC	1.45
OPA4872	1	Y	±3.5 to ±6	1	1100	500	—	2300	14	-60, 10MHz	-78, 10MHz	4.5	5	18	10.6	±75	Y	SOIC	2.15
Voltage-Limiting Amplifiers																			
OPA698	1	N	5, ±5	1	450	215	250	1100	—	-82	-88	5.6	5	10	15.5	120	Y	SOIC	1.90
OPA699	1	N	5, ±5	4	260	—	1000	1400	—	—	—	4.1	5	10	15.5	120	Y	SOIC	1.95
RF/IF Amplifiers																			
THS9000/1	1	N	3, 5	5.8	500	—	—	—	—	—	—	0.6	—	—	Var	—	N	MicroMLP, SOT23	1.05
DC Restoration (Sample/Hold Amplifier)																			
OPA615	1	N	±5	1	710	—	—	2500	—	-62	-47	4.6	4	1	13	5	N	SOIC, MSOP	4.55

Video Amplifiers (Sorted by Ascending G = +2 Bandwidth)

Device	Description	Ch.	SHDN	Supply Voltage (V)	-3dB at G = +2 Bandwidth (MHz)	0.1dB Gain Flatness (MHz)	Diff Gain (%)	Diff Phase (°)	Slew Rate (V/μs)	Offset Voltage (mV) (max)	I _O Per Ch. (mA) (typ)	Input Range (V)	RR0	HiRel Avail.	Package(s)	Price*
THS7313	I ² C, SD 5th-Order LPF	3	Y	2.7 to 5.5	8	4	0.07	0.12	35	35	6	0 to 2.4	Y	N	TSSOP-20	1.20
THS7314	SDTV, 5th-Order Butterworth	3	Y	2.85 to 5.5	8.5	4.2	0.1	0.1	36	390	5.3	0 to 2.4	Y	N	SOIC	0.40
THS7315	SDTV, 5th-Order Butterworth, 5.2V/V Gain	3	N	2.85 to 5.5	8.5	—	0.2	0.3	37	420	5.2	0 to 0.56	Y	N	SOIC	0.50
THS7374	SDTV, 6th-Order Butterworth, 6dB Gain	4	Y	2.85 to 5	9.5	—	0.5	0.5	150	380	4	-0.1 to 1.46	Y	N	TSSOP-14	0.55
THS7375	SDTV, 6th-Order Butterworth, 5.6V/V Gain	4	Y	2.85 to 5.5	9.5	—	0.5	0.5	150	365	4	-0.1 to 0.9	Y	N	TSSOP-14	0.55
OPA360	G = 2, DC-Coupled, LPF, Use with DM270/275/320	1	Y	2.7 to 3.3	9MHz 2-Pole Filter	5	0.5	1	55	80	6	GND to (V+)-1.5	Y	N	SC-70	0.35
OPA361	G = 5.2, DC-Coupled, LPF, TV with Detect	1	Y	2.5 to 3.3	9MHz 2-Pole Filter	5	0.5	1	55	55	5.3	GND to 0.55	Y	N	SC-70	0.35
THS7318	EDTV/SDTV	3	Y	2.85 to 5	20	11	0.05	0.03	80	200	3.5	0 to 2.4	Y	N	Wafer Scale	3.75
THS7316	HDTV, 5th-Order	3	N	2.85 to 5.5	36	—	0.1	0.1	—	390	5.8	0 to 2.3	Y	N	SOIC	0.55
THS4281	Low Power, High Speed, RRIO	1	N	+2.7, ±5, +15	40	20	0.05	0.08	35	12.5	750	30	Y	N	SOT, MSOP	0.95
OPA358	Small Package, Low Cost	1	Y	2.7 to 3.3	40	12	0.3	0.7	55	6	5.2	GND -0.1 to (V+)-1	Y	N	SC-70	0.45
OPAy832	VFB, Fixed Gain	1, 2, 3	N	+2.8, ±5	80	—	0.1	0.16	350	7	4.25	-0.5 to 1.5	Y	N	SOT-23, SOIC	0.70
OPAy354	VFB, Low Cost	1, 2, 4	N	2.5 to 5.5	100	40	0.02	0.09	150	8	4.9	-0.1 to 5.4	Y	Y	SOT-23, SOIC, MSOP, TSSOP	0.70

*Suggested resale price in U.S. dollars in quantities of 1,000. See www.ti.com/hirel for HiRel options.

Amplifiers and Comparators

→ High-Speed Amplifiers (>50MHz)

Video Amplifiers (Sorted by Ascending G = +2 Bandwidth) (continued)

Device	Description	Ch.	SHDN	Supply Voltage (V)	-3dB at G = +2 Bandwidth (MHz)	0.1dB Gain Flatness (MHz)	Diff Gain (%)	Diff Phase (°)	Slew Rate (V/μs)	Offset Voltage (mV) (max)	I _Q Per Ch. (mA) (typ)	Input Range (V)	RRO	HiRel Avail.	Package(s)	Price*
OPAy357	VFB, Low Cost, SHDN	1, 2	Y	2.5 to 5.5	100	40	0.02	0.09	150	8	4.9	-0.1 to 5.4	Y	N	SOT-23, SOIC, MSOP	0.70
OPAy830	Voltage Feedback	1, 2, 4	N	+2.8, ±5.5	110	—	0.07	0.17	600	7	4.25	-0.45 to 1.2	Y	N	SO-8, SOT-23	0.50
OPA842	Voltage Feedback	1	N	±5	150	56	0.003	0.008	400	1.2	20.2	±3.2	N	N	SOT-23, SOIC	1.55
OPAy683	Current Feedback	1, 2	Y	±5, +5	150	37	0.06	0.03	540	1.5	0.9	±3.75	N	N	SOT-23, SOIC, MSOP	1.20
THS7353	I ² C, Selectable SD/ED/HD/Bypass, 5th-Order LPF, 0dB Gain	3	Y	2.7 to 5.5	9/16/35/150	5/9/20/25	0.15	0.3	40/70/150/300	20	5.9	0 to 3.4	YN	N	TSSOP-20	1.65
OPAy684	Current Feedback	1, 2, 3, 4	Y	±5, +5	160	19	0.04	0.02	820	3.5	1.7	±3.75	N	N	SOT-23, SOIC	1.35
VCA822	Wideband, Variable Gain, Linear in V/V	1	Y	±5	168	28	—	—	1700	17	36	-2.1 to +1.6	N	N	MSOP, SOIC	2.80
THS7303	I ² C, Selectable SD/ED/HD/Bypass, 5th-Order LPF, 6dB	3	Y	2.7 to 5.5	9/16/35/190	5/9.5/22/125	0.13	0.55	40/75/155/320	35	6	0 to 2.4	Y	N	TSSOP-20	1.65
OPAy355	VFB, Low Cost, SHDN	1, 2, 3	Y	2.5 to 5.5	200	75	0.02	0.05	300	9	8.3	-0.1 to 3	Y	N	SOT-23, SOIC, MSOP, TSSOP	0.70
OPAy356	VFB, Low Cost	1, 2	N	2.5 to 5.5	200	75	0.02	0.05	300	9	8.3	-0.1 to 3	Y	Y	SOT-23, SOIC, MSOP	0.70
OPA656	VFB, JFET Input	1	N	±5	200	30	0.02	0.05	290	1.8	14	-4/+2.5	N	N	SOT-23, SOIC	3.65
OPAy690	Voltage Feedback	1, 2, 3	Y	±5, +5	220	30	0.06	0.03	1800	4	5.5	±3.5	N	N	SOT-23, SOIC	1.35
OPAy691	Current Feedback	1, 2, 3	Y	±5, +5	225	90	0.07	0.02	2100	2.5	5.1	±3.5	N	N	SOT-23, SOIC	1.45
OPAy820	Voltage Feedback	1, 4	N	±5, ±5	230	—	0.01	0.03	240	0.75	5.6	0.9 to 4.5	N	N	SOT-23, SOIC	0.90
OPAy692	CFB1, Fixed Gain	1, 3	Y	±5, +5	240	120	0.07	0.02	2000	2.5	5.1	±3.5	N	N	SOT-23, SOIC	1.15
THS7360	3-SD and 3-SD/ED/HD/Full-HD Filters and High Gain	6	Y	2.7 to 5	9.2/17/35/70/290	8/15/31/61/180	0.15	0.35	850	315	2.5	-0.1 to 2.3	Y	N	TSSOP-20	0.99
THS7364	3-SD and 3-Full-HD Filters and 6-dB Gain	6	Y	2.7 to 5	9.5/72/350	8.2/60/300	0.2	0.35	500	400	2.3	-0.1 to 2.3	Y	N	TSSOP-20	0.80
THS7368	3-SD and 3-SD/ED/HD/Full-HD Filters and 6-dB Gain	6	Y	2.7 to 5	9.5/18/36/72/375	8.2/16/30/60/300	0.2	0.35	600	400	2.3	-0.1 to 2.3	Y	N	TSSOP-20	0.95
THS7327	RGBHV Buffer, I ² C, 2:1MUX	3	Y	2.7 to 5.5	9/16/35/75/500	4/7/15/38/56	0.3	0.45	1300	65	33	0 to 2.4	Y	N	TQFP-48	3.35
THS7347	RGBHV Buffer, I ² C, 2:1MUX	3	Y	2.7 to 5.5	500	350	0.05	0.1	1300	15	26.8	0 to 2.4	Y	N	TQFP-48	2.75
OPAy694	Current Feedback	2	N	±5	690	—	0.03	0.015	1700	4.1	5	±2.5	N	N	SOT-23, SOIC	1.25
OPAy693	CFB, Fixed Gain	1, 3	Y	±5, +5	700	200	0.03	0.01	2500	2	13	±3.4	N	N	SOT-23, SOIC	1.60
VCA824	Ultra-Wideband, Variable Gain, Linear in V/V	1	Y	±5	710	135	—	—	2500	17	36	2.1 to +1.6	N	N	MSOP, SOIC	3.50
OPA695	Current Feedback	1, 2, 3	Y	±5, +5	1400	320	0.04	0.007	4300	3	12.9	±3.3	N	N	SOT-23, SOIC	1.35
BUF602	Closed-Loop Buffer-AV = ±1, 1.4GHz	1	N	±5, 3.3	N/A	240	0.15	0.04	8000	30	5.8	±4.0	N	N	SOT-23, SOIC	0.85
OPA615	DC Restoration	1	N	±5	N/A	N/A	N/A	N/A	2500	N/A	13	±3.5	N	N	SO-14, MSOP	4.55
OPA861	Transconductance	1	N	±5	N/A	N/A	—	—	900	12	5.4	±4.2	N	N	SOT-23, SOIC	1.05
SN10501 SN10502 SN10503	High Speed, Rail-to-Rail	1,2,3	N	3, 5, ±5	230	100	50	0.007	0.007	25	100	±4.0	N	N	SOIC, HTSSOP, MSOP Power-PAD™, 0.85"	0.70 1.20 1.65
Video Multiplexers																
OPA4872	4:1 MUX	1	Y	±3.5, ±6	500	120	0.035	0.005	2300	5	10.6	±2.8	N	Y	SOIC	2.15
OPAy875	2:1 MUX	1, 3	Y	±3, ±6	700	200	0.025	0.025	3100	7	11	±2.8	N	N	MSOP, SOIC, SSOP, QSOP	1.45

*Suggested resale price in U.S. dollars in quantities of 1,000. See www.ti.com/hirel for HiRel options.

New products are listed in bold red.

Amplifiers and Comparators

→ High-Speed Amplifiers (>50MHz)

Voltage-Controlled Amplifiers

Device	V_N (nV/ $\sqrt{\text{Hz}}$)	Bandwidth (MHz) (typ)	Specified at V_S (V)	Number of Channels	Variable Gain Range (dB)	HiRel Available	Package(s)	Price*
VCA8613	1.2	14	3	8	40	N	TQFP-64	25.40
VCA8500	0.8	15	3.3	8	45	N	QFN-64	32.00
VCA8617	1	15	3	8	40	N	TQFP-64	24.00
VCA810	2.4	30	± 5	1	80	N	SO-8	6.15
VCA2618	5.4	30	5	2	43	N	TQFP-32	9.25
VCA2612	1.25	40	5	2	45	N	TQFP-48	12.50
VCA2613	1	40	5	2	45	N	TQFP-48	10.25
VCA2614	4.8	40	5	2	40	N	TQFP-32	8.35
VCA2616/2611	0.95	40	5	2	40	N	TQFP-48	10.25
VCA2619	5.9	40	5	2	50	N	TQFP-32	8.40
VCA2615	0.7	42	5	2	52	N	QFN-48	8.05
VCA2617	3.8	50	5	2	48	N	QFN-32	7.95
VCA820	6	150	± 5	1	40	N	MSOP-10, SO-14	2.80
VCA822	6	150	± 5	1	40V/V	N	MSOP-10, SO-14	2.80
THS7530	1.27	300	5	1	46	N	HTSSOP-14	3.95
VCA821	8.2	420	± 5	1	40	N	MSOP-10, SO-14	3.50
VCA824	8.2	420	± 5	1	40V/V	N	MSOP-10, SO-14	3.50

Line Drivers

Device	Description	BW Gain = 1 (MHz)	BW Gain = +2 (MHz)	Slew Rate (V/ μ s)	V_N $f > 1\text{MHz}$ (nV/ $\sqrt{\text{Hz}}$)	V_{OUT} Swing (R_{LOAD0}) (min) (V)	Power Supply Range (V)	I_Q / Amplifier (mA) (max)	I_{OUT} (mA) (min)	Disable/ Power Control	HiRel Avail.	Package(s)	Price*
THS6204	Dual-Port, Differential VDSL2 Line Driver	—	114	3800	2.5	± 10.9 (100)	± 5 to ± 14	21.5/port	± 416	Y	N	QFN, HTSSOP	1.40
THS6214	Dual Port, Differential VDSL2 Line Driver	—	114	3800	2.7	± 10.9 (100)	± 5 to ± 14	21/port	± 416	Y	N	QFN, HTSSOP	1.40
OPA2691	Dual, Wideband, CFB Amp with Disable	280	225	2100	1.7	± 3.7 (100)	+5 to ± 6.0	5.3	± 190	Y	N	SOIC	2.30
OPA2690	Dual, Wideband, VFB Amp with Disable	500	220	1800	5.5	± 3.7 (100)	+5 to ± 6.0	5.8	± 190	Y	N	SOIC	2.15
THS6093	ADSL CPE Line Driver with Shutdown	90	—	400	2.1	1.3 to 3.7 (100)	± 2.25 to ± 7	9.5	± 240	Y	N	SOIC, HTSSOP	2.15
THS6092	ADSL CPE Line Driver	90	—	400	2.1	1.3 to 3.7 (100)	± 2.25 to ± 7	12	± 240	N	N	SOIC, SOIC PowerPAD™	2.15
THS6042	ADSL CPE Line Driver	120	95	600	2.2	± 4.1 (25)	± 5 to ± 15	9.5	± 300	N	N	SOIC, SOIC PowerPAD	4.10
THS6043	ADSL CPE Line Driver with Shutdown	120	95	600	2.2	± 4.1 (25)	± 5 to ± 15	9.5	± 300	Y	N	SOIC, HTSSOP	3.60
OPA2614	Dual, High I/O with Current Limit	—	180	145	1.8	± 4.9 (100)	+5 to ± 6.3	6	± 350	N	N	SOIC, SOIC PowerPAD	1.95
OPA2613	Dual, High I/O with Current Limit	230	110	70	1.8	± 4.7 (50)	+5 to ± 6.3	6	± 350	N	N	SOIC, SOIC PowerPAD	1.55
OPA2670	VDSL2 Line Driver with Power Control	—	420 ($G=\pm 5$)	5000	3.6	± 4.8 (50)	+5.5 to 12.6	15.75	± 500	Y	N	QFN	1.25
OPA2677	Dual, Wideband, High I/O	220	200	2000	2	± 5.0 (100)	+5 to ± 6.3	12	± 380	N	N	SOIC, SOIC PowerPAD, QFN	1.50
OPA2674	Dual Wideband, High I/O with Current Limit	250	225	2000	2	± 5.0 (100)	+5 to ± 6.3	9.3	± 380	Y	N	SOIC	1.75
THS6184	Dual-Port, Low Power Diff. xDSL Line Driver	50	40	340	3	± 4.1 (100)	± 4 to ± 12	4.2	± 400	Y	N	QFN, HTSSOP	3.75
THS6132	High-Efficiency Class-G ADSL Line Driver	80	70	300	3.5	± 9.9 (30)	± 3.0 to ± 16.5	3	± 400	Y	N	SOIC, SOIC PowerPAD, QFN	2.65
THS6182	Low-Power ADSL Line Driver	100	80	450	3.2	3.7 (25)	4 to 16.5	12.5	± 450	Y	N	SOIC, SOIC PowerPAD, QFN	3.70
OPA2673	Dual, High I/O with Active Off Line Control	600	450	3000	2.4	± 4.8 (100)	3.5 to 6.5	19	± 700	Y	N	QFN, MSOP	1.65
OPA4684	Quad Low-Power CFB Amp	250	170	750	3.7	± 3.9 (1000)	+5 to ± 6.0	1.8	-100/+120	N	Y	SOIC, TSSOP	3.30
OPA2683	Dual Very Low Power CFB Amp	200	150	400	4.4	± 4.1 (1000)	+5 to ± 6.0	2.06	-100/+120	Y	N	SOIC, MSOP, SOT-23-8	1.85
OPA2684	Dual Low-Power CFB Amp	250	170	750	3.7	± 3.9 (1000)	+5 to ± 6.0	1.8	-100/+130	N	N	SOIC, SOT-23-8	2.10

*Suggested resale price in U.S. dollars in quantities of 1,000. See www.ti.com/hirel for HiRel options.

New products are listed in bold red.

→ Audio Amplifiers

0.65-Ω Dual SPDT Analog Switches with Negative Signaling Capability

TS5A22362, TS5A22364

Get samples and datasheets at: www.ti.com/sc/device/TS5A22362 and www.ti.com/sc/device/TS5A22364

Key Features

- Specified break-before-make switching
- Negative signaling capability: maximum swing from -2.75V to 2.75V ($V+ = 2.75\text{V}$)
- Internal shunt switch prevents audible click-and-pop when switching between two sources (TS5A22364)
- Low ON-state resistance (0.65Ω typ)
- Low charge injection
- Excellent ON-state resistance matching
- 2.3V to 5.5V power supply ($V+$)
- Latch-up performance exceeds 100mA

Applications

- Cell phones
- PDAs
- Portable instrumentation
- Audio routing

The TS5A22362 and TS5A22364 are single-pole double-throw (SPDT) analog switches designed to operate from 2.3V to 5.5V. The devices feature negative signal capability that allows signals below ground to pass through the switch without distortion. Additionally, the TS5A22364 includes an internal shunt switch, which automatically discharges any capacitance at the NC or NO terminals when they are unconnected to COM. This reduces the audible click/pop noise when switching between two sources. The break-before-make feature prevents signal distortion during the transferring of a signal from one path to another. Low ON-state resistance, excellent channel-to-channel ON-state resistance matching and minimal total harmonic distortion (THD) performance are ideal for audio applications.

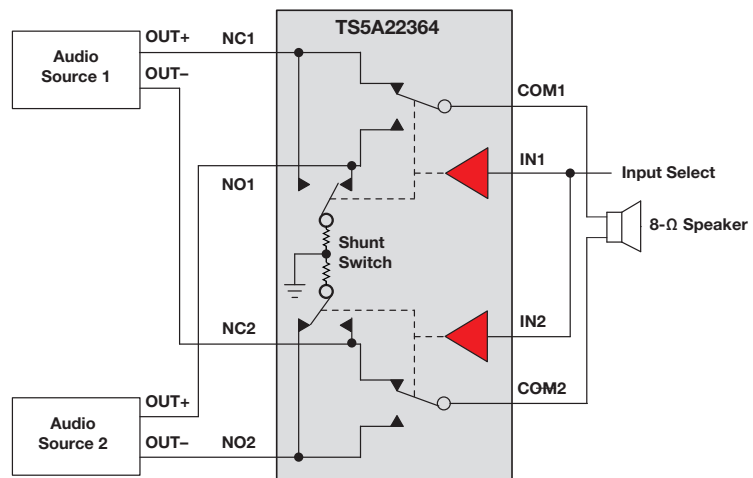

TS5A22364 application block diagram

→ Audio Amplifiers

2W Class-D Audio Amplifier with Adaptive Boost and Battery Tracking SpeakerGuard™ AGC TPA2015D1

Get samples, datasheets and application reports at: www.ti.com/sc/device/TPA2015D1

Key Features

- 2.0W into 8Ω at 3.6V (6% THD) delivering 36% louder audio than the leading competition
- Constant output power of 2.0W (3.6 to 5.0V) resulting in consistent audio loudness across the Li-ion battery
- Battery tracking SpeakerGuard™ that protects speakers by preventing clipping
- Battery tracking AGC that prevents early shutdown at low battery voltages (<3V)
- 2mm x 2mm, 0.5mm pitch 16-ball WCSP with 20% smaller package size than the competition
- High efficiency (81%) (at 1W and 3.6V) resulting in 34% longer battery life

Applications

- Cell phones
- PDAs
- PNDs
- Portable electronics

The TPA2015D1 is a 2.0W filter-free mono Class-D Audio power amplifier with integrated boost converter and battery tracking SpeakerGuard™ AGC technology that:

- Produces consistent audio loudness regardless of battery voltage by delivering constant output power over the Li-ion battery voltage
- Prevents early shutdown by limiting current at low battery voltages
- Protects speakers by preventing clipping of the audio output
- Offers a cheaper and higher performing successor to the boosted class-D product portfolio

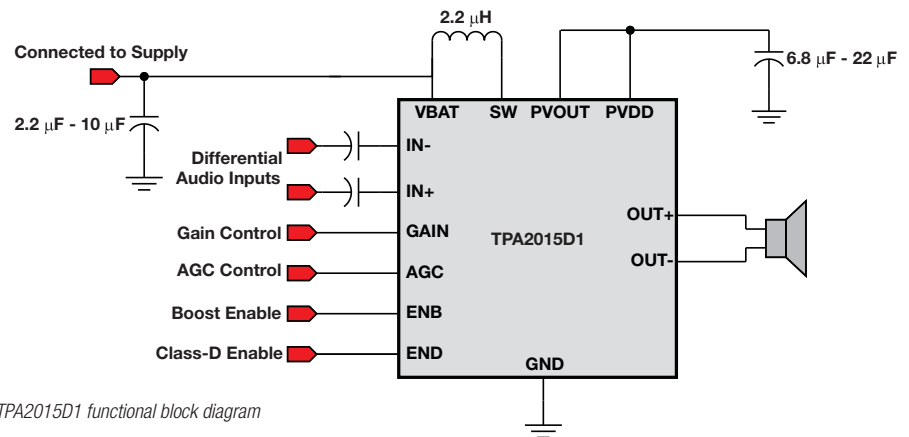

TPA2015D1 functional block diagram

300W Stereo (600W Total) Class-D Amplifier with Integrated Closed-Loop Feedback TAS5630/TAS5631

Get samples, datasheets and application reports at: www.ti.com/sc/device/TAS5630, www.ti.com/sc/device/TAS5631

Key Features

- Integrated closed-loop architecture
- PWM or analog input devices to provide design flexibility
- Flat THD at all frequencies and through to clipping
- Signal bandwidth up to 80kHz for high-frequency content from HD sources
- Ultra-low 0.03% THD at 1W into 4Ω

Applications

- Home theater
- Active speakers
- Mini combo systems
- AV receivers
- DVD receivers

The TAS5630/31 is a high-performance analog/PWM-input Class-D amplifier with integrated closed-loop feedback technology that drives up to 600W total power. Closed-loop architecture provides higher PSRR, which will not only provide better sound quality but reduce power supply requirements, allowing for improved system performance and cost. The efficiency of this class-D amplifier is greater than 88% while still providing ultra-low THD performance. The self-protection design integrates undervoltage protection, overtemperature, clipping, short-circuit and overcurrent protection to safeguard the device and speakers against fault conditions that could damage the system.

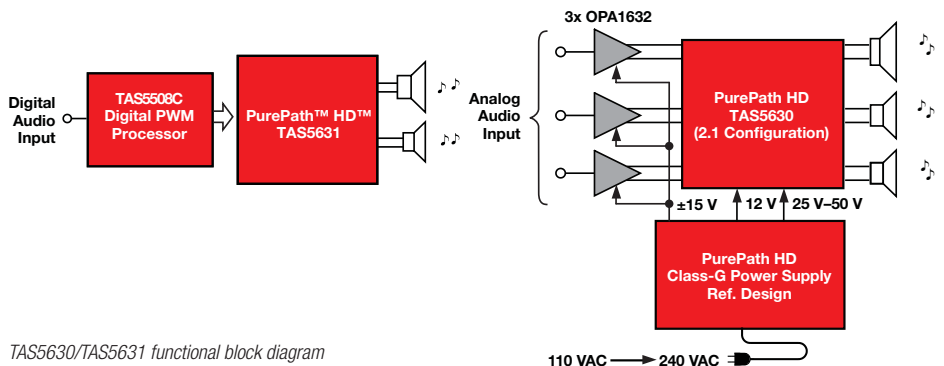

TAS5630/TAS5631 functional block diagram

Amplifiers and Comparators

→ Audio Amplifiers

Family of High Performance Audio Operational Amplifiers

OPA16xx

Get samples, datasheets and app reports at: www.ti.com/sc/device/PARTnumber (Replace **PARTnumber** with **OPA1611**, **OPA1612**, **OPA1641**, **OPA1642**, or **OPA1644**)

OPA1611/12: Bipolar-Input Audio Op Amps

Key Features

- Ultra-low noise: $1.1\text{nV}/\sqrt{\text{Hz}}$ at 1kHz
- Ultra-low distortion: 0.000015% at 1kHz
- High slew rate: $27\text{V}/\mu\text{s}$
- Wide bandwidth: 40MHz ($G = +1$)
- High open loop gain: 130dB
- Unity gain stable
- Low I_Q : 3.6mA per channel
- Rail-to-rail output
- Wide supply range: $\pm 2.25\text{V}$ to $\pm 18\text{V}$
- Single and dual versions available in SO-8 packages

Applications - OPA16xx

- Professional audio equipment
- Microphone Preamplifiers
- Analog and digital mixing consoles
- Broadcast studio equipment
- Audio test and measurement
- High-end A/V receivers
- High-end Blu-ray™ players

OPA1602/04: Bipolar-Input Audio Op Amps

PREVIEW*

Key Features

- Ultra-low noise: $2.5\text{nV}/\sqrt{\text{Hz}}$ at 1kHz
- Ultra-low distortion: 0.00003% at 1kHz
- High slew rate: $20\text{V}/\mu\text{s}$
- Wide bandwidth: 35MHz ($G = +1$)
- High open loop gain: 120dB
- Unity gain stable
- Low I_Q : 2.6mA per channel
- Rail-to-rail output
- Wide supply range: $\pm 2.25\text{V}$ to $\pm 18\text{V}$
- Dual version available in SO-8 and MSOP-8 packages
- Quad version available in SO-14 and TSSOP-14 packages

OPA1641/42/44: FET-Input Audio Op Amps

Key Features

- Ultra-low noise: $5.1\text{nV}/\sqrt{\text{Hz}}$ at 1kHz
- Ultra-low distortion: 0.00005% at 1kHz
- High slew rate: $20\text{V}/\mu\text{s}$
- Low input bias current: 15pA
- High open loop gain: 130dB
- Unity gain stable
- Low I_Q : 1.8mA per channel
- Rail-to-rail output
- Wide supply range: $\pm 2.25\text{V}$ to $\pm 18\text{V}$
- Single and dual versions available in SO-8 and MSOP-8 packages
- Quad version available in SO-14 and TSSOP-14 packages

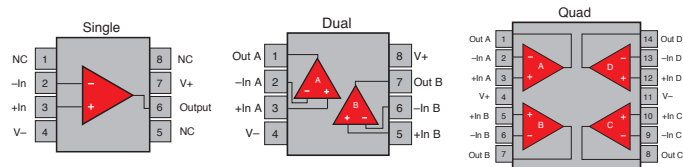

OPA1611/1602/1641 pin configurations

*Expected release date: Q2 2011

Audio Amplifiers – Portable

Device	Description	Amp Class	Amplifier Input Type	Amplifier Output Type	Open/Closed Loop	Speaker Output Power (W)	Headphone Output Power (W)	Load Impedance (Ω)	Supply (V)	Half Power THD+N at 1kHz (%)	Headphone psRR (dB)	Speaker psRR (dB)	HiRel Avail.	Package(s)	Price*
Headphone Amplifiers															
TPA6132A2	25mW DirectPath™ Stereo Headphone Amplifier with Pop Suppression (TPA6132)	Class-AB	Analog	Stereo	Closed	—	0.025	16	2.3 to 5.5	0.025	100	—	N	WQFN-16	0.55
TPA6140A2	25mW Class-G DirectPath Stereo Headphone Amp with I ² C Volume Control (TPA6140)	Class-G	Analog	Stereo	Closed	—	0.025	16	2.5 to 5.5	0.0025	105	—	N	DSBGA-16	0.95
TPA6141A2	25mW Class-G DirectPath Stereo Headphone Amp (TPA6141)	Class-G	Analog	Stereo	Closed	—	0.025	16	2.5 to 5.5	0.0025	105	—	N	DSBGA-16	0.85
Speaker Amplifiers – Portable															
TPA6012A4	3W Stereo Audio Power Amp with Advanced DC Volume Control	Class-AB	Analog	Stereo	Closed	3	—	3	4.5 to 5.5	0.06	—	70	N	HTSSOP-24	1.35
TPA6013A4	3W Stereo Audio Power Amplifier with Advanced DC Volume Control and 2.1 Input Stereo Input Mux	Class-AB	Analog	Stereo	Closed	3	—	3	4.5 to 5.5	0.06	—	70	N	HTSSOP-24	1.45
TPA6017A2	Stereo, Cost-Effective, Class-AB Audio Amplifier	Class-AB	Analog	Stereo	Closed	2	—	3	4.5 to 5.5	0.1	—	77	N	HTSSOP-20	0.65

*Suggested resale price in U.S. dollars in quantities of 1,000.

Amplifiers and Comparators

→ Audio Amplifiers

Audio Amplifiers – Portable (continued)

Device	Description	Amplifier Class	Amplifier Input Type	Amplifier Output Type	Open/Closed Loop	Speaker Output Power (W)	Headphone Output Power (W)	Load Impedance (Ω)	Supply (V)	Half Power THD+N at 1kHz (%)	Headphone psRR (dB)	Speaker psRR (dB)	HiRel Avail.	Package(s)	Price*
Speaker Amplifiers – Portable (continued)															
TPA6211A1	3.1W Mono, Fully Differential, Class-AB Audio Amplifier	Class-AB	Analog	Mono	Closed	3.1	—	3	2.5 to 5.5	0.02	—	85	N	MSOP-8 PowerPAD™, SON-8	0.65
TPA2010D1	2.5W Mono Class-D Audio Amplifier with Variable Gain (TPA2010)	Class-D	Analog	Mono	Closed	2.5	—	4	2.5 to 5.5	0.2	—	75	N	DSBGA-9	1.20
TPA2011D1	3.2W mono Class-D with Auto-Recovering Short-Circuit Protection	Class-D	Analog	Mono	Closed	3.2	—	4	2.5 to 5.5	0.18	—	86	N	DSBGA-9	0.65
TPA2015D1	2W Class-D Audio Amplifier with Adaptive Boost and Battery Tracking SpeakerGuard™ AGC	Class-D	Analog	Mono	Closed	2	—	8	2.3 to 5.2	0.1	—	85	N	DSBGA-16	1.15
TPA2028D1	3.0W Mono Class-D Audio Amplifier with Fast Gain Ramp SmartGain™ AGC and DRC	Class-D	Analog	Mono	Closed	3	—	4	2.5 to 5.5	0.1	—	80	N	DSBGA-9	0.99
TPA2037D1	Fixed-Gain 3.2W Mono Class-D with Integrated DAC Noise Filter	Class-D	Analog	Mono	Closed	3.2	—	4	2.5 to 5.5	0.18	—	86	N	DSBGA-9	0.65
TPA2039D1	Fixed-Gain 3.2W Mono Class-D with Integrated DAC Noise Filter	Class-D	Analog	Mono	Closed	3.2	—	4	2.5 to 5.5	0.18	—	86	N	DSBGA-9	0.65
TPA2026D2	3.2W/Ch Stereo SmartGain Class-D Audio Amplifier with Dynamic Range	Class-D	Analog	Stereo	Closed	3.2	—	4	2.5 to 5.5	0.1	—	80	N	DSBGA-16	1.30
TPA2100P1	19Vpp Mono Class-D Audio Amplifier for Piezo/Ceramic Speakers (TPA2100)	Class-D	Analog	Mono	Closed	—	—	1.5μf Piezo	2.5 to 5.5	0.07	—	100	N	DSBGA-16	1.15
Amplifier Subsystems															
TPA2051D3	2.9W 3-Input Audio Subsystem with SmartGain Mono Class-D and DirectPath Headphone Amplifier	Class-AB	Analog	Stereo HP, Mono Speaker	Closed	2.9	0.025	4	2.5 to 5.5	0.05	80	75	N	DSBGA-25	0.75
TPA2054D4A	2.4W/Ch 3-Input Audio Subsystem with Stereo Class-D and DirectPath Headphone Amplifier	Class-AB	Analog	Stereo HP, Stereo Speaker	Closed	1.4	0.145	4	2.5 to 5.5	0.27	78.5	77.7	N	DSBGA-25	1.30
Speaker Amplifier – Portable – Digital Input															
Device	Description	Amplifier Class	Amplifier Input Type	Amplifier Output Type	Open/Closed Loop	Speaker Output Power (W)	Headphone Output Power (mW)	Load Impedance (Ω)	Analog Supply (V)	Digital Supply (V)	3-D/Bass Boost	Dynamic Range Control	HiRel Avail.	Package	Price*
TLV320DAC3120	Digital Input Class-D Speaker Amp with miniDSP	Class-D	I ² S	Mono	Closed	2.5	60	4	2.7 to 3.6	1.65 to 1.95	Y/Y	Y	N	5x5mm QFN-32	1.75

*Suggested resale price in U.S. dollars in quantities of 1,000.

Amplifiers and Comparators

→ Audio Amplifiers

Audio Amplifiers – Mid/High Power

Device	Description	Amplifier Class	Amplifier Input Type	Amplifier Output Type	Open/Closed Loop	Speaker Output Power (W)	Headphone Output Power (W)	Load Impedance (Ω)	Supply (V)	Half Power THD+N at 1kHz (%)	Speaker psRR (dB)	HiRel Avail.	Package(s)	Price*
Speaker Amplifiers – Mid/High Power – Analog Input														
TPA1517	Stereo, Medium Power, Class-AB Audio Amplifier	Class-AB	Analog	Stereo	Closed	6	—	4	9.5 to 18	0.15	65	N	PDIP-20, SO-20 PowerPAD™	1.15
TPA3002D2	9W Stereo Class-D Audio Power Amplifier with Volume Control (TPA3002)	Class-D	Analog	Stereo	Closed	9	—	8	8.5 to 14	0.06	80	N	HTQFP-48	3.65
TPA3003D2	3W Stereo Class-D Audio Power Amplifier with Volume Control (TPA3003)	Class-D	Analog	Stereo	Closed	3	—	8	8.5 to 14	0.2	80	N	TQFP-48	3.00
TPA3004D2	12W Stereo Class-D Audio Power Amplifier with Volume Control (TPA3004)	Class-D	Analog	Stereo	Closed	12	—	4	8.5 to 18	0.1	80	N	HTQFP-48	3.60
TPA3100D2	20W Stereo Class-D Audio Power Amplifier (TPA3100)	Class-D	Analog	Stereo	Closed	20	—	4	10 to 26	0.11	70	Y	HTQFP-48 VQFN-48	3.50
TPA3100D2-Q1	Automotive Catalog 20W Stereo Class-D Audio Power Amplifier	Class-D	Analog	Stereo	Closed	20	—	4	10 to 26	0.11	70	N	VQFN-48	4.45
TPA3101D2	10W Stereo Class-D Audio Power Amplifier (TPA3101)	Class-D	Analog	Stereo	Closed	10	—	4	10 to 26	0.09	70	N	HTQFP-48, VQFN-48	3.45
TPA3106D1	40W Mono Class-D Audio Power Amplifier (TPA3106)	Class-D	Analog	Mono	Closed	40	—	4	10 to 26	0.2	70	N	HLQFP-32	2.25
TPA3110D2	15W Filter-Free Class D Stereo Amplifier with SpeakerGuard™ (TPA3110)	Class-D	Analog	Stereo	Closed	15	—	4	8 to 26	0.07	70	N	HTSSOP-28	1.45
TPA3111D1	10W Mono Class-D Audio Power Amplifier with SpeakerGuard (TPA3111)	Class-D	Analog	Mono	Closed	10	—	4	8 to 26	0.07	70	N	HTSSOP-28	0.90
TPA3112D1	25W Filter-Free Mono Class-D Audio Amplifier with SpeakerGuard; (TPA3112)	Class-D	Analog	Mono	Closed	25	—	4	8 to 26	0.07	70	N	HTSSOP-28	0.85
TPA3113D2	6W Stereo Class-D Audio Power Amplifier with SpeakerGuard (TPA3113)	Class-D	Analog	Stereo	Closed	6	—	4	8 to 26	0.07	70	N	HTSSOP-28	0.85
TPA3121D2	15W Stereo Class-D Audio Power Amplifier with SE Outputs (TPA3121)	Class-D	Analog	Stereo	Closed	15	—	4	10 to 26	0.08	60	N	HTSSOP-24	1.45
TPA3123D2	25W Stereo Class-D Audio Power Amplifier with SE Outputs (TPA3123)	Class-D	Analog	Stereo	Closed	25	—	4	10 to 30	0.08	60	N	HTSSOP-24	1.75
TPA3124D2	15W Stereo Class-D Audio Power Amplifier with SE Outputs and Fast Mute Time (TPA3124)	Class-D	Analog	Stereo	Closed	15	—	4	10 to 26	0.08	60	N	HTSSOP-24	1.60
TAS5611A	125W Stereo/250W Mono PurePath™ HD™ Analog-Input Power Stage	Class-D	Analog	Up to 2 ch	Closed	125	—	4	10.8 to 13.2	0.03	80	N	HTQFP-64	4.30
TAS5613A	150W Stereo PurePath HD Analog-Input Power Stage	Class-D	Analog	Up to 2 Ch	Closed	150	—	4	10.8 to 13.2	0.03	80	N	HTQFP-64	4.90
TAS5630	Analog Input 300W Stereo (300W Total) Class-D Amplifier with Integrated Feedback	Class-D	Analog	Up to 4 Ch	Closed	600	—	4	10.8 to 13.2	0.03	80	N	HSSOP-44, HTQFP-64	6.00

*Suggested resale price in U.S. dollars in quantities of 1,000. See www.ti.com/hirel for HiRel options.

Amplifiers and Comparators

→ Audio Amplifiers

Audio Amplifiers – Mid/Hi-Power (continued)

Speaker Amplifiers – Mid/High Power – PWM Input/Powerstage

Device	Description	Amplifier Class	Amplifier Input Type	Amplifier Output Type	Open/Closed Loop	Speaker Output Power (W)	Load Impedance (Ω)	Supply (V)	Half Power THD+N at 1kHz (%)	Dynamic Range	HiRel Avail.	Package(s)	Price*
TAS5102	20W Stereo Digital Amplifier Power Stage	Class-D	PWM	Up to 4 Ch	Closed	20	4	8 to 26	<0.1	105	N	HTSSOP-32	1.80
TAS5103	15W Stereo Digital Amplifier Power Stage	Class-D	PWM	Up to 4 Ch	Closed	15	4	8 to 26	<0.1	105	N	HTSSOP-32	1.80
TAS5111A	70W Mono Digital Amplifier Power Stage	Class-D	PWM	Mono	Closed	70	4	16 to 30.5	0.025	95	N	HTSSOP-32	2.65
TAS5112A	50W Stereo Digital Amplifier Power Stage	Class-D	PWM	Stereo	Closed	50	6	16 to 30.5	0.025	95	N	HTSSOP-56	4.45
TAS5121	100W Mono Digital Amplifier Power Stage	Class-D	PWM	Mono	Closed	100	4	10.8 to 13.2	0.05	95	N	HTSSOP-32	3.55
TAS5122	50W Stereo Digital Amplifier Power Stage	Class-D	PWM	Stereo	Closed	30	6	16 to 25.5	0.05	95	N	HTSSOP-56	3.25
TAS5162	210W Stereo Digital Amplifier Power Stage	Class-D	PWM	Stereo	Closed	200	3	10.8 to 13.2	<0.05	110	N	HSSOP-36, HTSSOP-44	4.95
TAS5176	100W (5.1 Channel) Digital Amplifier Power Stage	Class-D	PWM	6 Ch	Closed	100	3	10.8 to 13.2	<0.05	109	N	HTSSOP-44	4.75
TAS5186A	210W (5.1-Channel) Digital Amplifier Power Stage	Class-D	PWM	6 Ch	Closed	30	3	10.8 to 13.2	0.07	105	N	HTSSOP-44	5.50
TAS5261	315W Mono Digital Amplifier Power Stage	Class-D	PWM	Mono	Closed	315	3	10.8 to 13.2	<0.05	110	N	HSSOP-36	5.25
TAS5342LA	100W Stereo Digital Amplifier Power Stage	Class-D	PWM	Up to 4 Ch	Closed	100	2	10.8 to 13.2	0.1	110	N	HTSSOP-44	3.05
TAS5352A	125W Stereo Digital Amplifier Power Stage	Class-D	PWM	Up to 4 Ch	Closed	125	2	10.8 to 13.2	0.06	110	N	HTSSOP-44	3.45
TAS5602	20W Stereo Digital Amp Power Stage w/Feedback	Class-D	PWM	Up to 4 Ch	Closed	20	4	10 to 26	<0.1	96	N	HTSSOP-44	2.00
TAS5612A	125W Stereo/250W Mono PurePath™ HD™ Digital-Input Power Stage	Class-D	PWM	Up to 2 Ch	Closed	125	4	10.8 to 13.2	0.03	103	N	HTQFP-64	4.30
TAS5614A	150W Stereo/300W Mono PurePath HD Digital-Input Power Stage	Class-D	PWM	Up to 2 Ch	Closed	150	4	10.8 to 13.2	0.03	103	N	HTQFP-64	4.45
TAS5631	PWM Input 300W Stereo (600W Total) Class-D Amplifier with Integrated Feedback	Class-D	PWM	Up to 4 Ch	Closed	600	4	10.8 to 13.2	0.04	110	N	HSSOP-44, HTQFP-64	6.90

Speaker Amplifiers – Mid/High Power – Digital Input

Device	Description	Amplifier Class	Amplifier Input Type	Amplifier Output Config.	Open/Closed Loop	Speaker Output Power (W)	Head-Phone Output Power (W)	Load Impedance (Ω)	Supply (V)	Half Power THD+N at 1kHz (%)	3-D/Bass Boost	Dynamic Range Control	HiRel Avail.	Package	Price*
TAS5704	20W Stereo Closed-Loop I ² S Audio Power Amplifier with Speaker EQ and DRC (H/W Controlled)	Class-D	I ² S	Stereo^2.1 ^4.0	Closed	20	—	4	10 to 26	<0.1	N/N	No	N	HTQFP-64	3.00
TAS5705	20W Stereo I ² S Audio Power Amplifier with Speaker EQ and DRC	Class-D	I ² S	Stereo^2.1	Closed	20	—	6	8 to 23	<0.1	N/N	2	N	HTQFP-64	2.70
TAS5706A	20W Stereo Closed-Loop I ² S Audio Power Amp w/Speaker EQ and DRC	Class-D	I ² S	Stereo^2.1	Closed	20	—	4	10 to 26	<0.1	N/N	2	N	HTQFP-64	3.00
TAS5706B	20W Closed-Loop I ² S Audio Power Amp w/ Speaker EQ, DRC and SE Output Support	Class-D	I ² S	Stereo^2.1 ^4.0	Closed	20	—	4	10 to 26	<0.1	N/N	2	N	HTQFP-64	3.00
TAS5707	20W Stereo I ² S Audio Power Amp with Speaker EQ and DRC	Class-D	I ² S	Stereo	Closed	20	—	6	8 to 26	<0.1	N/N	1	N	HTQFP-48	2.55
TAS5707A	20W Stereo Digital Audio Power Amplifier with EQ and DRC	Class-D	I ² S	Stereo	Closed	20	—	6	8 to 26	<0.1	N/N	1	N	HTQFP-48	2.30
TAS5708	20W Stereo Closed-Loop I ² S Audio Power Amp w/Speaker EQ and DRC	Class-D	I ² S	Stereo	Closed	20	—	6	10 to 26	<0.1	N/N	1	N	HTQFP-48	2.85
TAS5709	20W Stereo I ² S Audio Amplifier with Speaker EQ and 2-Band DRC	Class-D	I ² S	Stereo	Closed	20	—	6	8 to 26	<0.1	Y/Y	2	N	HTQFP-48	2.40
TAS5709A	20W Stereo I ² S Audio Amplifier with Speaker EQ and 2-Band DRC	Class-D	I ² S	Stereo	Closed	20	—	6	8 to 26	<0.1	Y/Y	2	N	HTQFP-48	2.65
TAS5710	20W Stereo Closed-Loop I ² S Audio Amp w/Speaker EQ and 2-Band DRC	Class-D	I ² S	Stereo	Closed	20	—	6	10 to 26	<0.1	Y/Y	2	N	HTQFP-48	2.65
TAS5711	20W Stereo I ² S Audio Amplifier with Speaker EQ, DRC and 2.1 Support	Class-D	I ² S	Stereo^2.1	Closed	20	—	4	8 to 26	<0.1	Y/N	2	N	HTQFP-48	2.75
TAS5713	25W Stereo I ² S Audio Amplifier with Speaker EQ and 2-Band DRC	Class-D	I ² S	Stereo	Closed	25	—	4	8 to 26	<0.1	N/Y	2	N	HTQFP-48	2.85
TAS5715	25W Stereo (BTL) I ² S Amp w/Speaker EQ, 2-Band DRC and DC Protection	Class-D	I ² S	Stereo	Closed	25	—	4	8 to 26	<0.1	N/Y	2	N	QFN-32	2.25
TAS5717	10W Digital Audio Power Amp w/ Integrated DirectPath™ Headphone Amp	Class-D	I ² S	Stereo	Closed	10	0.040/2Vrms	4	8 to 26	<0.1	N/N	2	N	QFN-32	2.25
TAS5719	15W Digital Audio Power Amp w/ Integrated DirectPath Headphone Amp	Class-D	I ² S	Stereo	Closed	15	0.040/2Vrms	4	8 to 26	<0.1	N/N	2	N	QFN-32	2.35

*Suggested resale price in U.S. dollars in quantities of 1,000.

Amplifiers and Comparators

→ Audio Amplifiers

Audio PWM Processors

Device	Description	Output Chs	Dynamic Range (dB)	Data Resolution	Dynamic Range	PWM Headphone Output	Volume Control	Serial Interface	Loudness Compensation	Mute	EQ	Bass/Treble Tone Control	HiRel Avail.	Package	Price*
TAS5001	Digital Audio PWM Processor	2	96	16, 20, 24	96	No	No	I ² S, R, L, DSP	No	Yes	No	No	N	TQFP-48	3.00
TAS5010	Digital Audio PWM Processor	2	96	16, 20, 24	96	No	No	I ² S, R, L, DSP	No	Yes	No	No	N	TQFP-48	3.75
TAS5012	Digital Audio PWM Processor	2	102	16, 20, 24	102	No	No	I ² S, R, L, DSP	No	Yes	No	No	N	TQFP-48	7.25
TAS5086	PurePath™ Digital™ Audio Six-Channel PWM Processor	6	105	16, 20, 24	105	No	Yes	I ² S, R, L	No	Yes	Yes	No	N	TSSOP-38	1.90
TAS5508C	8-Channel Digital Audio PWM Processor	8	102	16, 20, 24	102	Yes	Yes	I ² S, R, L	Yes	Yes	Yes	Yes	N	TQFP-64	5.00

Audio Operational Amplifiers

Device	Description	Amplifier Type	No. of Chs	Supply Min (V+ + V-)	Supply Max (V+ + V-)	I _q per Channel (max) (mA)	GBW (typ) (MHz)	Slew Rate (typ) (V/μs)	V _n at 1kHz (typ) (nV/√Hz)	Distortion at 1kHz (typ) (%)	HiRel Avail.	Package(s)	Price*
Audio Operational Amplifiers													
THS4521	High-Speed Operational Amplifiers	Bipolar Differential Amplifier	1	2.5	5.5	1.25	95	490	4.6	0.000250%	N	MSOP-8, SOIC-8	1.10
THS4522	Very Low Power Dual Channel Rail-to-Rail Output Fully Differential Amplifier	Bipolar Differential Amplifier	2	2.5	5.5	1.25	95	490	4.6	0.000250%	N	TSSOP-16	1.85
THS4524	Very Low Power Quad Channel Rail-to-Rail Output Fully Differential Amplifier	Bipolar Differential Amplifier	4	2.5	5.5	1.25	95	490	4.6	0.000250%	N	TSSOP-38	3.15
Bipolar Differential Amplifiers													
OPA1632	Fully Differential I/O Audio Amplifier	Bipolar Differential Amplifier	1	5	32	14	180	50	4.6	0.000022%	N	SOIC-8, MSOP-8, PowerPAD™	1.75
OPA1611	1.1nV/√Hz Noise, Low Power, Precision Operational Amplifier	Bipolar Operational Amplifier	1	5	36	3.6	40	27	4.6	0.000015%	N	SOIC-8	1.75
OPA1612	1.1nV/√Hz Noise, Low Power, Precision Operational Amplifier	Bipolar Operational Amplifier	2	5	36	3.6	40	27	4.6	0.000015%	N	SOIC-8	2.75
OPA1602	2.5nV/√Hz Noise, Low Power, Precision Operational Amplifier	Bipolar Operational Amplifier	1	5	36	2.6	35	20	2.5	0.000030%	N	SO, MSOP	1.45
OPA1604	2.5nV/√Hz Noise, Low Power, Precision Operational Amplifier	Bipolar Operational Amplifier	4	5	36	2.6	35	20	2.5	0.000030%	N	SO, MSOP	1.95
OPA2228	3nV/√Hz Noise, Low Power, Precision Operational Amplifier	Bipolar Operational Amplifier	1	5	36	3.8	33	11	3	0.000050%	N	PDIP-8, SOIC-8	1.85
OPA4228	3nV/√Hz Noise, Low Power, Precision Operational Amplifier	Bipolar Operational Amplifier	4	5	36	3.8	33	11	3	0.000050%	N	PDIP-14, SOIC-14	4.05
NE5534	3.5nV/√Hz Noise, Precision Operational Amplifier	Bipolar Operational Amplifier	1	10	30	8	10	13	4	0.002	N	PDIP-8, SO-8, SOIC-8	0.45
NE5532	3.5nV/√Hz Noise, Precision Operational Amplifier	Bipolar Operational Amplifier	2	10	30	4	10	9	5	0.002	N	PDIP-8, SO-8, SOIC-8	0.45
MC33078	High-Speed Low-Noise Operational Amplifier	Bipolar Operational Amplifier	2	10	36	2.5	16	7	4.5	0.002	Y	MSOP-8, PDIP-8, SOIC-8	0.30

*Suggested resale price in U.S. dollars in quantities of 1,000. See www.ti.com/hirel for HiRel options.

Preview products are listed in bold blue.

Audio Operational Amplifiers (continued)

Device	Description	Amplifier Type	No. of Chs	Supply Min ([V+] + [V-])	Supply Max ([V+] + [V-])	I _Q per Channel (max) (mA)	GBW (typ) (MHz)	Slew Rate (typ) (V/μs)	V _n at 1kHz (typ) (nV/√Hz)	Distortion at 1kHz (typ) (%)	HiRel Avail.	Package(s)	Price*
FET Operational Amplifiers													
OPA827	Low-Noise, High-Precision, JFET-Input Operational Amplifier	FET Operational Amplifier	1	8	36	5.2	22	28	4	0.000040%	N	MSOP-8, SOIC-8	3.75
OPA627	Precision High-Speed Difet™ Operational Amplifiers	FET Operational Amplifier	1	9	36	7.5	16	55	5.6	0.000030%	N	PDIP-8, SOIC-8	12.25
OPA1641	SoundPlus™ High-Performance, JFET-Input Audio Operational Amplifier	FET Operational Amplifier	1	5	36	2.3	11	20	5.1	0.000050%	N	MSOP-8, SOIC-8	0.95
OPA1641	SoundPlus High-Performance, JFET-Input Audio Operational Amplifier	FET Operational Amplifier	1	5	36	2.3	11	20	5.1	0.000050%	N	MSOP-8, SOIC-8	0.95
OPA1642	SoundPlus High-Performance, JFET-Input Audio Operational Amplifier	FET Operational Amplifier	2	5	36	2.3	11	20	5.1	0.000050%	N	MSOP-8, SOIC-8	1.45
OPA1644	SoundPlus High-Performance, JFET-Input Audio Operational Amplifier	FET Operational Amplifier	4	5	36	2.3	11	20	5.1	0.000050%	N	SOIC-14, TSSOP-14	1.95
OPA134	SoundPlus High-Performance, JFET-Input Audio Operational Amplifier	FET Operational Amplifier	1	5	36	5	8	20	8	0.000080%	N	PDIP-8, SOIC-8	1.10
OPA2134	SoundPlus High-Performance, JFET-Input Audio Operational Amplifier	FET Operational Amplifier	2	5	36	5	8	20	8	0.000080%	N	PDIP-8, SOIC-8	1.25
OPA4134	SoundPlus High-Performance, JFET-Input Audio Operational Amplifier	FET Operational Amplifier	4	5	36	5	8	20	8	0.000080%	N	SOIC-14	2.00
OPA604	FET-Input, Audio Operational Amplifier	FET Operational Amplifier	1	9	48	7	20	25	11	0.000300%	N	PDIP-8, SOIC-8	1.05
OPA2604	Dual FET-Input, Low Distortion Operational Amplifier	FET Operational Amplifier	2	9	48	6	20	25	11	0.000300%	Y	PDIP-8, SOIC-8	1.90
OPA353	High-Speed, Single-Supply, Rail-to-Rail Operational Amplifiers	FET Operational Amplifier	1	2.7	5.5	8	44	22	18	0.000600%	N	5SOT-23, SOIC-8	1.00
OPA2353	High-Speed, Single-Supply, Rail-to-Rail Operational Amplifiers	FET Operational Amplifier	2	2.7	5.5	8	44	22	18	0.000600%	N	MSOP-8, SOIC-8	1.70
OPA4353	High-Speed, Single-Supply, Rail-to-Rail Operational Amplifiers	FET Operational Amplifier	4	2.7	5.5	8	44	22	18	0.000600%	N	SOIC-14, SSOP-16/ QSOP	2.50
OPA343	Single-Supply, Rail-to-Rail Operational Amplifiers	FET Operational Amplifier	1	2.5	5.5	1.25	5.5	6	25	0.000700%	N	5SOT-23, SOIC-8	0.65
OPA2343	Single-Supply, Rail-to-Rail Operational Amplifiers	FET Operational Amplifier	2	2.5	5.5	1.25	5.5	6	25	0.000700%	N	MSOP-8, SOIC-8	1.00
OPA4343	Single-Supply, Rail-to-Rail Operational Amplifiers	FET Operational Amplifier	4	2.5	5.5	1.25	5.5	6	25	0.000700%	N	SOIC-14, TSSOP-14, SSOP-16/ QSOP	1.85
TL072	Low-Noise JFET-Input General-Purpose Operational Amplifier	FET Operational Amplifier	1	7	36	2.5	3	8	18	0.003000%	N	PDIP-8, SO-8, SOIC-8, 8TSSOP	0.29
TL074	Low-Noise JFET-Input General-Purpose Operational Amplifier	FET Operational Amplifier	4	7	36	2.5	3	8	18	0.003000%	N	PDIP-14, SO-14, SOIC-14, TSSOP-14	0.22

*Suggested resale price in U.S. dollars in quantities of 1,000. See www.ti.com/hirel for HiRel options.

Instrumentation Amplifiers

Low Noise Instrumentation Amplifiers for Industrial Applications

PREVIEW*

INA826

Contact your TI sales representative for more information.

Key Features

- Low offset voltage: 200 μ V
- Robust input architecture:
 - Extended input voltage range: $V_{cc} - 0.8V$
 - $\pm 40V$ input protection
 - EMI hardened
- Excellent AC performance
 - CMRR (G = 1): 90dB min
 - Input noise: $16nV/\sqrt{Hz}$
- Industrial supply:
 - +2.7 to +36V, $\pm 1.35V$ to $\pm 18V$
 - Low power: 200 μ A
 - Rail-to-rail output
 - -40 to +125 $^{\circ}C$
- 8-MSOP, 8-DFN, and 8-SOIC

The INA826 36V instrumentation amplifier enables accurate sensor measurement in the industrial environment by combining 200 μ V offset voltage and input common mode range beyond the power supply rails. Operating from 2.7V to 36V on 200 μ A operating current, the INA826 makes it easy to achieve precision measurements in single and bipolar supply applications.

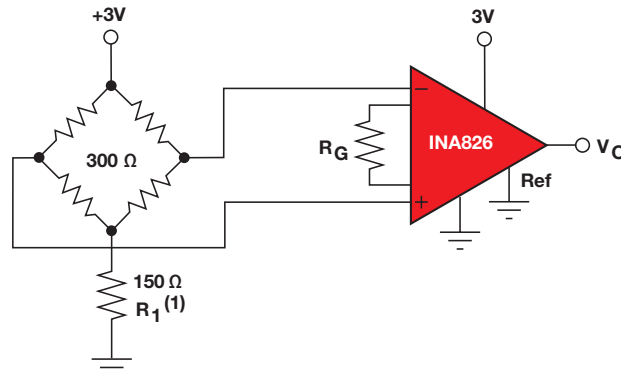

INA826 functional block diagram

*Expected release date: Q2 2011

Applications

- Industrial process controls
- Circuit breakers
- Medical instrumentation
- Portable data acquisition

Zero Drift, HV Programmable Gain Amplifier

PGA280

Get samples, datasheets and app reports at: www.ti.com/sc/device/PGA280

Key Features

- Wide input range: $\pm 15.5V$ at $\pm 18V$ supply
- Binary gain steps: 128V/V to 1/8V/V
- Low offset voltage: 3 μ V at G=128
- Near-zero gain drift: 0.5ppm/ $^{\circ}C$
- Excellent linearity: 1.5ppm
- Excellent CMRR: 140dB
- High input impedance
- Very low 1/f noise
- Differential signal output
- Overload detection
- Input configuration switch matrix
- Wire break test current
- Expandable SPI™ with checksum
- General-purpose I/O port
- TSSOP-24 package

The PGA280 is a high-precision instrumentation amplifier with digitally-controllable gain and signal integrity test capability. This device offers low offset voltage, near-zero offset and gain drift, excellent linearity, and nearly no 1/f noise with superior common-mode and supply rejection to support high-resolution precision measurement. The 36V supply capability and wide, high-impedance input range comply with requirements for universal signal measurement.

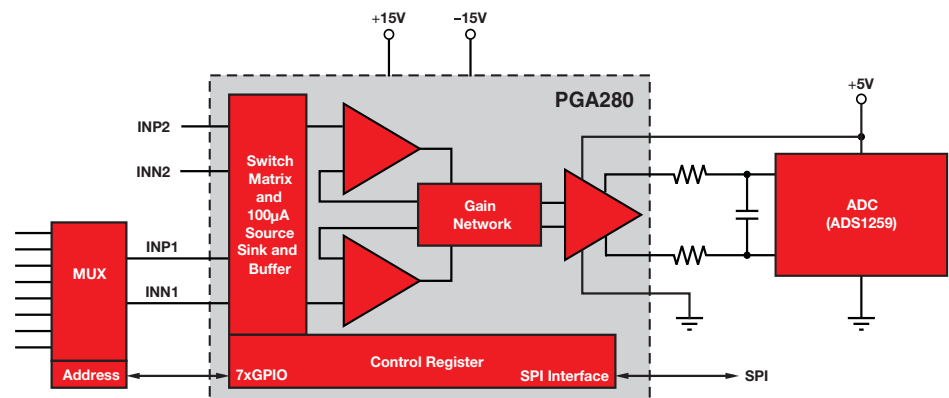

PGA280 block diagram

Applications

- High-precision signal instrumentation
- Multiplexed data acquisition
- High-voltage analog input amplifier
- Universal industrial analog input

Amplifiers and Comparators

Instrumentation Amplifiers

Instrumentation Amplifiers

Device	Description	Gain	Non Linearity (%) (max)	Input Bias Current (nA) (max)	Offset at G = 100 (μV) (max)	Offset Drift (μV/°C) (max)	CMRR at G = 100 (dB) (min)	BW at G = 100 (kHz) (min)	Noise 1kHz (nV/√Hz) (typ)	Power Supply (V)	I _Q Per Amp (mA) (max)	HiRel Avail.	Package(s)	Price*
Single Supply: V_{smax} <= 5.5V														
INA333	Zero Drift, Low Power, Precision	1 to 10000	0.00001	0.2	25	0.1	100	3.5	50	1.8 to 5.5	0.075	Y	MSOP-8, DFN-8	1.80
INA337	RRIO, Auto-Zero, Low Drift	0.1 to 10000	0.01	2	100	0.4	106	1	33	2.7 to 5.5	3.4	N	MSOP-8	1.95
INA338	RRIO, Auto-Zero, Shutdown	0.1 to 10000	0.01	2	100	0.4	106	1	33	2.7 to 5.5	3.4	N	MSOP-10	2.10
INA326	CM >Supply, Wide Temp	0.1 to 10000	0.01	2	100	0.4	100	1	33	2.7 to 5.5	3.4	N	MSOP-8	1.95
INA327	RRIO, Auto-Zero, Low Drift	0.1 to 10000	0.01	2	100	0.4	100	1	33	2.7 to 5.5	3.4	N	MSOP-10	2.10
INA155	CM >Supply, SHDN, Wide Temp	10, 50	0.02	0.01	1000	5	92	110	40	2.7 to 5.5	2.1	N	SO-8, MSOP-8	1.10
INA2321	RRIO, Auto-Zero, CM > Supply, Low Drift	5 to 1000	0.01	0.01	500	7	90	50	100	2.7 to 5.5	0.06	N	TSSOP-14	1.75
INA321	RRIO, Auto-Zero, SHDN	5 to 1000	0.01	0.01	500	7	90	50	100	2.7 to 5.5	0.06	N	MSOP-8	1.10
INA331	Low-Power, Single-Supply, CMOS	5 to 1000	0.01	0.01	500	5	90	2000	46	2.7 to 5.5	0.49	N	MSOP-8	1.10
INA2331	CM >Supply, Low Drift	5 to 1000	0.01	0.01	1000	5	80	2000	46	2.7 to 5.5	0.49	N	TSSOP-14	1.80
INA156	Zero Drift, Low Power, Precision	10, 50	0.02	0.01	8000	5	74	110	40	2.7 to 5.5	2.5	N	MSOP-8	0.95
INA2322	Low Offset, RRO, Wide Temp, SR = 6.5V/μs	5 to 1000	0.01	0.01	10000	7	60	50	100	2.7 to 5.5	0.06	N	TSSOP-14	1.65
INA2332	Dual INA321	5 to 1000	0.01	0.01	8,000	7	60	500	46	2.7 to 5.5	0.49	N	TSSOP-14	1.45
INA322	RRO, SHDN, Wide Temp, Low Cost	5 to 1000	0.01	0.01	10,000	7	60	50	100	2.7 to 5.5	0.06	N	MSOP-8	0.95
INA332	RRO, Wide BW, SHDN, Wide Temp, Low Cost	5 to 1000	0.01	0.01	8,000	7	60	500	46	2.7 to 5.5	0.49	N	MSOP-8	0.90
INA330	Optimized for Precision 10kΩ Thermistor Applications	—	—	0.23	—	0.009°C	—	1	0.0001°C	2.7 to 5.5	3.6	N	MSOP-10	1.65
Wide Supply: V_{smax} <= 36V														
INA826	Precision RRIO 36V	1 to 1000	0.01	0.37	200	1	110	1100	18	2.7 to 36V	0.25	N	MSOP-8, SO-8, QFN	Web
INA128	Precision, Low Noise, Low Drift	1 to 10000	0	5	60	0.7	120	200	8	±2.25 to ±18	0.75	N	DIP-8, SOIC-8	3.05
INA129	Precision, Low Noise, Low Drift, AD620 Second Source	1 to 10000	0	5	60	0.7	120	200	8	±2.25 to ±18	0.75	Y	DIP-8, SOIC-8	4.45
INA1412	Precision, Low Noise, Low Power, Pin Compatible with AD62121	10, 100	0	5	50	0.5	117	200	8	±2.25 to ±18	0.8	N	DIP-8, SOIC-8	3.55
INA114	Precision, Low Drift	1 to 10000	0	2	50	0.25	110	10	11	±2.25 to ±18	3	N	DIP-8, SO-16	4.80
INA115	Precision, Low Drift, w/Gain Sense Pins	1 to 10000	0	2	50	0.25	110	10	11	±2.25 to ±18	3	N	SO-16	4.20
INA131	Low Noise, Low Drift	100	0	2	50	0.25	110	70	12	±2.25 to ±18	3	N	DIP-8	3.80
INA118	Precision, Low Drift, Low Power	1 to 10000	0	5	55	0.7	107	70	10	±1.35 to ±18	0.39	N	DIP-8, SOIC-8	4.80
INA110	Fast Settle, Low Noise, Wide BW	1, 10, 100, 200, 500	0.01	0.05	1000	2.5	106	470	10	±6 to ±18	4.5	N	DIP-16, SOIC-16	7.00
INA111	Fast Settle, Low Noise, Wide BW	1 to 1000	0.01	0.02	520	6	106	450	10	±6 to ±18	4.5	N	DIP-8, SO-16	4.20
INA101	Low Noise, Wide BW, Gain Sense Pins, Wide Temp	1 to 1000	0	20	250	0.25	100	25	13	±5 to ±20	8.5	N	PDIP-14, SO-16	7.95
INA103	Precision, Fast Settle, Low Drift, Audio, Mic Pre-Amp, THD+N = 0.0009%	1 to 1000	0	12000	255	1.23	100	800	1	±9 to ±25	12.5	N	DIP-16, SO-16	5.00
INA125	Internal Ref, Sleep Mode	4 to 10000	0.01	25	250	2	100	4.5	38	±1.35 to ±18	0.53	N	DIP-16, SOIC-16	2.05
INA163	Precision, Fast Settle, Low Drift, Audio, Mic Pre Amp, THD+N = 0.002%	1 to 10000	0	12000	300	1.23	100	800	1	±4.5 to ±18	12	N	SOIC-14	2.90

*Suggested resale price in U.S. dollars in quantities of 1,000. See www.ti.com/hi-rel for HiRel options.

New products are listed in bold red. Preview products are listed in bold blue.

Amplifiers and Comparators

Instrumentation Amplifiers

Instrumentation Amplifiers (continued)

Device	Description	Gain	Non Linearity (%) (max)	Input Bias Current (nA) (max)	Offset at G = 100 (μV) (max)	Offset Drift (μV/°C) (max)	CMRR at G = 100 (dB) (min)	BW at G = 100 (kHz) (min)	Noise at 1kHz (nV/√Hz) (typ)	Power Supply (V)	I _Q Per Amp (mA) (max)	HiRel Avail.	Package(s)	Price*
Wide Supply: V_{max} <= 36V														
INA166	Precision, Fast Settle, Low Drift, Audio, Mic Pre-Amp, THD+N = 0.09%	2000	0.01	12000	300	2.53	100	450	1.3	±4.5 to ±18	12	N	SO-14	5.95
INA217	Precision, Low Drift, Audio, Mic Pre-Amp, THD+N = 0.09%, SSM2017 Replacement	1 to 10000	0	12000	300	1.23	100	800	1.3	±4.5 to ±18	12	N	DIP-8, SO-16	2.50
INA125	Internal Ref, Sleep Mode	4 to 10000	0.01	25	250	2	100	4.5	38	2.7 to 36	0.53	N	DIP-16, SOIC-16	2.05
INA121	Low Bias, Precision, Low Power	1 to 10000	0.01	0.05	500	5	96	50	20	±2.25 to ±18	0.53	N	DIP-8, SO-8	2.50
INA116	Ultra-Low IB 3fA (typ), with Buffered Guard Drive Pins	1 to 1000	0.01	0	5000	40	86	70	28	±4.5 to ±18	1.4	N	DIP-16, SO-16	4.20
INA122	μPower, RRO, CM to GND	5 to 10000	0.01	25	250	3	83	5	60	±1.3 to ±18	0.09	N	DIP-8, SOIC-8	2.45
INA126	μPower, <1V VSAT, Low Cost	5 to 10000	0.01	25	250	3	83	9	35	2.7 to 36	0.2	N	DIP/SO/MSOP-8	1.15
INA2126	Dual INA126	5 to 10000	0.01	25	250	3	83	9	35	2.7 to 36	0.2	N	DIP/SO/MSOP-16	1.85
Digitally Programmable Gain Amplifiers														
Device	Description	Gain	Non Linearity at G = 100 (%) (max)	Offset (μV) (max)	Offset Drift (μV/°C) (max)	CMRR at G = 100 (dB) (min)	BW at G = 100 (kHz) (typ)	Noise at 1kHz (nV/√Hz) (typ)	Power Supply (V)	I _Q (mA) (max)	HiRel Avail.	Package(s)	Price*	
PGA103	Precision, Single-Ended Input	1, 10, 100	0.01	500	2 (typ)	—	250	11	±4.5 to ±18	3.5	N	SOIC-8	4.35	
PGA202	High Speed, FET-Input, 50pA I _B	1, 10, 100, 1000	0.012	1000	12	92	1000	12	±6 to ±18	6.5	N	DIP-14	7.75	
PGA203	High Speed, FET-Input, 50pA I _B	1, 2, 4, 8	0.012	1000	12	92	1000	12	±6 to ±18	6.5	N	DIP-14	7.75	
PGA204	High Precision, Gain Error: 0.25%	1, 10, 100, 1000	0.002	50	0.25	110	10	13	±4.5 to ±18	6.5	N	SOIC-16, PDIP-16	8.35	
PGA205	Gain Drift: 0.024ppm/°C	1, 2, 4, 8	0.002	50	0.25	95	100	15	±4.5 to ±18	6.5	N	SOIC-16, PDIP-16	8.35	
PGA206	High Speed, FET-Input, 100pA I _B	1, 2, 4, 8	0.002	1500	2 (typ)	95	600	18	±4.5 to ±18	13.5	N	DIP-16, SOIC-16	10.80	
PGA207	High Speed, FET-Input, 100pA I _B	1, 2, 5, 10	0.002	1500	2 (typ)	95	600	18	±4.5 to ±18	13.5	N	DIP-16, SOIC-16	11.85	
PGA112/3	Zero-Drift, Precision PGA with 2Ch MUX	1 to 200	—	100	0.9	—	380	12	+2.2V to +5.5V	0.45	N	MSOP-10	1.00	
PGA116/7	Zero-Drift, Precision PGA with 10Ch MUX	1 to 200	—	100	1.2	—	380	12	+2.2V to +5.5V	0.45	N	TSSOP-20	1.83	
PGA309	0.1% Digitally Calibrated Bridge Sensor Conditioner, Voltage Output	8 to 1152	0.002	50	0.2	20	60	210	+2.7 to +5.5	1.6	N	TSSOP-16	2.95	
PGA308	Single Supply, Auto-Zero, Sensor Amplifier w/Programmable Gain and Offset	4 to 1600	—	40	0.2	95	100	50	+2.7 to +5.5	2	N	MSOP-10, DFN-10	2.00	
PGA280	High Voltage, Wide Input Range, Zero-Drift PGA	1/8 to 128	0.0010	15	0.17	140	6000	22	±5 to ±18 2.7 to 5.5	7.13	N	TSSOP-24	2.90	

*Suggested resale price in U.S. dollars in quantities of 1,000.

New products are listed in bold red.

Amplifiers and Comparators

Instrumentation Amplifiers

Single-Supply, High-Speed, Precision Logarithmic Amplifier

LOG114

Get samples and datasheets at: www.ti.com/sc/device/LOG114

Key Features

- Advantages:
 - Tiny for high-density systems
 - Precision on one supply
 - Fast over eight decades
 - Fully tested function
- Two scaling amplifiers
- Wide input dynamic range: eight decades, 100pA to 10mA
- 2.5V reference
- Stable over temperature
- Low quiescent current: 10mA
- Dual or single supply: ±5V, +5V
- Specified temperature range: -5°C to +75°C
- Package: small QFN-16 (4mm x 4mm)

Applications

- Onet erbium-doped fiber optic amplifiers (EDFA)
- Laser optical density measurement
- Photodiode signal compression amps
- Log, log-ratio functions
- Analog signal compression in front of analog-to-digital converters
- Absorbance measurement

The LOG114 is specifically designed for measuring low-level and wide dynamic range currents in communications, lasers, medical and industrial systems. The device computes the logarithm or log-ratio of an input current or voltage relative to a reference current or voltage (logarithmic transimpedance amplifier).

High precision is ensured over a wide dynamic range of input signals on either Bipolar (±5V) or single (+5V) supply. Special temperature drift compensation circuitry is included on-chip. In log-ratio applications, the signal current may be from a high impedance source such as a photodiode or resistor in series with a low impedance voltage source. The reference current is provided by a resistor in series with a precision internal voltage reference, photo diode or active current source.

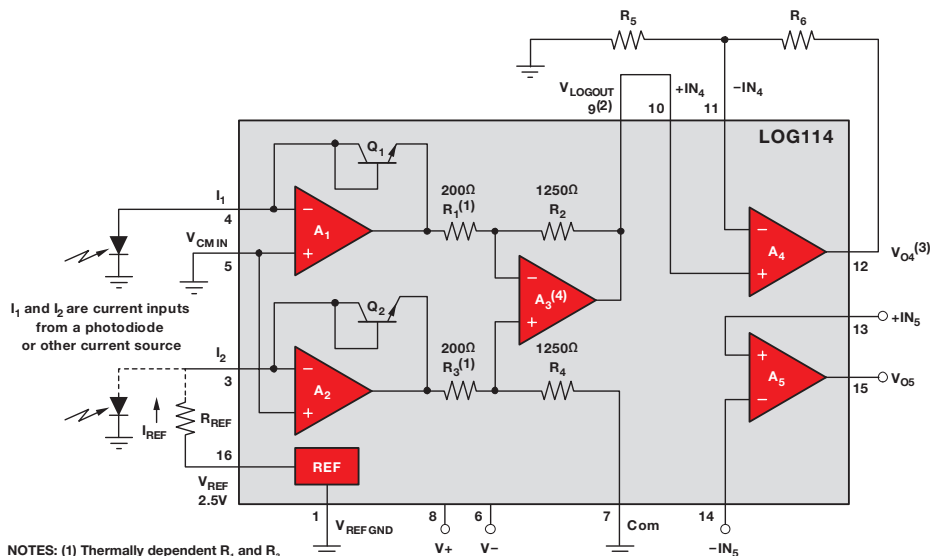

NOTES: (1) Thermally dependent R_1 and R_3 provide temperature compensation.
 (2) $V_{\text{LOGOUT}} = 0.375 \times \log(I_1/I_2)$
 (3) $V_{\text{OUT}} = 0.375 \times K \times \log(I_1/I_2)$
 $K = 1 + R_5/R_6$
 (4) Differential Amplifier (A) Gain = 6.25

LOG114 functional block diagram

Logarithmic Amplifiers

Device	Scale Factor (V/Decade)	Input Current Range (nA) (min)	Input Current Range (mA) (max)	Conformity Error (Initial 5 Decades) (%) (max)	Conformity Error (Initial 5 Decades) (%/°C) (typ/temp)	Bandwidth (kHz)	V_S (V) (min)	V_S (V) (max)	I_Q Per Ch. (mA) (max)	Reference Type	Auxiliary Op Amps	HiRel Avail.	Package	Price*
LOG101	1	0.1	3.5	0.2	0.0001	38	9	36	1.5	External	—	N	S0-8	6.95
LOG102	1	1	1	0.3	0.0002	38	9	36	2	External	2	N	S0-14	7.25
LOG104	0.5	0.1	3.5	0.2	0.0001	38	9	36	1.5	External	—	N	S0-8	6.95
LOG112	0.5	0.1	3.5	0.2	0.0001	38	9	36	1.75	2.5V Internal	1	N	S0-14	7.90
LOG2112	0.5	0.1	3.5	0.2	0.0001	38	9	36	1.75	2.5V Internal	1/Ch	N	S0-16	11.35
LOG114	0.375	0.1	10	0.2	0.001	5000	5	10	15	2.5V Internal	2	N	QFN-16	7.90

*Suggested resale price in U.S. dollars in quantities of 1,000.

New products are listed in bold red.

→ Power Amplifiers and Buffers

1.5A, High-Current Power Amplifier

OPA564

Get datasheets, evaluation modules and app reports at: www.ti.com/sc/device/OPA564

Key Features

- Single or dual supply: $\pm 3.5\text{V}$ (7V) to $\pm 13\text{V}$ (26V)
- Large output swing: 22V_{PP} at 1.5A (24V supply)
- Thermal and over-current warning
- Adjustable current limit
- Output enable/disable control
- Slew rate: $20\text{V}/\mu\text{s}$
- Packaging: HSOP-20 PowerPAD™

The OPA564 is a high-current operational amplifier ideal for driving up to 1.5A in reactive loads and provides high reliability in demanding power-line communications and motor control applications. It operates from a single or dual power supply of $\pm 3.5\text{V}$ (7V) to $\pm 13\text{V}$ (26V). In single-supply operation, the input common-mode range extends below ground. The OPA564 is easy to heat sink over the specified extended industrial temperature range, -40°C to $+125^\circ\text{C}$.

Applications

- Power-line communications
- Valve, actuator drivers
- Synchro, servo drivers
- Motor drivers
- Power supply output amplifiers
- Test equipment
- Transducer excitation
- General-purpose linear power boosters

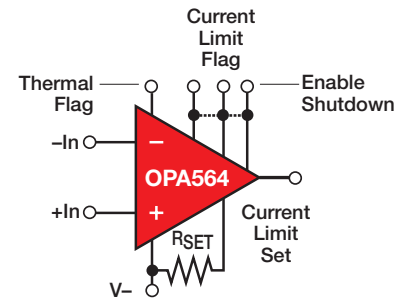

OPA564 PowerPAD™-down pinout

Power Amplifiers

Device	I_{OUT} (A)	V_{S} (V)	Bandwidth (MHz)	Slew Rate (V/ μs)	I_{Q} (mA) (max)	V_{OS} (mV) (max)	V_{OS} Drift ($\mu\text{V}/^\circ\text{C}$) (max)	I_{B} (nA) (max)	HiRel Avail.	Package(s)	Price*
OPA445	0.015	20 to 90	2	15	4.7	5	10	0.1	N	DIP-8, SO-8, SO-8 PowerPAD™	4.75
OPA452	0.05	20 to 80	1.8	7.2	6.5	3	5	0.1	N	T0220-7, DDPak-7	2.55
OPA453	0.05	20 to 80	7.5	23	6.5	3	5	0.1	N	T0220-7, DDPak-7	2.55
OPA454	0.025	10 to 100	2.5	13	4	4	10	0.1	N	SO-8 and HSOP-20 PowerPAD	2.75
OPA541	10	20 to 70	1.6	10	25	10	40	0.05	N	T0220-11, T03-8	11.10
OPA544	2	20 to 70	1.4	8	15	5	10	0.1	N	T0220-5, DDPak-5	7.90
OPA2544	2	20 to 70	1.4	8	15	5	10	0.1	N	T0220-11	12.00
OPA547	0.5	8 to 60	1	6	15	5	25	500	N	T0220-7, DDPak-7	5.00
OPA548	3	8 to 60	1	10	20	10	30	500	N	T0220-7, DDPak-7	6.90
OPA549	8	8 to 60	0.9	9	35	5	20	500	N	ZIP-11, T0220-11	12.00
OPA551	0.2	8 to 60	3	15	8.5	3	7	0.1	N	DIP-8, SO-8, DDPak-7	1.90
OPA552	0.2	8 to 60	12	24	8.5	3	7	0.1	N	DIP-8, SO-8, DDPak-7	1.75
OPA561	1.2	7 to 16	17	50	60	20	50	0.1	N	HTSSOP-20	2.80
OPA564	1.5	7 to 28	4	20	35	20	10	0.1	N	HSOP-20 PowerPAD	2.75
OPA567	2	2.7 to 5.5	1.2	1.2	6	2	1.3	0.01	N	QFN-12	1.85
OPA569	2	2.7 to 5.5	1.2	1.2	6	2	1.3	0.01	N	SO-20 PowerPAD	3.10

Buffers (Sorted by Ascending BW at A_{CL})

Device	V_{S} ± 15 (V)	V_{S} ± 5 (V)	V_{S} 3.3 (V)	V_{S} 5 (V)	A_{CL} Stable Gain (V/V) (min)	BW at A_{CL} (MHz)	Slew Rate (V/ μs)	Settling Time 0.01% (ns) (typ)	I_{Q} (mA) (typ)	THD ($F_{\text{c}} = 1\text{MHz}$) (dB) (typ)	Diff Gain (%)	Diff Phase ($^\circ$)	V_{N} at Flatband (nV/ $\sqrt{\text{Hz}}$) (typ)	V_{OS} (mV) (max)	I_{B} (μA) (max)	HiRel Avail.	Package(s)	Price*
OPA633	Yes	Yes	—	—	1	260	2500	50	21	—	—	0.1	—	15	35	N	DIP-8	5.45
OPA692	—	Yes	—	Yes	1	280	2000	12 (0.02%)	5.8	-78	0.07	0.02	1.7	2.5	35	N	SOT-23-6, SOIC-8	1.15
OPA693	—	Yes	—	Yes	1	1400	2500	12 (0.1%)	13	-84	0.03	0.01	1.8	2	35	N	SOT-23-6, SOIC-8	1.30
OPA832	—	Yes	Yes	Yes	1	92	350	45 (0.1%)	4.25	-84	0.1	0.16	9.2	7	10	N	SOT-23-5, SOIC-8	0.32
BUF602	—	Yes	Yes	Yes	1	1000	8000	6 (0.05%)	5.8	—	0.15	0.04	4.8	30	7	N	SOT-23-5, SOIC-8	0.85
BUF634	Yes	Yes	Yes	Yes	1	30 to 180	2000	200 (0.1%)	15	—	0.4	0.1	4	100	20	N	DIP-8, SOIC-8 T0220-5, DDPak-5	3.10

*Suggested resale price in U.S. dollars in quantities of 1,000.

New products are listed in bold red.

Voltage References and Comparators

→ Comparators

Low-Power, High-Speed Comparator in Micro-Packages

TLV3201

Get samples and datasheets at: www.ti.com/sc/device/TLV3201

Key Features

- Fast response time: 35nS
- Low quiescent current: 40µA
- Precision input: 1mV V_{OS} typ
- Rail-to-rail inputs
- Push-pull and open-drain outputs
- Single and dual channel options in microSize packaging:
 - Single: SC70 and SOT23
 - Dual: µDFN and MSOP-8
- Supply range: 2.2V to 5.5V

Applications

- Inspection equipment
- Test and measurement
- High-speed sampling systems
- Telecom
- Basestations
- Portable communications

The TLV3201 low-power comparator combines best-in-class response time (40ns) with 40µA consumption making it easy to use one comparator for multiple sockets. At a competitive price and pin-to-pin compatible with standard comparator pinout, the TLV3201 simplifies device selection and inventory management.

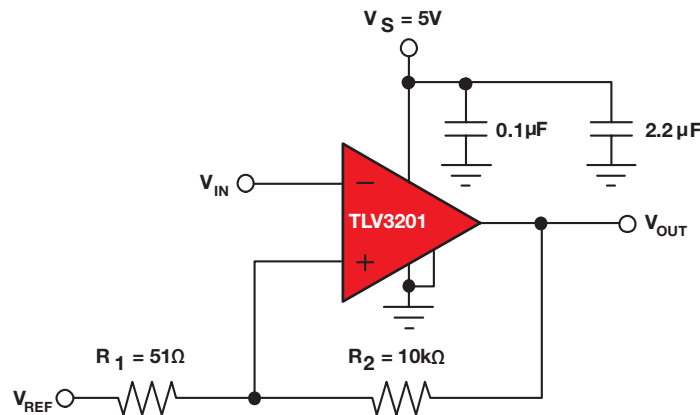

TLV3201 PowerPAD™-down pinout

Comparators

Device	Description	Ch.	I_Q Per Ch. (mA) (max)	Output Current (mA) (min)	t_{RESP} Low-to-High (µs)	V_S (V) (min)	V_S (V) (max)	V_{OS} (25°C) (mV) (max)	Output Type	HiRel Avail.	Package(s)	Price*
TLV3501	Ultra-High Speed, Low Power	1, 2	5	20	0.004	2.7	5.5	5	Push-Pull	Y	SOT-23	1.50
TL714	High Speed, 10mV (typ) Hysteresis	1	12	16	0.006	4.75	5.25	10	Push-Pull	N	PDIP, SOIC	2.16
TL3116	Ultra Fast, Low Power, Precision	1	14.7	5	0.0099	5	10	3	Push-Pull	N	SOIC, TSSOP	0.95
TL712	Single, High Speed	1	20	16	0.025	4.75	5.25	5	Push-Pull	N	PDIP, SOIC, SOP	0.83
LM306	Single, Strobed, General Purpose	1	10	100	0.028	15	24	5	Push-Pull	N	PDIP, SOIC	0.77
TLV3201	Single, Dual Push-Pull/Open Drain	1,2	50	25	0.04	2.5	5.5	5	PP/Open-Drain	N	SC70, SOT-23 MSOP, SOIC	0.40
LM211	Single, High Speed, Strobed	1	6	25	0.115	3.5	30	3	Open-Collector/Emitter	Y	PDIP, SOIC	0.20
LM311	Single, High Speed, Strobed, Differential	1	7.5	25	0.115	3.5	30	7.5	Open-Collector/Emitter	N	PDIP, SOIC, SOP, TSSOP	0.18
LM111	Single, Strobed, Differential	1	6	25	0.165	3.5	30	3	Open-Collector/Emitter	Y	CDIP, LCCC	1.57
LMV331	Single, Low Voltage	1	0.12	10	0.2	2.7	5.5	7	Open-Collector	Y	SC-70, SOT-23	0.36
LMV339	Quad, Low Voltage	4	0.075	10	0.2	2.7	5.5	7	Open-Collector	N	SOIC, TSSOP	0.36
LMV393	Dual, Low Voltage	2	0.1	10	0.2	2.7	5.5	7	Open-Collector	Y	SOIC, TSSOP	0.30
TLC352	Ultra-Low Supply Voltage	2, 4	0.15	6	0.2	1.5	18	5	Open-Drain	N	PDIP, SOIC, TSSOP	0.40
TLC372	Fast, Low Power	2, 4	0.15	6	0.2	2	18	5	Open-Drain	Y	PDIP, SOIC, TSSOP	0.33
TLV2352	Low Voltage	2, 4	0.125	6	0.2	2	8	5	Open-Drain	Y	PDIP, SOIC, TSSOP	0.80
LM139	Quad, Differential	4	0.5	6	0.3	2	36	2	Open-Collector	Y	SOIC	0.54
LM193	Dual, Differential	2	0.5	6	0.3	2	36	5	Open-Collector	N	SOIC	0.30
LM239	Quad, Differential	4	0.5	6	0.3	2	30	2	Open-Collector	Y	PDIP, SOIC	0.22
LM2901	Quad, Differential	4	0.625	6	0.3	2	30	3	Open-Collector	Y	PDIP, SOIC, SOP, TSSOP	0.18

*Suggested resale price in U.S. dollars in quantities of 1,000. See www.ti.com/hirel for HiRel options.

New products are listed in bold red. Preview products are listed in bold blue.

Voltage References and Comparators

→ Comparators

Comparators (continued)

Device	Description	Ch.	I _Q Per Ch. (mA) (max)	Output Current (mA) (min)	t _{RESP} Low-to-High (μs)	V _S (V) (min)	V _S (V) (max)	V _{OS} (25°C) (mV) (max)	Output Type	HiRel Avail.	Package(s)	Price*
LM2903	Dual, Differential	2	0.5	6	0.3	2	30	7	Open-Collector	N	PDIP, SOIC, SOP, TSSOP	0.18
LM293	Dual, Differential	2	0.5	6	0.3	2	30	3	Open-Collector	Y	PDIP, SOIC	0.20
LM3302	Quad, General Purpose	4	0.2	6	0.3	2	28	20	Open-Drain/Emitter	N	PDIP, SOIC	0.36
LM339	Quad, Differential	4	0.5	6	0.3	2	30	3	Open-Collector	N	PDIP, SOIC, SOP, SSOP, TSSOP	0.16
LM393	Dual, Differential	2	0.5	6	0.3	2	30	3	Open-Collector	N	PDIP, SOIC, SOP, TSSOP	0.16
TL331	Single, Differential	1	0.7	6	0.3	2	36	5	Open-Collector	Y	SOT-23	0.18
TLC339	Quad, Low Power	4	0.02	6	1	3	16	5	Open-Drain	N	PDIP, SOIC, TSSOP	0.44
TLC3702	Dual and Quad, μPower	2, 4	0.02	4	1.1	3	16	5	Push-Pull	Y	PDIP, SOIC, TSSOP	0.34
TLC393	Low Power, LM393 Replacement	2	0.02	6	1.1	3	16	5	Open-Drain	Y	PDIP, SOIC, SOP, TSSOP	0.37
LP311	Single, Strobed, Low Power	1	0.3	25	1.2	3.5	30	7.5	Open-Drain/Emitter	N	PDIP, SOIC, SOP	0.68
LP2901	Quad, Low Power, General Purpose	4	0.025	30	1.3	5	30	5	Open-Collector	Y	PDIP, SOIC	0.68
LP339	Quad, Low Power, General Purpose	4	0.025	30	1.3	5	30	5	Open-Collector	N	PDIP, SOIC	0.27
TLV3491	Low Voltage, Excellent Speed/Power	1, 2, 4	0.0012	5	6	1.8	5.5	15	Push-Pull	Y	SOT-23, SOIC, TSSOP	0.42
TLV3701	Nanopower, Push-Pull, RRIO	1, 2, 4	0.0008	1.6	36	2.5	16	5	Push-Pull	Y	MSOP, PDIP, SOIC, SOT-23, TSSOP	0.60
TLV3401	Nanopower, Open-Drain, RRIO	1, 2, 4	0.00055	1.6	80	2.5	16	3.6	Open-Drain	N	MSOP, PDIP, SOIC, SOT-23, TSSOP	0.60
Comparator with Integrated Functions												
TLV2702	Sub-μPower, Op Amp and Comparator, RRIO	2, 4	0.0019	0.2	36	2.5	16	5	Push-Pull	N	MSOP, PDIP, SOIC, TSSOP	0.90
TLV2302	Sub-μPower, Op Amp and Comparator, RRIO	2, 4	0.0017	0.2	55	2.5	16	5	Open-Collector	N	MSOP, PDIP, SOIC, TSSOP	0.70
TLV3011	μPower, Comparator with 1.242V Reference	1	0.003	5	6	1.8	5.5	15	Open-Drain	Y	SC-70, SOT-23	0.75
TLV3012	μPower, Comparator with 1.242V Reference	1	0.003	5	6	1.8	5.5	15	Push-Pull	N	SC-70, SOT-23	0.75

*Suggested resale price in U.S. dollars in quantities of 1,000. See www.ti.com/hirel for HiRel options.

New products are listed in bold red.

➔ Analog-to-Digital Converters – Delta-Sigma ADCs

Ultra-Small, Low-Power, 16-Bit Analog-to-Digital Converter with Internal Reference

ADS1113, ADS1114, ADS1115

Get samples and datasheets at: www.ti.com/sc/device/PARTnumber (Replace **PARTnumber** with **ADS1113**, **ADS1114**, **ADS1115**)

Key Features

- Ultra-small QFN package: 2mm x 1.5mm x 0.4mm
- Low current consumption: continuous mode is only 150µA and a single-shot mode is available
- Programmable data rate: 8SPS to 860SPS
- Internal low-drift voltage reference
- Internal oscillator
- Internal PGA: $\frac{2}{3}$, 1, 2, 4, 8, 16
- I²C interface: four pin-selectable addresses
- Four single-ended or two differential inputs (ADS1115)
- Programmable comparator (ADS1114 and ADS1115)
- Wide supply range: 2.0V to 5.5V

Applications

- Portable instrumentation
- Consumer goods
- Battery monitoring
- Temperature measurement
- Factory automation and process controls

The ADS1113, ADS1114 and ADS1115 are precision analog-to-digital converters (ADCs) with 16 bits of resolution offered in an ultra-small, leadless QFN-10 package or MSOP-10 package. The ADS1113/4/5 are designed with precision, power and ease of implementation in mind. The ADS1113/4/5 feature an onboard reference and oscillator. Data are transferred via an I²C-compatible serial interface; four I²C slave addresses can be selected. The ADS1113/4/5 operate from a single power supply ranging from 2.0V to 5.5V.

The ADS1113/4/5 can perform conversions at rates up to 860 samples per second (SPS). An onboard PGA available on the ADS1114 and ADS1115 offers input ranges from the supply to as low as ±256mV, allowing both large and small signals to be measured with high resolution. The ADS1115 also features an input multiplexer (MUX) that provides two differential or four single-ended inputs.

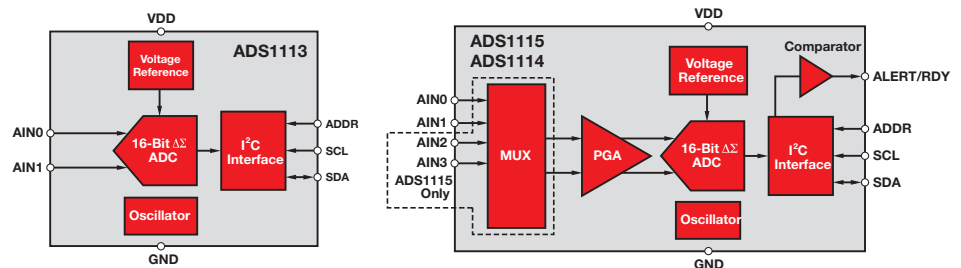

ADS1113, ADS1114, ADS1115 functional block diagram

24-Bit Analog-to-Digital Converters for Temperature and Industrial Measurement

ADS1246, ADS1247, ADS1248

Get samples and datasheets at: www.ti.com/sc/device/ADS1248

Key Features

- Low-noise PGA: 48nV at PGA = 128
- Data output rates up to 2kSPS
- Single-cycle settling for all data rates
- Simultaneous 50/60Hz rejection at 20SPS
- 4 diff/7 single-ended inputs (ADS1248)
- 2 diff/3 single-ended inputs (ADS1247)
- Matched current-source DACs
- Very low drift internal voltage reference: 10ppm/°C (max)
- Sensor burnout detection
- 4/8 general-purpose I/Os (ADS1247/8)
- Internal temperature sensor
- Power supply and V_{REF} monitoring

Applications

- Temperature measurement
 - RTDs, thermocouples and thermistors
- Pressure measurement
- Industrial process control

The ADS1246, ADS1247 and ADS1248 are highly integrated, precision, 24-bit analog-to-digital converters (ADCs). The ADS1246/7/8 feature an onboard, low-noise programmable gain amplifier (PGA), a precision delta-sigma (ΔΣ) ADC with a single-cycle settling digital filter and an internal oscillator. The ADS1247 and ADS1248 also provide a built-in, low-drift voltage reference with 10mA output capacity and two matched programmable current digital-to-analog converters (DACs). The ADS1246/7/8 provide a complete front-end solution for temperature sensor applications including burning thermocouples, thermistors and RTDs.

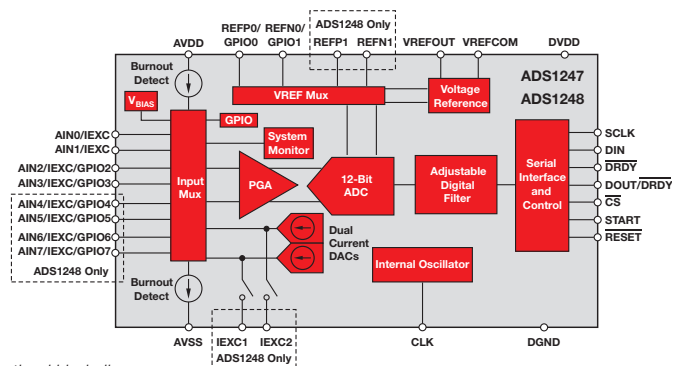

ADS1247/1248 functional block diagram

➔ Analog-to-Digital Converters – Delta-Sigma ADCs

Industrial, 14kSPS, 24-Bit Analog-to-Digital Converter with Low-Drift Reference

ADS1259

Get samples and datasheets at: www.ti.com/sc/device/ADS1259

Key Features

- High performance
 - INL: 0.4ppm
 - Reference drift: 2ppm/°C
 - Gain drift: 0.5ppm/°C
 - Offset drift: 0.05µV/°C
 - Noise: 0.7µV_{RMS} at 60SPS
- 24-bits, no missing codes
- Output data rates from 10SPS to 14kSPS
- Simultaneous 50/60Hz rejection at 10SPS
- Single-cycle settling
- Internal oscillator

Applications

- Industrial process control
- Scientific instrumentation
- Test and measurement

The ADS1259 is a high-linearity, low-drift, 24-bit analog-to-digital converter (ADC) designed for the needs of industrial process control, precision instrumentation and other exacting applications. Combined with a signal amplifier (such as the PGA280-p.26), a high-resolution, high-accuracy measurement system is formed that is capable of digitizing a wide range of signals.

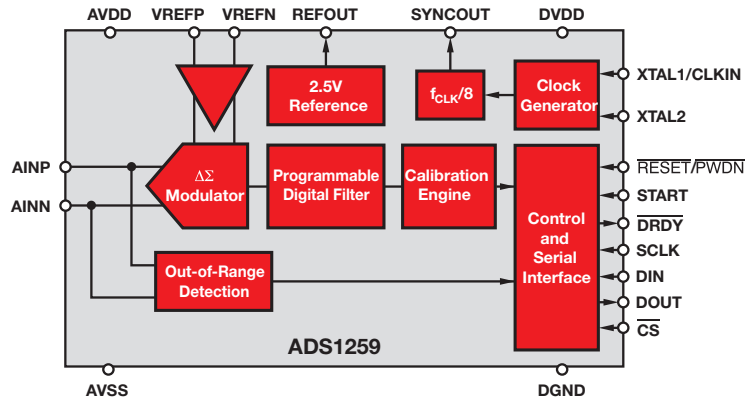

ADS1259 functional block diagram

Ultra-Small, Low-Power, SPI™-Compatible, 16-Bit Analog-to-Digital Converter

ADS1118



Get samples and datasheets at: www.ti.com/sc/device/ADS1118

Key Features

- Ultra-small QFN package: 2mm × 1.5mm × 0.4mm
- Wide supply range: 2.0V to 5.5V
- Low current consumption:
 - Continuous mode: 150mA
 - Single-shot mode: auto shutdown
- Programmable data rate: 8SPS to 860SPS
- Internal low-drift
- Voltage reference
- Internal oscillator
- Internal PGA
- Four single-ended or two diff inputs
- Internal temperature sensor

Applications

- Portable instrumentation
- Consumer goods
- Battery monitoring
- Temperature measurement
- Factory automation/process controls

The ADS1118 is a precision analog-to-digital converter (ADC) with 16 bits of resolution offered in an ultra-small, leadless QFN-10 package or an MSOP-10 package. The ADS1118 is designed with precision, power, and ease of implementation in mind. It features an onboard reference and oscillator. Data is transferred via an SPI™-compatible serial interface. The ADS1118 operates from a single power supply ranging from 2V to 5.5V.

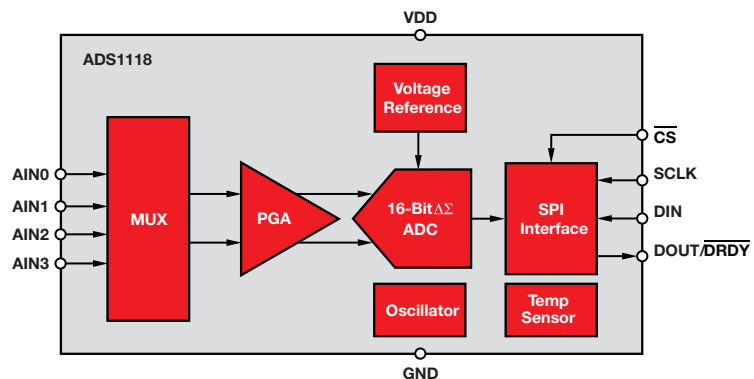

ADS1118 functional block diagram

➔ Analog-to-Digital Converters – Delta-Sigma ADCs

Delta-Sigma ($\Delta\Sigma$) ADCs

Device	Res. (Bits)	Sample Rate (kSPS)	Number of Input Channels	Interface	Input Voltage (V)	V _{REF}	Linearity (%)	Power (mW)	HiRel Avail.	Package(s)	Price*
ADS1113	16	0.86	1 SE/1 Diff	Serial, I ² C	±2.048	Int	0.0015	0.3	N	MSOP-10, x2QFN-10	1.85
ADS1114	16	0.86	1 SE/1 Diff	Serial, I ² C	PGA (2/3-16), V _{DD}	Int	0.0015	0.3	N	MSOP-10, x2QFN-10	2.00
ADS1115	16	0.86	4 SE/2 Diff	Serial, I ² C	PGA (2/3-16), V _{DD}	Int	0.0015	0.3	N	MSOP-10, x2QFN-10	2.25
ADS1013	12	3.3	1 SE/1 Diff	Serial, I ² C	±2.048	Int	0.0244	0.3	N	MSOP-10, x2QFN-10	0.90
ADS1014	12	3.3	1 SE/1 Diff	Serial, I ² C	PGA (2/3-16), V _{DD}	Int	0.0244	0.3	N	MSOP-10, x2QFN-10	1.00
ADS1015	12	3.3	4 SE/2 Diff	Serial, I ² C	PGA (2/3-16), V _{DD}	Int	0.0244	0.3	Y	MSOP-10, x2QFN-10	1.10
ADS1118	16	0.86	4 SE/2 Diff	SPI™	PGA (2/3-16), V _{DD}	Int	0.0015	0.3	N	MSOP-10, x2QFN-10	2.25
ADS1018	12	3.3	4 SE/2 Diff	SPI	PGA (2/3-16), V _{DD}	Int	0.0244	0.3	N	MSOP-10, x2QFN-10	1.10
ADS1146	16	2	1 Diff	Serial, SPI	PGA (1-128), ±2.5	Ext	0.0015	1.4	N	TSSOP-16	2.70
ADS1246	24	2	1 Diff	Serial, SPI	PGA (1-128), ±2.5	Ext	0.0003	2.56	N	TSSOP-16	3.45
ADS1259	24	14	1	SPI	5	Int/Ext	0.00004	13	N	TSSOP-20	5.60
ADS1672	24	625	1	Serial	5	Ext	0.0003	350	N	TQFP-64	11.75
ADS1158	16	125	16 SE/8 Diff	Serial, SPI	+5, ±2.5	Ext	0.0045	42	N	QFN-40	5.95
ADS1258	24	125	16 SE/8 Diff	Serial, SPI	5, ±2.5	Ext	0.0015	40	Y	QFN-48	7.95
ADS1174	16	52	4	Serial, SPI w/FS	2.5	Ext	0.0045	135	N	HTQFP-64	9.95
ADS1178	16	52	8	Serial, SPI w/FS	2.5	Ext	0.0045	245	N	HTQFP-64	15.95
ADS1274	24	128	4 Diff Simultaneous	Serial, SPI w/FSYNC	2.5	Ext	0.001	30-300	N	TQFP-64	13.95
ADS1278	24	128	8 Diff Simultaneous	Serial, SPI w/FSYNC	2.5	Ext	0.001	60-600	Y	TQFP-64	23.95
ADS1271	24	105	1 Diff	Serial, SPI w/FSYNC	2.5	Ext	0.0015	35-100	N	TSSOP-16	5.90
ADS1147	16	2	3 SE/2 Diff	Serial, SPI	PGA (1-128), ±2.5	Int/Ext	0.0015	1.4	N	TSSOP-20	3.45
ADS1148	16	2	7 SE/4 Diff	Serial, SPI	PGA (1-128), ±2.5	Int/Ext	0.0015	1.4	N	TSSOP-28	3.95
ADS1247	24	2	3 SE/2 Diff	Serial, SPI	3 to +5, ±2.5	Ext	0.0003	2.56	N	TSSOP-20	4.45
ADS1248	24	2	7 SE/4 Diff	Serial, SPI	3 to +5, ±2.5	Int/Ext	0.0003	2.56	N	TSSOP-28	4.95
ADS1252	24	41	1 SE/1 Diff	Serial	5	Ext	0.0015	40	N	SOIC-8	6.45
ADS1256	24	30	8 SE/4 Diff	Serial, SPI	PGA (1-64), 5	Ext	0.001	35	N	SSOP-28	6.95
ADS1255	24	30	2 SE/1 Diff	Serial, SPI	PGA (1-64), 5	Ext	0.001	35	N	SSOP-20	6.50
ADS1253	24	20	4 SE/4 Diff	Serial	5	Ext	0.0015	7.5	N	SSOP-16	6.70
ADS1254	24	20	4 SE/4 Diff	Serial	5	Ext	0.0015	4	Y	SSOP-20	6.70
ADS1251	24	20	1 SE/1 Diff	Serial	5	Ext	0.0015	7.5	N	SOIC-8	5.60
ADS1216	24	0.78	8 SE/4 Diff	Serial, SPI	PGA (1-128), 2.5	Int/Ext	0.0015	0.6	N	TQFP-48	5.00
ADS1217	24	0.78	8 SE/4 Diff	Serial, SPI	PGA (1-128), 5	Int/Ext	0.0012	0.8	N	TQFP-48	5.00
ADS1218	24	0.78	8 SE/4 Diff	Serial, SPI	PGA (1-128), 2.5	Int/Ext	0.0015	0.8	N	TQFP-48	5.50
ADS1224	24	0.24	4 SE/4 Diff	Serial	5	Ext	0.0015	0.5	N	TSSOP-20	3.25
ADS1222	24	0.24	2 SE/2 Diff	Serial	5	Ext	0.0015	0.5	N	TSSOP-14	2.95
ADS1234	24	0.08	4 SE/4 Diff	Serial	PGA (1-128), 2.5	Ext	0.0015	3	N	TSSOP-28	4.50
ADS1232	24	0.08	2 SE/2 Diff	Serial	PGA (1-128), 2.5	Ext	0.0015	3	N	TSSOP-24	3.90
ADS1226	24	0.08	2 Diff	Serial	5	Ext	0.0015	0.5	N	QFN-16	2.95
ADS1225	24	0.08	1 Diff	Serial	5	Ext	0.0015	0.5	N	QFN-16	2.75
ADS1241	24	0.015	8 SE/4 Diff	Serial, SPI	PGA (1-128), 2.5	Ext	0.0015	0.5	N	SSOP-28	4.20
ADS1243	24	0.015	8 SE/4 Diff	Serial, SPI	PGA (1-128), 2.5	Ext	0.0015	0.6	N	TSSOP-20	3.95
ADS1240	24	0.015	4 SE/2 Diff	Serial, SPI	PGA (1-128), 2.5	Ext	0.0015	0.6	N	SSOP-24	3.80
ADS1242	24	0.015	4 SE/2 Diff	Serial, SPI	PGA (1-128), 2.5	Ext	0.0015	0.6	N	TSSOP-16	3.60
ADS1244	24	0.015	1 SE/1 Diff	Serial	5	Ext	0.0008	0.3	N	MSOP-10	2.95

*Suggested resale price in U.S. dollars in quantities of 1,000. See www.ti.com/hirel for HiRel options.

New products are listed in **bold red**. Preview products are listed in **bold blue**.

➔ Analog-to-Digital Converters – Delta-Sigma ADCs

Delta-Sigma ($\Delta\Sigma$) ADCs (continued)

Device	Res. (Bits)	Sample Rate (kSPS)	Number of Input Channels	Interface	Input Voltage (V)	V _{REF}	Linearity (%)	Power (mW)	HiRel Avail.	Package(s)	Price*
ADS1245	24	0.015	1 SE/1 Diff	Serial	2.5	Ext	0.0015	0.5	N	MSOP-10	3.10
ADS1250	20	25	1 SE/1 Diff	Serial, SPI	PGA (1-8), 4	Ext	0.003	75	N	SOIC-16	6.95
ADS1131	18	0.08	1 SE/1 Diff	Serial	0.02	Ext	0.0008	1.6	N	TSSOP-16	1.95
ADS1230	20	0.08	1 SE/1 Diff	Serial	0.02	Ext	0.003	3	N	TSSOP-16	2.50
ADS1231	20	0.08	1 SE/1 Diff	Serial	0.02	Ext	0.003	1.6	N	TSSOP-16	2.10
ADS1112	16	0.24	3 SE/2 Diff	Serial, I ² C	PGA (1-8), 2.048	Int	0.01	0.7	N	MSOP-10, SON-10	2.65
ADS1110	16	0.24	1 SE/1 Diff	Serial, I ² C	PGA (1-8), 2.048	Int	0.01	0.7	N	SOT23-6	1.95
ADS1100	16	0.128	1 SE/1 Diff	Serial, I ² C	PGA (1-8), V _{DD}	Ext	0.0125	0.3	N	SOT23-6	1.80
ADS1000	12	0.128	1 SE/1 Diff	Serial, I ² C	PGA (1-8), V _{DD}	Ext	0.0125	0.3	Y	SOT23-6	0.65
ADS1281	31	4	1	Serial, I ² C	5	Ext	0.00006	12	N	TSSOP-24	28.95
ADS1282	31	4	1	Serial, I ² C	PGA (1-64), 5	Ext	0.00006	27	Y	TSSOP-28	36.95

Delta-Sigma ($\Delta\Sigma$) ADCs

Device	Res. (Bits)	Sample Rate (kSPS)	Number of Input Channels	Interface	Input Full-Scale (C)	V _{REF}	Linearity (%)	Power (mW)	HiRel Avail.	Package	Price*
Delta-Sigma ($\Delta\Sigma$) ADCs for Measuring Low-Level Currents (Photodiodes)											
DDC264	20	3	64	Serial	12.5-150pC	Ext	0.05	192	N	BGA-100	—
DDC232	20	3	32	Serial	12-350pC	Ext	0.025	224-320	N	BGA-64	70.00
DDC316	16	100	16	Serial	3pC-12pC	Ext	0.025	440	N	BGA-64	48.25
DDC118	20	3	8	Serial	12-350pC	Ext	0.025	110	N	QFN-48	32.00

Wide Bandwidth Delta-Sigma ($\Delta\Sigma$) ADCs

Device	Res. (Bits)	Sample-Rate (kSPS)	Number of Input Channels	Interface	Signal Bandwidth (kHz)	SNR (dB)	THD (dB)	Power (mW)	HiRel Avail.	Package	Price*
ADS1672	24	625	1 Diff	SPI/LVDS	305	105	-115	350	N	TQFP-64	11.75
ADS1626	18	1250	1 Diff	P18 w/FIFO	615	93	-101	515	N	TQFP-64	15.50
ADS1625	18	1250	1 Diff	P18	615	93	-101	515	N	TQFP-64	14.95
ADS1601	16	1250	1 Diff	Serial	615	92	-103	350	N	TQFP-48	9.95
ADS1602	16	2500	1 Diff	Serial	1230	91	-103	530	N	TQFP-48	12.50
ADS1675	24	4000	1 Diff	Serial/LVDS	1700	107	-107	510	N	TQFP-64	17.95
ADS1606	16	5000	1 Diff	P16 w/FIFO	2450	88	-99	570	N	TQFP-64	15.50
ADS1605	16	5000	1 Diff	P16	2450	88	-99	570	N	TQFP-64	14.95
ADS1610	16	10MSPS	1 Diff	P16	4900	86	-94	960	N	TQFP-64	19.95

*Suggested resale price in U.S. dollars in quantities of 1,000. See www.ti.com/hirel for HiRel options.

New products are listed in bold red. Preview products are listed in bold blue.

➔ Analog-to-Digital Converters – SAR ADCs

12-Bit, 4-Channel MUX Input, microPower SAR ADC with Intelligent System Power Control ADS7924

Get samples, datasheets and EVMs at: www.ti.com/sc/device/ADS7924

Key Features

- Micropower monitoring:
 - 4-ch scanning 5µW/10ms:
 - <1µA of power-down current
- Programmable interrupt pin controls shutdown/wakeup
- Auto power-down control PWRCON pin allows shutdown of external op amp
- Wide supply range:
 - Analog supply: 2.2V to 5.5V
 - Digital supply: 1.65V to 5.5V
- Small footprint: 3mm x 3mm QFN

Applications

- Portable and battery-powered systems
 - Medical
 - Remote sensor signal monitoring
- Energy harvesting

The ADS7924 features a low-power ADC core, support for low-supply operation and a flexible measurement sequencer that essentially eliminates power consumption between conversions. Additionally, through the use of dedicated data registers and onboard programmable digital threshold comparators, each input can trigger an alarm condition, resulting in an interrupt generated to the host microcontroller. The combination of data buffering, programmable threshold comparisons and alarm interrupts minimize the time and power expended by the host microcontroller dedicated to supervising the ADS7924. The result is a complete monitoring system for power-critical applications such as battery-powered equipment and energy-harvesting systems.

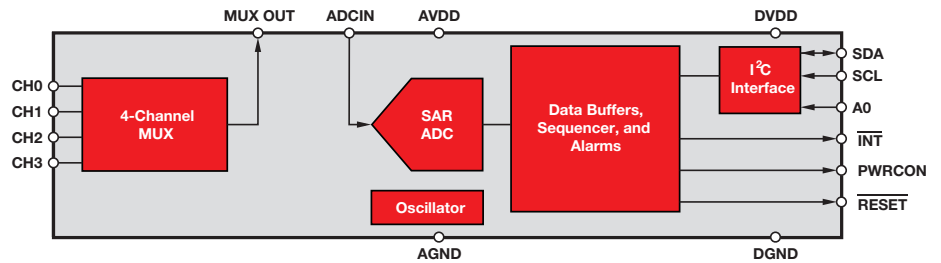

ADS7924 functional block diagram

12-/10-/8-Bit, 2-Ch, 2MSPS, Single-Ended, Psuedo-Differential Input, microPower SAR ADCs ADS7947, ADS7948, ADS7949

Get samples, datasheets and EVMs at: www.ti.com/sc/device/PARTnumber (Replace **PARTnumber** with **ADS7947**, **ADS7948**, **ADS7949**)

Key Features

- ±1 LSB offset and gain drift (max)
- 72dB SNR (12-bit, min)
- True 12-bit performance
- Dedicated power-down mode enable pin
- Auto power-down scales to 7.7µW/kSPS at 3V
- Pseudo-differential inputs
- 2.8V to 5.25V supply range
- 2.5V to 5.25V reference range
- 1.8V to 5V logic family compatible
- SPI interface
- 3mm x 3mm QFN package

Applications

- Optical networking
- Instrumentation and control systems
- X-Y positioning
- Portable systems
- Battery monitoring
- High speed data acquisition

The ADS7947/8/9 dual-channel, low-power, 8-/10-/12-bit, 2-MSPS ADCs offer outstanding performance. The wide reference and supply range enables these devices to be used in both low-cost 5V applications in addition to low-power 3.3V applications. As a result of the high-precision gain and offset stability of the devices, there is no need to calibrate gain and offset over temperature, which reduces system complexity and development time. Lastly, the psuedo-differential inputs reduce the need for common mode DC signal conditioning circuitry, which lowers system cost and complexity and increases system reliability.

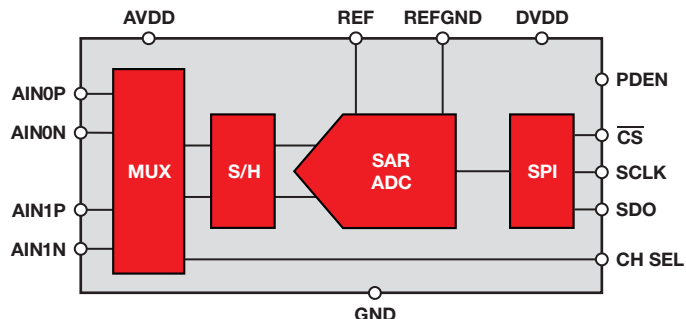

ADS7947/8/9 functional block diagram

➔ Analog-to-Digital Converters – SAR ADCs

Dual, 1MSPS, 16-/14-/12-Bit, Simultaneous Sampling Analog-to-Digital Converter ADS8363, ADS7263, ADS7223

NEW

Get samples, datasheets and EVMs at: www.ti.com/sc/device/PARTnumber (Replace **PARTnumber** with **ADS8363, ADS7263, ADS7223**)

Key Features

- Dual, 4-ch pseudo or 2-ch fully differential configurable inputs
- Dual 2.5V programmable reference
- Dual ADCs with NMC
- 93dB SNR (ADS8363)
- 4 deep per-channel FIFO
- Auto-scan mode
- Extended temp range: -40 to 125°C
- Compact packaging: QFN-32

Applications

- Motor control current and position measurement
- Power quality measurement
- Three-phase power control
- Programmable logic controllers
- Industrial automation
- Protection relays

The ADS8363 is a dual, 16-bit, 1MSPS ADC with eight pseudo or four fully-differential input channels grouped into two pairs for simultaneous signal acquisition. The analog inputs are maintained differentially to the input of the ADC. The input multiplexer can be used in either pseudo-differential mode, supporting up to four channels per ADC (4x2), or in fully-differential mode supporting up to two inputs per ADC (2x2). The ADS7263 is a 14-bit version while the ADS7223 is a 12-bit version of the ADS8363. The devices offer two programmable reference outputs, flexible supply voltage ranges, a programmable auto-sequencer, data storage of up to four conversion results per channel, and several power-down features.

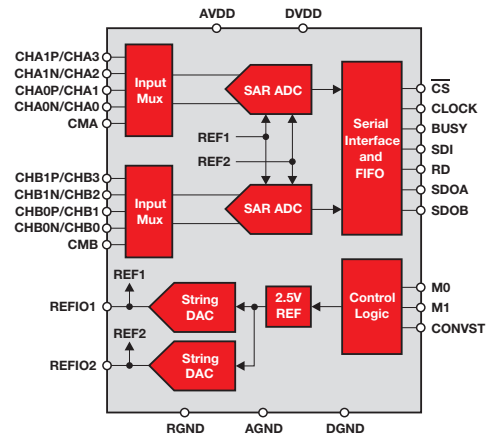

Functional block diagram

2.2V to 5.5V, Low-Power, 12-Bit, 100kSPS, 8-Channel DAS with PGA and SPI™ ADS8201

Get samples, datasheets and EVMs at: www.ti.com/sc/device/ADS8201

Key Features

- Low-power, flexible supply range:
 - 1.32mW (+VA = 2.2V, +VD = 2.2V)
 - 4.5mW (+VA = 5V, +VD = 5V)
- Excellent DC performance:
 - ±0.5 LSB typ, ±1.5 LSB (max) INL
 - ±0.5 LSB typ, ±1.0 LSB (max) DNL
 - ±6 LSB offset error at +VA = 5V
 - ±0.1% FS gain error at +VA = 5V
- Flexible analog inputs:
 - High-performance PGA (Gain = 1/2/4/8) with breakout
 - Eight single-ended/four differential
 - True differential input
 - Differential/unipolar input range (0 to V_{REF})
- Separate 2.2V to 5.5V I/O supply
- 24-pin 4x4 QFN package

Applications

- Portable communications
- Transducer interfaces
- Portable medical instruments
- Data acquisition systems
- GPS chipsets

The ADS8201 is a low-power, complete on-chip data acquisition system optimized for portable applications that require direct connections, wide dynamic range, and automatic operation with very low power consumption. The device includes a 12-bit, capacitor-based, successive approximation register (SAR) analog-to-digital converter (ADC); a high-performance, continuous-time programmable gain amplifier (PGA); and a fully automatic scan, 8-to-1 multiplexer (mux) with breakout to allow for system design flexibility.

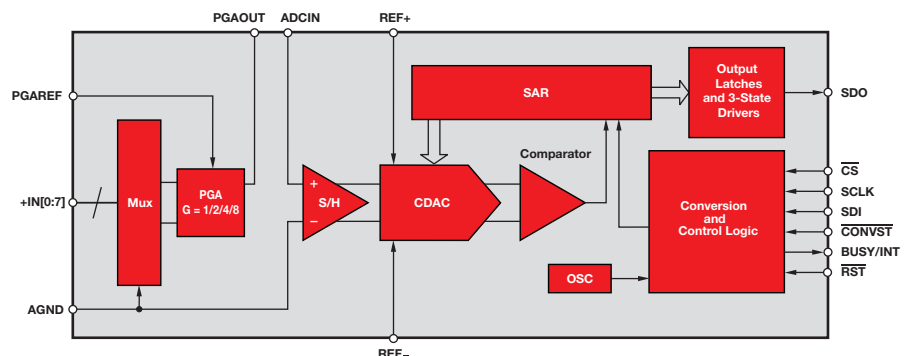

ADS8201 functional block diagram

ADCs by Architecture

→ Analog-to-Digital Converters – SAR ADCs

Unipolar Input SAR ADCs

Device	Res. (Bits)	Sample-Rate (kSPS)	Power (mW)	Number of Input Channels	Interface	Input Voltage (V)	V _{REF}	Linearity (%)	NMC	SINAD (dB)	HiRes! Avail.	Package(s)	Price*
18-Bit SAR ADCs													
ADS8484	18	1,250	220	1 Diff	P8/P16/P18	±V _{REF} (4.1V) at V _{REF} /2	Int/Ext	0.0011	18	98	N	7x7 QFN, TQFP-48	23.40
ADS8486	18	1,250	10	1 Diff	Serial, SPI™	V _{REF} , ±V _{REF} at V _{REF}	Ext	0.0006	18	98.5	N	VSSOP-10, SON-10	9.99
ADS8284	18	1,000	270	4 Diff	P8/P16/P18	±V _{REF} (4.1V) at V _{REF} /2	Int/Ext	0.00095	18	TBD	N	8x8 QFN	22.00
ADS8481	18	1,000	220	1 SE, 1 PDiff	P8/P16/P18	V _{REF} (4.1)	Int/Ext	0.0013	18	92	N	7x7 QFN, TQFP-48	19.80
ADS8482	18	1,000	220	1 Diff	P8/P16/P18	±V _{REF} (4.1V) at V _{REF} /2	Int/Ext	0.0011	18	98	N	7x7 QFN, TQFP-48	20.25
ADS8380	18	600	110	1 SE, 1 PDiff	Serial, SPI	V _{REF}	Int/Ext	0.0015	18	90	N	6x6 QFN-28	16.50
ADS8382	18	600	110	1 Diff	Serial, SPI	±V _{REF} (4.1V) at V _{REF} /2	Int/Ext	0.0012	18	95	N	6x6 QFN-28	16.95
ADS8381	18	580	115	1 SE, 1 PDiff	P8/P16/P18	V _{REF} (4.1)	Ext	0.0019	18	88	N	TQFP-48	16.65
ADS8383	18	500	110	1 SE, 1 PDiff	P8/P16/P18	V _{REF} (4.1)	Ext	0.0026	18	85	N	TQFP-48	15.75
16-Bit SAR ADCs													
ADS8422	16	4,000	160	1 Diff	P8/P16	±V _{REF} (4.1V) at V _{REF} /2	Int/Ext	0.0023	16	92.5	N	7x7 QFN, TQFP-48	23.95
ADS8410	16	2,000	290	1 SE, 1 PDiff	Serial, LVDS	V _{REF} (4.1)	Int/Ext	0.0038	16	87.5	N	7x7 QFN-48	23.00
ADS8413	16	2,000	290	1 Diff	Serial, LVDS	±V _{REF} (4.1V) at V _{REF} /2	Int/Ext	0.0038	16	92	N	7x7 QFN-48	24.05
ADS8411	16	2,000	175	1 SE, 1 PDiff	P8/P16	V _{REF}	Int	0.0038	16	85	N	TQFP-48	22.00
ADS8412	16	2,000	175	1 Diff	P8/P16	±V _{REF} (4.1V) at V _{REF} /2	Int	0.0038	16	88	N	TQFP-48	23.05
ADS8408	16	1,350	9	1 Diff	Serial, SPI	V _{REF} , ±V _{REF} at V _{REF}	Ext	0.0006	16	—	N	VSSOP-10, SON-10	8.99
ADS8407	16	1,350	9	1 SE	Serial, SPI	V _{REF}	Ext	0.0019	16	—	N	VSSOP-10, SON-10	7.99
ADS8405	16	1,250	155	1 SE, 1 PDiff	P8/P16	V _{REF}	Int/Ext	0.003	16	85	N	TQFP-48	14.10
ADS8406	16	1,250	155	1 Diff	P8/P16	±V _{REF} (4.1V) at V _{REF} /2	Int/Ext	0.003	16	90	N	TQFP-48	14.70
ADS8254	16	1,000	270	4 Diff	P8/P16	±V _{REF} (4.2V) at V _{REF} /2	Int/Ext	0.0011	16	TBD	N	8x8 QFN	18.50
ADS8472	16	1,000	110	1 Diff	Serial, SPI	±V _{REF} (4.2V) at V _{REF} /2	Int/Ext	0.00098	16	94	N	6x6 QFN-28	13.00
ADS8471	16	1,000	110	1 SE, 1 PDiff	Serial, SPI	V _{REF}	Int/Ext	0.0015	16	90	N	6x6 QFN-28	12.50
ADS8363	16	1,000	79	4x2/2x2	Serial, SPI	±V _{REF} at ±V _{REF}	Dual Int/Ext	0.009	16	92	N	QFN-32	9.28
ADS8329	16	1,000	20	1 SE, 1 PDiff	Serial, SPI	V _{REF} (4.2V at 5V, 2.5V at 2.7V Supply)	Ext	0.0026	16	92	N	TSSOP-16	11.25
ADS8330	16	1,000	15.5	2 SE, 2 PDiff	Serial, SPI	V _{REF} (5V at 5V, 2.5V at 2.7V Supply)	Ext	0.0026	16	92	N	TSSOP-16, 4x4 QFN-16	11.85
ADS8555	16	800	160	1 x 6 Diff	Serial, SPI/P16/P8	±2x/±4xV _{REF} (±1V to ±12V)	Int/Ext	0.0046	16	90	N	LQFP-64, 9x9 QFN-64	16.00
ADS8556	16	800	160	1 x 6 Diff	Serial, SPI/P16/P8	±2x/±4xV _{REF} (±1V to ±12V)	Int/Ext	0.0046	16	90	N	LQFP-64, 9x9 QFN-64	16.00

*Suggested resale price in U.S. dollars in quantities of 1,000.

New products are listed in bold red. Preview products are listed in bold blue.

ADCs by Architecture

➔ Analog-to-Digital Converters – SAR ADCs

Unipolar Input SAR ADCs (16-Bit) (continued)

Device	Res. (Bits)	Sample-Rate (kSPS)	Power (mW)	Number of Input Channels	Interface	Input Voltage (V)	V _{REF}	Linearity (%)	NMC	SINAD (dB)	HiRel Avail.	Package(s)	Price*
ADS8371	16	750	130	1 SE, 1 PDiff	P8/P16	V _{REF}	Ext	0.0022	16	87.6	N	TQFP-48	12.00
ADS8370	16	600	110	1 SE, 1 PDiff	Serial, SPI	V _{REF}	Int/Ext	0.0015	16	90	N	6x6 QFN-28	12.50
ADS8372	16	600	110	1 Diff	Serial, SPI	±V _{REF} (4.2V) at V _{REF} /2	Int/Ext	0.0011	16	93.5	N	6x6 QFN-28	13.00
ADS8361	16	500	150	2 x 2 Diff	Serial, SPI	±2.5V at +2.5	Int/Ext	0.00375	14	83	N	SSOP-24	8.75
ADS8322	16	500	85	1 PDiff	P8/P16	5	Int/Ext	0.009	15	83	N	TQFP-32	7.10
ADS8323	16	500	85	1 Diff	P8/P16	±2.5V at 2.5	Int/Ext	0.009	15	83	N	TQFP-32	7.10
ADS8318	16	500	18	1 Diff	Serial, SPI	±V _{REF} (4.2V) at V _{REF} /2	Ext	0.0015	16	96	N	MSOP-10	9.00
ADS8319	16	500	18	1 SE, 1 PDiff	Serial, SPI	V _{REF} (4.1)	Ext	0.0023	16	93.8	N	MSOP-10	8.00
ADS8332	16	500	10.6	8 SE, 8 PDiff	Serial, SPI	V _{REF} (2.5)	Int/Ext	0.0031	16	87.5	N	4x4 QFN-24, TSSOP-24	15.00
ADS8331	16	500	10.6	4 SE, 4 PDiff	Serial, SPI	V _{REF} (2.5)	Int/Ext	0.0031	16	87.5	N	4x4 QFN-24, TSSOP-24	13.50
ADS8328	16	500	10.6	2 SE, 2 PDiff	Serial, SPI	V _{REF} (5V at 5V, 2.5V at 2.7V Supply)	Ext	0.00305	16	88.5	N	TSSOP-16, 4x4 QFN-16	9.30
ADS8327	16	500	10.6	2 SE	Serial, SPI	V _{REF} (4.2V at 5V, 2.5V at 2.7V Supply)	Ext	0.00305	16	88.5	N	TSSOP-16	9.30
ADS8364	16	250	413	1 x 6 Diff	P16	±2.5V at +2.5	Int/Ext	0.009	14	82.5	N	TQFP-64	18.10
ADS8342	16	250	200	8 SE	P8/P16	±2.5	Ext	0.006	16	85	N	TQFP-48	11.30
ADS8365	16	250	190	1 x 6 Diff	P16	±2.5V at +2.5	Int/Ext	0.006	14	87	N	TQFP-64	16.25
ADS8317	16	250	6	1 Diff	Serial, SPI	±V _{REF} at V _{REF}	Ext	0.0022	16	89.5	N	VSSOP-8, QFN-8	5.90
ADS8326	16	250	6	1 SE, 1 PDiff	Serial, SPI	V _{REF}	Ext	0.0022	16	91	N	VSSOP-8, QFN-8	5.90
TLC4541	16	200	17.5	1 SE	Serial, SPI	V _{REF}	Ext	0.0038	16	84.5	N	SOIC-8, VSSOP-8	6.85
TLC4545	16	200	17.5	1 PDiff	Serial, SPI	V _{REF}	Ext	0.0038	16	84.5	N	SOIC-8, VSSOP-8	6.85
ADS8321	16	100	5.5	1 Diff	Serial, SPI	±V _{REF} at +V _{REF}	Ext	0.012	15	84	N	VSSOP-8	5.15
ADS8344	16	100	3.6	8 SE/4 Diff	Serial, SPI	V _{REF}	Ext	0.006	15	86	N	SSOP-20	8.00
ADS8345	16	100	3.6	8 SE/4 Diff	Serial, SPI	±V _{REF} at V _{REF}	Ext	0.006	15	85	N	SSOP-20	8.00
ADS8341	16	100	3.6	4 SE/2 Diff	Serial, SPI	V _{REF}	Ext	0.006	15	86	N	SSOP-16	7.40
ADS8343	16	100	3.6	4 SE/2 Diff	Serial, SPI	±V _{REF} at V _{REF}	Ext	0.006	15	86	N	SSOP-16	7.45
ADS8325	16	100	2.25	1 SE, 1 PDiff	Serial, SPI	V _{REF}	Ext	0.006	16	91	N	VSSOP-8, QFN-8	5.90
ADS8320	16	100	1.95	1 SE, 1 PDiff	Serial, SPI	V _{REF}	Ext	0.012	15	84	N	VSSOP-8	5.15
14-Bit SAR ADCs													
ADS7891	14	3,000	85	1 SE	P8/P14	2.5	Int	0.009	14	78	N	TQFP-48	10.50
ADS7946	14	2,500	10	2 Pdiff	Serial, SPI	V _{REF}	Ext	TBD	14	—	N	3x3 QFN-16	2.05
ADS7945	14	2,500	10	2 Diff	Serial, SPI	V _{REF}	Ext	TBD	14	—	N	3x3 QFN-16	2.15
ADS7890	14	1,250	45	1 SE	Serial, SPI	2.5	Int	0.009	14	77	N	TQFP-48	10.50
ADS7263	14	1,000	79	4x2/2x2	Serial, SPI	±V _{REF} at +V _{REF}	Dual Int/Ext	0.012	14	83	N	QFN-32	6.95
ADS7279	14	1,000	15.5	1 SE	Serial, SPI	V _{REF} (4.2V at 5V, 2.5V at 2.7V Supply)	Ext	0.0061	14	85.7	N	TSSOP-16	4.50

*Suggested resale price in U.S. dollars in quantities of 1,000.

New products are listed in bold red. Preview products are listed in bold blue.

ADCs by Architecture

→ Analog-to-Digital Converters – SAR ADCs

Unipolar Input SAR ADCs (14-Bit) (continued)

Device	Res. (Bits)	Sample-Rate (kSPS)	Power (mW)	Number of Input Channels	Interface	Input Voltage (V)	V _{REF}	Linearity (%)	NMC	SINAD (dB)	HiRel Avail.	Package(s)	Price*
ADS7280	14	1,000	13.7	2 SE	Serial, SPI	V _{REF} (5V at 5V, 2.5V at 2.7V Supply)	Ext	0.0061	14	85.7	N	TSSOP-16	4.50
ADS8557	14	800	160	1 x 6 Diff	Serial, SPI	±2x/±4xV _{REF} (±1V to ±12V)	Int/Ext	0.0061	14	82	N	LQFP-64, 9x9 QFN-64	12.00
TLC3548	14	200	20	8 SE	Serial, SPI	4	Int/Ext	0.006	14	81	N	SOIC-24, TSSOP-24	6.40
TLC3544	14	200	20	4 SE	Serial, SPI	4	Int/Ext	0.006	14	81	N	SOIC-20, TSSOP-20	6.00
TLC3541	14	200	17.5	1 SE	Serial, SPI	V _{REF}	Ext	0.006	14	81.5	N	SOIC-8, VSSOP-8	5.00
TLC3545	14	200	17.5	1 PDiff	Serial, SPI	V _{REF}	Ext	0.006	14	81.5	N	SOIC-8, VSSOP-8	5.00
ADS8324	14	50	2.5	1 Diff	Serial, SPI	±V _{REF} at +V _{REF}	Ext	0.012	14	78	N	VSSOP-8	4.15
ADS7871	14	40	6	8 SE/4 Diff	Serial, SPI	PGA (1, 2, 4, 8, 10, 16, 20)	Int	0.03	13	—	N	SSOP-28	5.00
12-Bit SAR ADCs													
ADS7881	12	4,000	95	1 SE	P8/P12	2.5	Int	0.024	12	71.5	N	7x7 QFN, TQFP-48	7.35
ADS7882	12	3,000	85	1 SE	P8/P12	V _{REF}	Int/Ext	0.122	10	68.5	N	TQFP-48	2.50
ADS7883	12	3,000	15	1 SE	Serial, SPI	V _{DD} (2.7V to 5.5V)	Ext (V _{DD})	0.03	12	72	N	SOT-23-6	2.50
ADS7863	12	2,000	13.5	2 x 2 Diff	Serial, SPI	±2.5 at 2.5	Int/Ext	0.003	12	71	N	SSOP-24, 4x4 QFN-24	4.90
ADS7865	12	2,000	13.5	2 x 2 Diff	P12	±2.5 at 2.5	Int/Ext	0.003	12	71.3	N	TQFP-32	4.90
ADS7947	12	2,000	7	2 PDiff	Serial, SPI	V _{REF}	Ext	0.0073	12	—	N	3x3 QFN-16	1.95
ADS7869	12	1,000	175	12 Diff	Serial, SPI/P12	±2.5 at +2.5	Int/Ext	0.048	11	—	N	TQFP-100	14.60
ADS7223	12	1,000	79	4 x 2/2 x 2	Serial, SPI	±V _{REF} at +V _{REF}	Dual Int/Ext	0.048	12	70	N	QFN-32	4.90
ADS7229	12	1,000	15.5	1 SE	Serial/SPI	V _{REF} (4.2V at 5V, 2.5V at 2.7V Supply)	Ext	0.0122	12	73.7	N	TSSOP-16	2.30
ADS7230	12	1,000	13.7	2 SE	Serial/SPI	V _{REF} (5V at 5V, 2.5V at 2.7V Supply)	Ext	0.0122	12	73.7	N	TSSOP-16	2.50
ADS7953	12	1,000	12.5	16 SE	Serial, SPI	V _{REF} (2.5V)	Ext	0.024	12	71.3	N	TSSOP-38	4.90
ADS7952	12	1,000	12.5	12 SE	Serial, SPI	V _{REF} (2.5V)	Ext	0.024	12	71.3	N	TSSOP-38	4.10
ADS7951	12	1,000	12.5	8 SE	Serial, SPI	V _{REF} (2.5V)	Ext	0.024	12	71.3	N	TSSOP-30	3.30
ADS7950	12	1,000	12.5	4 SE	Serial, SPI	V _{REF} (2.5V)	Ext	0.024	12	71.3	N	TSSOP-30	2.50
ADS7886	12	1,000	7.5	1 SE	Serial, SPI	V _{DD} (2.35V to 5.25V)	Ext (V _{DD})	0.03	12	71.2	N	SOT-23-6, SC-70	1.70
ADS8558	12	800	160	1 x 6 Diff	Serial, SPI/P12/P8	±2x/±4xV _{REF} (±1V to ±12V)	Int/Ext	0.0121	12	72	N	LQFP-64, 9x9 QFN-64	10.00
ADS7864	12	500	52.5	3 x 2 Diff	P12	±2.5 at +2.5	Int/Ext	0.024	12	71	N	TQFP-48	6.65
ADS7861	12	500	25	2 x 2 Diff	Serial, SPI	±2.5 at +2.5	Int/Ext	0.024	12	70	N	SSOP-24, QFN-32	4.05
ADS7862	12	500	25	2 x 2 Diff	P12	±2.5 at +2.5	Int/Ext	0.024	12	71	N	TQFP-32	5.70
ADS7852	12	500	13	8 SE	P12	5	Int/Ext	0.024	12	72	N	TQFP-32	3.40
ADS7818	12	500	11	1 PDiff	Serial, SPI	5	Int	0.024	12	70	N	PDIP-8, VSSOP-8	2.50
ADS7834	12	500	11	1 PDiff	Serial, SPI	2.5	Int	0.024	12	70	N	VSSOP-8	2.45
TLC2552	12	400	15	2 SE	Serial, SPI	V _{REF}	Ext	0.024	12	72	N	SOIC-8, VSSOP-8	3.95

*Suggested resale price in U.S. dollars in quantities of 1,000.

New products are listed in **bold red**.

→ Analog-to-Digital Converters – SAR ADCs

Unipolar Input SAR ADCs (12-Bit) (continued)

Device	Res. (Bits)	Sample-Rate (kSPS)	Power (mW)	Number of Input Channels	Interface	Input Voltage (V)	V _{REF}	Linearity (%)	NMC	SINAD (dB)	HiRel Avail.	Package(s)	Price*
TLC2551	12	400	15	1 SE	Serial, SPI	V _{REF}	Ext	0.024	12	72	N	SOIC-8, VSSOP-8	3.95
TLC2555	12	400	15	1 Diff	Serial, SPI	V _{REF}	Int	0.024	12	72	N	SOIC-8, MSOP-8	3.95
TLC2558	12	400	9.5	8 SE	Serial, SPI	4	Int/Ext	0.024	12	71	N	SOIC-20, TSSOP-20	5.30
TLC2554	12	400	9.5	4 SE	Serial, SPI	4	Int/Ext	0.024	12	71	N	SOIC-16, TSSOP-16	5.30
AMC7823	12	200	100	8 SE I/O DAS	Serial, SPI	V _{REF} (5.0)	Int/Ext	0.024	12	74	N	QFN-40	9.75
TLV2548	12	200	3.3	8 SE	Serial, SPI	+2, 4	Int/Ext	0.024	12	70	Y	SOIC-20, TSSOP-20	4.85
TLV2544	12	200	3.3	4 SE	Serial, SPI	+2, 4	Int/Ext	0.024	12	70	Y	SOIC-16, TSSOP-16	4.20
TLV2542	12	200	2.8	2 SE	Serial, SPI	V _{REF}	Ext	0.024	12	72	N	SOIC-8, VSSOP-8	3.85
TLV2541	12	200	2.8	1 SE	Serial, SPI	V _{REF}	Ext	0.024	12	72	N	SOIC-8, VSSOP-8	3.85
TLV2545	12	200	2.8	1 PDiff	Serial, SPI	+5.5 (V _{REF} = V _{DD})	Ext	0.024	12	72	N	SOIC-8, VSSOP-8	3.85
TLV2553	12	200	2.43	11 SE	Serial, SPI	V _{REF}	Ext	0.024	12	—	Y	SOIC-20, TSSOP-20	3.40
TLV2556	12	200	2.43	11 SE	Serial, SPI	V _{REF}	Int/Ext	0.024	12	—	Y	SOIC-20, TSSOP-20	3.55
ADS7817	12	200	2.3	1 Diff	Serial, SPI	±V _{REF} at +V _{REF}	Ext	0.024	12	71	N	SOIC-8, VSSOP-8	1.95
ADS7816	12	200	1.9	1 PDiff	Serial, SPI	V _{REF}	Ext	0.024	12	72	N	PDIP, SOIC, VSSOP-8	1.95
ADS7844	12	200	0.84	8 SE/4 Diff	Serial, SPI	V _{REF} , ±V _{REF} at V _{REF}	Ext	0.024	12	72	N	SSOP-20	2.90
ADS7841	12	200	0.84	4 SE/2 Diff	Serial, SPI	V _{REF} , ±V _{REF} at V _{REF}	Ext	0.024	12	72	Y	SSOP-16	2.50
ADS7842	12	200	0.84	4 SE	P12	V _{REF}	Ext	0.024	12	72	N	SSOP-28	3.10
ADS7822	12	200	0.6	1 PDiff	Serial, SPI	V _{REF}	Ext	0.018	12	71	Y	PDIP, SOIC, VSSOP-8	1.55
ADS7866	12	200	0.25	1 SE, 1 PDiff	Serial, SPI	V _{DD} (1.2V to 3.6V)	Ext	0.024	12	70	N	SOT-23-6	1.85
ADS7829	12	125	0.6	1 PDiff	Serial, SPI	V _{REF}	Ext	0.018	12	71	N	QFN-8	1.50
AMC7820	12	100	40	8 SE DAS	Serial, SPI	V _{REF} (5.0)	Int/Ext	0.024	12	72 (typ)	N	TQFP-48	3.75
ADS7924	12	100	0.5	4 SE	Serial, I ² C	V _{REF}	Ext	0.122	12	—	N	3x3 QFN-16	1.25
TLC2543	12	66	5	11 SE	Serial, SPI	V _{REF}	Ext	0.024	12	—	Y	CDIP, PDIP, PLCC, SOIC, SSOP-20	4.45
TLV2543	12	66	3.3	11 SE	Serial, SPI	V _{REF}	Ext	0.024	12	—	N	PDIP-20, SOIC-20, SSOP-20	4.45
ADS7870	12	50	4.6	8 SE	Serial, SPI	PGA (1, 2, 4, 8, 10, 16, 20)	Int	0.06	12	72	N	SSOP-28	4.15
ADS7823	12	50	0.75	1 SE	Serial, I ² C	V _{REF}	Ext	0.024	12	71	N	VSSOP-8	2.85
ADS7828	12	50	0.675	8 SE/4 Diff	Serial, I ² C	V _{REF}	Int/Ext	0.024	12	71	Y	TSSOP-16	3.35
ADS1286	12	37	1	1 PDiff	Serial, SPI	V _{REF}	Ext	0.024	12	72	N	PDIP-8, SOIC-8	2.80
10-Bit SAR ADCs													
ADS7884	10	3,000	15	1 SE	Serial, SPI	V _{DD} (2.7V to 5.5V)	Ext (V _{DD})	0.781	10	61.7	N	SOT-23-6	1.60
ADS7948	10	2,000	7	2 PDiff	Serial, SPI	V _{REF}	Ext	0.0146	12	—	N	3x3 QFN-16	1.70
TLV1578	10	1,250	12	8 SE	P/O	V _{REF}	Ext	0.1	10	60	N	TSSOP-32	3.85
TLV1571	10	1,250	12	1 SE	P/O	V _{REF}	Ext	0.1	10	60	N	SOIC-24, TSSOP-24	3.70
TLV1570	10	1,250	9	8 SE	Serial, SPI	2V, V _{REF}	Int/Ext	0.1	10	60	N	SOIC-20, TSSOP-20	3.80
TLV1572	10	1,250	8.1	1 SE	Serial, SPI	V _{REF}	Ext	0.1	10	60	N	SOIC-8	3.30
ADS7887	10	1,250	8	1 SE	Serial, SPI	V _{DD} (2.35V to 5.25V)	Ext (V _{DD})	0.073	10	61	N	SOT-23-6, SC-70	1.50
ADS7957	10	1,000	12.5	16 SE	Serial, SPI	V _{REF} (2.5V)	Ext	0.078	10	60	N	TSSOP-38	3.90
ADS7956	10	1,000	12.5	12 SE	Serial, SPI	V _{REF} (2.5V)	Ext	0.078	10	60	N	TSSOP-38	3.30

*Suggested resale price in U.S. dollars in quantities of 1,000. See www.ti.com/hirel for HiRel options.

New devices are listed in bold red.

➔ Analog-to-Digital Converters – SAR ADCs

Unipolar Input SAR ADCs (10-Bit) (continued)

Device	Res. (Bits)	Sample-Rate (kSPS)	Power (mW)	Number of Input Channels	Interface	Input Voltage (V)	V _{REF}	Linearity (%)	NMC	SINAD (dB)	HiRel Avail.	Package(s)	Price*
ADS7955	10	1,000	12.5	8 SE	Serial, SPI	V _{REF} (2.5V)	Ext	0.078	10	60	N	TSSOP-30	2.70
ADS7954	10	1,000	12.5	4 SE	Serial, SPI	V _{REF} (2.5V)	Ext	0.078	10	60	N	TSSOP-30	2.10
TLC1518	10	400	10	8 SE/7 Diff	Serial, SPI	+5.5 (V _{REF} = V _{DD})	Int/Ext	0.012	10	60	N	SOIC-20, TSSOP-20	3.45
TLC1514	10	400	10	4 SE/3 Diff	Serial, SPI	+5.5 (V _{REF} = V _{DD})	Int/Ext	0.012	10	60	N	SOIC-16, TSSOP-16	2.90
TLV1508	10	200	3.3	8 SE	Serial, SPI	+2, 4	Int/Ext	0.05	10	60	N	SOIC-20, TSSOP-20	3.15
TLV1504	10	200	3.3	4 SE	Serial, SPI	+2, 4	Int/Ext	0.05	10	60	N	SOIC-16, TSSOP-16	2.65
ADS7826	10	200	0.6	1 PDiff	Serial, SPI	V _{REF}	Ext	0.0048	10	62	N	QFN-8	1.25
ADS7867	10	200	0.25	1SE, 1 PDiff	Serial, SPI	V _{DD} (1.2V to 3.6V)	Ext	0.05	10	61	N	SOT-23-6	1.40
TLC1550	10	164	10	1 SE	P10	V _{REF}	Ext	0.05	10	—	Y	PLCC-28, SOIC-24	3.90
TLC1551	10	164	10	1 SE	P10	V _{REF}	Ext	0.1	10	—	N	PLCC-28, SOIC-24	3.35
TLV1548	10	85	1.05	8 SE	Serial, SPI	V _{REF}	Ext	0.1	10	—	Y	CDIP, LCCC, SSOP-20	2.30
TLV1544	10	85	1.05	4 SE	Serial, SPI	V _{REF}	Ext	0.1	10	—	N	SOIC-16, TSSOP-16	1.95
TLC1542	10	38	4	11 SE	Serial, SPI	V _{REF}	Ext	0.05	10	—	Y	CDIP, LCCC, PDIP, PLCC, SOIC-20	2.50
TLC1543	10	38	4	11 SE	Serial, SPI	V _{REF}	Ext	0.1	10	—	Y	PLCC/SOIC/SSOP-20	1.90
TLC1549	10	38	4	1 SE	Serial, SPI	V _{REF}	Ext	0.1	10	—	N	PDIP-8, SOIC-8	1.71
TLV1543	10	38	2.64	11 SE	Serial, SPI	V _{REF}	Ext	0.1	10	—	N	CDIP, LCCC, PDIP, PLCC, SOIC, SSOP-20	2.15
TLC1541	10	32	6	11 SE	Serial, SPI	V _{REF}	Ext	0.1	10	—	N	PDIP, PLCC, SOIC-20	3.20
8-Bit SAR ADCs													
ADS7885	8	3,000	15	1 SE	Serial, SPI	V _{DD} (2.7V to 5.5V)	Ext (V _{DD})	0.156	8	49.8	N	SOT-23-6	0.95
ADS7949	8	2,000	7	2 PDiff	Serial, SPI	V _{REF}	Ext	0.0234	12	—	N	3x3 QFN-16	0.99
TLV571	8	1,250	12	1 SE	P8	V _{REF}	Ext	0.5	8	49	N	SOIC-24, TSSOP-24	2.35
ADS7888	8	1,250	8	1 SE	Serial, SPI	V _{DD} (2.35V to 5.25V)	Ext (V _{DD})	0.2	8	49.5	N	SOT-23-6, SC-70	0.85
ADS7961	8	1,000	12.5	16 SE	Serial, SPI	V _{REF} (2.5V)	Ext	0.112	8	49	N	TSSOP-38	2.45
ADS7960	8	1,000	12.5	12 SE	Serial, SPI	V _{REF} (2.5V)	Ext	0.112	8	49	N	TSSOP-38	2.05
ADS7959	8	1,000	12.5	8 SE	Serial, SPI	V _{REF} (2.5V)	Ext	0.112	8	49	N	TSSOP-30	1.65
ADS7958	8	1,000	12.5	4 SE	Serial, SPI	V _{REF} (2.5V)	Ext	0.112	8	49	N	TSSOP-30	1.25
TLC0820A	8	392	37.5	1 SE	P8	V _{REF}	Ext	0.2	8	—	N	PLCC, SOIC, SSOP-20	1.90
ADS7827	8	250	0.6	1 PDiff	Serial, SPI	V _{REF}	Ext	0.2	8	48	N	QFN-8	1.00
ADS7868	8	200	0.25	1 SE, 1 PDiff	Serial, SPI	V _{DD} (1.2V to 3.6V)	Ext	0.1	8	50	N	SOT-23-6	0.80
TLC545	8	76	6	19 SE	Serial, SPI	V _{REF}	Ext	0.2	8	—	N	PDIP-28, PLCC-28	3.10
ADS7830	8	75	0.675	8 SE/4 Diff	Serial, I ² C	V _{REF}	Int/Ext	0.19	8	50	N	TSSOP-16	1.40
TLV0831	8	49	0.66	1 SE	Serial, SPI	+3.6 (V _{REF} = V _{DD})	Ext	0.2	8	—	N	PDIP-8, SOIC-8	1.40
TLC548	8	45.5	9	1 SE	Serial, SPI	V _{REF}	Ext	0.2	8	—	N	PDIP-8, SOIC-8	1.20
TLV0832	8	44.7	5	2 SE/1 Diff	Serial, SPI	V _{REF}	Ext	0.2	8	—	N	PDIP-8, SOIC-8	1.40
TLV0834	8	41	0.66	4 SE/2 Diff	Serial, SPI	V _{REF}	Ext	0.2	8	—	N	PDIP, SOIC, TSSOP-14	1.45
TLC549	8	40	9	1 SE	Serial, SPI	V _{REF}	Ext	0.2	8	—	Y	PDIP-8, SOIC-8	0.95
TLC541	8	40	6	11 SE	Serial, SPI	V _{REF}	Ext	0.2	8	—	Y	PDIP, PLCC, SOIC-20	1.50
TLV0838	8	37.9	0.66	8 S/4 Diff	Serial, SPI	V _{REF}	Ext	0.2	8	—	N	PDIP, SOIC, TSSOP-20	1.45
TLC0831	8	31	3	1 Diff	Serial, SPI	V _{REF}	Ext	0.2	8	—	N	PDIP-8, SOIC-8	1.40
TLC542	8	25	6	11 SE	Serial, SPI	V _{REF}	Ext	0.2	8	—	N	PDIP, PLCC, SOIC-20	1.50
TLC0832	8	22	12.5	2 SE/1 Diff	Serial, SPI	V _{REF}	Ext	0.2	8	—	N	PDIP-8, SOIC-8	1.40
TLC0838	8	20	3	8 SE/4 Diff	Serial, SPI	V _{REF}	Ext	0.2	8	—	N	PDIP, SOIC, TSSOP-20	1.45
TLC0834	8	20	3	4 SE/2 Diff	Serial, SPI	V _{REF}	Ext	0.2	8	—	N	PDIP-14, SOIC-14	1.45

*Suggested resale price in U.S. dollars in quantities of 1,000. See www.ti.com/hirel for HiRel options.

New products are listed in bold red.

ADCs by Architecture

→ Analog-to-Digital Converters – SAR ADCs

SAR ADC Data Acquisition Systems

Device	Res. (Bits)	Sample-Rate (kSPS)	Power (mW)	Number of Input Channels	Interface	Input Voltage (V)	V _{REF}	Linearity (%)	NMC	SINAD (dB)	HiRel Avail.	Package	Price*
SAR ADC Data Acquisition Systems													
ADS8284	18	1,000	270	4 Diff	P8/P16/P18	±V _{REF} (4.1V) at V _{REF} /2	Int/Ext	0.00095	18	TBD	N	8x8 QFN	22.00
ADS8254	16	1,000	270	4 Diff	P8/P16	±V _{REF} (4.2V) at V _{REF} /2	Int/Ext	0.0011	16	TBD	N	8x8 QFN	18.50
ADS7871	14	40	6	8 SE/4 Diff	Serial, SPI	PGA (1, 2, 4, 8, 10, 16, 20)	Int	0.03	13	—	N	SSOP-28	5.00
ADS8201	12	100	1.32	8 SE/4 Diff	Serial, SPI	PGA (1, 2, 4, 8)	Ext	0.012	12	—	N	4x4 VQFN	2.75
ADS7870	12	50	4.6	8 SE	Serial, SPI	PGA (1, 2, 4, 8, 10, 16, 20)	Int	0.06	12	72	N	SSOP-28	4.15

Bipolar Input SAR ADCs

Device	Res. (Bits)	Sample-Rate (kSPS)	Number of Input Channels	Interface	Input Voltage (V)	V _{REF}	Linearity (%)	NMC	SINAD (dB)	Power (mW)	HiRel Avail.	Package(s)	Price*
16-Bit Bipolar SAR ADCs													
ADS8568	16	600	8 SE	Serial, SPI/P16	±5, ±6, ±10, ±12	Int/Ext	0.0045	16	86.5	335	N	QFN-64	15.90
ADS8660	16	500	1 SE	Serial, SPI/P8	+5, 10, ±5, ±10, ±12	Int/Ext	0.0015	16	93.5	90	N	TQFP-32	8.50
ADS7815	16	250	1 SE	P16	±2.5	Int/Ext	0.006	15	84	200	N	SOIC-28	21.30
ADS8515	16	250	1 SE	P16	±10	Int/Ext	0.0022	16	92	100	N	SSOP-28	10.95
ADS8519	16	250	1 SE	Serial, SPI	+4, 10, ±3.3, 5, 10	Int/Ext	0.0022	16	91	100	N	SSOP-28	12.95
ADS8509	16	250	1 SE	Serial, SPI	+4, 10, ±3.3, 5, 10	Int/Ext	0.003	16	86	70	N	SOIC-20, SSOP-28	12.95
ADS8505	16	250	1 SE	P8/P16	±10	Int/Ext	0.0022	16	86	70	N	SOIC-28, SSOP-28	12.95
ADS8517	16	200	1 SE	Serial, SPI/P8	4, 5, ±10	Int/Ext	0.0022	16	89	38	N	SO-28, SSOP-28	13.00
ADS7805	16	100	1 SE	P8/P16	±10	Int/Ext	0.0045	16	86	81.5	N	PDIP-28, SOIC-28	21.80
ADS7809	16	100	1 SE	Serial, SPI	+4, 10, ±3.3, 5, 10	Int/Ext	0.0045	16	88	81.5	N	SOIC-20	25.00
ADS7825	16	40	4 SE	Serial, SPI/P8	±10	Int/Ext	0.003	16	83	50	N	PDIP-28, SOIC-28	29.55
ADS7813	16	40	1 SE	Serial, SPI	+4, 10, ±3.3, 5, 10	Int/Ext	0.003	16	89	35	N	PDIP-16, SOIC-16	24.70
ADS8513	16	40	1 SE	Serial, SPI	+4, 10, ±3.3, 5, 10	Int/Ext	0.0023	16	89.9	30	N	SOIC-16	12.00
ADS7807	16	40	1 SE	Serial, SPI/P8	4, 5, ±10	Int/Ext	0.0022	16	88	28	N	PDIP-28, SOIC-28	32.30
ADS8507	16	40	1 SE	Serial, SPI/P8	4, 5, ±10	Int/Ext	0.0022	16	88	24	N	SOIC-28	13.00

*Suggested resale price in U.S. dollars in quantities of 1,000.

Preview products are listed in **bold blue**.

ADCs by Architecture

→ Analog-to-Digital Converters – SAR ADCs

Bipolar Input SAR ADCs

Device	Res. (Bits)	Sample-Rate (kSPS)	Number of Input Channels	Interface	Input Voltage (V)	V _{REF}	Linearity (%)	NMC	SINAD (dB)	Power (mW)	HiRel Avail.	Package(s)	Price*
14-Bit Bipolar SAR ADCs													
ADS8548	14	640	8 SE	Serial, SPI/P16	±5, ±6, ±10, ±12	Int/Ext	0.006	14	83	340	N	QFN-64	12.50
TLC3578	14	200	8 SE	Serial, SPI	±10	Ext	0.006	14	79	29	N	SOIC-24, TSSOP-24	8.65
TLC3574	14	200	4 SE	Serial, SPI	±10	Ext	0.006	14	79	29	N	SOIC-24, TSSOP-24	6.85
12-Bit Bipolar SAR ADCs													
ADS8634	12	1,000	4 Pdiff	Serial, SPI	+5, 10, ±5, ±10, ±12	Int/Ext	0.021	12	TBD	22.5	N	4x4 QFN-24	2.70
ADS8638	12	1,000	8 Pdiff	Serial, SPI	+5, 10, ±2.5, ±5, ±10	Int/Ext	0.021	12	TBD	22.5	N	4x4 QFN-24	3.70
ADS8528	12	690	8 SE	Serial, SPI/P16	±5, ±6, ±10, ±12	Int/Ext	0.024	12	73	350	N	QFN-64	9.50
ADS7835	12	500	1 SE	Serial, SPI	±2.5	Int	0.024	12	72	17.5	N	VSSOP-8	2.75
ADS7800	12	333	1 SE	P8/P12	±5, 10	Int	0.012	12	72	135	N	CDIP SB-24	30.50
ADS8508	12	250	1 SE	Serial, SPI	+4, 10, ±3.3, 5, 10	Int/Ext	0.011	12	73	70	N	SSOP-28, SOIC-20	10.50
ADS8504	12	250	1 SE	P8/P16	±10	Int/Ext	0.011	12	72	70	N	SSOP-28, SOIC-28	10.50
TLC2578	12	200	8 SE	Serial, SPI	±10	Ext	0.024	12	79	29	N	SOIC-24, TSSOP-24	5.80
TLC2574	12	200	4 SE	Serial, SPI	±10	Ext	0.024	12	79	29	N	SOIC-20, TSSOP-20	5.30
ADS774	12	125	1 SE	P12	10, 20, ±5, ±10	Int	0.024	12	68	120	N	PDIP-28, SOIC-28	18.25
ADS7804	12	100	1 SE	P8/P16	±10	Int/Ext	0.011	12	72	81.5	N	PDIP-28, SOIC-28	16.55
ADS7808	12	100	1 SE	Serial, SPI	+4, 10, ±3.3, 5, 10	Int/Ext	0.011	12	73	81.5	N	SOIC-20	12.80
ADS7824	12	40	4 SE	Serial, SPI/P8	±10	Int/Ext	0.012	12	73	50	N	PDIP-28, SOIC-28	13.10
ADS7812	12	40	1 SE	Serial, SPI	+4, 10, ±3.3, 5, 10	Int/Ext	0.012	12	74	35	N	PDIP-16, SOIC-16	11.80
ADS7806	12	40	1 SE	Serial, SPI/P8	+4, 5, ±10	Int/Ext	0.011	12	73	28	N	PDIP-28, SOIC-28	15.05
ADS8512	12	40	1 SE	Serial, SPI	+4, 10, ±3.3, 5, 10	Int/Ext	0.011	12	74	24	N	SOIC-16	7.00
ADS8506	12	40	1 SE	Serial, SPI/P8	+4, 5, ±10	Int/Ext	0.011	12	73	24	N	SOIC-28	7.00
8-Bit Bipolar SAR ADCs													
ADS8614	8	1,000	4 Pdiff	Serial, SPI	+5, 10, ±2.5, ±5, ±10	Int/Ext	0.07	8	TBD	22.5	N	4x4 QFN-24	1.45
ADS8618	8	1,000	8 Pdiff	Serial, SPI	+5, 10, ±2.5, ±5, ±10	Int/Ext	0.07	8	TBD	22.5	N	4x4 QFN-24	2.05

*Suggested resale price in U.S. dollars in quantities of 1,000.

Preview products are listed in **bold blue**.

→ Analog-to-Digital Converters – Pipeline ADCs

Lowest Power, 14-Bit, 250MSPS ADC

ADS4149, ADS4146, ADS4129, ADS4126, ADS41B49, ADS41B29

Get samples, datasheets and EVMs at: www.ti.com/sc/device/PARTnumber (Replace **PARTnumber** with **ADS4149, ADS4146, ADS4129, ADS4126, ADS41B49** or **ADS41B29**)

Key Features

- 260mW power consumption; only 201mW consumption at 160MSPS with dynamic power scaling
- High performance: 70.6dB SNR with 84dBc SFDR at 170MHz IF
- 0-6dB programmable gain in 1dB steps for optimized SNR/SFDR/ input swing
- 1.8 AV_{DD} and DV_{DD} power supplies
- User-selectable DDR LVDS or CMOS outputs
- 6 pin-compatible options
 - ADS4149, ADS4129: 14- and 12-bits, 250MSPS
 - ADS4146, ADS4126: 14- and 12-bits, 160MSPS
 - ADS41B49, ADS41B29: 14- and 12-bits, 250MSPS with analog input buffers
- 7mm x 7mm, 48-pin QFN package – pin compatible to the ADS6149

Applications

- Wireless communication:
 - Digital pre-distortion feedback loops
 - Wideband digital repeaters
- Software-defined radios
- Portable man-pack receivers
- High-density, multi-mode receivers
- Portable test and measurement equipment
- Wireless communication

The ADS4149 was developed specifically to be the lowest power 14-bit ADC at the 250MSPS node. By reducing power consumption by 30% compared to the next lowest power 14-bit ADC at this node, the ADS4149 enables systems to reduce their power consumption budget for a socket that consumes a significant amount of total system power, particularly in multi-channel systems such as wireless base stations and software-defined radios.

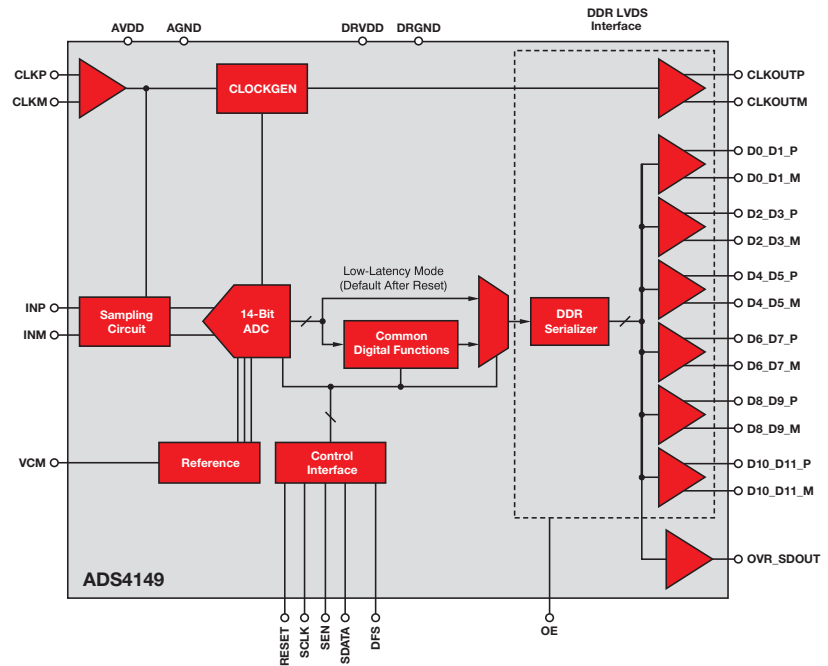

ADS4149 functional block diagram

➔ Analog-to-Digital Converters – Pipeline ADCs

Quad, Dual and Single 11-Bit, 200MSPS with ADC SNRBoost

ADS58C48, ADS58C28, ADS58B18

Get samples and datasheets at: www.ti.com/sc/device/PARTnumber (Replace **PARTnumber** with **ADS58C48**, **ADS58C28** or **ADS58B18**)

Key Features

- Lowest power consumption available by 30%
 - 215mW/ch in CMOS mode at 185MSPS
 - 317mW/ch with 60MHz SNRBoost at 185MSPS
- High-performance SNRBoost3G: 60MHz signal BW
 - 72.3dBFS SNR across 60MHz band at 140MHz
 - 83dBc SFDR across 60MHz band at 140MHz
 - 75.4dBFS SNR across 30MHz band at 140MHz
 - 85dBc SFDR across 30MHz band at 140MHz
- 6dB gain in 1dB steps for SNR/SFDR trade-off
- 14mm x 14mm, 80-pin TQFP package
- Selectable DDR LVDS or CMOS outputs with half- and full-swing LVDS modes
- 1.8V AV_{DD} and DV_{DD} supplies
- Export control compliant – no license required

Applications

- Macro/micro base station receivers
 - TD-SCDMA, CDMA, WCDMA, CDMA2k
 - LTE, TD-LTE, WiMAX
 - MC-GSM (relaxed SFDR specification)
 - Multi-standard, multi-carrier
- Base station digital pre-distortion feedback
- Software-defined radios and repeaters
- Wireless network test equipment

The ADS58C48 was designed to be the lowest power 11-bit, 4-channel ADC on the market at 200MSPS which includes a 60MHz noise-shaping resampler (SNRBoost). With 11-bit resolution and a maximum speed of 200MSPS, the device is fully exportable to controlled countries such as China and Russia. By supporting up to 60MHz of SNRBoost bandwidth at 185MSPS with high SFDR, the ADS58C48 enables wide-band multi-carrier and multi-mode receivers with a single signal chain, including CDMA, WCDMA, TD-SCDMA, LTE, WiMAX and MC-GCSM. And by offering four channels with minimal power consumption, the device enables high-density 2x4 and 4x4 receivers without creating thermal and power difficulties.

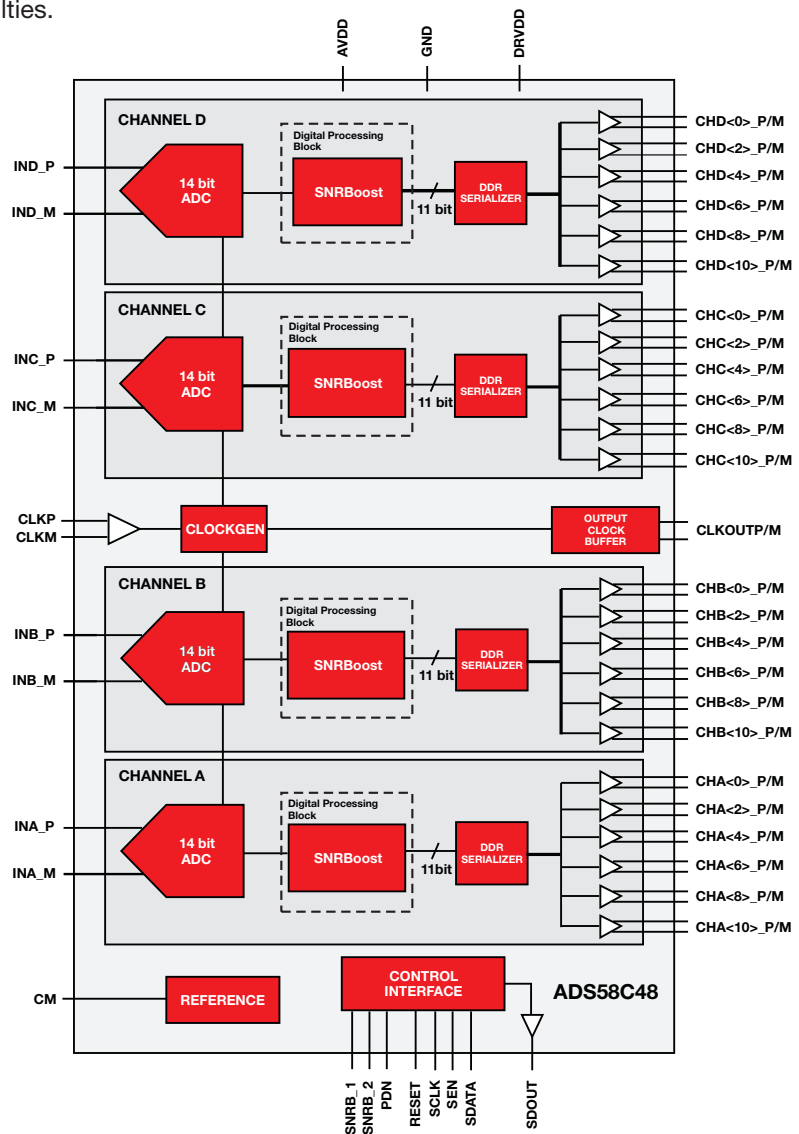

ADS58C48 functional block diagram (LVDS interface)

➔ Analog-to-Digital Converters – Pipeline ADCs

12-Bit, 1-GSPS Analog-to-Digital Converter

ADS5400

Get samples and datasheets at: www.ti.com/sc/device/ADS5400

Key Features

- 1GSPS sample-rate
- 12-bit resolution
- 2.1GHz input bandwidth
- SFDR = 66dBc at 1.2GHz
- SNR = 57.6dBFS at 1.2GHz
- 7 clock-cycle latency
- Interleave friendly: internal adjustments for gain, phase and offset
- 1.5V to 2V selectable full-scale range
- LVDS-compatible outputs, 1 or 2 bus options
- Total power dissipation: 2.15W

Applications

- Radar and guidance systems
- Defense electronics digitizers
- Test, measurement and instrumentation
- General purpose high-speed digitizers
- Wireless communication:
 - Satellite modems
 - Wideband I/Q receivers
 - Wireless back-haul

The ADS5400 was designed to be the first 12-bit ADC to offer up to a 1GSPS sample-rate. This allows the ADS5400 to offer unmatched SNR and SFDR at extremely high input frequencies when compared to current 8- and 10-bit ADCs at this speed, as high as 58.8dBFS SNR with 72dBc SFDR at 600MHz IF, while doubling the instantaneous signal capture bandwidth over lower speed 12-bit solutions. The device was also designed to allow customers to easily implement interleaving solutions with multiple ADS5400 ADCs, allowing them to design multi-gigasample 12-bit digitizers.

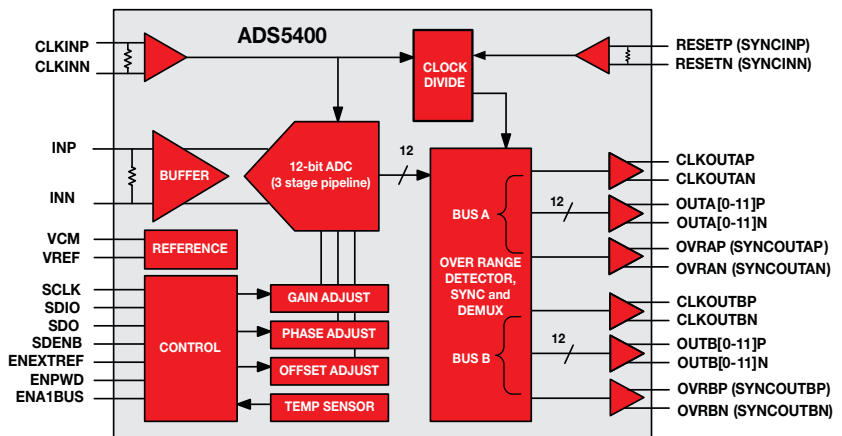

ADS5400 functional block diagram

Pipeline ADCs

Device	Res. (Bits)	Sample-Rate (MSPS)	No. of Input Channels	Input Voltage (V)	Analog Input Bandwidth (MHz)	DNL (± LSB)	INL (± LSB)	SNR (dB)	SFDR (dB)	Supply Voltage (V)	Power (mW)	HiRel Avail.	Package	Price*
ADS5485	16	200	1 Diff	3	730	0.99	10	75	87	4.75, 5.25	2160	N	QFN-64	98.95
ADS5484	16	170	1 Diff	3	730	0.99	10	75.7	87	4.75, 5.25	2160	N	QFN-64	78.95
ADS5483	16	135	1 Diff	3	485	0.5	3	79	97	4.75, 5.25	2130	N	QFN-64	65.00
ADS5493	16	130	1 Diff	2.2	600	0.99	10	76	100	4.75, 5.25	1750	N	QFN-48	65.00
ADS5482	16	105	1 Diff	3	125	0.5	3	80.5	98	4.75, 5.25	2100	N	QFN-64	56.65
ADS5481	16	80	1 Diff	3	125	0.5	3	80.6	98	4.75, 5.25	2100	N	QFN-64	48.33
ADS5562	16	80	1 Diff	3.56	300	0.95	8.5	84	85	3.0, 3.6	865	N	QFN-48	48.35
ADS5560	16	40	1 Diff	3.56	300	0.95	8.5	84.3	90	3.0, 3.6	674	N	QFN-48	31.80
ADS5474	14	400	1 Diff	2.2	1440	0.7	1	70.2	86	4.75, 5.25	2500	N	HTQFP-80	160.65
ADS6149	14	250	1 Diff	2	800	0.4	2	72.7	86	3.0, 3.6	687	N	QFN-48	96.50
ADS4149	14	250	1 Diff	2	800	0.5	2	72.9	80	1.7, 1.9	265	N	QFN-48	89.00
ADS61B49	14	250	1 Diff	2	800	0.4	2	72.4	86	3.0, 3.6	790	N	QFN-48	99.95
ADS41B49	14	250	1 Diff	1.78	600	0.5	2	71.7	80	1.7, 1.9	350	N	QFN-48	92.50
ADS62P49	14	250	2 Diff	2	800	0.6	2.5	73	85	3.0, 3.6	1250	N	QFN-64	144.75
ADS5547	14	210	1 Diff	2	800	0.5	3.5	73.3	85	3.0, 3.6	1230	N	QFN-48	82.50
ADS6148	14	210	1 Diff	2	700	0.4	2	72.7	82	3.0, 3.6	628	N	QFN-48	74.25
ADS62P48	14	210	2 Diff	2	800	0.6	2.5	73	85	3.0, 3.6	140	N	QFN-64	120.00
ADS5546	14	190	1 Diff	2	500	0.5	3	73.2	84	3.0, 3.6	1130	N	QFN-48	72.50
ADS5545	14	170	1 Diff	2	500	0.5	3	73.5	85	3.0, 3.6	1100	N	QFN-48	62.50
ADS4146	14	160	1 Diff	2	800	0.5	2	73	83	1.7, 1.9	200	N	QFN-48	49.00
ADS5500	14	125	1 Diff	2	750	0.75	2.5	70.5	82	3.0, 3.6	780	Y	HTQFP-64	49.00
ADS6145	14	125	1 Diff	2	450	0.6	2.5	74.1	84	3.0, 3.6	417	N	QFN-32	36.90
ADS4145	14	125	1 Diff	2	800	0.5	2	73	85	1.7, 1.9V	140	N	QFN-64	34.15

*Suggested resale price in U.S. dollars in quantities of 1,000. See www.ti.com/hirel for HiRel options.

New products are listed in bold red. Preview products are listed in bold blue.

➔ Analog-to-Digital Converters – Pipeline ADCs

Pipeline ADCs (continued)

Device	Res. (Bits)	Sample-Rate (MSPS)	No. of Input Channels	Input Voltage (V)	Analog Input Bandwidth (MHz)	DNL (± LSB)	INL (± LSB)	SNR (dB)	SFDR (dB)	Supply Voltage (V)	Power (mW)	HiRel Avail.	Package(s)	Price*
ADS6245	14	125	2 Diff	2	500	0.6	3	73.2	83	3.0, 3.6	1000	N	QFN-48	60.00
ADS62P45	14	125	2 Diff	2	450	0.8	3	73.8	85	3.0, 3.6	792	N	QFN-64	60.00
ADS6445	14	125	4 Diff	2	500	0.6	3	73.2	83	3.0, 3.6	1680	Y	QFN-64	117.00
ADS5424	14	105	1 Diff	2.2	570	-0.95, 1.5	1.5	74	93	4.75, 5.25	1900	Y	HTQFP-52	56.00
ADS5541	14	105	1 Diff	2	750	-0.9, 1.1	5	72	85.1	3.0, 3.6	739	N	HTQFP-64	41.00
ADS6144	14	105	1 Diff	2	450	0.6	2.5	74.1	84	3.0, 3.6	374	N	QFN-32	31.90
ADS6244	14	105	2 Diff	2	500	0.6	3	73	81	3.0, 3.6	810	N	QFN-48	51.05
ADS62P44	14	105	2 Diff	2	450	0.7	2.5	73.8	86	3.0, 3.6	700	N	QFN-64	61.05
ADS6444	14	105	4 Diff	2	500	0.6	3	73	81	3.0, 3.6	1350	N	QFN-64	99.00
ADS5423	14	80	1 Diff	2.2	570	-0.95, 1.5	1.5	74	94	4.75, 5.25	1850	N	HTQFP-52	40.00
ADS5433	14	80	1 Diff	2.2	570	-0.95, 1.5	1.5	74	97.2	4.75, 5.25	1850	N	HTQFP-52	48.00
ADS5542	14	80	1 Diff	2	750	-0.9, 1.1	5	72.9	88	3.0, 3.6	674	N	HTQFP-64	25.00
ADS6143	14	80	1 Diff	2	450	0.5	2	74.4	89	3.0, 3.6	318	N	QFN-32	25.00
ADS6243	14	80	2 Diff	2	500	0.5	2	73.8	87.5	3.0, 3.6	700	N	QFN-48	37.50
ADS62P43	14	80	2 Diff	2	450	0.5	1.5	74.3	88	3.0, 3.6	587	N	QFN-64	37.50
ADS6443	14	80	4 Diff	2	500	0.5	2	73.8	87.5	3.0, 3.6	1180	N	QFN-64	63.00
ADS5553	14	65	2 Diff	2.3	750	1	4	74	84	3.0, 3.6	890	N	HTQFP-80	30.00
ADS6142	14	65	1 Diff	2	450	0.5	2	74.6	89	3.0, 3.6	285	N	QFN-32	18.65
ADS6242	14	65	2 Diff	2	500	0.5	2	74	88	3.0, 3.6	630	N	QFN-48	30.85
ADS62P42	14	65	2 Diff	2	450	0.4	1.5	74.4	88	3.0, 3.6	518	N	QFN-64	30.85
ADS6442	14	65	4 Diff	2	500	0.5	2	74	88	3.0, 3.6	1180	N	QFN-64	57.05
ADS5422	14	62	1 Diff	2 to 4	300	1	—	72	85	4.75, 5.25	1200	N	LQFP-64	30.45
ADS5421	14	40	1 Diff	2 to 4	300	1	—	75	83	4.75, 5.25	900	N	LQFP-64	20.15
ADS850	14	10	1 SE/1 Diff	2 to 4	300	1	5	76	85	4.7, 5.3	250	N	TQFP-48	10.50
THS1408	14	8	1 SE/1 Diff	1.5	140	1	5	72	80	3.0, 3.6	270	Y	HTQFP-48	14.85
THS1403	14	3	1 SE/1 Diff	1.5	140	1	5	72	80	3.0, 3.6	270	N	HTQFP-48	11.05
THS14F03	14	3	1 SE/1 Diff	1.5	140	1	2.5	72	80	3.0, 3.6	270	N	TQFP-48	12.60
THS1401	14	1	1 SE/1 Diff	1.5	140	1	5	72	80	3.0, 3.6	270	N	HTQFP-48	8.90
THS14F01	14	1	1 SE/1 Diff	1.5	140	1	2.5	72	80	3.0, 3.6	270	N	TQFP-48	9.65
ADS5444	13	250	1 SE/1 Diff	2.2	800	0.4	2.5	68.7	73	4.75, 5.25	2100	Y	HTQFP-80	59.00
ADS5440	13	210	1 SE/1 Diff	2.2	800	0.4	2.5	69	80	4.75, 5.25	2100	Y	HTQFP-80	42.00
ADS5400	12	1000	1 Diff	2	2100	0.7	2	59.1	75	4.75, 5.25	2200	Y	HTQFP-100	775.00
ADS54RF63	12	550	1 Diff	2.2	2300	0.95	2.5	62.6	76	4.75, 5.25	2250	N	HTQFP-80	177.00
ADS5463	12	500	1 Diff	2.2	2000	0.25	2.5	65.2	84	4.75, 5.25	2200	Y	HTQFP-80	135.75
ADS6129	12	250	1 Diff	2	700	0.2	1	70.5	86	3.0, 3.6	687	N	QFN-48	52.85
ADS4129	12	250	1 Diff	2	800	0.2	0.25	70.4	80	1.7, 1.9	265	N	QFN-48	45.00
ADS61B29	12	250	1 Diff	2	800	0.2	1	70	86	3.0, 3.6	790	N	QFN-48	56.30
ADS41B29	12	250	1 Diff	1.78	600	0.2	1	69.2	80	1.7, 1.9	350	N	QFN-48	48.45
ADS62P29	12	250	2 Diff	2	800	0.2	1	70.5	85	3.0, 3.6	1250	N	QFN-64	79.50
ADS5527	12	210	1 Diff	2	800	0.5	2	69	81	3.0, 3.6	1230	N	QFN-48	45.00
ADS6128	12	210	1 Diff	2	700	0.2	1	70.5	82	3.0, 3.6	628	N	QFN-48	41.50
ADS62P28	12	210	2 Diff	2	800	0.2	1	70.6	85	3.0, 3.6	1140	N	QFN-64	62.25
ADS5525	12	170	1 Diff	2	500	0.5	1.5	70.5	84	3.0, 3.6	1100	N	QFN-48	35.00
ADS4126	12	160	1 Diff	2	800	0.2	0.25	70.5	83	1.7, 1.9	200	N	QFN-48	26.00
ADS5520	12	125	1 Diff	2	750	0.5	1.5	69.7	83.6	3.0, 3.6	780	N	HTQFP-64	27.50
ADS6125	12	125	1 Diff	2	450	0.6	2.5	71.3	84	3.0, 3.6	417	N	QFN-32	24.55
ADS4125	12	125	1 Diff	2	800	0.2	0.25	70.5	83	1.7, 1.9	140	N	QFN-64	20.85
ADS6225	12	125	2 Diff	2	500	0.5	2.5	70.3	83	3.0, 3.6	1000	N	QFN-64	20.85
ADS62P25	12	125	2 Diff	2	450	0.8	3	70.8	85	3.0, 3.6	792	N	QFN-64	36.85
ADS6425	12	125	4 Diff	2	500	0.5	2.5	70.3	83	3.0, 3.6	1650	N	QFN-64	68.60
ADS5521	12	105	1 Diff	2	750	0.5	1.5	70	86	3.0, 3.6	736	N	HTQFP-64	23.00
ADS6124	12	105	1 Diff	2	450	0.5	2	71.3	84	3.0, 3.6	374	N	QFN-32	20.75
ADS6224	12	105	2 Diff	2	500	0.5	2.2	70.6	81	3.0, 3.6	900	900	QFN-48	31.60

*Suggested resale price in U.S. dollars in quantities of 1,000. See www.ti.com/hirel for HiRel options.

New products are listed in bold red. Preview products are listed in bold blue.

➔ Analog-to-Digital Converters – Pipeline ADCs

Pipeline ADCs (continued)

Device	Res. (Bits)	Sample-Rate (MSPS)	No. of Input Channels	Input Voltage (V)	Analog Input Bandwidth (MHz)	DNL (± LSB)	INL (± LSB)	SNR (dB)	SFDR (dB)	Supply Voltage (V)	Power (mW)	HiRel Avail.	Package(s)	Price*
ADS62P24	12	105	2 Diff	2	450	0.7	2.5	71	86	3.0, 3.6	700	N	QFN-64	31.60
ADS6424	12	105	4 Diff	2	500	0.5	2.2	70.6	81	3.0, 3.6	1350	N	QFN-64	58.50
ADS5410	12	80	1 SE/1 Diff	2	1000	1	2	65	76	3.0, 3.6	360	N	TQFP-48	19.00
ADS5522	12	80	1 Diff	2	750	0.5	1.5	69.7	82.8	3.0, 3.6	663	N	HTQFP-64	16.70
ADS809	12	80	1 SE/1 Diff	1 to 2	1000	1.7	6	63	67	4.75, 5.25	905	N	TQFP-48	24.95
ADS6123	12	80	1 Diff	2	450	0.5	2	71.5	89	3.0, 3.6	318	N	QFN-32	16.50
ADS61B23	12	80	1 Diff	2	450	0.5	2	70	82	3.0, 3.6	351	N	QFN-32	19.50
ADS6223	12	80	2 Diff	2	500	0.4	2	70.9	87	3.0, 3.6	760	N	QFN-48	25.05
ADS62P23	12	80	2 Diff	2	450	0.5	1.5	71.2	88	3.0, 3.6	587	N	QFN-64	25.05
ADS6423	12	80	4 Diff	2	500	0.4	2	70.9	87	3.0, 3.6	1180	N	QFN-64	44.30
ADS808	12	70	1 SE/1 Diff	1 to 2	1000	1.7	7	64	68	4.75, 5.25	720	N	TQFP-48	19.50
ADS5273	12	70	8 Diff	1.5	300	0.99, 1.2	3	71	85	3.0, 3.6	1003	N	HTQFP-80	121.00
ADS5413	12	65	1 Diff	2	1000	1	2	68.5	79	3.0, 3.6	400	N	HTQFP-48	14.75
ADS5221	12	65	1 SE/1 Diff	1 to 2	300	1	1.5	70	88	3.0, 3.6	285	N	TQFP-48	13.95
ADS6122	12	65	1 Diff	2	450	0.5	2	71.6	89	3.0, 3.6	318	N	QFN-32	12.00
ADS5232	12	65	2 Diff	2	300	0.9	2	70.7	86	3.0, 3.6	340	N	TQFP-64	16.00
ADS6222	12	65	2 Diff	2	500	0.4	2	71.2	89	3.0, 3.6	760	N	QFN-48	18.10
ADS62P22	12	65	2 Diff	2	450	0.4	1.5	71.3	88	3.0, 3.6	518	N	QFN-64	18.10
ADS5242	12	65	4 Diff	1.5	300	0.95, 1	2	71	85	3.0, 3.6	660	N	HTQFP-64	30.00
ADS6422	12	65	4 Diff	2	500	0.4	2	71.2	88	3.0, 3.6	1180	N	QFN-64	31.65
ADS5272	12	65	8 Diff	1.5	300	0.95, 1	2	71.1	85	3.0, 3.6	984	N	HTQFP-80	54.85
ADS5282	12	65	8 Diff	2	520	0.3	1.5	70	85	3.0, 3.6	616	N	QFN-64	54.85
ADS807	12	53	1 SE/1 Diff	2 to 3	270	1	4	69	82	4.75, 5.25	335	N	SSOP-28	11.30
ADS2807	12	50	2 SE/2 Diff	2 to 3	270	1	5	65	70	4.75, 5.25	720	N	TQFP-64	18.05
ADS5271	12	50	8 Diff	1.5	300	0.9	2	70.5	85	3.0, 3.6	927	N	HTQFP-80	48.00
ADS5281	12	50	8 Diff	2	52	0.3	1.5	70	85	3.0, 3.6	510	N	QFN-64, HTQFP-80	48.00
ADS5220	12	40	1 SE/1 Diff	1 to 2	300	1	1.5	70	88	3.0, 3.6	195	N	TQFP-48	9.85
ADS800	12	40	1 SE/1 Diff	2	65	1	—	62	61	4.75, 5.25	390	N	SO-28, TSSOP-28	30.85
ADS5231	12	40	2 Diff	2	300	0.9	2	70.7	86	3.0, 3.6	285	N	TQFP-64	11.75
ADS5240	12	40	4 Diff	1.5	300	0.9	2	70.5	85	3.0, 3.6	607	N	HTQFP-64	20.00
ADS5270	12	40	8 Diff	1.5	300	0.9	2	70.5	85	3.0, 3.6	888	N	HTQFP-80	44.00
ADS2806	12	32	2 SE/2 Diff	2 to 3	270	1	4	66	73	4.75, 5.25	430	N	TQFP-64	14.10
THS1230	12	30	1 SE/1 Diff	1 to 2	180	1	2.5	67.7	74.6	3.0, 3.6	168	N	SOIC-28, TSSOP-28	10.50
ADS801	12	25	1 SE/1 Diff	1 to 2	65	1	—	64	61	4.75, 5.25	270	N	SO-28, SSOP-28	12.55
ADS805	12	20	1 SE/1 Diff	2	270	0.75	2	68	74	4.75, 5.25	300	N	SSOP-28	9.90
THS1215	12	15	1 SE/1 Diff	1 to 2	180	0.9	1.5	68.9	81.7	3.0, 3.6	148	N	SOIC-28, SSOP-28	9.85
ADS802	12	10	1 SE/1 Diff	2	65	1	2.75	66	66	4.75, 5.25	260	N	SO-28, SSOP-28	12.60
ADS804	12	10	1 SE/1 Diff	2	270	0.75	2	69	80	4.7, 5.3	180	N	SSOP-28	9.20
THS12082	12	8	2 SE/1 Diff	2.5	96	1	1.5	69	71	4.75, 5.25	186	Y	TSSOP-32	8.40
THS1209	12	8	2 SE/1 Diff	2.5	98	1	1.5	69	71	4.75, 5.25	186	N	TSSOP-32	7.90
THS1206	12	6	4 SE/2 Diff	2.5	96	1	1.8	69	71	4.75, 5.25	186	Y	TSSOP-32	7.80
THS1207	12	6	4 SE/2 Diff	2.5	96	1	1.5	69	71	4.75, 5.25	186	N	TSSOP-32	7.25
ADS803	12	5	1 SE/1 Diff	2	270	2	0.75	69	82	4.7, 5.3	115	N	SSOP-28	7.40
ADS5517	11	200	1 Diff	2	800	0.3	1.5	66.9	84	3.0, 3.6	1230	N	QFN-48	32.95
ADS58B18	11	200	1 Diff	2	600	0.25	0.5	66.2	87	1.7, 1.9	368	N	QFN-48	39.95
ADS62C17	11	200	2 Diff	2	800	0.2	0.75	67	85	3.0, 3.15	1081	N	QFN-64	66.00
ADS58C28	11	200	2 Diff	2	600	0.25	1	66.6	84	1.7, 1.9	505	N	QFN-64	63.95
ADS58C48	11	200	4 Diff	2	600	0.25	1	66.6	84	1.7, 1.9	900	N	HTQFP-80	111.95

*Suggested resale price in U.S. dollars in quantities of 1,000. See www.ti.com/hirel for HiRel options.

New products are listed in bold red.

➔ Analog-to-Digital Converters – Pipeline ADCs

Pipeline ADCs (continued)

Device	Res. (Bits)	Sample-Rate (MSPS)	No. of Input Channels	Input Voltage (V)	Analog Input Bandwidth (MHz)	DNL (\pm LSB)	INL (\pm LSB)	SNR (dB)	SFDR (dB)	Supply Voltage (V)	Power (mW)	HiRel Avail.	Package(s)	Price*
ADS5510	11	125	1 Diff	2	750	1.1	5	66.8	83	3.0, 3.6	780	N	HTQFP-64	14.20
ADS62C15	11	125	2 Diff	2	450	0.4	3.5	67	82	3.0, 3.6	740	N	QFN-64	41.25
ADS62P15	11	125	2 Diff	2	450	0.4	3.5	67.1	85	3.0, 3.6	740	N	QFN-64	18.00
ADS5411	11	105	1 Diff	2.2	750	0.5	0.5	66.4	90	4.75, 5.25	1900	N	HTQFP-52	25.50
ADS5413-11	11	65	1 Diff	2	1000	0.75	1	65	77	3.0, 3.6	400	N	HTQFP-48	14.75
ADS828	10	75	1 SE/1 Diff	2	300	1	3	57	68	4.75, 5.25	340	N	SSOP-28	8.70
ADS5102	10	65	1 Diff	1	950	1	2.5	57	71	1.65, 2.0	160	N	TQFP-48	7.10
ADS5237	10	65	2 Diff	2	300	0.1	1	61.7	85	3.0, 3.6	330	N	HTQFP-64	7.50
ADS5277	10	65	8 Diff	1.5	300	0.5	1	61.7	85	3.0, 3.6	911	N	HTQFP-80	32.00
ADS5287	10	65	8 Diff	2	520	0.1	1	61.7	85	3.0, 3.6	592	N	QFN-64	32.00
ADS5122	10	65	8 Diff	1	22	1	2.5	59	72	1.65, 2.0	733	N	BGA-257	42.85
ADS823	10	60	1 SE/1 Diff	2	300	1	2	60	74	4.75, 5.25	295	N	SSOP-28	8.40
ADS826	10	60	1 SE/1 Diff	2	300	1	2	59	73	4.75, 5.25	295	N	SSOP-28	8.40
ADS5103	10	40	1 Diff	1	950	0.8	1.5	58	66	1.65, 2.0	105	N	TQFP-48	5.25
ADS821	10	40	1 SE/1 Diff	2	65	1	2	58	62	4.75, 5.25	390	N	SSOP-28	13.05
ADS822	10	40	1 SE/1 Diff	2	300	1	2	60	66	4.75, 5.25	200	N	SSOP-28	5.25
ADS825	10	40	1 SE/1 Diff	2	300	1	2	60	65	4.75, 5.25	200	N	SSOP-28	5.25
THS1040	10	40	1 SE/1 Diff	2	900	0.9	1.5	57	70	3.0, 3.6	100	N	SOIC-28	5.10
THS1041	10	40	1 SE/1 Diff	2	900	1	1.5	57	70	3.0, 3.6	103	N	SOIC-28	5.45
ADS5203	10	40	2 SE/2 Diff	1	300	1	1.5	60.5	73	3.0, 3.6	240	N	TQFP-48	9.65
ADS5204	10	40	2 SE/2 Diff	2	300	1	1.5	60.5	73	3.0, 3.6	275	Y	TQFP-48	11.05
ADS5120	10	40	8 Diff	1	300	1	1.5	58	72	1.65, 2	794	N	BGA-257	36.15
ADS5121	10	40	8 Diff	1	28	1	1.5	60	74	1.65, 2.0	500	N	BGA-257	38.85
THS1030	10	30	1 SE/1 Diff	2	150	1	2	49.4	53	3.0, 5.5	150	N	SOIC-28	3.75
THS1031	10	30	1 SE/1 Diff	2	150	1	2	49.3	52.4	3.0, 5.5	160	N	SOIC-28	4.10
ADS820	10	20	1 SE/1 Diff	2	65	1	2	60	62	4.75, 5.25	200	N	SSOP-28	6.75
ADS900	10	20	1 SE/1 Diff	1 to 2	100	1	—	49	53	2.7, 3.7	54	N	SSOP-28	3.55
ADS901	10	20	1 SE/1 Diff	1 to 2	100	1	—	53	49	2.7, 3.7	49	N	SSOP-28	3.40
THS10082	10	8	2 SE/1 Diff	2.5	96	1	1	61	65	4.75, 5.25	186	N	TSSOP-32	3.70
THS1009	10	8	2 SE/1 Diff	+1.5, +3.5	96	1	1	61	65	4.75, 5.25	186	N	TSSOP-32	3.20
THS10064	10	6	4 SE/2 Diff	2.5	96	1	1	61	65	4.75, 5.25	186	N	TSSOP-32	4.15
THS1007	10	6	4 SE/2 Diff	+1.5, +3.5	96	1	1	61	65	4.75, 5.25	186	N	TSSOP-32	3.70
TLV1562	10	2	4 SE/2 Diff	3	120	1.5	1.5	58	70.3	2.7, 5.5	15	N	SOIC-28	4.15
ADS831	8	80	1 SE/1 Diff	1 or 2	300	1	2	49	65	4.75, 5.25	310	N	SSOP-20	3.15
ADS830	8	60	1 SE/1 Diff	1 or 2	300	1	1.5	49.5	65	4.75, 5.25	215	N	SSOP-20	2.75
TLC5540	8	40	1 SE	2	75	1	1	44	42	4.75, 5.25	85	N	SOP-24	1.99
THS0842	8	40	2 SE/2 Diff	1.3	600	2	2.2	42.7	52	3.0, 3.6	320	N	TQFP-48	5.05
TLV5535	8	35	1 SE	1 to 1.6	600	1.3	2.4	46.5	58	3.0, 3.6	106	Y	TSSOP-28	2.40
ADS931	8	30	1 SE	1 to 4	100	1	2.5	48	49	2.7, 5.5	154	N	SSOP-28	2.20
ADS930	8	30	1 SE/1 Diff	1	100	1	2.5	46	50	2.7, 5.25	168	N	SSOP-28	2.30
TLC5510	8	20	1 SE	2	14	0.75	1	46	42	4.75, 5.25	127.5	N	SOP-24	1.95
TLC5510A	8	20	1 SE	2	14	0.75	1	46	42	4.75, 5.25	150	N	SOP-24	1.95

*Suggested resale price in U.S. dollars in quantities of 1,000. See www.ti.com/hirel for HiRel options.

➔ Digital-to-Analog Converters – String and R2R DACs

NEW

8-/10-/12-Bit, 8-Channel, Ultra-Low Glitch, Voltage Output DAC with 2-Wire I²C Interface

DAC7678, DACx578 family

Get samples, datasheets and EVMs at: www.ti.com/sc/device/PARTnumber (Replace **PARTnumber** with **DAC7678**, **DAC7578**, **DAC6578**, **DAC5578**)

Key Features

- Designed for high density applications
 - 8 channels in QFN-24 (4 x 4 mm), TSSOP-16 packages
 - I²C interface
 - 2.5V precision reference
- Excellent low-power performance (0.28 mW/ch)
 - ± 1 LSB (max) INL
 - Ultra-low glitch 0.15nV-sec
 - 7 μs settling time
- Wide temp range: -40°C to +125°C
- Available in 8-bit (DAC5578), 10-bit (DAC6578) and 12-bit (DAC7578) versions without integrated reference

Applications

- PA control – bias control
- Optical control
- Digital gain and offset control
- Consumer products
- Average power control (APC)

The DAC7678 family is a low-power, voltage-output, eight-channel, 8-/10-/12-bit family of DACs. The DAC7678 includes a 2.5V internal reference, giving a full-scale output voltage range of 5V. The internal reference can source up to 20mA at the VREFIN/VREFOUT pin. The device is monotonic, provides very good linearity, and minimizes undesired code-to-code transient voltages (glitch). These devices are great for high-channel count applications that require a low-density I²C interface with low power and great performance.

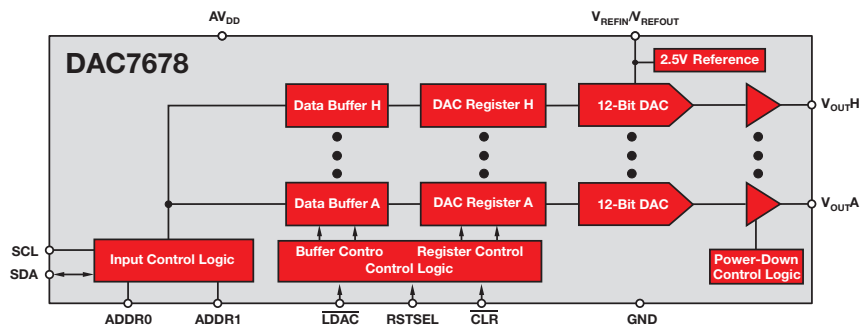

DAC7678 functional block diagram

12-/14-/16-Bit, Dual-Ch, Voltage-Output DAC in Tiny QFN-10 and MSOP-10 Packages

NEW

DAC8562, DAC8162, DAC7562

Get samples, datasheets and EVMs at: www.ti.com/sc/device/PARTnumber (Replace **PARTnumber** with **DAC8562**, **DAC8162**, **DAC7562**)

Key Features

- Designed for low power performance in tiny packages
 - DAC7562 (12-bit): 0.3 LSB INL
 - DAC8162 (14-bit): 1 LSB INL
 - DAC8562 (16-bit): 4 LSB INL
 - 2.5 V internal reference with 5 ppm/°C max. drift
 - Ultra-Low glitch energy 0.1nV-sec
 - Power consumption: 0.27mW/ch
- Wide temp range: -40°C to +125°C
- Tiny packages: 10-pin QFN (3x3mm), 10-pin MSOP (3x5mm)

Applications

- Portable instrumentation
- Closed-loop servo/process control
- Data-acquisition systems
- Programmable attenuation, digital gain and offset adjustment
- Programmable voltage/current sources

This is a family of low-power, voltage-output, dual-channel, 12/14/16-bit DACs. These devices include a 2.5V, 2ppm/°C internal reference, giving a full-scale output voltage range of 2.5V or 5V. The internal reference has an initial accuracy of 1mV and can source up to 20mA at the VREFIN/VREFOUT pin. These devices are monotonic, providing excellent linearity and minimizing undesired code-to-code transient voltages (glitch). The three-wire serial interface is compatible with standard SPI[™], QSPI[™], Microwire[™] and digital signal processor (DSP) interfaces.

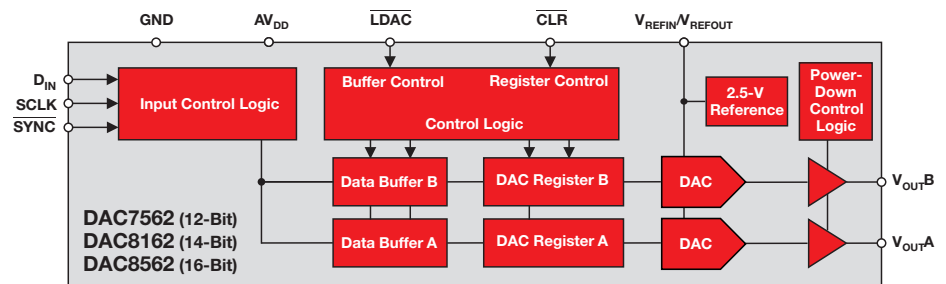

DAC7562, DAC8162, DAC8562 functional block diagram

Digital-to-Analog Converters – String and R2R DACs

16-Bit Octal, High Voltage Bipolar Output, Low Power, Serial Input DAC

DAC8718

NEW

Get samples, datasheets and EVMs at: www.ti.com/sc/device/DAC8718

Key Features

- Widest output voltage range
 - Bipolar $\pm 16.5V$ or unipolar 0 to 33V
- Speed and accuracy
 - Settling time: 10 μ s to 0.03% accuracy
 - INL: ± 4 LSB (max)
 - After user calibration INL: ± 1 LSB (max)
 - Low glitch energy: 4nV-s typ
- Flexibility
 - Programmable dual offset DACs
 - Programmable gain: 4x or 6x
 - Analog mux for monitoring output
 - Wide temp range: $-40^{\circ}C$ to $+105^{\circ}C$
 - QFN-48 (7x7), QFN-56 (8x8) and TQFP-64 (10x10)
- Available in 12/14/16-bit versions with SPI™/parallel interface

Applications

- Test equipment/ATE
- PLC and industrial process control
- Instrumentation
- Machine and motion control

The DAC8718 family is a series of low-power, octal, 12-/14-/16-bit digital-to-analog converters (DAC) available in SPI™/Parallel interfaces capable of supporting unipolar outputs up to 33V and bipolar outputs up to $\pm 16.5V$. They are trimmed in manufacturing and have very low zero-code and gain error. In addition, system level calibration can be performed to achieve ± 1 LSB zero/full-scale error with unipolar/bipolar supplies. Programmable dual offset DACs allow asymmetrical offset of DAC output ranges and an integrated multiplexer enables analog output monitoring and control. These features make the DAC8718 family ideal for use in test equipments, industrial process control and instrumentation applications.

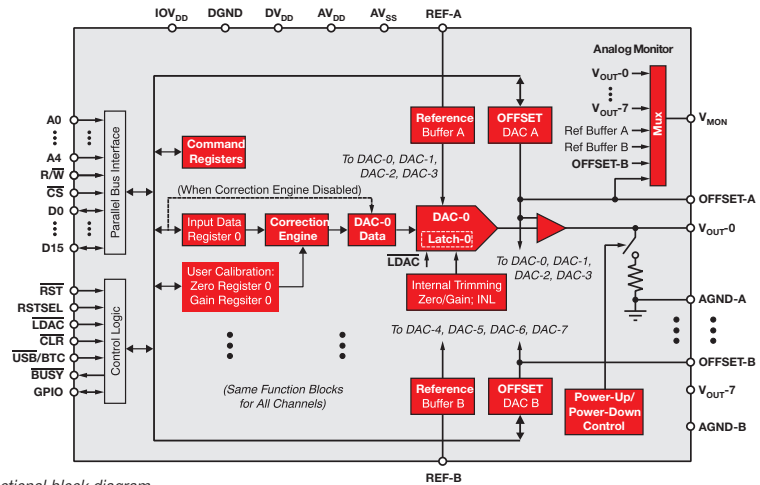

DAC8718 functional block diagram

16-Bit, Octal, Low Glitch, Low Power DAC with 2ppm/°C Temp Drift Internal Reference

DAC8568

Get samples, datasheets and EVMs at: www.ti.com/sc/device/DAC8568

Key Features

- High accuracy across temperature
 - DNL: ± 0.5 LSB, INL: ± 4 LSB at 16-bits
 - Low glitch energy: 0.1nV-s typ
 - Reference drift 2 ppm/°C (typ); 5 ppm/°C (max)
 - Wide temp range: $-40^{\circ}C$ to $+105^{\circ}C$
- High integration in small package
 - Eight DACs in TSSOP-16/14 packages
 - Integrated reference 2.5V
 - Power on reset to zero/mid-scale
- Available in 12/14/16-bit versions

Applications

- Automatic test equipment
- Portable instrumentation
- Precision waveform generation
- Industrial process control
- Medical equipment

The DAC8568 family are low power, 8-channel 12-/14-/16-bit DACs that include a 2.5V, 2ppm/°C integrated reference, giving a full scale output voltage of 2.5 or 5V. Outperforming the competition with DAC features such as ultra-low glitch, excellent INL, lowest power dissipation, an integrated reference with 0.004% initial accuracy and capability to source up to 20 mA at the VREFIN/VREFOUT pin, this family offers a powerful system solution. The DAC8568 family offers Binary Input and either Power-On-Reset to Zero or Mid-scale. These products are great for precision applications where high channel count, integration of features, small size and low power are paramount considerations.

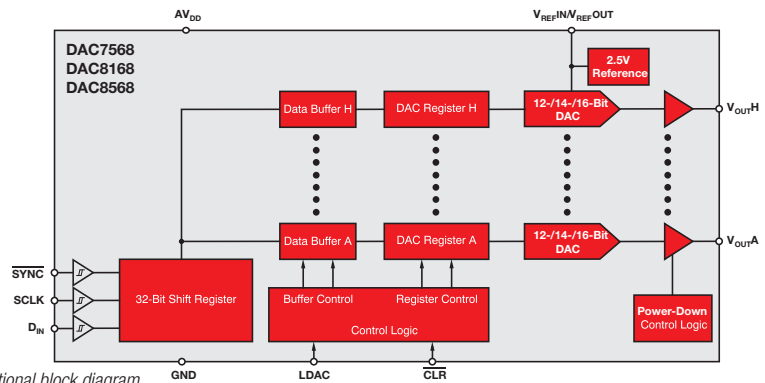

DAC8568 functional block diagram

➔ Digital-to-Analog Converters – String and R2R DACs

Precision DACs

Device	Res. (Bits)	No. of DAC Ch.	INL (max) (±LSB)	DNL (max) (±LSB)	Monotonic (Bits)	Settling Time (µs) (typ)	Interface	Power (mW) (typ)	Output Type	Output Range Programmability	Output (V/mA) (min)	Output (V/mA) (max)	V _{REF}	HiRel Avail.	Package(s)	Price*
Highest Accuracy, Low-Power DACs																
DAC9881	18	1	2	1	18	5	SPI™	6	Voltage	Fixed	0	5	Ext	N	QFN-24	16.90
DAC8814	16	4	1	1	16	0.5	SPI	0.027	Current	I _{OUT}	0	2	Ext	N	SSOP-28	16.95
DAC8734	16	4	1	1	16	6	SPI	—	Voltage	±V _{REF} , ±2V _{REF} , +2V _{REF} , +4V _{REF}	-16.5	20	Ext	N	QFN-40, TQFP-48	26.95
DAC8812	16	2	1	1	16	0.5	SPI	0.027	Current	I _{OUT}	0	2	Ext	N	TSSOP-16	8.40
DAC8822	16	2	1	1	16	0.5	P16	0.027	Current	I _{OUT}	0	2	Ext	N	TSSOP-18	8.65
DAC8811	16	1	1	1	16	0.5	SPI	0.027	Current	I _{OUT}	0	2	Ext	N	MSOP-8, SON-8	7.15
DAC8820	16	1	1	1	16	0.5	P16	0.027	Current	I _{OUT}	0	2	Ext	N	SSOP-28	8.50
DAC8830	16	1	1	1	16	1	SPI	0.015	Voltage	+V _{REF}	0	5	Ext	Y	SOIC-8	7.95
DAC8831	16	1	1	1	16	1	SPI	0.015	Voltage	+V _{REF} , ±V _{REF}	-5	5	Ext	Y	SOIC-14, QFN-14	7.95
DAC8832	16	1	1	1	16	1	SPI	0.015	Voltage	+V _{REF} , ±V _{REF}	-5	5	Ext	N	QFN-14	7.95
DAC8881	16	1	1	1	16	5	SPI	6	Voltage	Fixed	0	5	Ext	N	QFN-20	8.00
DAC8803	14	4	1	1	14	0.5	SPI	0.027	Current	I _{OUT}	0	2	Ext	N	SSOP-28	12.65
DAC8802	14	2	1	1	14	0.5	SPI	0.027	Current	I _{OUT}	0	2	Ext	N	TSSOP-16	6.10
DAC8805	14	2	1	1	14	0.5	P14	0.0027	Current	I _{OUT}	0	2	Ext	N	TSSOP-38	6.11
DAC8801	14	1	1	0.5	14	0.5	SPI	0.027	Current	I _{OUT}	0	2	Ext	N	MSOP-8, SON-8	4.60
DAC8806	14	1	1	1	14	0.5	P14	0.027	Current	I _{OUT}	0	2	Ext	N	SSOP-28	5.50
DAC8806	14	1	1	1	14	0.5	P14	0.027	Current	I _{OUT}	0	2	Ext	N	SSOP-28	5.50
Industrial, Bipolar-Output DACs																
DAC8718	16	8	4	1	16	10	SPI	165	Voltage	+6V _{REF} , ±3V _{REF}	-16.5	33	Ext	N	QFN-48, TQFP-64	21.95
DAC8728	16	8	4	1	16	10	P16	165	Voltage	+6V _{REF} , ±3V _{REF}	-16.5	33	Ext	N	QFN-56, TQFP-64	21.95
DAC8734	16	4	1	1	16	6	SPI	420	Voltage	±V _{REF} , ±2V _{REF} , +2V _{REF} , +4V _{REF}	-16.5	20	Ext	N	QFN-40, TQFP-48	26.95
DAC7734	16	4	2	2	16	10	SPI	50	Voltage	+V _{REFH} , -V _{REFL} to +V _{REFH}	-10	10	Ext	N	SSOP-48	31.45
DAC7744	16	4	2	1	16	10	P16	50	Voltage	+V _{REFH} , -V _{REFL} to +V _{REFH}	-10	10	Ext	N	SSOP-48	31.45
DAC7634	16	4	3	2	15	8	SPI	7.5	Voltage	+V _{REFH} , -V _{REFL} to +V _{REFH}	-2.5	2.5	Ext	N	SSOP-48	19.95
DAC7644	16	4	3	2	15	8	P16	7.5	Voltage	+V _{REFH} , -V _{REFL} to +V _{REFH}	-2.5	2.5	Ext	N	SSOP-48	19.95
DAC7654	16	4	3	1	16	12	SPI	18	Voltage	+2.5, ±2.5	-2.5	2.5	Int	N	LQFP-64	27.25
DAC7664	16	4	3	3	16	12	P16	18	Voltage	+2.5, ±2.5	-2.5	2.5	Int	N	LQFP-64	25.95
DAC8812	16	2	1	1	16	0.5	SPI	0.027	Current	I _{OUT}	0	2	Ext	N	TSSOP-16	8.40
DAC8822	16	2	1	1	16	0.5	P16	0.027	Current	I _{OUT}	0	2	Ext	N	TSSOP-38	8.65
DAC7642	16	2	3	2	15	8	P16	2.5	Voltage	+V _{REFH} , -V _{REFL} to +V _{REFH}	-2.5	2.5	Ext	N	LQFP-32	13.19
DAC7643	16	2	3	2	15	8	P16	2.5	Voltage	+V _{REFH} , -V _{REFL} to +V _{REFH}	-2.5	2.5	Ext	N	LQFP-32	13.19
DAC7632	16	2	3	2	15	8	SPI	2.5	Voltage	+V _{REFH} , -V _{REFL} to +V _{REFH}	-2.5	2.5	Ext	N	LQFP-32	10.45
DAC8811	16	1	1	1	16	0.5	SPI	0.027	Current	I _{OUT}	0	2	Ext	N	MSOP-8, SON-8	7.15
DAC8820	16	1	1	1	16	0.5	P16	0.027	Current	I _{OUT}	0	2	Ext	N	SSOP-28	8.50
DAC8871	16	1	1	1	16	1	SPI	0.015	Voltage	-V _{REFL} to +V _{REFH}	-18	18	Ext	N	SOIC-14	8.00
DAC714	16	1	1	1	16	6	SPI	525	Voltage	+10, ±5, ±10	-10	10	Int	N	SOIC-16	14.50
DAC712	16	1	2	1	16	6	P16	525	Voltage	±10	-10	10	Int	N	SOIC-28, PDIP-28	14.50
DAC7731	16	1	3	3	16	5	SPI	100	Voltage	+10, ±5, ±10, +V _{REF}	-10	10	Int/Ext	N	SSOP-24	8.20
DAC7742	16	1	3	1	16	5	P16	100	Voltage	+10, ±5, ±10, +V _{REF}	-10	10	Int/Ext	N	LQFP-48	10.88

*Suggested resale price in U.S. dollars in quantities of 1,000. See www.ti.com/hirel for HiRel options.

New products are listed in bold red.

➔ Digital-to-Analog Converters – String and R2R DACs

Precision DACs (continued)

Device	Res. (Bits)	No. of DAC Ch.	INL (max) (±LSB)	DNL (max) (±LSB)	Mono-tonic (Bits)	Settling Time (µs) (typ)	Interface	Power (mW) (typ)	Output Type	Output Range Programmability	Output (V/mA) (min)	Output (V/mA) (max)	V _{REF}	HiRel Avail.	Package(s)	Price*
Industrial, Bipolar-Output DACs (continued)																
DAC7741	16	1	3	1	16	5	P16	100	Voltage	+10, ±5, ±10, +V _{REF}	-10	10	Int/Ext	N	LQFP-48	8.30
DAC7641	16	1	3	2	15	8	P16	1.8	Voltage	-V _{REFL} to +V _{REFH}	-2.5	2.5	Ext	N	TQFP-32	7.88
DAC7631	16	1	3	2	15	8	SPI	1.8	Voltage	-V _{REFL} to +V _{REFH}	-2.5	2.5	Ext	N	SSOP-20	5.95
DAC8580	16	1	64	1	16	0.35	SPI	200	Voltage	±V _{REF}	-5.5	5.5	Ext	N	TSSOP-16	1.85
DAC8581	16	1	64	0.5	16	0.35	SPI	200	Voltage	±V _{REF}	-5.5	5.5	Ext	N	TSSOP-16	1.85
DAC8228	14	8	2	1	14	10	P14	107	Voltage	+6V _{REF} ±3V _{REF}	-16.5	33	Ext	N	QFN-56, TQFP-64	17.95
DAC8218	14	8	2	1	14	10	SPI	115	Voltage	+6V _{REF} ±3V _{REF}	-16.5	33	Ext	N	QFN-48, TQFP-64	17.95
DAC8803	14	4	1	1	14	0.5	SPI	0.027	Current	I _{OUT}	0	2	Ext	N	SSOP-28	12.65
DAC8234	14	4	1	1	14	6	SPI	165	Voltage	±V _{REF} ±2V _{REF} , +2V _{REF} +4V _{REF}	-16.5	20	Ext	N	QFN-48, TQFP-64	19.95
DAC8802	14	2	1	1	14	0.5	SPI	0.027	Current	I _{OUT}	0	2	Ext	N	TSSOP-16	6.10
DAC8805	14	2	1	1	14	0.5	P14	0.0027	Current	I _{OUT}	0	2	Ext	N	TSSOP-38	6.11
DAC8801	14	1	1	0.5	14	0.5	SPI	0.027	Current	I _{OUT}	0	2	Ext	N	MSOP-8, SON-8	4.60
DAC8806	14	1	1	1	14	0.5	P14	0.027	Current	I _{OUT}	0	2	Ext	N	SSOP-28	5.50
DAC7728	12	8	1	1	12	10	P12	107	Voltage	+6V _{REF} ±3V _{REF}	-16.5	33	Ext	N	QFN-56, TQFP-64	11.95
DAC7718	12	8	1	1	12	10	SPI	165	Voltage	+6V _{REF} ±3V _{REF}	-16.5	33	Ext	N	QFN-48, TQFP-64	11.95
DAC7716	12	4	1	1	12	6	SPI	420	Voltage	±V _{REF} ±2V _{REF} , +2V _{REF} +4V _{REF}	-16	20	Ext	N	QFN-40, TQFP-48	10.95
DAC7614	12	4	1	1	12	5	SPI	15	Voltage	-V _{REFL} to +V _{REFH}	-2.5	2.5	Ext	N	SOIC-16, SSOP-20	6.70
DAC7615	12	4	1	1	12	5	SPI	15	Voltage	-V _{REFL} to +V _{REFH}	0	2.5	Ext	N	SOIC-16, SSOP-20	6.70
DAC7616	12	4	1	1	12	5	SPI	2.4	Voltage	-V _{REFL} to +V _{REFH}	0	1.25	Ext	N	SOIC-16, SSOP-20	5.40
DAC7617	12	4	1	1	12	5	SPI	2.4	Voltage	-V _{REFL} to +V _{REFH}	0	1.25	Ext	N	SOIC-16, SSOP-20	5.40
DAC7624	12	4	1	1	12	5	P12	15	Voltage	+V _{REFH} , -V _{REFL} to +V _{REFH}	-2.5	2.5	Ext	N	PDIP-28, SOIC-28	9.75
DAC7625	12	4	1	1	12	5	P12	15	Voltage	+V _{REFH} , -V _{REFL} to +V _{REFH}	-2.5	2.5	Ext	N	PDIP-28, SOIC-28	9.75
DAC7714	12	4	1	1	12	8	SPI	45	Voltage	-V _{REFL} to +V _{REFH}	-10	10	Ext	N	SOIC-16	11.45
DAC7715	12	4	1	1	12	8	SPI	45	Voltage	-V _{REFL} to +V _{REFH}	-10	10	Ext	N	SOIC-16	11.45
DAC7724	12	4	1	1	12	8	P12	45	Voltage	-V _{REFL} to +V _{REFH}	-10	10	Ext	N	PLCC-28, SOIC-28	11.85
DAC7725	12	4	1	1	12	8	P12	45	Voltage	-V _{REFL} to +V _{REFH}	-10	10	Ext	N	PLCC-28, SOIC-28	11.85
DAC7800	12	2	0.5	1	12	0.4	SPI	1	Current	I _{OUT}	0	1	Ext	N	PDIP-16, SOIC-16	13.55
DAC7801	12	2	0.5	1	12	0.4	P(8+4)	1	Current	I _{OUT}	0	1	Ext	N	PDIP-24, SOIC-24	20.94
DAC7802	12	2	0.5	1	12	0.4	P12	1	Current	I _{OUT}	0	1	Ext	N	PDIP-24, SOIC-24	14.00
DAC7822	12	2	1	1	12	0.2	P12	0.027	Current	I _{OUT}	0	1	Ext	N	QFN-40	3.80
DAC811	12	1	0.25	0.5	12	3	P12	625	Voltage	+10, ±5, ±10	-10	10	Int	N	CDIP SB-28, SOIC-28	11.00
DAC813	12	1	0.25	0.5	12	3	P12	270	Voltage	+10, ±5, ±10, +V _{REF}	-10	10	Int/Ext	N	PDIP-28, SOIC-28	12.60
DAC7811	12	1	1	1	12	0.2	SPI	0.025	Current	I _{OUT}	0	1	Ext	N	MSOP-10, SON-10	2.55

*Suggested resale price in U.S. dollars in quantities of 1,000.

New products are listed in bold red.

Data Converters

➔ Digital-to-Analog Converters – String and R2R DACs

Precision DACs (continued)

Device	Res. (Bits)	No. of DAC Ch.	INL (max) (±LSB)	DNL (max) (±LSB)	Mono-tonic (Bits)	Settling Time (µs) (typ)	Interface	Power (mW) (typ)	Output Type	Output Range Programmability	Output (V/mA) (min)	Output (V/mA) (max)	V _{REF}	HiRel Avail.	Package(s)	Price*
Industrial, Bipolar-Output DACs (continued)																
DAC7821	12	1	1	1	12	0.2	P12	0.027	Current	I _{OUT}	0	1	Ext	N	QFN-20, TSSOP-20	2.60
DAC8043	12	1	1	1	12	0.25	SPI	2.5	Current	I _{OUT}	0	1	Ext	N	SOIC-8	3.60
DAC7613	12	1	1	1	12	5	P12	1.8	Voltage	+V _{REFH} , -V _{REFL} to +V _{REFH}	-2.5	2.5	Ext	N	SSOP-24	2.50
TLC7528	8	2	0.5	0.5	8	0.1	P8	7.5	Current	I _{OUT}	-10	10	Ext	N	SOIC-20, TSSOP-20	1.77
TLC7628	8	2	0.5	0.5	8	0.1	P8	20	Current	I _{OUT}	-10	10	Ext	N	SOIC-20, PDIP-20	1.91
TLC7524	8	1	0.5	0.5	8	0.1	P8	5	Current	I _{OUT}	-10	10	Ext	N	SOIC-16, TSSOP-16	1.55
Low-Power, Single-Supply DACs																
DAC8568	16	8	12	1	16	5	SPI	1.8	Voltage	+V _{REF} , +2V _{REF}	0	5	Int/Ext	N	TSSOP-16	10.95
DAC8564	16	4	8	1	16	8	SPI	2.6	Voltage	+V _{REF}	0	5	Int/Ext	N	TSOP-16	7.65
DAC8565	16	4	8	1	16	8	SPI	2.6	Voltage	+V _{REF}	0	5	Int/Ext	N	TSSOP-16	7.65
DAC8554	16	4	12	1	16	8	SPI	1.6	Voltage	+V _{REFH}	0	5	Ext	N	TSSOP-16	6.72
DAC8555	16	4	12	1	16	8	SPI	1.6	Voltage	+V _{REFH}	0	5	Ext	N	TSSOP-16	6.72
DAC8534	16	4	64	1	16	8	SPI	2.7	Voltage	+V _{REFH}	0	5	Ext	N	TSSOP-16	8.75
DAC8574	16	4	64	1	16	8	I ² C	2.4	Voltage	+V _{REFH}	0	5	Ext	N	TSSOP-16	12.85
DAC8544	16	4	65	1	16	8	P16	2.6	Voltage	+V _{REFH}	0	5	Ext	N	TQFP-48	12.20
DAC8552	16	2	8	1	16	8	SPI	0.8	Voltage	+V _{REFH}	0	5	Ext	N	MSOP-8	3.20
DAC8562	16	2	12	1	16	5	SPI	0.5	Voltage	+2.5, +5, +V _{REF}	0	5	Int/Ext	N	QFN-10, MSOP-10	3.40
DAC8532	16	2	65	1	16	8	SPI	1.35	Voltage	+V _{REF}	0	5	Ext	N	MSOP-8	5.35
DAC715	16	1	2	1	16	6	P16	525	Voltage	Fixed	0	10	Int	N	PDIP-28, SOIC-28	19.85
DAC716	16	1	2	2	16	6	SPI	525	Voltage	Fixed	0	10	Int	N	PDIP-16, SOIC-16	19.85
DAC8411	16	1	8	2	16	6	SPI	0.1	Voltage	+AV _{DD}	0	5	Ext	N	SC70-6	2.90
DAC8550	16	1	8	1	16	8	SPI	0.4	Voltage	+V _{REF}	0	5	Ext	N	MSOP-8	2.60
DAC8551	16	1	8	1	16	8	SPI	0.4	Voltage	+V _{REF}	0	5	Ext	N	MSOP-8	2.60
DAC8560	16	1	8	1	16	8	SPI	1.4	Voltage	+2.5, +V _{REF}	0	5	Int/Ext	N	MSOP-8	2.88
DAC8501	16	1	64	1	16	8	SPI	0.6	Voltage	V _{+REF}	0	5	Ext	N	MSOP-8	2.97
DAC8531	16	1	64	1	16	8	SPI	0.6	Voltage	V _{+REF}	0	5	Ext	N	MSOP-8, SON-8	2.97
DAC8541	16	1	65	1	16	8	P16	0.6	Voltage	V _{+REF}	0	5	Ext	N	TQFP-32	3.00
DAC8571	16	1	65	1	16	8	I ² C	0.4	Voltage	V _{+REF}	0	5	Ext	N	MSOP-8	2.95
DAC8168	14	8	4	0.5	14	5	SPI	1.8	Voltage	+V _{REF} , +2V _{REF}	0	5	Int/Ext	N	TSSOP-16, TSSOP-14	10.20
DAC8164	14	4	2	1	14	8	SPI	2.6	Voltage	+V _{REF}	0	5	Int/Ext	N	TSSOP-16	6.85
DAC8165	14	4	2	1	14	8	SPI	2.6	Voltage	+V _{REF}	0	5	Int/Ext	N	TSSOP-16	6.85
DAC8162	14	2	3	0.5	14	5	SPI	0.5	Voltage	+2.5, +5, +V _{REF}	0	5	Int/Ext	N	QFN-10, MSOP-10	2.50
DAC8311	14	1	4	1	14	6	SPI	0.1	Voltage	+AV _{DD}	0	5	Ext	N	SC70-6	2.45
DAC7558	12	8	1	0.5	12	5	SPI	2.7	Voltage	+V _{REF}	0	5	Ext	N	QFN-32	7.50
DAC7568	12	8	1	0.25	12	5	SPI	1.8	Voltage	+V _{REF} , +2V _{REF}	0	5	Int/Ext	N	Int/Ext	8.20
DAC7678	12	8	1	0.25	12	6	I ² C	2.3	Voltage	+2.5, +V _{REF}	0	5	Int/Ext	N	Int/Ext	6.00
DAC7578	12	8	1	0.25	12	6	I ² C	2.3	Voltage	+V _{REF}	0	5	Ext	N	Ext	5.50

*Suggested resale price in U.S. dollars in quantities of 1,000.

New products are listed in bold red.

➔ Digital-to-Analog Converters – String and R2R DACs

Precision DACs (continued)

Device	Res. (Bits)	No. of DAC Ch.	INL (max) (±LSB)	DNL (max) (±LSB)	Mono-tonic (Bits)	Settling Time (µs) (typ)	Interface	Power (mW) (typ)	Output Type	Output Range Programmability	Output (V/mA) (min)	Output (V/mA) (max)	V _{REF}	HiRel Avail.	Package(s)	Price*
Low-Power, Single-Supply DACs (continued)																
TLV5610	12	8	6	1	12	1	SPI	18	Voltage	+V _{REF}	0	5	Ext	N	SOIC-20, TSSOP-20, CSP-20	10.65
TLV5630	12	8	6	1	12	1	SPI	18	Voltage	+2.048,+4.096,+2V _{REF}	0	5	Int/Ext	N	SOIC-20, TSSOP-20	11.06
DAC7564	12	4	1	0.5	12	8	SPI	2.9	Voltage	+V _{REF}	0	5	Int/Ext	N	TSSOP-16	4.00
DAC7565	12	4	1	0.5	12	8	SPI	2.9	Voltage	+V _{REF}	0	5	Int/Ext	N	TSSOP-16	4.00
DAC7554	12	4	1	0.5	12	5	SPI	1.5	Voltage	+V _{REF}	0	5	Ext	N	MSOP-10	4.80
TLV5614	12	4	4	1	12	3	SPI	3.6	Voltage	+V _{REF}	0	5	Ext	Y	SOIC-16, TSSOP-16, CSP-16	10.00
DAC7573	12	4	8	1	12	8	I ² C	1.5	Voltage	+V _{REF}	0	5	Ext	N	TSSOP-16	7.65
DAC7574	12	4	8		12	8	I ² C	1.5	Voltage	+V _{REF}	0	5	Ext	N	MSOP-10	6.12
DAC7562	12	2	0.75	0.25	12	5	SPI	0.5	Voltage	+2.5,+5,+V _{REF}	0	5	Int/Ext	N	QFN-10, MSOP-10	2.05
DAC7552	12	2	1	0.5	12	5	SPI	0.7	Voltage	+V _{REF}	0	5	Ext	N	QFN-16	2.35
DAC7553	12	2	1	0.5	12	5	SPI	0.7	Voltage	+V _{REF}	0	5	Ext	N	QFN-16	2.94
DAC7612	12	2	1	1	12	7	SPI	3.5	Voltage	Fixed	-2.5	2.5	Int	N	SOIC-8	3.10
TLV5638	12	2	4	1	12	1	SPI	4.5	Voltage	+V _{REF}	0	5	Int/Ext	Y	SOIC-8, CDIP-8, LCCC-20	4.65
TLV5618A	12	2	4	1	12	2.5	SPI	1.8	Voltage	+V _{REF}	0	5	Ext	Y	SOIC-8, LCCC-20	5.10
DAC7551	12	1	1	0.5	12	5	SPI	0.3	Voltage	+V _{REF}	0	5	Ext	N	SON-12	1.40
DAC7611	12	1	1	1	12	7	SPI	2.5	Voltage	Fixed	0	4.1	Int	N	SON-12	2.55
DAC7621	12	1	1	1	12	7	P12	2.5	Voltage	Fixed	-2.5	2.5	Int	N	SSOP-20	2.75
DAC7311	12	1	1	1	12	6	SPI	0.2	Voltage	+AV _{DD}	0	5	Ext	N	SC70-6	0.95
TLV5633	12	1	3	0.5	12	1	P8	2.7	Voltage	+V _{REF}	0	5	Int/Ext	N	SOIC-20, TSSOP-20	5.90
TLV5639	12	1	3	0.5	12	1	P12	2.7	Voltage	+V _{REF}	0	5	Int/Ext	N	SOIC-20, TSSOP-20	4.35
TLV5613	12	1	4	1	12	1	P8	1.2	Voltage	+V _{REF}	0	5	Ext	N	SOIC-20, TSSOP-20	3.30
TLV5619	12	1	4	1	12	1	P12	4.3	Voltage	+V _{REF}	0	5	Ext	Y	SOIC-20, TSSOP-20	4.10
TLV5636	12	1	4	1	12	1	SPI	4.5	Voltage	+V _{REF}	0	5	Int/Ext	N	SOIC-8, VSSOP-8	4.55
TLV5616	12	1	4	1	12	3	SPI	0.9	Voltage	+V _{REF}	0	5	Ext	N	VSSOP-8, SOIC-8	3.30
DAC7571	12	1	4		12	8	I ² C	0.3	Voltage	+V _{REF}	0	5	Ext	N	SOT-23-6	1.55
DAC7512	12	1	8	1	12	8	SPI	0.3	Voltage	+V _{REF}	0	5	Ext	N	MSOP-8, SOT-23-6	1.45
DAC7513	12	1	8	1	12	8	SPI	0.3	Voltage	+V _{REF}	0	5	Ext	N	MSOP-8, SOT-23-8	1.65
DAC6578	10	8	1	0.25	10	6	I ² C	2.3	Voltage	+V _{REF}	0	5	Ext	N	QFN-24, TSSOP-16	3.90
TLV5608	10	8	2	1	10	1	SPI	18	Voltage	+V _{REF}	0	5	Ext	N	SOIC-20, TSSOP-20, CSP-20	4.90
TLV5631	10	8	2	1	10	1	SPI	18	Voltage	+2.048,+4.096,+2V _{REF}	0	5	Int/Ext	N	SOIC-20, TSSOP-20	5.60
TLV5604	10	4	1	1	10	2.5	SPI	3	Voltage	+V _{REF}	0	5	Ext	N	SOIC-16, TSSOP-16	3.70
DAC6573	10	4	2	0.5	10	7	I ² C	1.5	Voltage	+V _{REF}	0	5	Ext	N	TSSOP-16	3.05
DAC6574	10	4	2	0.5	10	7	I ² C	1.5	Voltage	+V _{REF}	0	5	Ext	N	MSOP-10	3.85

*Suggested resale price in U.S. dollars in quantities of 1,000. See www.ti.com/hirel for HiRel options.

New products are listed in bold red.

➔ Digital-to-Analog Converters – String and R2R DACs

Precision DACs (continued)

Device	Res. (Bits)	No. of DAC Ch.	INL (max) (±LSB)	DNL (max) (±LSB)	Monotonic (Bits)	Settling Time (µs) (typ)	Interface	Power (mW) (typ)	Output Type	Output Range Programmability	Output (V/mA) (min)	Output (V/mA) (max)	V _{REF}	HiRel Avail.	Package(s)	Price*
Low-Power, Single-Supply DACs (continued)																
TLV5637	10	2	1	0.5	10	0.8	SPI	4.2	Voltage	+V _{REF}	0	5	Int/Ext	N	SOIC-8	3.95
TLV5617A	10	2	1	0.5	10	1	SPI	1.8	Voltage	+V _{REF}	0	5	Ext	N	SOIC-8	2.25
DAC6311	10	1	0.5	0.5	10	6	SPI	0.2	Voltage	+AV _{DD}	0	5	Ext	N	SC70-6	0.65
TLC5615	10	1	1	0.5	10	12.5	SPI	0.8	Voltage	+V _{REF}	0	5	Ext	N	PDIP-8, SOIC-8	1.90
TLV5606	10	1	1.5	1	10	3	SPI	0.9	Voltage	+V _{REF}	0	5	Ext	N	SOIC-8, MSOP-8	1.30
DAC6571	10	1	2	0.5	10	7	I ² C	0.5	Voltage	+V _{REF} , 2V _{REF}	0	5	Ext	N	SOT-23-6	1.40
TLV5629	8	8	1	1	8	1	SPI	18	Voltage	+V _{REF} , +2V _{REF}	0	5	Ext	N	SOIC-20, TSSOP-20	3.15
TLV5632	8	8	1	1	8	1	SPI	18	Voltage	+2.048, +4.096, +2V _{REF}	0	5	Int/Ext	N	SOIC-20, TSSOP-20	4.20
TLC5628	8	8	1	0.9	8	10	SPI	15	Voltage	+V _{REF}	0	5	Ext	N	PDIP-16, SOIC-16	2.45
TLV5628	8	8	1	0.9	8	10	SPI	12	Voltage	+V _{REF}	0	5	Ext	N	PDIP-16, SOIC-16	2.20
DAC5578	8	8	1	0.25	8	6	I ² C	2.3	Voltage	+V _{REF}	0	5	Ext	N	QFN-24, TSSOP-16	3.00
TLV5627	8	4	0.5	0.5	8	2.5	SPI	3	Voltage	+V _{REF}	0	5	Ext	N	SOIC-16, TSSOP-16	2.05
DAC5573	8	4	0.5	0.25	8	6	I ² C	1.5	Voltage	+V _{REF}	0	5	Ext	N	TSSOP-16	2.55
DAC5574	8	4	0.5	0.25	8	6	I ² C	1.5	Voltage	+V _{REF}	0	5	Ext	N	MSOP-10	2.55
TLC7225	8	4	1	1	8	5	P8	75	Voltage	+V _{REF}	-5	10	Ext	N	SOIC-24	2.35
TLC7226	8	4	1	1	8	5	P8	90	Voltage	+V _{REF}	-5	10	Ext	Y	PDIP-20, SOIC-20	2.15
TLC5620	8	4	1	0.9	8	10	SPI	8	Voltage	+V _{REF} , +2V _{REF}	0	5	Ext	N	PDIP-14, SOIC-14	1.75
TLV5620	8	4	1	0.9	8	10	SPI	6	Voltage	+V _{REF} , +2V _{REF}	0	5	Ext	N	PDIP-14, SOIC-14	1.00
TLV5621	8	4	1	0.9	8	10	SPI	3.6	Voltage	+V _{REF} , +2V _{REF}	0	5	Ext	N	SOIC-14	2.10
TLV5625	8	2	0.5	0.2	8	3	SPI	2.4	Voltage	+V _{REF}	0	5	Ext	N	SOIC-8	1.70
TLV5626	8	2	1	0.5	8	0.8	SPI	4.2	Voltage	+V _{REF}	0	5	Int/Ext	N	SOIC-8	1.90
DAC5311	8	1	0.25	0.25	8	6	SPI	0.2	Voltage	+AV _{DD}	0	5	Ext	Y	SC70-6	0.55
TLV5624	8	1	0.5	0.2	8	1	SPI	5	Voltage	+V _{REF}	0	5	Int/Ext	N	SOIC-8, MSOP-8	1.60
TLV5623	8	1	0.5	0.2	8	3	SPI	2.1	Voltage	+V _{REF}	0	5	Ext	N	SOIC-8, MSOP-8	0.99
DAC5571	8	1	1	0.25	8	6	I ² C	0.3	Voltage	+V _{REF}	0	5	Ext	N	SOT-23-6	0.90

*Suggested resale price in U.S. dollars in quantities of 1,000. See www.ti.com/hirel for HiRel options.

New products are listed in bold red.

Digital-to-Analog Converters – Current Steering DACs

Dual-Channel, 16-Bit, 800MSPS, Digital-to-Analog Converter (DAC)

DAC3282, DAC3283

Get samples and datasheets at: www.ti.com/sc/device/DAC3282 and www.ti.com/sc/device/DAC3283

Key Features

- Dual, 16-bit, 800MSPS DACs
- DAC3283: Single-carrier TM1 WCDMA ACLR: 82dBc at $f_{OUT} = 122.88\text{MHz}$
- 8-bit input LVDS data bus
 - Byte-wide interleaved data load
 - 8 sample input FIFO
 - Optional data pattern checker
- Multi-DAC synchronization
- Selectable 2x-4x interpolation filters
 - Stop-band attenuation >85dB
- $F_s/2$ and $\pm F_s/4$ coarse mixer
- Digital quadrature modulator correction
 - Gain, phase and offset control
- Temperature sensor
- 3- or 4-wire serial control interface
- On-chip 1.2-V reference
- Differential scalable output: 2 to 20mA
- Low power: 1.3W at 800MSPS
- Space saving package: 48-pin 7mmx7mm QFN

Applications

- Wireless communications
 - 3G/4G macro base stations
 - Wideband repeaters
 - Software-defined radios
 - Diversity transmitters
- Test and measurement – ARB
- 802.16d/e
- Power amplifier linearization

The 650MSPS DAC3282 and 800MSPS DAC3283 were designed to provide a dual DAC solution for driving high-performance I/Q modulators (like the TRF3703) in as small a package as possible with a minimal I/O count. The DACs were also designed to cover the very popular wireless infrastructure DAC Sample-Rates of 491.52, 614.40 and 737.28MSPS. By using only 8 LVDS I/O pairs and residing in a 7mm x 7mm 48-pin QFN package, the DAC3282 and DAC3283 reduce the number of input traces by half and reduce board space by as much as 80% (comparable to 100-pin TQFP vs. an 80-pin TQFP, the DACs reduce space by 75%; vs. 64-pin QFN it saves 40%). The DAC3282 provides a 2x interpolation filter with a baseband-optimized sinc correction filter. The DAC3283 provides 2x and 4x interpolation filters along with a higher sample-rate, but does not include the sinc correction filter. By providing 81dBc ACLR at 153MHz IF, the DAC3283 is also optimized for mid and high IF transmit solutions, whereas the DAC3282 is optimized for low IF and baseband transmit chains.

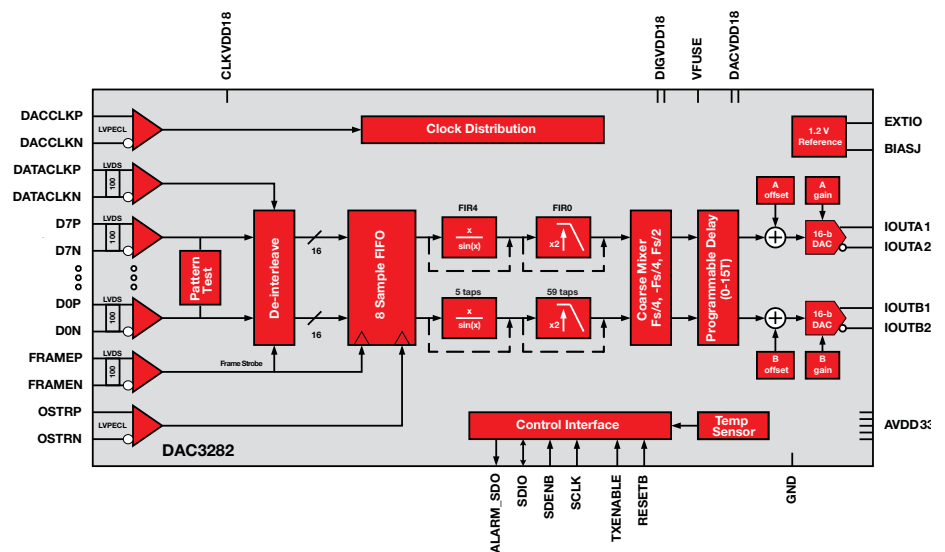

DAC3282 functional block diagram

➔ Digital-to-Analog Converters – Current Steering DACs

Current Steering DACs

Device	Res. (Bits)	Supply (V)	Update Rate (MSPS)	Settling Time (ns)	Number of DACs	Power (mW) (typ)	DNL (\pm LSB) (max)	INL (\pm LSB) (max)	HiRel Avail.	Package(s)	Price*
DAC5681	16	1.8/3.3	1000	10.4	1	650	2	4	N	QFN-64	27.50
DAC5681Z	16	1.8/3.3	1000	10.4	1	800	2	4	N	QFN-64	30.95
DAC5682Z	16	1.8/3.3	1000	10.4	2	1300	2	4	N	QFN-64	31.95
DAC5688	16	1.8/3.3	800	11	2	1750	2	4	N	QFN-64	29.95
DAC5689	16	1.8/3.3	800	11	2	1750	2	4	N	QFN-64	28.95
DAC3283	16	1.8/3.3	800	10.4	2	1150	2	4	N	QFN-48	26.95
DAC3282	16	1.8/3.3	625	10.4	2	950	2	4	N	QFN-48	24.95
DAC5687	16	1.8/3.3	500	12	2	750	4	4	Y	HTQFP-100	22.50
DAC5686	16	1.8/3.3	500	12	2	450	9	12	N	HTQFP-100	19.75
DAC5670	14	1.8/3.3	2400	—	1	2000	0.8	1.5	Y	BGA-252	45.00
DAC3172	14	1.8/3.3	500	—	2	300	0.5	1	N	QFN-48	15.95
DAC5675	14	3	400	5	1	820	2	4	Y	HTQFP-48	29.45
DAC5672A	14	3.0 to 3.6	275	20	2	330	3	4	Y	TQFP-48	13.25
DAC904	14	3.0 to 5.0	165	30	1	170	1.75	2.5	N	SOP-28, TSSOP-28	6.25
DAC2904	14	3.3 to 5.0	125	30	2	310	4	5	N	TQFP-48	20.19
DAC3162	12	1.8/3.3	500	—	2	300	0.25	0.5	N	QFN-48	12.60
DAC5674	12	1.8/3.3	400	20	1	420	2	3.5	N	HTQFP-48	15.00
DAC5662A	12	3.0 to 3.6	275	20	2	330	2	2	Y	TQFP-48	10.70
DAC902	12	3.0 to 5.0	165	30	1	170	1.75	2.5	N	SOP-28, TSSOP-28	6.25
THS5661A	12	3.0 to 5.0	125	35	1	175	2	4	N	SOP-28, TSSOP-28	6.25
DAC2902	12	3.3 to 5.5	125	30	2	310	2.5	3	N	TQFP-48	15.41
DAC2932	12	2.7 to 3.3	40	25	2	29	0.5	2	N	TQFP-48	7.95
DAC3152	10	1.8/3.3	500	—	2	300	0.1	0.25	N	QFN-48	9.15
DAC5652A	10	3.0 to 3.6	275	20	2	290	1	0.5	Y	TQFP-48	7.60
DAC900	10	3.0 to 5.0	165	30	1	170	0.5	1	Y	SOP-28, TSSOP-28	4.25
THS5651A	10	3.0 to 5.0	125	35	1	175	0.5	1	N	SOP-28, TSSOP-28	4.25
DAC2900	10	3.3 to 5.5	125	30	2	310	1	1	N	TQFP-48	6.00
DAC908	8	3.0 to 5.0	165	30	1	170	0.5	0.5	N	SOP-28, TSSOP-28	2.90
THS5641A	8	3.0 to 5.0	100	35	1	100	0.5	1	N	SOP-28, TSSOP-28	2.90
TLC5602	8	4.75 to 5.25	30	30	1	80	0.5	0.5	N	SOP-20	1.55

*Suggested resale price in U.S. dollars in quantities of 1,000. See www.ti.com/hirel for HiRel options.

New products are listed in **bold red**. Preview products are listed in **bold blue**.

➔ Digital-to-Analog Converters – Digital Potentiometers

256-Tap Dual Potentiometer with I²C Interface in Industry's Smallest Package

TPL0102

PREVIEW*

Contact your TI sales representative for more information.

Key Features

- Accuracy and speed
 - Low temp coefficient: 35ppm/°C
 - ±20% resistance tolerance
 - Fast power-up response time to wiper setting: <300µs
- Usage flexibility
 - Programmable nonvolatile memory
 - 2.7V to 5.5V single-supply operation
 - ±2.25V to ±2.75V dual-supply operation
 - 10kΩ, 50kΩ, 100kΩ end-to-end resistance
 - Operating temperature -40°C to +85°C
- Industry's smallest package
 - 14-pin microQFN (2 x 2 mm)
 - 14-pin TSSOP

Applications

- Adjustable power supplies
- Adjustable gain amps and offset trimming
- Precision calibration of set point thresholds
- Sensor trimming and calibration
- Mechanical potentiometer replacement

The TPL0102 is a two channel, linear-taper digital potentiometer with 256 wiper positions. Each potentiometer can be used as a three-terminal potentiometer or as a two-terminal rheostat. The TPL0102 is offered with three different values of end-to-end resistances: 10kΩ, 50kΩ, and 100kΩ. It has non-volatile memory which can be used to store the wiper position which is loaded within 300µs after power up. The internal registers of the TPL0102 can be accessed using the I²C interface. The TPL0102 has a nominal temperature coefficient of 35ppm/°C. It is available in industry's smallest 14-pin microQFN as well as 14-pin TSSOP package with a specified temperature range of -40°C to +85°C.

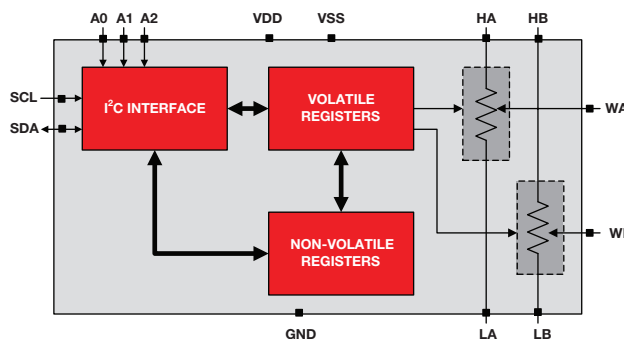

TPL0102 functional block diagram

*Expected release date: Q1 2011

256-Tap Dual Potentiometer with SPI™ Interface in Industry's Smallest Package

TPL0202

PREVIEW*

Contact your TI sales representative for more information.

Key Features

- Accuracy and speed
 - Low temp coefficient: 35ppm/°C
 - ±20% resistance tolerance
 - Fast power-up response time to wiper setting: <300µs
- Usage flexibility
 - Programmable nonvolatile memory
 - 2.7V to 5.5V single-supply operation
 - ±2.25 V to ±2.75V dual-supply operation
 - 10kΩ, 50kΩ, 100kΩ end-to-end resistance
 - Operating temperature -40°C to +85°C
- Industry's smallest package
 - 14-pin microQFN (2 x 2 mm)
 - 16-pin QFN

Applications

- Adjustable power supplies
- Adjustable gain amps and offset trimming
- Precision calibration of set point thresholds
- Sensor trimming and calibration
- Mechanical potentiometer replacement

The TPL0202 is a two channel, linear-taper digital potentiometer with 256 wiper positions. Each potentiometer can be used as a three-terminal potentiometer or as a two-terminal rheostat. The TPL0202 is offered with three different values of end-to-end resistances: 10kΩ, 50kΩ, and 100kΩ. It has non-volatile memory which can be used to store the wiper position which is loaded within 300µs after power up. The internal registers of the TPL0202 can be accessed using the SPI™ interface. The TPL0102 has a nominal temperature coefficient of 35ppm/°C. It is available in industry's smallest 14-pin microQFN as well as 16-pin QFN package with a specified temperature range of -40°C to +85°C.

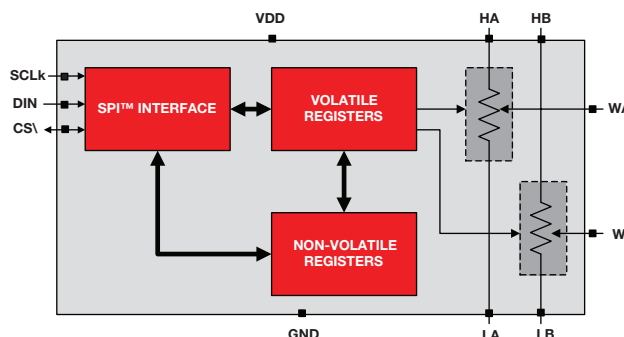

TPL0202 functional block diagram

*Expected release date: Q2 2011

→ Integrated ADCs and DACs

12-Bit Analog Monitoring and Control Solution

AMC7824



Get samples, datasheets and EVMs at: www.ti.com/sc/device/AMC7824

Key Features

- High integration
 - Four 12-bit DACs with programmable outputs
 - 8 channel, 500ksps, 12-bit ADC
 - Two remote and 1 local temp. sensors
 - Internal precision reference 2.5V
- Smart and easy control with EE port and look up tables
 - Auto down-load of ADC, DAC and temp sense parameters from external EEPROM with EE Port via I²C
 - Internal look-up tables eliminate the need for local microcontroller
- Wide temp range: -40°C to 105°C
- Packages: 48-pin QFN (6x6), 48-pin TQFP (7x7)

Applications

- RF PA control
- Base station systems
- Industrial control
- Optical control
- General purpose analog and monitoring

The AMC7824 is a complete analog monitoring and control circuit including 8-channel, 12-bit ADC, four 12-bit DACs, four out-of-range alarms, plus intelligent control for user defined adjustments. Internal sensors monitor chip temperature, and up to two remote sensor diode temperatures. The AMC7824 is ideal for multi-channel applications where low power and small size are critical and is available in 48-lead QFN and 48-lead TQFP packages and is fully specified over the -40°C to +105°C temperature range.

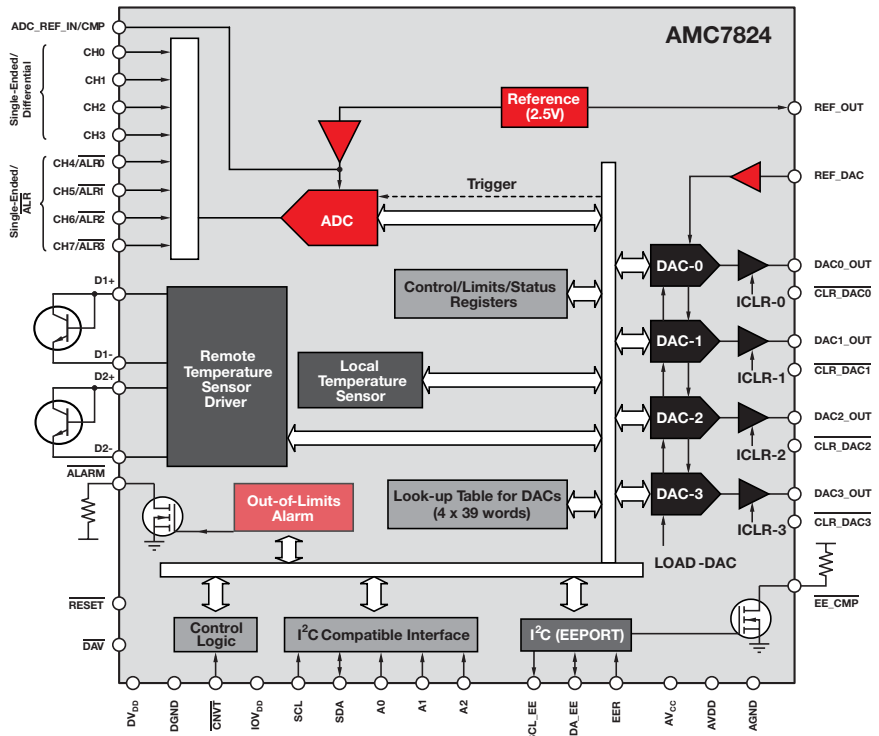

AMC7824 functional block diagram

Integrated ADCs and DACs: Analog Monitoring and Control Devices

Device	ADC/ DAC Res (Bits)	No. ADC Inputs	No. DAC Outputs	ADC Sample-Rate (Ksps)	ADC Input Range (V)	DAC Output Voltage - (max) (V)	Number of Local and Remote Temp Sensors	No. of GPIOs	Interface	Additional Features	HiRel Avail.	Package(s)	Price*
AMC7820	12	8 SE	3	100	0 to 5	+5V	None/None	None	SPI™	9 Op Amps, Thermistor Current Source	N	TQFP-48	4.70
AMC7823	12	8 SE	8	200	0 to 5	+5V	1/None	6	SPI	Precision Current Source	N	QFN-40	6.00
AMC7812	12	(16 SE) or (12 SE, 2DE)	12	500	-5 to 5	+5V/+12.5V	1/2	8	SPI or I ² C	Out-of-Range Alarms	N	QFN-64	9.95
AMC7824	12	(8 SE) or (4SE, 2DE)	4	500	-5 to 5	+5V/+12.5V	1/2	None	I ² C	Lookup Tables, EEPROM Port	N	QFN-48, TQFP-48	6.00
AMC7891	10	8 SE	4	500	-5.5 to 5.5	+5V	1/None	12	SPI	Out-of-Range Alarms	N	QFN-36	4.50

*Suggested resale price in U.S. dollars in quantities of 1,000. All parts have a built-in internal reference.

New products are listed in bold red. Preview products are listed in bold blue.

→ Audio Converters

Very Low-Power Stereo Codec with miniDSP and DirectPath™ HP Amplifier

TLV320AIC3256

NEW

Get samples, datasheets and application reports at: www.ti.com/sc/device/TLV320AIC3256

Key Features

- PowerTune™ technology adjustable power vs. SNR (stereo, 48Ksps):
 - DAC: 5mW at 84dB → TBDdB at TBDmW
 - ADC: 5mW at 86dB → 16mW at 93dB
- Analog and digital mic support (PDM format)
- Embedded miniDSP
- Integrated DirectPath™ stereo headphones driver
- Integrated LDOs allow single-supply operation (1.65V – 1.95V)

Applications

- Cell phones
- Portable navigation devices (PND)
- MP3 players
- Portable media player (PMP)
- Headsets

The TLV320AIC3256 is a very flexible low-power and low-voltage stereo audio CODEC with integrated miniDSP. The miniDSP can run advanced audio processing algorithms, like echo and noise cancellation, while offloading the host processor. The AIC3254 supports PowerTune™ technology, which lets the user set the power consumption vs. SNR trade-off under any usage case. It also integrates an LDO that allows single-supply operation (1.9V to 3.6V). It accepts voltages down to 1.5V (1.1V for the digital I/O) and its extreme low-power consumption (4.1mW stereo playback) extends battery life in portable applications. Digital microphone support is also provided for improved system level noise immunity. Additionally, it has a PLL that accepts any input clock between 512kHz to 50MHz and has excellent SNR and THD performance. Amplifier functionality such as mic bias, pre-amp and stereo headphone drivers are integrated in the codec to reduce solution size and parts count. With integrated DirectPath™ technology, amps have DC bias at 0V, so the DC blocking caps can be removed, resulting in a smaller solution with better low-frequency audio response.

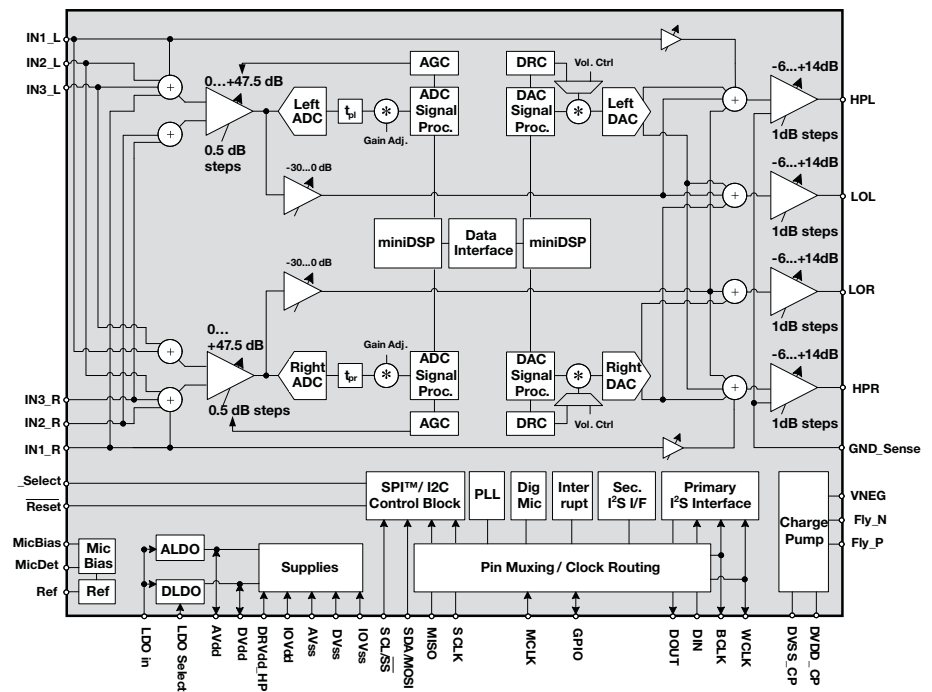

TLV320AIC3256 functional block diagram

Data Converters

→ Audio Converters – ADCs

Audio Analog-to-Digital Converters

Device	Description	ADC SNR (typ) (dB)	Inputs/Outputs	Max Sample-Rate (kHz)	Resolution (Bits)	Digital Audio Interface	Power Consumption (mW)	HiRel Avail.	Package	Price*
Battery-Powered										
TLV320ADC3001	92dB SNR Low-Power Stereo ADC	92	3/0	96	24	L, R, I ² S, DSP, TDM, PCM	17	N	DSBGA-16	1.45
TLV320ADC3101	92dB SNR Low-Power Stereo ADC with Digital Mic Support	92	6/0	96	24	L, R, I ² S, DSP, TDM, PCM	17	N	VQFN-24	1.55
PCM1870A	90dB SNR Low-Power Stereo Audio ADC with Microphone Bias, ALC, Sound Effect, Notch Filter	90	2/0	50	16	L, R, I ² S, DSP	13	N	DSBGA-24	1.70
Line-Powered										
PCM1802	105dB SNR Stereo ADC with Single-Ended Inputs	105	2/0	96	24	L, R, I ² S	225	N	DSBGA-16	3.35
PCM1803A	103dB SNR Stereo ADC with Single-Ended Inputs	103	2/0	96	24	L, R, I ² S	55	N	VQFN-24	1.10
PCM1804	112dB SNR Stereo ADC with Differential Inputs	112	2/0	192	24	L, R, I ² S, DSP	225	N	DSBGA-24	3.95
PCM1808	99dB SNR Stereo ADC with Single-Ended Inputs	99	2/0	96	24	L, I ² S	62	N	TSSOP-14	1.00
PCM1850A	101dB SNR Stereo ADC with 6x2 Ch MUX and PGA	101	6 x 2/2	96	24	L, R, I ² S	160	N	TQFP-32	5.15
PCM1851A	101dB SNR Stereo ADC with 6x2 Ch MUX and PGA	101	6 x 2/2	96	24	L, R, I ² S	160	N	TQFP-32	5.15
PCM4201	112dB SNR Low-Power Mono Audio ADC	112	1/0	108	24	PCM, DSP	40	N	TSSOP-16	2.50
PCM4202	118dB SNR Stereo Audio ADC	118	2/0	216	24	PCM, DSD	300	Y	SSOP-28	4.95
PCM4204	118dB SNR 4-Channel Audio ADC	118	4/0	216	24	PCM, DSD	600	N	HTQFP-64	7.95
PCM4220	123dB SNR Stereo Audio ADC with PCM Output	123	2/0	216	24	L, I ² S, TDM	305	N	TQFP-48	9.95
PCM4222	124dB SNR Stereo Audio ADC with PCM/DSD and Modulator Outputs	124	2/0	216	24	L, I ² S, TDM, DSD	305	N	TQFP-48	14.95

→ Audio Converters – DACs

Audio Digital-to-Analog Converters

Device	Description	DAC SNR (typ) (dB)	Inputs/Outputs	Max Sample-Rate (kHz)	Res. (Bits)	Digital Audio Interface	Power Consumption (mW)	IC Integration	HiRel Avail.	Package(s)	Price*
Battery-Powered											
PCM1773	98dB SNR Low-Power Stereo DAC with Line-Out (H/W Control)	98	0/2	48	24	L, I ² S	6.5	—	N	TSSOP-16, VQFN-20	1.35
PCM1774	93dB SNR Low-Power Stereo DAC with HP Amplifier (S/W Control)	93	0/2	50	16	L, R, I ² S, DSP	7	—	N	QFN-20	1.50
TLV320DAC3100	Low-Power Stereo Audio DAC with Mono Class-D Speaker Amplifier	95	2/4	192	32	L, R, I ² S, TDM, DSP	13	Class-D Speaker Amp	N	QFN-32	1.45
TLV320DAC3101	Low-Power Stereo Audio DAC with Stereo Class-D Speaker Amplifier	95	2/4	192	32	L, R, I ² S, TDM, DSP	13	Class-D Speaker Amp	N	QFN-32	1.75
TLV320DAC3120	Low-Power Audio DAC with miniDSP and 2.5W Mono Class-D Speaker Amplifier	95	2/2	192	32	L, R, I ² S, TDM, DSP	10	Class-D Speaker Amp, miniDSP	N	QFN-32	1.75
TLV320DAC32	Low-Power Stereo DAC with 4 Outputs, HP/Speaker Amplifier and 3-D Effects	95	2/4	96	24	L, R, I ² S, DSP, TDM	18	Class-AB Speaker Amp	N	QFN-32	1.35
TLV320AIC3253	Ultra-Low Power Stereo Audio Codec with Embedded miniDSP	100	4/2	192	32	L, R, I ² S, TDM, DSP	4.5	miniDSP	N	VQFN-24, DSBGA-25	2.95
TSC2102	"SMART" 4-Wire Touch-Screen Controller with Stereo DAC with HP Amplifier	96	0/2	53	24	I ² S, R, L, DSP	11	Touch-Screen Controller, Class-AB Speaker Amp	N	TSSOP-32	3.75
Line-Powered											
DSD1792A	132dB SNR Highest Performance Stereo Audio DAC (S/W Control)	127	0/2	192	24	L, R, I ² S, TDMCA, DSD	205	—	N	SSOP-28	10.65
DSD1796	123dB SNR Stereo DAC (S/W Control)	123	0/2	192	24	L, R, I ² S, TDMCA, DSD	115	—	N	SSOP-28	2.95
PCM1602A	105dB SNR 6-Channel Audio DAC	105	0/6	192	24	L, R, I ² S	171	—	N	LQFP-48	2.80

*Suggested resale price in U.S. dollars in quantities of 1,000. See www.ti.com/hirel for HiRel options.

Data Converters

→ Audio Converters – DACs

Audio Digital-to-Analog Converters (continued)

Device	Description	DAC SNR (typ) (dB)	Inputs/Outputs	Max Sample-Rate (kHz)	Res. (Bits)	Digital Audio Interface	Power Consumption (mW)	IC Integration	HiRel Avail.	Package(s)	Price*
Line-Powered (continued)											
PCM1606	103dB SNR 6-Channel Audio DAC	103	0/6	192	24	L, R, I ² S, TDM	250	—	N	SSOP-20	2.00
PCM1609A	105dB SNR 8-Channel Audio DAC	105	0/8	192	24	L, R, I ² S	224	—	N	LQFP-48	3.20
PCM1681	105dB SNR 8-Channel Audio DAC with TDM Mode	105	0/8	200	24	L, R, I ² S, TDM, DSP	386	—	Y	HTSSOP-28	1.65
PCM1690	113dB SNR 8-Channel Audio DAC with Differential Outputs	113	0/8	192	24	L, R, I ² S, TDM, DSP	558	—	N	HTSSOP-48	2.60
PCM1691	111dB SNR 8-Channel Audio DAC with Single-Ended Output	111	0/8	192	24	L, R, I ² S, TDM, DSP	558	—	N	HTSSOP-48	2.50
PCM1780	106dB SNR Stereo DAC (S/W Control)	106	0/2	192	24	L, R, I ² S	80	—	N	SSOP-16, QSOP	1.00
PCM1781	106dB SNR Stereo DAC (H/W Control)	106	0/2	192	24	R, I ² S	80	—	N	SSOP-16, QSOP	1.10
PCM1782	106dB SNR Stereo DAC (S/W Control)	106	0/2	192	24	L, R, I ² S	80	—	N	SSOP-16, QSOP	1.00
PCM1789	113dB SNR Stereo DAC	113	0/2	192	24	L, R, I ² S, DSP	154	—	N	TSSOP-24	1.90
PCM1792A	132dB SNR Highest Performance Stereo DAC (S/W Control)	127	0/2	192	24	L, R, I ² S, TDMCA, DSD	205	—	N	SSOP-28	10.65
PCM1794A	132dB SNR Highest Performance Stereo DAC (H/W Control)	127	0/2	192	24	L, R, I ² S	205	—	N	SSOP-28	10.65
PCM1795	32-Bit, 192kHz Sampling, Advanced Segment, Audio Stereo DAC	123	0/2	200	32	L, R, I ² S, TDMCA, DSD	110	—	N	SSOP-28	3.95
PCM1796	123dB SNR Stereo DAC (S/W Control)	123	0/2	192	24	L, R, I ² S, TDMCA, DSD	115	—	N	SSOP-28	2.95
PCM1798	123dB SNR Stereo DAC (H/W Control)	123	0/2	192	24	L, R, I ² S	115	—	N	SSOP-28	2.95
PCM4104	118dB SNR 4-Channel Audio DAC	118	0/2x2	192	24	I ² S, TDM	200	—	Y	TQFP-48	4.95

→ Audio Converters – Codecs

Audio Codecs

Device	Description	ADC SNR (typ) (dB)	DAC SNR (typ) (dB)	Inputs/Outputs	Max Sample-Rate (kHz)	Res. (Bits)	Digital Audio Interface	Power Consumption (mW)	IC Integration	HiRel Avail.	Package(s)	Price*
Battery-Powered												
TLV320AIC1106	PCM Codec With Microphone Amps and Speaker Driver	62	68	1/1	8	13	PCM	13.5	—	N	TSSOP-20	2.70
TLV320AIC12K	Low-Power Mono Voice Band Codec with 8-Ohm Speaker Amplifier	84	92	3/3	26	16	DSP, SMART TDM	11.2	Class-AB Speaker Amp	N	TSSOP-30, QFN-32	1.60
TLV320AIC24K	Low-Power Stereo Voice Band Codec	84	92	5/3	26	16	DSP, SMART TDM	20	—	N	TQFP-48	2.45
TLV320AIC3007	Low-Power Stereo Codec with Integrated Class-D Amplifier	87	93	7/6	96	24	L, R, I ² S, TDM, DSP	15	Class-D Speaker Amp	N	WQFN-40	2.35
TLV320AIC3100	Low-Power Audio Codec with 2.5W Mono Class-D Speaker Amplifier	91	95	3/3	192	32	L, R, I ² S, TDM, DSP	13	Class-D Speaker Amp	N	QFN-32	1.95
TLV320AIC3101	Low-Power Stereo Codec with 6 Inputs, 6 Outputs, Speaker/HP Amp and Enhanced Digital Effects	92	102	6/6	96	24	L, R, I ² S, DSP, TDM	14	Class-AB Speaker Amp	N	QFN-32	2.10
TLV320AIC3104	Low-Power Stereo Codec with 6 Inputs, 6 Outputs, HP Amp and Enhanced Digital Effects	92	102	6/6	96	24	L, R, I ² S, DSP, TDM	14	—	Y	QFN-32	1.95
TLV320AIC3105	Low-Power Stereo Codec with 6 Inputs, 6 Outputs, HP Amp and Enhanced Digital Effects	92	102	6/6	96	24	L, R, I ² S, DSP, TDM	14	—	N	QFN-32	1.95

*Suggested resale price in U.S. dollars in quantities of 1,000. See www.ti.com/hirel for HiRel options.

→ Audio Converters – Codecs

Audio Codecs (continued)

Device	Description	ADC SNR (typ) (dB)	DAC SNR (typ) (dB)	Inputs/Outputs	Max Sample-Rate (kHz)	Res (Bits)	Digital Audio Interface	Power Consumption (mW)	IC Integration	HiRel Avail.	Package(s)	Price*
Battery-Powered (continued)												
TLV320AIC3106	Low-Power Stereo Codec with 10 Inputs, 7 Outputs, HP Amplifier and Enhanced Digital Effects	92	102	10/7	96	24	L, R, I ² S, DSP, TDM	14	—	Y	VQFN-48, BGA-80 MicroStar Junior™	2.25
TLV320AIC3107	Low-Power Stereo Codec with Integrated Mono Class-D Amplifier	92	97	7/6	96	24	L, R, I ² S, DSP, TDM	14	Class-D Speaker Amp	N	WQFN-40, DSBGA-42	2.55
TLV320AIC3110	Low-Power Audio Codec with 1.3W Stereo Class-D Speaker Amplifier	90	95	3/4	192	32	L, R, I ² S, TDM, DSP	13	Class-D Speaker Amp	N	QFN-32	2.25
TLV320AIC3111	Low-Power Audio Codec with Embedded miniDSP and Stereo Class-D Speaker Amplifier	90	95	3/4	192	32	L, R, I ² S, TDM, DSP	13	Class-D Speaker Amp miniDSP	N	QFN-32	2.95
TLV320AIC3120	Low-Power Audio Codec with miniDSP and 2.5W Mono Class-D Speaker Amp	90	95	3/2	192	32	L, R, I ² S, TDM, DSP	10	Class-D Speaker Amp	N	QFN-32	2.25
TLV320AIC3204	Very Low-Power Stereo Audio Codec with PowerTune™ Technology	93	100	6/4	192	32	L, R, I ² S, TDM, DSP	4.1	—	N	QFN-32	2.25
TLV320AIC3253	Ultra-Low Power Stereo Audio Codec with Embedded miniDSP	—	100	4/2	192	32	L, R, I ² S, TDM, DSP	4.5	miniDSP	N	VQFN-24, DSBGA-25	2.95
TLV320AIC3254	Very Low-Power Stereo Audio Codec with miniDSP and PowerTune Technology	93	100	6/4	192	32	L, R, I ² S, TDM, DSP	4.1	miniDSP	N	QFN-32	3.95
TLV320AIC36	Low-Power Stereo Audio Codec for Portable Audio/Telephony	92	100	8/8	192	32	L, R, I ² S, TDM, DSP	10	miniDSP	N	BGA-80 MicroStar Junior	4.25
TSC2100	"SMART" 4-Wire Touch-Screen Controller with Stereo DAC/Mono ADC with HP/ Speaker Amplifier	88	96	2/2	53	24	I ² S, R, L, DSP	11	Touch-Screen Controller, Class-AB Speaker Amp	N	QFN-32, TSSOP-32	3.70
TSC2101	"SMART" 4-Wire Touch-Screen Controller, St. DAC/Mono ADC with HP/Speaker Amplifier	88	95	6/5	53	24	I ² S, R, L, DSP	11	Touch-Screen Controller, Class-AB Speaker Amp	N	VQFN-48	4.50
TSC2111	"SMART" 4-Wire Touch-Screen Controller, St. DAC/Mono ADC, 6 Audio Inputs and HP/ Speaker Amplifier	88	95	6/5	53	24	I ² S, R, L, DSP	19	Touch-Screen Controller, Class-AB Speaker Amp	N	VQFN-48	4.35
TSC2117	4-Wire Touch-Screen Controller with Low-Power Mono ADC/Stereo DAC	90	95	3/4	192	24	I ² S, R, L, TDM, DSP	13	Touch-Screen Controller, Class-D Speaker Amp, miniDSP	N	VQFN-48	5.15
Line-Powered												
PCM3052A	24-Bit Stereo Audio Codec with Mic Amp, Bias, MUX and PGA	101	105	2/2	96	24	I ² S	228	—	N	VQFN-32	3.00
PCM3060	24-Bit Asynchronous Stereo Audio Codec with 96/192kHz Sampling Rate	99	105	2/2	192	24	R, L, I ² S	160	—	N	TSSOP-28	2.10
PCM3168A	24-Bit Multichannel Audio Codec 6 Ch-In/8 Ch-Out with 96/192kHz Sampling Rate	107	112	6/8	192	24	R, L, I ² S, TDM, DSP	1160	—	Y	HTQFP-64	4.60
PCM5310	4 Ch/4 Ch Audio Codec with 2Vrms Driver	95	100	12/6	192	24	I ² S, L, R, RJ	360	—	N	HTQFP-64	3.40

*Suggested resale price in U.S. dollars in quantities of 1,000. See www.ti.com/hirel for HiRel options.

Data Converters

→ Audio Interface and Sample-Rate Converters

Interface and Sample-Rate Converters

Device	Description	No. of SRC Channels	THD+N (dB)	Sample-Rate (max)	Inputs	Digital Audio Interface	Control Interface	Dynamic Range (dB)	AES Receive/Transmit	HiRel Avail.	Power Supply (V)	Package	Price*
S/PDIF/AES3 Transmitter													
DIT4192	192kHz Digital Audio Transmitter	—	—	192	—	AES/EBU, S/PDIF, I ² S, R, L	H/W, SPI™	—	—/Yes	N	3.3, 5.0	TSSOP-28	2.05
DIT4096	96kHz Digital Audio Transmitter	—	—	96	—	AES/EBU, S/PDIF, I ² S, R, L	H/W, SPI	—	—/Yes	N	3.3, 5.0	TSSOP-28	1.55
S/PDIF/AES3 Receiver													
DIR9001	96kHz Digital Audio Receiver	—	—	96	—	AES/EBU, S/PDIF, I ² S, R, L	H/W	—	Yes/No	Y	3.3	TSSOP-28	1.95
S/PDIF/AES3 Transceiver													
DIX4192	Digital Audio Interface Transceiver	—	—	216	4 Differential Inputs	AES/EBU, S/PDIF, I ² S, R, L	I ² S, SPI	—	Yes/Yes	N	2.9, 3.7	TQFP-48	3.95
DIX9211	Digital Audio Interface Transceiver	—	—	216	Up to 12 Single Ended Inputs	AES/EBU, S/PDIF, I ² S, R, L	I ² S, SPI	—	Yes/Yes	N	2.9, 3.6	LQFP-48	2.95
Sample-Rate Converter													
SRC4184	4-Channel, Asynchronous Sample-Rate Converter	4	-125	212	—	I ² S, R, L, TDM	SPI	128	—	N	1.8, 3.3	TQFP-64	7.50
SRC4190	192kHz Stereo, Asynchronous Sample-Rate Converter	2	-125	212	—	I ² S, R, L, TDM	H/W	128	—	Y	3.3	SSOP-28	4.50
SRC4192	High-End Sample-Rate Converter	2	-140	212	—	I ² S, R, L, TDM	H/W	144	—	N	3.3	SSOP-28	7.50
SRC4193	High-End Sample-Rate Converter	2	-140	212	—	I ² S, R, L, TDM	SPI	144	—	N	3.3	SSOP-28	8.50
SRC4194	4-Channel, Asynchronous Sample-Rate Converter	4	-140	212	—	I ² S, R, L, TDM	SPI	144	—	N	1.8, 3.3	TQFP-64	12.50
Sample-Rate Converter with Integrated Transceiver													
SRC4382	Combo Sample-Rate Converter	2	-125	216	—	AES/EBU, S/PDIF, I ² S, R, L	I ² S, SPI	128	Yes/Yes	N	1.8, 3.3	TQFP-48	7.50
SRC4392	High-End Combo Sample-Rate Converter	2	-140	216	—	AES/EBU, S/PDIF, I ² S, R, L	I ² S, SPI	144	Yes/Yes	N	1.8, 3.3	TQFP-48	9.95

→ Audio Line Drivers

Audio Line Drivers and Receivers

Device	Description	Fixed/Variable Gain	Supply Min (V+ + V-)	Supply Max (V+ + V-)	GBW (typ) (MHz)	Slew Rate (typ) (V/μs)	Distortion at 1kHz (typ) (%)	HiRel Avail.	Package(s)	Price*
Audio Line Drivers										
DRV134/DRV135	Audio-Balanced Line Driver	Fixed-2V	9	36	1.5	15	0.00050	N	SOIC-16, PDIP-8, SOIC-8	1.95
DRV602/DRV603	3-V _{RMS} DirectPath™ Pop-Free Variable Input Gain Line Driver with Diff Inputs	Variable	3	5.5	8	4.5	0.01000/ 0.00100	N	TSSOP-14	0.70/0.85
DRV604	2V _{RMS} Line Driver and Headphone Amp with Adjustable Gain	Variable	3	3.7	8	4.5	0.00100	N	HTSSOP-28	1.00
Audio Line Receivers										
INA134	Audio Differential Line Receiver	Fixed-0dB (G=1)	8	36	3.1	14	0.00050	N	PDIP-8, SOIC-8	1.05
INA137	Audio Differential Line Receiver	Fixed - ± 6dB (G=1/2 or 2)	8	36	4	14	0.00050	N	PDIP-8, SOIC-8	1.05
INA2134	Audio Differential Line Receiver	Fixed-0dB (G=1)	8	36	3.1	14	0.00050	N	PDIP-14, SOIC-14	1.70
INA2137	Audio Differential Line Receiver	Fixed - ± 6dB (G=1/2 or 2)	8	36	4	14	0.00050%	N	PDIP-14, SOIC-14	1.70

→ Digitally Controlled Microphone Preamplifiers

PGAs

Device	Description	Gain Range (dB)	Noise (Ein) with G=30dB	THD+N with Gain = 30dB (percent)	Power Supply	HiRel Avail.	Package	Price*
Microphone Preamplifiers								
PGA2500	Digitally Controlled Microphone Preamplifier	0dB, and 10dB to 65dB in 1dB Steps	-128dBu	0.004000%	±5	N	SSOP-28	7.95
PGA2505	Digitally Controlled Microphone Preamplifier	0dB and 9dB to 60dB in 3dB Steps	-123dBu	0.000600%	±5	N	SSOP-28	8.75

*Suggested resale price in U.S. dollars in quantities of 1,000. See www.ti.com/hirel for HiRel options.

➔ Analog Front Ends – Medical

Integrated 8-Channel Analog Front Ends for Spectral Doppler Ultrasound

AFE5807, AFE5808

Get samples, datasheets and evaluation modules at: www.ti.com/sc/device/AFE5807 or www.ti.com/sc/device/AFE5808

Key features

- Integrated CW doppler mixer and summing amplifier
- AFE5807: low-power solution
 - 88mW/ch at 1.1nV/√Hz, 40MSPS, 12-bit sampling
- AFE5808: high-performance solution
 - 0.75nV/√Hz, 149mW/ch, 65MSPS, 14-bit sampling with 77dBFS SNR
- Both integrate eight channels of the following components:
 - LNA with 24/18/12dB gain settings
 - VCA/PGA w/ total max gain of 54dB
 - 3rd order LPF w/selectable band width of 10, 15, 20, and 30MHz
 - 12- and 14-bit ADC with LVDS output up to 65MSPS
 - Programmable modes to optimize power and performance for various imaging modes

The AFE5807 and AFE5808 are two new fully integrated analog front ends (AFEs) with continuous wave (CW) mode for mid- to high-end, Spectral Doppler ultrasound equipment. The AFE5808 has best-in-class noise performance at 0.75nV/√Hz, 149mW/ch, 65MSPS and a 14-bit ADC with 77dBFS SNR. The AFE5807 is a low-power solution with 88mW/ch at 1.1nV/√Hz, 40MSPS, and 12-bit sampling.

The AFE5807/08 contains eight channels of a low noise amplifier (LNA), Voltage Controlled Attenuator (VCA), Programmable Gain Amplifier (PGA), Low Pass Filter (LPF) and 12-/14-bit analog-to-digital converter with LVDS data outputs and a conversion rate of up to 65MSPS. Its passive CW mixer enables users to simplify the CW beam-former design and achieve satisfactory CW performance at low power consumption.

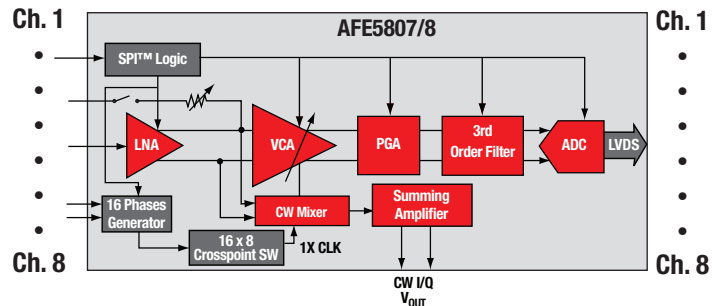

AFE5807/8 diagram

Applications

- Ultrasound

Integrated 8- and 16-Channel Analog Front Ends for Handheld Ultrasound

AFE5801, AFE5851

Get samples, datasheets and evaluation modules at: www.ti.com/sc/device/AFE5801 or www.ti.com/sc/device/AFE5851

Key features

- Integrated VCA, PGA, LPF, 12-bit 65MSPS ADC
- AFE5801:
 - 8 channels
 - 50mW per channel at 30MSPS
 - 58mW per channel at 50MSPS
- AFE5851:
 - 16 channels
 - 39mW per channel at 32.5MSPS
- Digital gain control removes external DAC for smaller footprint and minimized noise
- Packaging: 9 x 9mm QFN

The AFE5851 is the first 16-channel AFE available for the ultrasound market. The device features 39mW/channel at 32.5MSPS and contains 16 variable-gain amplifiers (VGAs), followed by eight 12-bit, 65MSPS analog-to-digital converters (ADCs). Each ADC is shared between two VGAs and each VGA differential output is sampled at alternate clock cycles to optimize power dissipation. The ADC has scalable power consumption to enhance the lower power with lower sampling rates. The high channel count and low-power features of the AFE5851 allow for increased channel density in handheld ultrasound systems.

Both the AFE5851 and AFE5801 can be preceded by an off-chip low-noise amplifier (LNA), which can be on the probe or be a transformer. This new architecture enables customers to

have more than 40 percent less power and a 70 percent smaller analog front-end footprint for handheld ultrasound systems.

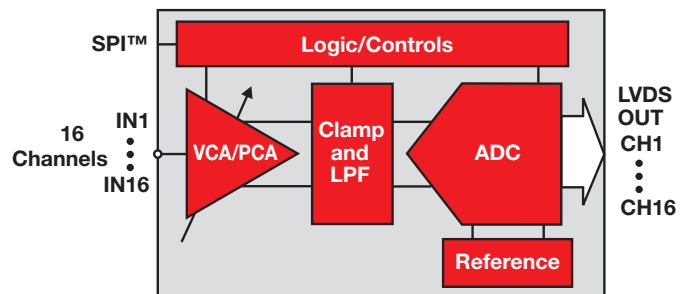

AFE5851 functional diagram

➔ Analog Front Ends – Medical

Low-Power, 8-Channel, 24-Bit Analog Front End for Biopotential Measurements

ADS1298

Get samples and datasheets at: www.ti.com/sc/device/ADS1298

Key Features

- Eight low-noise PGAs and eight high-resolution ADCs (ADS1298)
- Low power: 0.75mW/channel
- Input-referred noise: 4μVPP (150Hz BW, G = 6)
- Input bias current: 200pA
- Data rate: 250SPS to 32kSPS
- CMRR: –115dB
- Programmable gain: 1, 2, 3, 4, 6, 8 or 12
- Built-in right leg drive amplifier, lead-off detection, WCT, test signals

Applications

- Medical instrumentation (ECG and EEG), including:
 - Patient monitoring; holter, event, stress, and vital signs ECG, AED, telemedicine, fetal ECG
 - Bispectral index (BIS), evoked audio potential (EAP), sleep study monitor
- High-precision, simultaneous, multichannel signal acquisition

The ADS1294/6/8 are a family of multichannel, simultaneous sampling, 24-bit, delta-sigma ($\Delta\Sigma$) analog-to-digital converters (ADCs) with a built-in programmable gain amplifier (PGA), internal reference and onboard oscillator. The ADS1294/6/8 incorporate all of the features that are commonly required in medical electrocardiogram (ECG) and electroencephalogram (EEG) applications.

With its high levels of integration and exceptional performance, the ADS1294/6/8 family enables the creation of scalable medical instrumentation systems at significantly reduced size, power and overall cost.

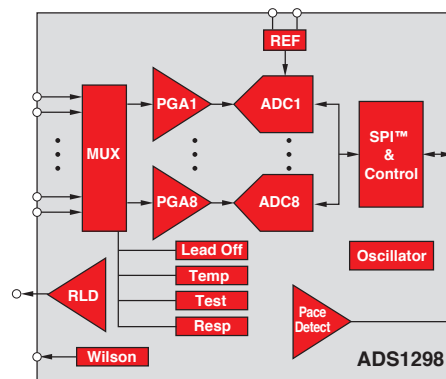

ADS1298 functional block diagram

Analog Front Ends for Ultrasound

Product	Channels	Integration	Power	Noise	ADC SNR	Package(s)	Price*
AFE5808	8	LNA+VCA+LPF+ADC+ CW	136mW/Ch at 40 MSPS	0.75nV/√Hz	77dBFS	135-pin, 15x9mm	68.00
AFE5807	8	LNA+VCA+LPF+ADC+ CW	88mW/Ch at 40 MSPS	1.1nV/√Hz	74dBFS	135-pin, 15x9mm	62.00
AFE5805	8	LNA+VCA+LPF+ADC	122mW/Ch at 40 MSPS	0.85nV/√Hz	70dBFS	135-pin, 15x9mm	56.00
AFE5804	8	LNA+VCA+LPF+ADC	101mW/Ch at 40 MSPS	1.23nV/√Hz	69dBFS	135-pin, 15x9mm	58.00
AFE5801	8	VCA+LPF+ADC	58mW/Ch at 50 MSPS	5.0nV/√Hz (without LNA)	66dBFS	64-pin, 9x9mm	52.00
AFE5851	16	VCA+LPF+ADC	39mW/Ch at 32.5 MSPS	5.0nV/√Hz (without LNA)	66dBFS	64-pin, 9x9mm	92.00

Biopotential Sensing (ECG/EEG) Delta-Sigma ADCs

Device	Res. (Bits)	Sample-Rate (kSPS)	Number of Input Channels	Interface	Input-Referred Noise (μVpp)	Common Mode Rejection (dB)	Power (mW)	HiRel Avail.	Package(s)	Price*
ADS1298	24	32	8 Diff	SPI™	4	115	6	N	BGA-64, TQFP-64	23.95
ADS1296	24	32	6 Diff	SPI	4	115	5.1	N	BGA-64, TQFP-64	17.95
ADS1294	24	32	4 Diff	SPI	4	115	3.6	N	BGA-64, TQFP-64	11.95
ADS1198	16	8	8 Diff	SPI	12	100	4.5	N	BGA-64, TQFP-64	8.00
ADS1196	16	8	6 Diff	SPI	12	100	3.9	N	BGA-64, TQFP-64	11.95
ADS1194	16	8	4 Diff	SPI	12	100	3	N	BGA-64, TQFP-64	15.95

*Suggested resale price in U.S. dollars in quantities of 1,000.

New products are listed in bold red.

Data Converters

→ Analog Front Ends – Imaging

TI Covers the Image Capture Spectrum

TI's product line covers a broad spectrum of image capture applications with diverse requirements. Portfolio offerings, application support, product quality and manufacturing excellence allow you to customize imaging systems for specific applications with confidence. TI's imaging products are optimized to work together, yet also allow you to mix-and-match with third-party components when required. Use the guides and information featured in this brochure to make the best selections for your needs.

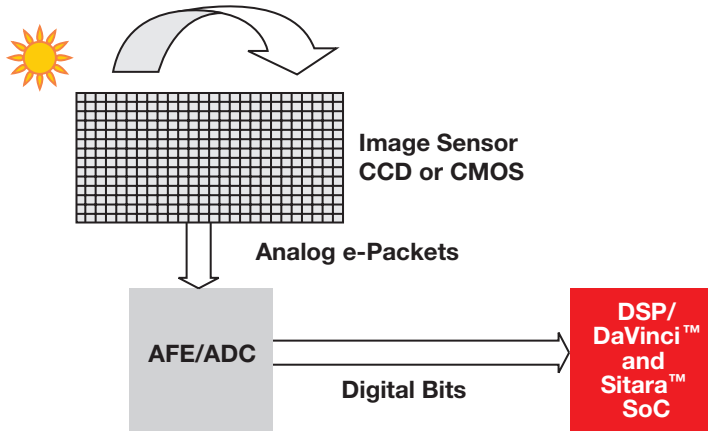
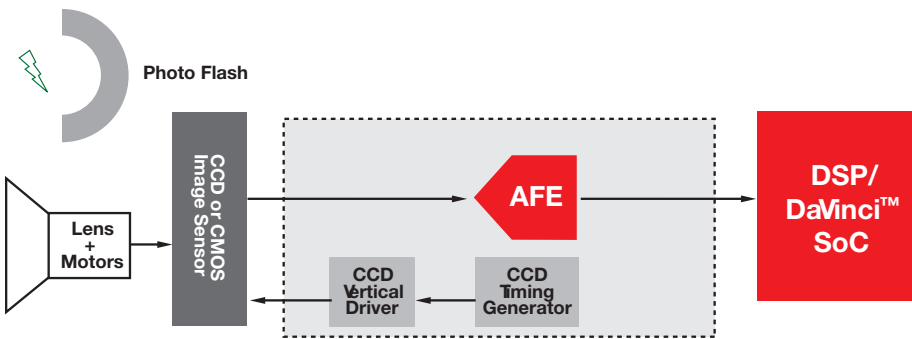

Image sensor and imaging AFE/ADC

Image Sensor:

- Converts photons to electrons stored in the pixel
- CCD output requires correlated double sampling (CDS)
 - CMOS output requires sample and hold (S/H)



Typical imaging block diagram

Imaging AFE/ADC:

- Conditions and digitizes sensor output
- Samples and conditions the sensor output (CDS or S/H)
 - Digitizes the signal for DSP
 - Optional AFE sensor support functions
 - Provides CMOS-level timing signals for sensor operation
 - Provides voltage level-shifting

Imaging Analog Front End Devices

Device	Description	AFE	TG	VD	SNR (dB)	Bits Out	MSPS (MHz)	Pd (mW)	V _S (V)	DNL (±LSB)	INL (±LSB)	Gain (dB)	HiRel Avail.	Package	Price*
Single-Channel AFE															
VSP2582	Single Ch., 12b, 36MSPS	Y	—	—	78	12	36	85	2.7 to 3.3	0.5	2	-9 to +35	N	QFN-36	3.20
Multi-Channel AFE															
VSP2590	2 Ch., 16b, 41MSPS SNR	Y	—	—	75	16	41.5	290	2.7 to 3.3	0.8	32	-3 to +50	N	BGA-159	18.00
AFE for Line Sensor															
VSP5010	2 Ch., 12b, 31MSPS	Y	—	—	78	12	30	290	3 to 3.6	0.5	2	0 to +24	N	LQFP-64	11.83
VSP7502	4 Ch., 16b, 54MSPS, LVDS Output	Y	3	—	78	16	54	400	1.8V core, 3.3V I/O	1	32	0 to +40	N	NFBGA-159	22.00

*Suggested resale price in U.S. dollars in quantities of 1,000.

→ Embedded Processors with Integrated ADCs

Embedded Processors with Integrated ADCs

Device	ADC Channels	ADC Resolution	ADC Sample-Rate	Max Speed	Flash	ROM	RAM	Standby Current	Active Current	MAX GPIO	Timers	HiRel Avail.	PWM	Price*
MSP430™														
MSP430G2131	8	10	200	16	1	0	0.125	0.5	0.22	10	2	N	2	0.49
MSP430F1122	5	10	200	8	4	0	0.25	0.7	0.2	14	2	N	3	1.65
MSP430F5505	8	10	200	25	16	0	6	2.6	0.16	31	5	N	18	1.75
MSP430F5510	12	10	200	25	32	0	6	2.6	0.16	47	5	N	18	1.90
MSP430F2272	12	10	200	16	32	0	1	0.5	0.27	32	3	N	6	2.20
MSP430F233	8	12	200	16	8	0	1	0.3	0.27	48	3	N	6	2.15
MSP430F2410	8	12	200	16	56	0	4	0.3	0.27	48	3	N	10	4.60
MSP430F5524	12	12	200	25	64	0	6	2.6	0.16	47	5	N	18	3.55
MSP430F5525	16	12	200	25	64	0	6	2.6	0.16	63	5	N	18	3.66
MSP430F2013	4	16	4	16	2	0	0.125	0.5	0.22	10	2	N	2	1.20
MSP430F478	5	16	32	8	48	0	2	1.1	0.28	48	3	N	6	5.00
MSP430F47176	6	16	32	16	92	0	8	1.1	0.35	68	3	N	6	5.90
MSP430F47187	7	16	32	16	116	0	8	1.1	0.35	68	3	N	6	7.55
C2000™														
TMS320F28021	13	12	2000	40	64	0	10	N/A	N/A	22	9	N	1	2.20
TMS320F28027	13	12	4600	60	64	0	12	N/A	N/A	22	9	N	1	2.85
TMS320F28022	13	12	3800	50	32	0	12	N/A	N/A	22	9	N	1	2.25
TMS320F280200	13	12	2000	40	16	0	6	N/A	N/A	22	8	N	0	1.85
TMS320F28235	16	12	12500	150	512	0	68	N/A	N/A	88	16	N	6	14.55
TMS320F2809	16	12	12500	100	256	0	36	N/A	N/A	35	14	N	4	12.95
TMS320F28035	16	12	4600	60	128	0	20	N/A	N/A	45	12	N	1	4.41
TMS320F28232	16	12	12500	100	128	0	52	N/A	N/A	88	14	N	4	12.88
TMS320F28031	16	12	2000	60	64	0	16	N/A	N/A	45	12	N	1	2.97
TMS320F2806	16	12	6250	100	64	0	20	N/A	N/A	35	14	N	4	8.70
TMS320F28015	16	12	3750	60	32	0	12	N/A	N/A	35	10	N	2	3.25
Stellaris®														
LM3S1165	4	10	500	50	64	0	16	0	0	43	6	N	6	3.15
LM3S5662	4	10	500	50	128	0	32	0	0	33	5	N	6	4.65
LM3S8933	4	10	1000	50	256	0	64	0	0	36	6	N	0	6.40
LM3S2276	6	10	1000	50	64	0	32	0	0	33	5	N	8	3.30
LM3S317	6	10	250	25	16	0	4	0	0	30	5	N	6	2.20
LM3S618	6	10	500	50	32	0	8	0	0	30	5	N	6	2.35
LM3S1608	8	10	500	50	128	0	32	0	0	52	6	N	0	3.35
LM3S3748	8	10	1000	50	128	0	64	0	0	61	6	N	8	5.05
LM3S8538	8	10	1000	50	96	0	64	0	0	36	6	N	0	6.20
LM3S1651	16	10	1000	80	128	0	32	0	0	67	7	N	6	4.45
LM3S5651	16	10	1000	80	128	0	32	0	0	67	7	N	6	5.25
LM3S9781	16	10	1000	80	128	0	64	0	0	65	7	N	0	7.20
ARM® Cortex® R4														
TMS570LS10106	24	12	1000	160	1024	0	128	N/A	N/A	114	32	N	32	20.46
TMS570LS10116	24	12	1000	160	1024	0	128	N/A	N/A	114	32	N	32	21.26
TMS570LS10206	24	12	1000	160	1024	0	160	N/A	N/A	114	32	N	32	20.66
TMS570LS10216	24	12	1000	160	1024	0	160	N/A	N/A	114	32	N	32	21.46
TMS570LS20206	24	12	1000	160	2048	0	160	N/A	N/A	114	32	N	32	23.16
TMS570LS20216	24	12	1000	160	2048	0	160	N/A	N/A	114	32	N	32	23.96

*Suggested resale price in U.S. dollars in quantities of 1,000.

→ Motor Drivers

Brushless DC Motor Pre-driver with Dual Shunt Amplifiers and a Buck Converter DRV8301

PREVIEW*

Get samples and datasheets at: www.ti.com/sc/device/DRV8301

Key Features

- Gate driver with 8-60V supply voltage and 1.7A gate current
- Dual shunt current amplifiers with output offset up to 3V
- Integrated buck converter with 3.5-60V input, adjustable output, up to 1A load
- Bootstrap structure with trickle charge
- Intelligent gate driver and cross conduction prevention
- OC protection of external FETs with programmable cycle-by-cycle current limit
- Independent control of six external MOSFETs
- SPI™ interface for programmability

Applications

- Three-phase permanent magnet synchronous motors
- CPAP
- E-bike
- Power tools

The DRV8301 is a gate driver IC for three-phase motor drive applications. It provides three half bridge drivers, each capable of driving two N-type MOSFETs, one for the high side and one for the low side. It supports up to 2.3A sink and 1.7A source peak current capability and only needs a single power supply with a wide range from 8 to 60V. The DRV8301 includes two current shunt amplifiers for accurate current measurement. The DRV8301 also has an integrated switching mode buck converter with adjustable output and switching frequency to support MCU or additional system power needs.

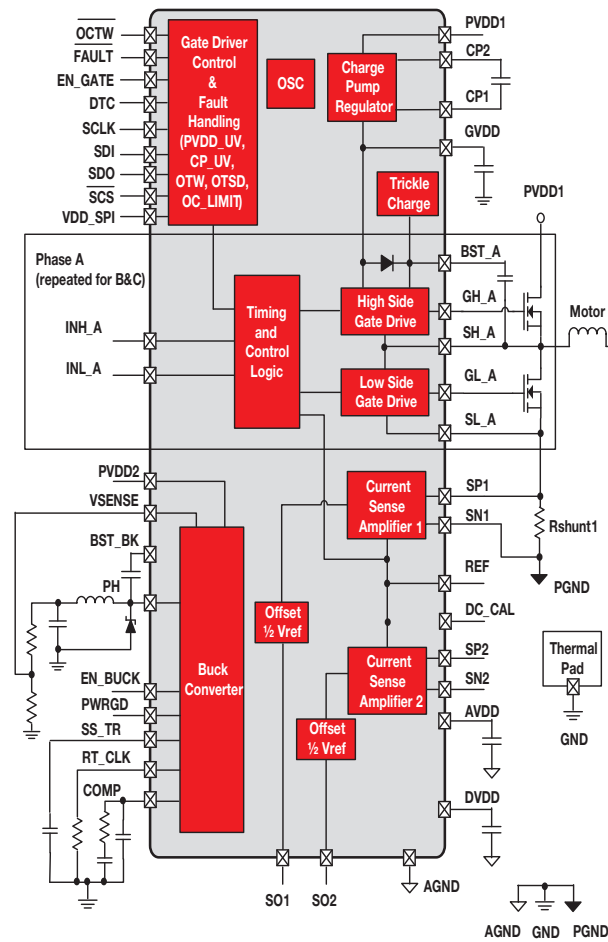

DRV8301 simplified application diagram

*Expected release date: Q2 2011

→ Motor Drivers

Dual Full-Bridge PWM Motor Driver DRV8412, DRV8432

Get samples and datasheets at: www.ti.com/sc/device/DRV8412 and www.ti.com/sc/device/DRV8432

Key Features

- High-efficiency power stage (up to 97%) with low RDS(on) MOSFETs (110mΩ at TJ = 25°C)
- Operating supply voltage up to 52V
- DRV8412 (power pad down): up to 2x3A continuous output current (2x6A peak) in dual full-bridge mode or 6A continuous current in parallel mode (12A peak)
- DRV8432 (power pad up): up to 2x7A continuous output current (2x12A peak) in dual full-bridge mode or 14A continuous current in parallel mode (24A peak)
- Integrated protection features
 - programmable cycle-by-cycle current limit
 - two-stage thermal protection

Applications

- Brushed DC and stepper motors
- Robotic and haptic control systems
- Actuators and pumps
- Precision instruments
- TEC drivers

The DRV8412/32 are high-performance, integrated dual full-bridge motor driver with an advanced protection system. Because of the low RDS(on) of the H-Bridge MOSFETs and intelligent gate drive design, the efficiency of these motor drivers can be up to 97%, which enables the use of smaller power supplies and heatsinks, and are good candidates for energy efficient applications.

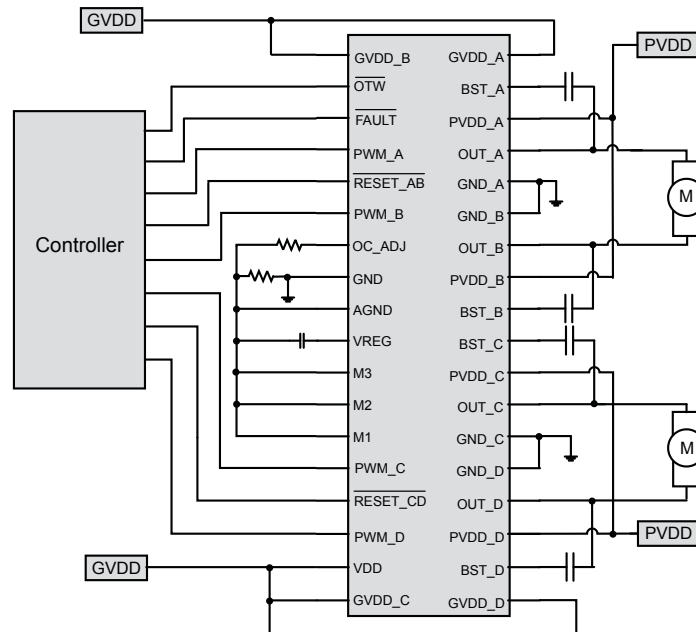

DRV8412 simplified application diagram

Monitoring and Control

→ Motor Drivers

Brushless DC Motor Controller IC DRV8710

Get samples and datasheets at: www.ti.com/sc/device/DRV8710

Key Features

- Three-phase brushless DC motor controller
 - Built-in speed control loop, including speed and phase comparators and loop filters
 - Clock input or direct PWM inputs for speed control
- Drives external N-channel FETs
- Differential hall sensor inputs
- FG amplifier
- Serial control interface
- EEPROM parameter storage
- Supports two commutation modes: standard 120° commutation and 120° single hall commutation

Applications

- Printers
- Scanners
- Office automation machines

The DRV8710 provides integrated control and power stage pre-drive for a three-phase brushless DC motor. Motor speed is controlled by a completely integrated digital speed control loop, using an external clock input to set motor speed. Adjustment of operating parameters is via EEPROM programming, which can be set at the factory or through a serial interface. Use of the serial interface is not required for normal device operation.

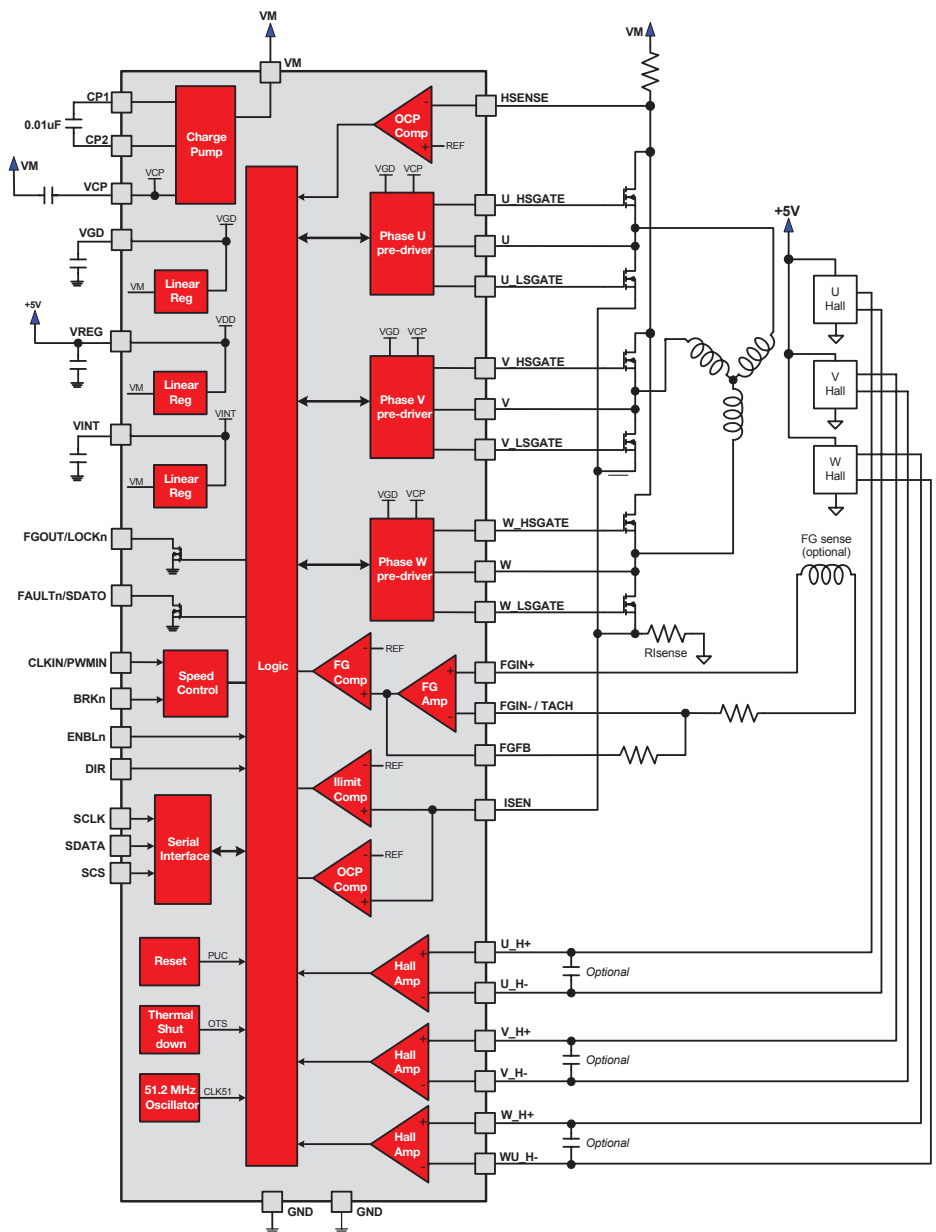

DRV8710 functional block diagram

→ Motor Drivers

Stepper Motor Controller IC DRV8825

Get samples and datasheets at: www.ti.com/sc/device/DRV8825

Key Features

- PWM microstepping motor driver
 - Built-in microstepping indexer
 - Five-bit winding current control allows up to 32 current levels
- 2.5A maximum drive current at 24V, 25°C
- 8V to 45V operating supply voltage range
- Advanced on-chip protection
 - Over-current
 - Thermal
 - Under-voltage

Applications

- Automatic teller machines
- Money handling machines
- Video security cameras
- Printers
- Scanners
- Office automation machines
- Gaming machines

The DRV8825 provides an integrated motor driver solution for printers, scanners and other automated equipment applications. The device has two H-bridge drivers and can drive a Bipolar stepper motor. Each of the output driver block consists of N-channel power MOSFET configured as full H-bridges to drive the motor windings. The DRV8825 can supply up to 2.5A peak or 1.75A RMS output current (with proper heatsinking at 24V and 25°C).

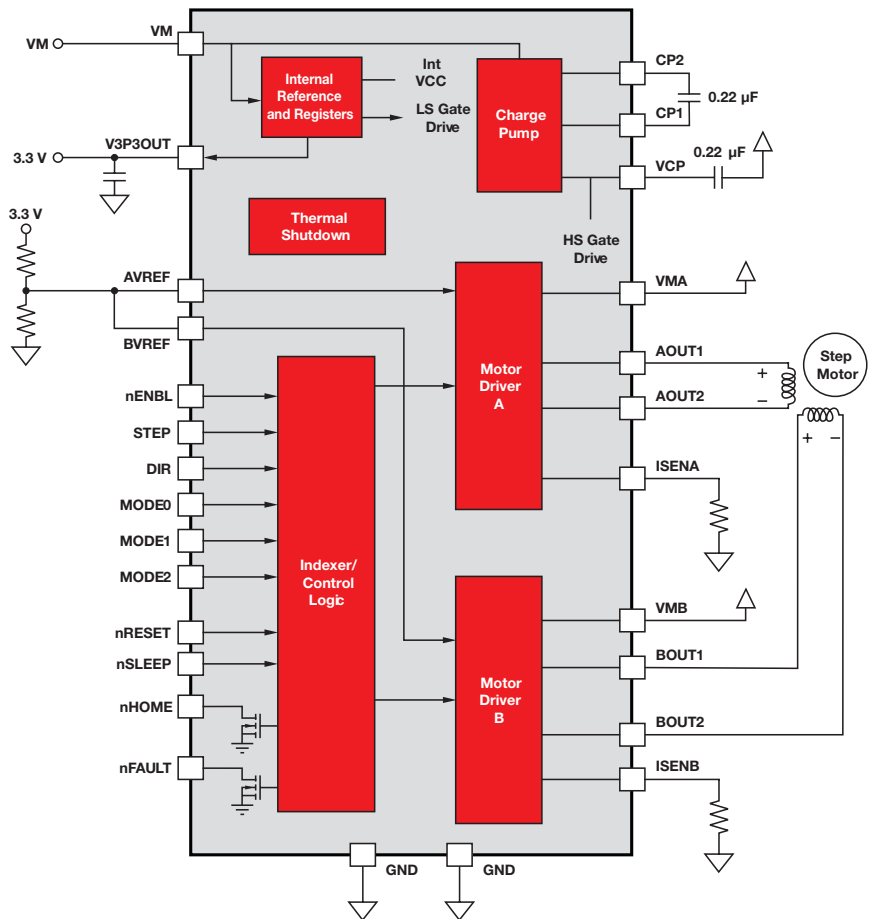

DRV8825 functional block diagram

Monitoring and Control

→ Motor Drivers

Motor Drivers

Device	Description	Status	Supply Voltage	I _{OUT} Cont.	I _{OUT} Peak	Motors Supported	Interface	HiRel Avail.	Price*
DRV8412	Dual Full Bridge for a Single Bipolar Stepper Motor or 2x Brushed DC (No Heat Sink Required)	Released	0V to +52V	3A	6A	Dual Brushed DC, Bipolar Stepper Motor, 4x Solenoids	PWM Input	N	3.85
DRV8432	Dual Full Bridge for a Single Bipolar Stepper Motor or 2x Brushed DC (Heat Sink Required)	Released	0V to +52V	7A	12A	Dual Brushed DC, Bipolar Stepper Motor, 4x Solenoids	PWM Input	N	5.50
DRV8312	3-Phase Motor Driver (No Heat Sink Required)	Released	0V to +52V	3.5A	6.5A	PMSM, BLDC	PWM Input	N	3.30
DRV8332	3-Phase Motor Driver (Heat Sink Required)	Released	0V to +52V	8A	13A	PMSM, BLDC	PWM Input	N	4.70
DRV8301	3-Phase Motor Driver Includes 2 Channels of Current Sense Feedback and a Buck Converter	Sampling	+8V to +60V	Ext. FETs	Ext. FETs	PMSM, BLDC	PWM Input	N	2.50
DRV8800	Single DC Motor Driver w/Brake	Released	+8V to +36V	2.8A	—	Brushed DC	PH/EN	N	1.25
DRV8801	DRV8800 with Current Sense Output	Released	+8V to +36V	2.8A	—	Brushed DC	PH/EN	N	1.25
DRV8811	1/8-Step with Adjustable Mixed-Decay	Released	+8V to +38V	1.75A	2.5A	Bipolar Stepper Motor	Indexer	N	1.80
DRV8812	Dual H-Bridge with On-Chip, 4-Level PWM Current Regulation	Released	+8V to +45V	1.1A	1.6A	Bipolar Stepper Motor	PH/EN	N	1.65
DRV8813	Dual H-Bridge with On-Chip, 4-Level PWM Current Regulation	Sampling	+8V to +45V	1.75A	2.5A	Bipolar Stepper Motor	PH/EN	N	2.30
DRV8814	DRV8813 with Brake Function	Sampling	+8V to +45V	1.75A	2.5A	Dual Brushed DC	PH/EN	N	2.30
DRV8821	Dual 1/8-Step Stepper w/Auto Decay Mode Selection	Released	+8V to +32V	1.5A	1.5A	Dual Bipolar Stepper Motor	Indexer	N	2.00
DRV8823	Quad H-Bridge w/Direct SPI™ Control	Released	+8V to +32V	1.5A	1.5A	Dual Bipolar Stepper Motor, Quad DC Motor	Serial SPI	N	2.00
DRV8824	1/32-Step Indexer	Released	+8V to +45V	1.1A	1.6A	Bipolar Stepper Motor	Indexer	N	1.65
DRV8825	1/32-Step Indexer	Sampling	+8V to +45V	1.75A	2.5A	Bipolar Stepper Motor	Indexer	N	2.30
DRV8828	On-Chip, 32-Level PWM Current Regulation	Released	+8V to +45V	2.1A	3A	Half-Winding Bipolar, Stepper Motor	PH/EN	N	1.65
DRV8829	On-Chip, 32-Level PWM Current Regulation	Sampling	+8V to +45V	3.5A	5A	Half-Winding Bipolar, Stepper Motor	PH/EN	N	2.30
DRV8840	DRV8829 with Brake Function	Sampling	+8V to +45V	3.5A	5A	Brushed DC	PH/EN	N	2.30
DRV8841	Dual H-Bridge with 4-Level PWM Current Regulation	Sampling	+8V to +45V	1.75A	2.5A	Dual Brushed DC, Bipolar Stepper Motor, 4x Solenoids	IN/IN	N	2.30
DRV8842	Single H-Bridge with 32-Level PWM Current Regulation	Sampling	+8V to +45V	3.5A	5A	Brushed DC, Half-Winding Bipolar Stepper Motor, 2x Solenoids	IN/IN	N	2.30
DRV8830	Low-Voltage Single Brushed DC	Released	+2.7V to +6.0V	1A	1A	Brushed DC	Serial (I ² C)	N	0.85
DRV8832	Low-Voltage Single Brushed DC	Released	+2.7V to +6.0V	1A	1A	Brushed DC 2x Solenoids	IN/IN	N	0.85
DRV8833	Dual H-Bridge for Low-Voltage Application	Sampling	+2.7V to +10.8V	800mA	2A	Dual Brushed DC, Bipolar Stepper Motor, 4x Solenoids	IN/IN	N	—
DRV8809	Motor Driver with 3 Integrated DC/DC Converters	Released	+8V to +40V	800mA	3A	Dual Bipolar Stepper Motor, Quad DC Motor	Serial (SPI)	N	5.40
DRV8810	DRV8809 w/Different Power-Up Timing	Released	+18V to +40V	800mA	3A	Dual Bipolar Stepper Motor, Quad DC Motor	Serial (SPI)	N	5.40

*Suggested resale price in U.S. dollars in quantities of 1,000.

Monitoring and Control

→ Touch-Screen Controllers

1.2V to 3.6V, 12-Bit, Nanopower, 4-Wire Touch-Screen Controller with I²C Interface

TSC2014

Get samples and datasheets at: www.ti.com/sc/device/TSC2014

Key Features

- 4-wire touch-screen interface
- Ratiometric conversion
- Single 1.2V to 3.6V supply
- Preprocessing to reduce bus activity
- High-speed I²C-compatible interface
- Automatic touch detection
- Register-based programmable:
 - 10-bit or 12-bit resolution
 - Sampling rates
 - System timing
- On-chip temperature measurement
- Auto power-down control

Applications

- Cell phones
- Portable instruments
- MP3 players, pagers
- Multiscreen touch control

The TSC2014 is a very low-power touch-screen controller designed to work with power-sensitive, handheld applications that are based on advanced low-voltage processors. It works with a supply voltage as low as 1.2V, which can be supplied by a single-cell battery. It contains a complete, ultralow-power, 12-bit, analog-to-digital (A/D) resistive touch-screen converter, including drivers and the control logic to measure touch pressure.

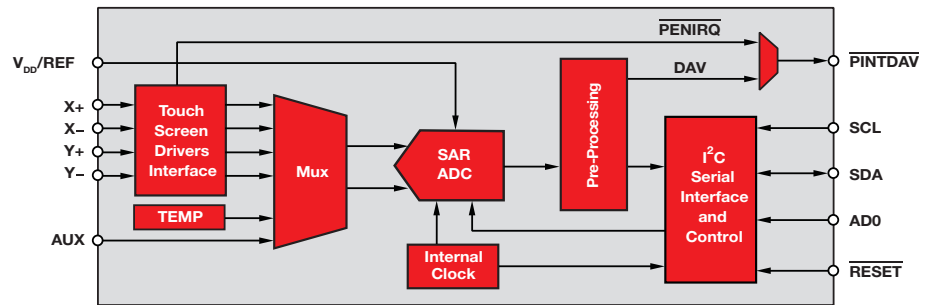

TSC2014 functional block diagram

Non-Audio Touch-Screen Controllers

Device	Touch Panel	Res. (Bits)	Interface	Features	ESD	V _{REF}	Supply Voltage (V)	Power Consumption (mW)	HiRel Avail.	Package(s)	Price*
ADS7843	4-Wire	12(8)	Serial, SPI™	X, Y, AUX	2kV	Ext	2.7 to 5.25	1.8	N	SSOP-16	1.70
ADS7845	5-Wire	12(8)	Serial, SPI	X, Y, AUX	2kV	Ext	2.7 to 5.25	1.8	N	SSOP-16	4.20
ADS7846	4-Wire	12(8)	Serial, SPI	X, Y, Pressure, V _{BAT} , Temp, AUX	2kV	Int	2.7 to 5.25	1.8	N	SSOP-16, QFN-16, TSSOP-16, BGA-48	2.05
TSC2000	4-Wire	8, 10, 12	Serial, SPI	Processor, X, Y, Pressure, V _{BAT} , Temp, AUX, DAC	2kV	Int	2.7 to 3.6	6.2	N	TSSOP-16, QFN-16, BGA-48	2.55
TSC2003	4-Wire	12(8)	Serial, I ² C	X, Y, Pressure, V _{BAT} , Temp, AUX	2kV A, 2kV C	Int	2.7 to 5.25	1.8	N	TSSOP-16	2.25
TSC2004	4-Wire	12(10)	Serial, I ² C	Processor, X, Y, Pressure, Temp, AUX	18kV A, 15kV C	Ext	Analog: 1.2 to 3.6, V _{IO} : 1.2 to 3.6	0.075 (typ) Std 0.6, (typ) Enhanced	N	2.5x2.5 WCSP-18, QFN-20	2.00
TSC2005	4-Wire	12(10)	Serial, SPI	Processor, X, Y, Pressure, Temp, AUX	18kV A, 15kV C	Ext	Analog: 1.6 to 3.6, V _{IO} : 1.2 to 3.6	0.075 (typ) Std 0.6, (typ) Enhanced	N	2.5x3.0 WCSP-18	2.20
TSC2006	4-Wire	12(10)	Serial, SPI	Processor, X, Y, Pressure, Temp, AUX	18kV A, 15kV C	Ext	Analog: 1.2 to 3.6, V _{IO} : 1.2 to 3.6	0.075 (typ) Std 0.6, (typ) Enhanced	N	QFN-20	1.90
TSC2007	4-Wire	12(8)	Serial, I ² C	Processor, X, Y, Pressure, Temp, AUX	25kV A, 15kV C	V _{DD}	1.2 to 3.6	0.04 (typ)	N	1.5x2.0 WCSP-12, TSSOP-16	1.75
TSC2008	4-Wire	12(8)	Serial, SPI	Processor, X, Y, Pressure, Temp, AUX	25kV A, 15kV C	V _{DD}	1.2 to 3.6	0.04 (typ)	N	1.5x2.0 WCSP, QFN-16	1.75
TSC2014	4-Wire	12(10)	Serial, I ² C	Processor, X, Y, Pressure, Temp, AUX	18kV A, 15kV C	Ext	Analog: 1.2 to 3.6, V _{IO} : 1.2 to 3.6	0.075 (typ) Std 0.6, (typ) Enhanced	N	2.5x2.5 WCSP-18, QFN-20	2.00
TSC2046	4-Wire	12(8)	Serial, SPI	X, Y, Pressure, V _{BAT} , Temp, AUX	2kV A, 2kV C	Int	Analog: 2.2 to 5.25, V _{IO} : 1.5 to 5.25	1.8	Y	TSSOP-16, QFN-16, BGA-48	1.95
TSC2046E	4-Wire	12(8)	Serial, SPI	X, Y, Pressure, V _{BAT} , Temp, AUX	18kV A, 15kV C	Int	Analog: 2.2 to 5.25, V _{IO} : 1.5 to 5.25	0.7	N	TSSOP-16, QFN-16, BGA-48	2.20
TSC2200	4-Wire	8, 10, 12	Serial, SPI	Processor, X, Y, Pressure, V _{BAT} , Temp, KP, AUX, DAC	2kV	Int	2.7 to 3.6	6.2	N	TSSOP-16, QFN-16, BGA-48	2.60
TSC2017	4-Wire	12	Serial, I ² C	Processor, X, Y, Pressure, Temp, AUX	25kV A, 15kV C	V _{DD}	1.6 to 3.6	37μW	N	1.6mm x 1.6mm WCSP	1.95

*Suggested resale price in U.S. dollars in quantities of 1,000. See www.ti.com/hirel for HiRel options.

New products are listed in bold red.

→ Pulse-Width Modulation

Sensor Signal Conditioning IC for Closed-Loop Magnetic-Current Sensor

DRV401

Get samples and datasheets at: www.ti.com/sc/device/DRV401

Key Features

- Designed for sensors from Vacuumschmelze (VAC)
- Single supply: 5V
- Power output: H-bridge
- Designed for driving inductive loads
- Excellent precision
- Wide system bandwidth
- High-resolution, low-temperature drift
- Built-in degauss system
- Extensive fault detection
- External high-power driver option

Applications

- Generator/alternator monitoring and control
- Frequency and voltage inverters
- Motor drive controllers
- System power consumption
- Photovoltaic systems

The DRV401 is designed to control and process signals from specific magnetic current sensors made by Vacuumschmelze GmbH & Co. KG (VAC). A variety of current ranges and mechanical configurations are available. Combined with a VAC sensor, the DRV401 monitors both AC and DC currents to high accuracy.

Provided functions include: probe excitation, signal conditioning of the probe signal, signal loop amplifier, an H-bridge driver for the compensation coil and an analog signal output stage that provides an output voltage proportional to the primary current. It offers overload and fault detection, as well as transient noise suppression.

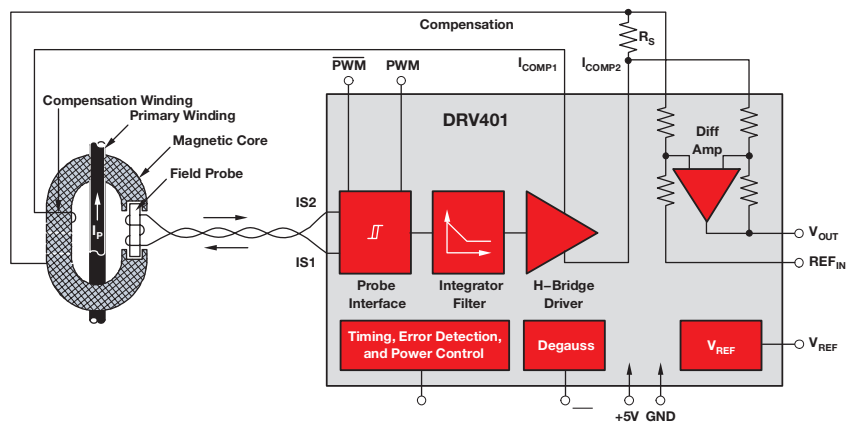

DRV401 functional block diagram (patent pending)

PWM Power Drivers

Device	Description	Supply Voltage (V)	Output Current (A) (typ)	Saturation Voltage (V)	R _{ON} (Ω)	Frequency (kHz)	HiRel Avail.	Package(s)	Price*
Single Switch									
DRV101	Low-Side with Internal Monitoring	9 to 60	2.3	1	0.8	24	N	TO-220, DDPACK	3.85
DRV102	High-Side with Internal Monitoring	8 to 60	2.7	2.2	0.95	24	N	TO-220, DDPACK	3.85
DRV103	Low-Side with Internal Monitoring	8 to 32	1.5/3	0.6	0.9	0.5 to 100	N	SOIC-8, SOIC-8 PowerPAD™	2.00
DRV104	High-Side with Internal Monitoring	8 to 32	1.2	0.65	0.45	0.5 to 100	N	HTSSOP-14 PowerPAD	1.75
Bridge									
DRV590	1.2A, High-Efficiency PWM Power Driver	2.7 to 5.5	1.2	0.48	0.4	250/500	N	SOIC-PowerPAD, 4mm x 4mm MicroStar Junior™	12.00
DRV591	±3A, High-Efficiency PWM Power Driver	2.8 to 5.5	3	0.195	0.065	100/500	N	9x9 PowerPAD QFP	11.00
DRV592	±3A, High-Efficiency H-Bridge	2.8 to 5.5	3	0.195	0.065	1000	N	9x9 PowerPAD QFP	2.85
DRV593	±3A, High-Efficiency PWM Power Driver	2.8 to 5.5	3	0.195	0.065	100/500	N	9x9 PowerPAD QFP	10.80
DRV594	±3A, High-Efficiency PWM Power Driver	2.8 to 5.5	3	0.195	0.065	100/500	N	9x9 PowerPAD QFP	10.80
Sensor Signal Conditioning									
DRV401	Signal Cond. for Magnetic-Current Sensor	4.5 to 5.5	0.2	0.4	—	2000	Y	QFN-20, SOIC-20	2.05

*Suggested resale price in U.S. dollars in quantities of 1,000. See www.ti.com/hirel for HiRel options.

New products are listed in bold red.

→ Current Shunt Monitors

Chip-Scale, Low-Power Unidirectional Current Shunt Monitor

INA216

Get samples and datasheets at: www.ti.com/sc/device/INA216a1

Key Features

- High accuracy
 - Voltage offset: 30 μ V (typ), 100 μ V (max)
 - Offset drift: 0.05 μ V/ $^{\circ}$ C (max)
 - 0.2% gain error (max)
 - CMRR: 90dB (min)
 - 20mV total error (max)
- 25 μ A (max) supply current
- 0.8mm x 0.8mm WCSP
- CM and supply voltage range +1.8V to +5.5V

Applications

- Cell phones
- GPS
- Handheld radios
- Notebooks/netbooks/tablets

The INA216 is a high-side voltage-output current shunt monitor that can sense drops across shunts at common-mode voltages from +1.8V to +5.5V. Four fixed gains are available: 25V/V, 50V/V, 100V/V and 200V/V. The low offset of the zero-drift architecture enables current sensing with maximum drops across the shunt as low as 10mV full-scale, or with wide dynamic ranges of more than 1000:1. These devices operate from a single +1.8V to +5.5V power supply, drawing a maximum of 25mA of supply current. The INA216 series are specified over the temperature range of -40° C to $+125^{\circ}$ C, and offered in a chip-scale package.

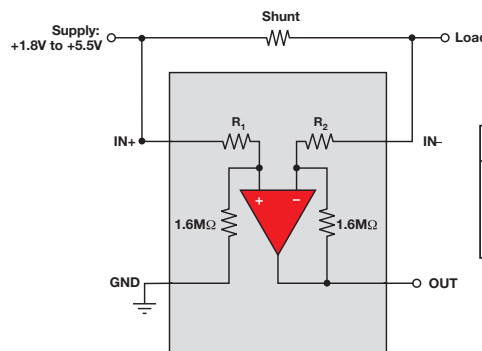

PRODUCT	GAIN	R ₁ = R ₂
INA216A1	25	64k Ω
INA216A2	50	32k Ω
INA216A3	100	16k Ω
INA216A4	200	8k Ω

INA216 functional block diagram

Bidirectional Current/Power Monitor with I²C

INA220

Get samples, datasheets and EVMs at: www.ti.com/sc/device/INA220

Key Features

- Low or high-side sensing
- Bidirectional
- Sense current, voltage and power over I²C
- -0.3 to 26V common-mode range
- Accuracy: $\pm 1\%$ (max) over -25° C to $+85^{\circ}$ C
- 100 μ V offset (max) and 40mV FSR
- +3V to +5.5V supply voltage
- 12-bit resolution
- Programmable filtering
- Programmable calibration register

Applications

- Servers
- Telecom equipment
- Automotive
- Power management
- Battery chargers
- Power supplies
- Test equipment

The INA220 is a current shunt and power monitor with a two-wire interface. The INA220 monitors both shunt drop and supply voltage. A programmable calibration value, combined with an internal multiplier, enables direct readouts in amperes. An additional multiplying register calculates power in Watts. The two-wire interface features 16 programmable addresses. The separate shunt input on the INA220 allows it to be used in systems with low-side sensing.

The INA220 senses across shunts on buses that can vary from 0V to 26V, useful for low-side sensing or CPU power supplies. The device uses a single +3V to +5.5V supply, drawing a maximum of 1mA of supply current. The INA220 operates from -40° C to $+125^{\circ}$ C.

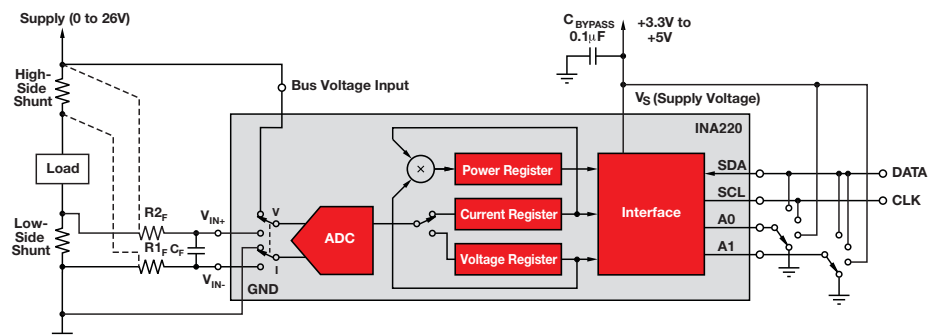

INA220 functional block diagram

Monitoring and Control

→ Current Shunt Monitors

Current Shunt Monitors

Device	Description	Gain (V/V)	Offset (μV) (max)	Offset Drift (μV/°C) (max)	CMRR (dB) (typ)	BW (kHz) (typ)	Output Voltage Swing (V) (min)	Power Supply (V)	I _Q (mA) (max)	HiRel Avail.	Package(s)	Price*
Voltage-Output, High-Side Current Shunt Monitors												
INA19x	-16V to +80V CMV	20, 50, 100	2000	2.5	120	500, 300, 200	V(+)-0.2	2.7 to 18	0.9	Y	SOT-23-5	0.80
INA20x	Dual Comparator, 1.2V V _{REF} -16V to +18V CMV	20, 50, 100	2500	3.5	123	500, 300, 200	V(+)-0.25	2.7 to 18	2.2	N	TSSOP/SO-14, MSOP-10, MSOP/SO/DFN-8	0.45
INA27x	-16V to +18V CMV, Filtering Provision	14, 20	2000	2.5	120	130	V(+)-0.2	2.7 to 18	0.9	Y	SO-8	0.40
Current-Output, High-Side Current Shunt Monitors												
INA138	+2.7V to 36V CMV Range	1 to 100	1000	1	120	800	0 to V(+)-0.8	2.7 to 36	0.045	Y	SOT-23-5	0.65
INA168	+2.7V to 60V CMV Range	1 to 100	1000	1	120	800	0 to V(+)-0.8	2.7 to 60	0.045	Y	SOT-23-5	0.80
INA139	+2.7 to 40V CMV Range	1 to 100	1000	1	115	440	0 to V(+)-1.2	2.7 to 40	0.125	Y	SOT-23-5	0.65
INA169	+2.7 to 60V CMV Range	1 to 100	1000	1	120	440	0 to V(+)-1.2	2.7 to 60	0.125	Y	SOT-23-5	0.80
Bidirectional Current Shunt Monitors												
INA170	+2.7 to 60V CMV	1 to 100	1000	1	120	440	0 to V(+)-1.2	2.7 to 40	0.125	N	MSOP-8	0.95
INA209	Voltage Current, Power Over I ² C, 0 to +26V CMV	1, 2, 4, 8	100	0.1	120	—	—	3 to 5.5	1.5	N	TSSOP-16	2.50
INA219	Low Cost, Voltage Current, Power Over I ² C, 0 to +26V CMV	1, 2, 4, 8	100	0.1	120	—	—	3 to 5.5	1.5	N	SOT-23-8	0.99
INA21x	Zero Drift, Bidirectional, -0.3V to +26V CMV	50, 100, 200, 500, 1000	35	0.5	140	14	V(+)-0.1	2.7 to 26	0.1	Y	SC-70	0.65
INA28x	Zero Drift, Bidirectional, -16V to +80V CMV	50, 100, 200, 500, 1000	10	0.05	100	14	V(+)-0.1	2.7 to 18	0.9	N	SO-8, DFN-10	0.95
INA220	High-or Low-Side I ² C Current/Power Monitor, 0 to +26 V CMV	1, 2, 4, 8	100	0.16	120	—	—	3 to 5.5	1	N	MSOP-10	0.99
INA199	Zero Drift, High or Low Side Current Monitor, -0.3V to +26V CMV	50, 100, 200	150	0.5	120	14	V(+)-0.2	2.7 to 26	0.1	N	SC-70, QFN-10	0.50
TMP512/513	High-Side I ² C Monitor with Integrated Temp Sensor	1, 2, 4, 8	100	0.2	120	—	—	3 to 26	1.4	N	SO-14, SO-16	1.45

*Suggested resale price in U.S. dollars in quantities of 1,000. See www.ti.com/hirel for HiRel options.

New products are listed in bold red.

→ Temperature Sensors

High-Accuracy, Low-Power, Digital Temp Sensor

TMP112

Get samples and datasheets at: www.ti.com/sc/device/TMP112

Key Features

- Accuracy:
 - ±1.0°C (max) from -40°C to +125°C
 - ±0.5°C (max) from 0°C to +65°C
- $V_s = 1.4V$ to 3.6V
- Power = 10µA active, 1µA shutdown
- Ultra-small SOT563 package (1.6mm x 1.6mm)

Applications

- Digital alternative to thermistors
- Portable medical and metering
- Cold junction compensation
- Green energy controls
- Pharmaceutical and food monitoring

The TMP112 leads the industry in digital temperature sensor accuracy, low power and package size. The performance of the TMP112 offers accuracy of ±0.5°C and a resolution of 0.0625°C, making it easy to achieve precision thermal management out of the box. The additional calibrated drift slope specification allows designers to achieve even better than ±0.5°C accuracy over user-specified temperature ranges with a single-point calibration technique, making the TMP112 the highest accuracy digital temperature sensor in the world and bringing new flexibility to portable design.

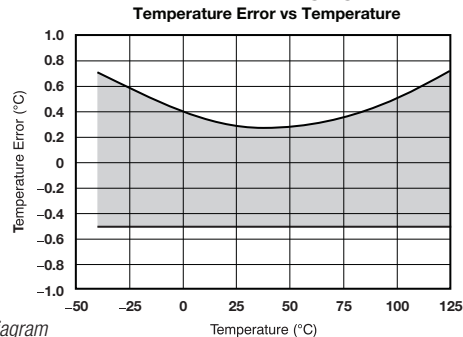

TMP112 functional block diagram

Remote Temperature Sensors

Device	Description	Feature	Remote Sensor Accuracy Over Temp Range (°C) (max)	Local Sensor Accuracy Over Temp Range (°C) (max)	Remote Sensor Temp Range (°C)	Supply Voltage (V)	I_Q (µA) (typ)	HiRel Avail.	Package(s)	Price*
TMP400	Remote and Local Temp Sensor with Programmable Non-Ideality Factor	n-Factor Correction, Series Resistance Cancellation, Alert Flag	1	2.5	-40 to +125	2.7 to 5.5	420	N	QSSOP-16	0.85
TMP401	Programmable Remote and Local Temperature Sensor	Series Resistance Cancellation, Fault Detection, Alert Flag	1	3	-40 to +150	3.0 to 5.5	350	N	MSOP-8	0.85
TMP411	Remote and Local Temp Sensor with Programmable Non-Ideality Factor	n-Factor Correction, Series Resistance Cancellation, Fault Detection, Alert Flag	1	2.5	-40 to +150	2.7 to 5.5	350	N	MSOP-8	0.45
TMP421	Remote and Local Temp Sensor in SOT-23-8	n-Factor Correction, Series Resistance Cancellation, Fault Detection	1	2	-40 to +150	2.7 to 5.5	400	N	SOT-23-8	0.55
TMP422	2x Remote and Local Temp Sensor in SOT-23-8	n-Factor Correction, Series Resistance Cancellation, Fault Detection	1	2	-40 to +150	2.7 to 5.5	400	N	SOT-23-8	0.65
TMP423	3x Remote and Local Temp Sensor in SOT-23-8	n-Factor Correction, Series Resistance Cancellation, Fault Detection	1	2	-40 to +150	2.7 to 5.5	400	N	SOT-23-8	0.75
TMP431	Remote and Local Temp Sensor with Programmable n-Factor and Beta Correction	Beta Correction, n-Factor Correction, Series Resistance Cancellation, Fault Detection, Alert Flag	1	2.5	-40 to +150	2.7 to 5.5	700	N	MSOP-8	0.45
TMP432	2x Remote and Local Temp Sensor with Programmable n-Factor and Beta Correction	Beta Correction, n-Factor Correction, Series Resistance Cancellation, Fault Detection, Alert Flag	1	2.5	-40 to +150	2.7 to 5.5	700	N	MSOP-10	0.55
TMP435	Programmable Addresss Remote and Local Temp Sensor	Beta Correction, n-Factor Correction, Series Resistance Cancellation, Fault Detection, Alert Flag	1	2.5	-40 to +150	2.7 to 5.5	700	N	MSOP-10	0.60
TMP441	Remote and Local Temp Sensor with Beta Correction in SOT-23-8	Beta Correction, n-Factor Correction, Series Resistance Cancellation, Fault Detection	1	2	-40 to +150	2.7 to 5.5	400	N	SOT-23-8	0.55
TMP442	2x Remote and Local Temp Sensor with Beta Correction in SOT-23-8	Beta Correction, n-Factor Correction, Series Resistance Cancellation, Fault Detection	1	2	-40 to +150	2.7 to 5.5	400	N	SOT-23-8	0.65
TMP512	2x Remote and Local Temp Sensor with Integrated Current Shunt	Beta Correction, n-Factor Correction, Series Resistance Cancellation, Fault Detection, Alert Flag	1	2.5	-40 to +150	3 to 26	1000	N	S0-14	1.45
TMP513	3x Remote and Local Temp Sensor with Integrated Current Shunt	Beta Correction, n-Factor Correction, Series Resistance Cancellation, Fault Detection, Alert Flag	1	2.5	-40 to +150	3 to 26	1000	N	S0-16	1.55

*Suggested resale price in U.S. dollars in quantities of 1,000.

New products are listed in bold red.

Monitoring and Control

→ Temperature Sensors

Temperature Sensors

Device	Description	Accuracy Over Temp Range (°C) (max)	Specified Temp Range (°C)	Temp Resolution (Bits)	Supply Voltage (V)	I _Q (μA) (typ)	HiRel Avail.	Package(s)	Price*
I²C/SMBus Interface									
TMP20	Analog Output Temperature Sensor	2.5	-55 to +130	N/A	2.7 to 5.5	2.6	N	SOT563-6, SC70	0.30
TMP100	Digital Temp Sensor	2, 3	-25 to +85 -55 to +125	9 to 12	2.7 to 5.5	45	Y	SOT-23-6	0.75
TMP101	Digital Temp Sensor with Prog. Thermostat/Alarm Function	2, 3	-25 to +85 -55 to +125	9 to 12	2.7 to 5.5	45	N	SOT-23-6	0.80
TMP102	Ultra-Low-Power Digital Temp Sensor in Micro Surface Mount Pkg.	2, 3	-25 to 85 -40 to 125	12	1.4 to 3.6	7	N	SOT563-6	0.80
TMP105	Chipscale Digital Temp Sensor with 1.8V to 3.0V Logic	2, 3	-25 to +85 -40 to +125	9 to 12	2.7 to 5.5	50	N	1mm x 1.5mm WCSP-6	0.85
TMP106	Chipscale Digital Temp Sensor with 2.7V to 5.0V Logic	2, 3	-25 to +85 -40 to +125	9 to 12	2.7 to 5.5	50	N	1mm x 1.5mm WCSP-6	0.85
TMP112	Ultra-Low-Power, High-Accuracy Digital Temp Sensor in SOT563 package	0.5, 1	0 to 65 -40 to +125	12	1.4 to 3.6	7	N	SOT563-6	0.85
TMP275	Ultra-High-Accuracy Digital Temp Sensor	0.5, 1	+10 to +85 -40 to +125	9 to 12	2.7 to 5.5	50	N	MSOP-8, SOIC-8	1.25
TMP175	Digital Temp Sensor with 2-Wire Interface, 27 Addresses	1.5, 2	-25 to +85 -40 to +125	9 to 12	2.7 to 5.5	50	N	MSOP-8, SOIC-8	0.85
TMP75	Industry-Standard Sensor with 2-Wire Interface, 8 Addresses	2	-25 to +85	9 to 12	2.7 to 5.5	50	N	MSOP-8, SOIC-8	0.70
SPI™ Interface									
TMP121	1.5°C Accurate Digital Temp Sensor with SPI Interface	1.5, 2	-25 to +85 -40 to +125	12	2.7 to 5.5	35	Y	SOT-23-6	0.90
TMP122	1.5°C Accurate Programmable Temp Sensor with SPI Interface	1.5, 2	-25 to +85 -40 to +125	9 to 12	2.7 to 5.5	50	Y	SOT-23-6	0.99
TMP123	1.5°C Accurate Digital Temp Sensor with SPI Interface	1.5, 2	-25 to +85 -55 to +125	12	2.7 to 5.5	35	N	SOT-23-6	0.90
TMP124	1.5°C Accurate Programmable Temp Sensor with SPI Interface	1.5, 2	-25 to +85 -40 to +125	9 to 12	2.7 to 5.5	50	N	SOIC-8	0.70
TMP125	2°C Accurate Digital Temp Sensor with SPI Interface	2, 2.5	-25 to +85 -40 to +125	10	2.7 to 5.5	36	N	SOT-23-6	0.80
Single-Wire, SensorPath Interface									
TMP141	Digital Temp Sensor with Single-Wire SensorPath Bus	2, 3	-25 to +85 -40 to +125	10	2.7 to 5.5	110	N	SOT-23-6, MSOP-8	0.80

Temperature Switches

Device	Description	Trip Point Accuracy (°C) (typ)	Hysteresis (°C)	Specified Temp Range (°C)	Supply Voltage (V)	I _Q (μA) (max)	HiRel Avail.	Package(s)	Price*
TMP300	Comparator-Output Temperature Switch with Additional Analog Output	±2	5 or 10	-40 to +125	1.8 to 18	110	N	SC70-6, SOT-23-6	0.50
TMP302	Low-Power, High-Accuracy Temperature Switch	±0.2	5 or 10	-40 to +125	1.4 to 3.6	15	N	SOT-563	0.30
TMP303	Low-Power, High-Accuracy Temperature Switch with Push-Pull Output	±0.2	1, 2, 5 or 10	-40 to +125	1.4 to 3.6	15	N	SOT-563	0.30

Fan Controllers

Device	Description	Accuracy (°C) (typ)	Input	Fan Control Modes	Output	I _Q (mA)	Supply Voltage (V)	Interface	HiRel Avail.	Package	Price*
AMC6821	±1°C Remote and Local Temp Sensors with Integrated Fan Controller	±1	1 Local and 1 Remote Temp	Programmable, Automatic and Fixed RPM	Programmable PWM Frequency and Duty Cycle	2 (Active)	2.7 to 5.5	I ² C/SMBus	Y	SOP-16 4mm x 5mm	0.99

*Suggested resale price in U.S. dollars in quantities of 1,000. See www.ti.com/hirel for HiRel options.

New products are listed in bold red.

→ 4-20mA Transmitters

Precision Voltage-to-Current Converter/Transmitter

XTR111

Get samples, datasheets, evaluation modules and app reports at: www.ti.com/sc/device/XTR111

Key Features

- Wide supply range: 7V to 44V
- Current or voltage output
- Accuracy: 0.015%
- Output error detection and disable
- Adjustable 3V to 15V sub-regulator
- Nonlinearity: 0.002%
- Offset drift: 1μV/°C
- Low supply current: 550μA
- Packaging: DFN-10, MSOP PowerPAD™

Applications

- Universal voltage-controlled current source
- Current or voltage output for 3-wire sensor systems
- PLC output programmable drivers
- Current-mode sensor excitation

The XTR111 is a precision voltage-to-current converter designed for standard 0-20mA or 4-20mA analog signals and can source up to 36mA. It is ideal for 3-wire sensors and for the analog outputs of control systems like programmable logic controllers (PLCs). Sensor excitation and common voltage-to-current (source) applications will benefit from its high accuracy (0.015%).

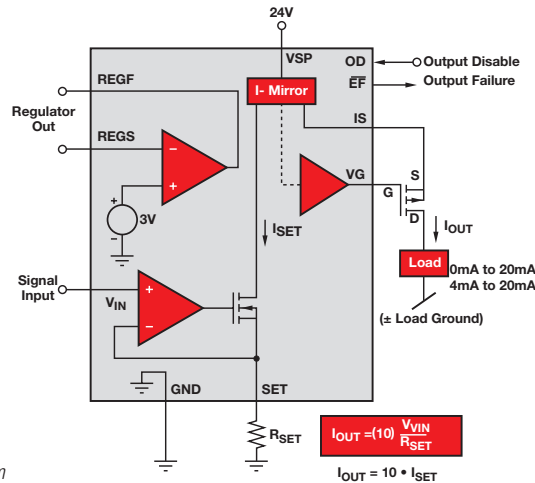

4-20mA Transmitters and Receivers

Device	Description	Sensor Excitation	Loop Voltage (V)	Full-Scale Input Range	Output Range (mA)	Additional Power Available (V at mA)	HiRel Avail.	Package(s)	Price*
2-Wire, 4-20mA Transmitters									
XTR105	100Ω RTD Conditioner with Linearization	Two 800μA	7.5 to 36	5mV to 1V	4-20	5.1 at 0.5	N	DIP-14, SOIC-14	4.60
XTR106	Bridge Conditioner with Linearization	5V and 2.5V	7.5 to 36	5mV to 1V	4-20	5.1 at 1	N	DIP-14, SOIC-14	4.00
XTR108	10Ω to 10kΩ RTD Conditioner, 6-Channel Input MUX, Extra Op Amp Can Convert to Voltage Sensor Excitation, Calibration Stored in External EEPROM	Two 500μA	7.5 to 24	5mV to 320mV	4-20	5.1 at 2.1	N	SSOP-24	3.35
XTR112	1kΩ RTD Conditioner with Linearization	Two 250μA	7.5 to 36	5mV to 1V	4-20	5.05 at 1	N	SOIC-14	4.00
XTR114	10kΩ RTD Conditioner with Linearization	Two 100μA	7.5 to 36	5mV to 1V	4-20	5.05 at 1	N	SOIC-14	4.00
XTR115	I _{IN} to I _{OUT} Converter, External Resistor Scales V _{IN} to I _{IN}	V _{REF} = 2.5V	7.5 to 36	40μA to 250μA	4-20	4.9 at 1	N	SOIC-8	1.25
XTR116	I _{IN} to I _{OUT} Converter, External Resistor Scales V _{IN} to I _{IN}	V _{REF} = 4.096V	7.5 to 36	40μA to 250μA	4-20	4.9 at 1	N	SOIC-8	1.05
XTR117	Current Loop, 7.5 to 40V, 5V Voltage Regulator	V _{REG} = 5V	7.5 to 40	40μA to 250μA	4-20	4.9 at 1	N	MSOP-8, DFN-8	0.90
Bridge Conditioner with Digital Calibration for Linearization, Span and Offset Over Temperature									
PGA309	Complete Digitally Calibrated Bridge Sensor Conditioner, Voltage Output, Calibration Stored in External EEPROM, One-Wire/Two-Wire Interface	V _{EXC} = V _S , 2.5V 4.096V	2.7 to 5.5	1mV/V to 245mV/V	0.05V-4.9V at V _S = +5V	—	N	TSSOP-16	2.95
PGA308	Single Supply, Auto-Zero, Sensor Amplifier with Programmable Gain and Offset	—	2.7 to 5.5	0.2V to 4.1V	0.03V to 5.44mA at V _S = +5V	—	N	MSOP-10, DFN-10	2.00
Industrial Current/Voltage Drivers									
XTR110	Precision V-to-I Converter/Transmitter, Selectable I/O Ranges	V _{REF} = 10V	13.5 to 40	0V to 5V, 0V to 10V	0-20, 4-20, 5-20	—	N	DIP-16, SOL-16	7.10
XTR111	Precision V-to-I Converter/Transmitter, Adjustable V _{REG} , 3V to 15V	V _{REG} = 3 to 15V	8 to 40	0V to 12V	0-20, 4-20, 5-20	3V to 15V	N	DFN/MSOP-10	1.10
XTR300	Industrial Analog Current/Voltage Output Driver	—	<34	V(-)+3 to V(+)-3 Prog V _{OUT}	±17V ±24mA	—	N	5x5 QFN/TSSOP-20	2.45
4-20mA Current Loop Receiver									
RCV420	4-20mA Input, 0V to 5V Output, 1.5V Loop Drop	V _{REF} = 10V	+11.5/-5 to ±18	4-20mA	0V to 5V	—	N	DIP-16	3.55

*Suggested resale price in U.S. dollars in quantities of 1,000.

New products are listed in bold red.

→ Voltage References

3ppm/°C Drift, 0.05% Accurate, Low-Noise, Precision Series Voltage References

REF5020, REF5025, REF5030, REF5040, REF5045, REF5050, REF5010

Get samples, datasheets and app reports at: www.ti.com/sc/device/PARTnumber (Replace **PARTnumber** with **REF5020**, **REF5025**, **REF5030**, **REF5040**, **REF5045**, **REF5050** or **REF5010**)

Key Features

- High accuracy: 0.05%
- Low temperature drift: 3ppm/°C (max)
- Very low noise: $3\mu\text{V}_{\text{PP}}/\text{V}$
- High output current: $\pm 10\text{mA}$
- Wide supply range: 2.7V to 18V
- Industrial temperature range: -40°C to $+125^\circ\text{C}$
- Packaging: SO-8, MSOP coming soon

Applications

- Test and measurement
- 16-bit data acquisition systems
- Medical and patient monitoring
- Industrial process control

The REF50xx brings a new level of precision to the TI series voltage reference line. Offering 3ppm/°C (max) drift and 0.05% initial accuracy and very low noise, the REF50xx is designed for industrial, medical and test applications that require performance over temperature.

Model	Voltage Out
REF5020	2.048V
REF5025	2.5V
REF5030	3.0V
REF5040	4.096V
REF5045	4.5V
REF5050	5V
REF5010	10V

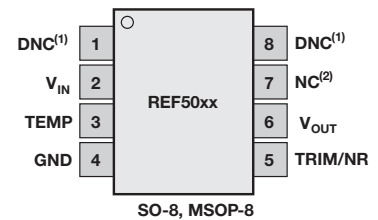

REF50xx package diagram

Voltage References

Device	Description	Output (V)	Initial Accuracy (%) (max)	Drift (ppm/°C) (max)	Long-Term Stability (ppm/1000hr) (typ)	Noise 0.1 to 10Hz ($\mu\text{Vp-p/V}$) (typ)	I_0 (mA) (max)	Temperature Range (°C)	Output Current (mA)	HiRel Avail.	Package(s)	Price*
REF50xx	High Accuracy Bandgap Reference	2.048, 2.5, 3.0, 4.096, 4.5, 5, 10	0.05	3	5	3	1	-40 to $+125$	± 10	Y	SOIC-8	2.95
REF50xxA	High Accuracy Bandgap Reference	2.048, 2.5, 3.0, 4.096, 4.5, 5, 10	0.1	8	5	3	1	-40 to $+125$	± 10	Y	SOIC-8	1.35
REF33xx	microPower, Tiny Bandgap	1.25, 1.8, 2.048, 2.5, 3.0, 3.3	0.15	30	—	28	0.005	-40 to $+125$	± 5	N	SC-70, SOT-23-3	0.85
REF32xx	Low Drift, Low Power, Small Bandgap	1.25, 2.048, 2.5, 3.0, 3.3, 4.096	0.2	7	55	13	0.120	-40 to $+125$	± 10	Y	SOT-23-6	1.70
REF31xx	Series Bandgap	1.25, 2.048, 2.5, 3.0, 3.3, 4.096	0.2	15	70	13	0.115	-40 to $+125$	± 10	N	SOT-23-3	1.10
REF30xx	Series Bandgap	1.25, 2.048, 2.5, 3.0, 3.3, 4.096	0.2	50	24	11	0.05	-40 to $+125$	25	Y	SOT-23-3	0.60
REF29xx	Series Bandgap	1.25, 2.048, 2.5, 3.0, 3.3, 4.096	2	100	24	11 to 16	0.05	-40 to $+125$	25	N	SOT-23-3	0.49
REF02A	Low Drift, Buried Zener	5	0.3	15	50	0.8	1.4	-40 to $+85$	$+21, -0.5$	N	SOIC, PDIP	1.45
REF02B	Low Drift, Buried Zener	5	0.2	10	50	0.8	1.4	-40 to $+85$	$+21, -0.5$	N	SOIC, PDIP	2.05
REF102A	Low Drift, Buried Zener	10	0.1	10	20	0.5	1.4	-25 to $+85$	$+10, -5$	N	SOIC, PDIP	1.75
REF102B	Low Drift, Buried Zener	10	0.05	5	20	0.5	1.4	-25 to $+85$	$+10, -5$	N	SOIC, PDIP	3.25
REF102C	Ultra-Low Drift, Buried Zener	10	0.025	2.5	20	0.5	1.4	-25 to $+85$	$+10, -5$	N	SOIC, PDIP	4.50
Shunt												
REF1112	μPower , 1.25V Shunt	1.25	0.2	30	60	20	0.0015	-40 to $+125$	0.0012 to 5	N	SOT-23-3	0.85
Current Reference												
REF200	Dual-Current Reference with Current Mirror	100 μA /Channel	± 1	25 (typ)	—	1nAp-p	—	-25 to $+85$	50 μA to 400 μA	N	PDIP-8, SOIC-8	2.60

*Suggested resale price in U.S. dollars in quantities of 1,000. See www.ti.com/hirel for HiRel options.

New products are listed in bold red.

→ Clock Distribution (Fan-Out Clock Buffers, Zero-Delay Buffers)

Clock Distribution

CDCLVC11xx

NEW

Get samples and datasheets at: www.ti.com/sc/device/CDCLVC1102

Key Features

- Family of high-performance 1:2/3/4/6/8/10/12 LVCMOS clock fan-out buffers
- Very low pin-to-pin skew <50ps
- Very low additive jitter <100fs RMS (12kHz to 20MHz)
- Supply voltage: 3.3V or 2.5V
- $f_{max} = 250\text{MHz}$ for 3.3V
- $f_{max} = 180\text{MHz}$ for 2.5V
- Operating temperature range: -40°C to $+85^{\circ}\text{C}$
- Available in 8-, 14-, 16-, 20-, 24-pin TSSOP package (all pin-compatible)

Applications

- General purpose communication, Industrial and consumer applications

The CDCLVC11xx is a modular, high-performance, low-skew, general-purpose clock buffer family designed with a modular approach in mind. There are 7 different Fan-Out variations, (1:2 to 1:12) available. All of the devices are pin-compatible to each other for easy handling. All family members share the same high-performing characteristics like low additive jitter, low skew and wide operating temperature range. The CDCLVC11xx supports an asynchronous output enable control (1G) that switches the outputs into a low state when 1G is low.

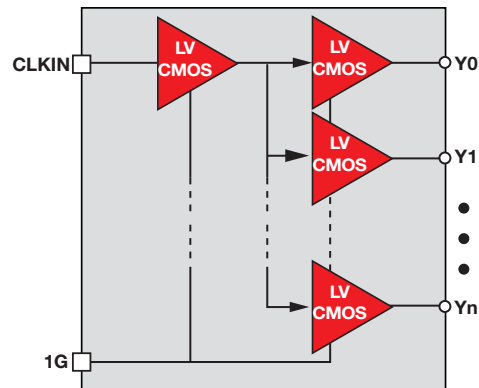

CDCLVC11xx functional block diagram

NEW

Clock Distribution

CDCLVD12xx/21xx

Get samples and datasheets at: www.ti.com/sc/device/CDCLVD1204

Key Features

- Family of high-performance 2:4/8/12/16 or dual 1:2/4/6/8 universal-to-LVDS clock fan-out buffers
- Very low additive jitter <300fs RMS (10kHz-20MHz)
- Low output skew of 20ps (max)
- Universal inputs accept LVDS, LVPECL and LVCMOS
- Selectable clock inputs – control pin
- LVDS outputs, ANSI EAI/TIA-644A standard-compatible
- Clock frequency up to 800MHz
- 2.375V to 2.625V device power supply
- LVDS ref voltage, V_{AC_REF} , available for capacitive coupled inputs
- Industrial temp range: -40°C to $+85^{\circ}\text{C}$

Applications

- Telecommunications/networking
- Medical imaging
- Test and measurement equipment
- Wireless communications
- General-purpose clocking

The CDCLVD12xx/21xx clock buffers distribute one or two selectable clock inputs, (IN0, IN1), to 4, 8, 12 or 16 pairs of differential LVDS clock outputs (OUT0, OUT3) with minimum skew for clock distribution. The buffers can accept two clock sources into an input multiplexer. The inputs can either be LVDS, LVPECL or LVCMOS.

The CDCLVD12xx/21xx are specifically designed for driving 50 transmission lines. When driving the inputs in single-ended mode, the appropriate bias voltage (V_{AC_REF}) should be applied to the unused negative input pin.

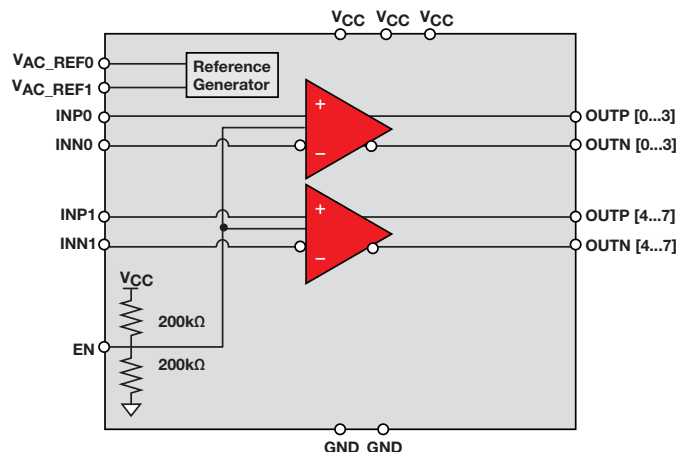

CDCLVD12xx/21xx functional block diagram

Clocks and Timing

→ Clock Distribution (Fan-Out Clock Buffers, Zero Delay Buffers)

Clock Distribution

CDCLVP12xx/21xx

NEW

Get samples and datasheets at: www.ti.com/sc/device/CDCLVP1204

Key Features

- Family of high-performance 2:4/8/12/16 or dual 1:2/4/6/8 universal-to-LVPECL clock fan-out buffers
- Universal inputs accept LVPECL, LVDS and LVCMOS/LVTTL
- Maximum clock frequency: 2GHz
- Very low additive jitter <100fs RMS (10kHz-20MHz)
- 2.375-V to 3.6-V device power supply
- Low output skew of 30ps (max)
- LVPECL reference voltage, V_{AC_REF}
- Available for capacitive-coupled inputs
- Industrial temperature range: -40°C to +85°C

Applications

- Wireless communications
- Telecommunications/networking
- Medical imaging
- Test and measurement equipment

The CDCLVP12xx/21xx are highly versatile, low additive jitter buffers that can generate up to 16 copies of LVPECL clock outputs from one of two selectable LVPECL, LVDS or LVCMOS inputs for a variety of communication applications. The devices have a maximum clock frequency up to 2GHz. The CDCLVP12xx/21xx feature an on-chip multiplexer (MUX) for selecting one of two inputs that can be easily configured solely through a control pin. The overall additive jitter performance is <100fs RMS (10kHz to 20MHz) and overall output skew is as low as 30ps, making the device a perfect choice for use in demanding applications.

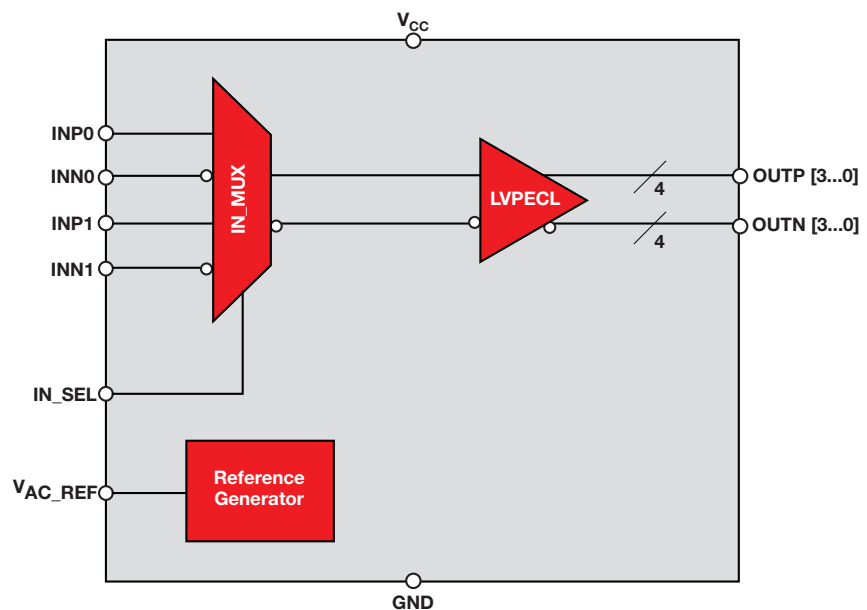

CDCLVP12xx/21xx functional block diagram

Clocks and Timing

→ Clock Distribution (Fan-Out Clock Buffers, Zero-Delay Buffers)

Clock Distribution

Device	Description	Input Level	Output Level	Frequency (MHz)	V _{CC} (V)	Propagation Delay	Output Skew (max) (ps)	Char. Temp. (°C)	HiRel Avail.	Package(s)	Price*
Fan-Out Clock Buffers (Non-PLL)											
Differential-Ended											
CDCLVP1102	Low-Jitter 1:2 Universal-to-LVPECL Buffer	LVPECL/LVDS/LVCMOS	LVPECL	0 to 2GHz	2.5/3.3	450ps (max)	10ps	-40 to 85	N	QFN-16	2.50
CDCLVP1204	Low-Jitter, 2-Input Selectable 1:4 Universal-to-LVPECL Buffer	LVPECL/LVDS/LVCMOS	LVPECL	0 to 2GHz	2.5/3.3	450ps (max)	15ps	-40 to 85	N	QFN-16	3.30
CDCLVP1208	Low-Jitter, 2-Input Selectable 1:8 Universal-to-LVPECL Buffer	LVPECL/LVDS/LVCMOS	LVPECL	0 to 2GHz	2.5/3.3	450ps (max)	20ps	-40 to 85	N	QFN-28	5.00
CDCLVP1212	Low-Jitter, 2-Input Selectable 1:12 Universal-to-LVPECL Buffer	LVPECL/LVDS/LVCMOS	LVPECL	0 to 2GHz	2.5/3.3	550ps (max)	25ps	-40 to 85	N	QFN-40	6.50
CDCLVP1216	Low-Jitter, 2-Input Selectable 1:16 Universal-to-LVPECL Buffer	LVPECL/LVDS/LVCMOS	LVPECL	0 to 2GHz	2.5/3.3	550ps (max)	30ps	-40 to 85	N	QFN-48	8.50
CDCLVP2102	Low-Jitter, Dual 1:2 Universal-to-LVPECL Buffer	LVPECL/LVDS/LVCMOS	LVPECL	0 to 2GHz	2.5/3.3	450ps (max)	10ps (Within Bank)	-40 to 85	N	QFN-16	3.30
CDCLVP2104	Low-Jitter, Dual 1:4 Universal-to-LVPECL Buffer	LVPECL/LVDS/LVCMOS	LVPECL	0 to 2GHz	2.5/3.3	450ps (max)	15ps (Within Bank)	-40 to 85	N	QFN-28	5.00
CDCLVP2106	Low-Jitter, Dual 1:6 Universal-to-LVPECL Buffer	LVPECL/LVDS/LVCMOS	LVPECL	0 to 2GHz	2.5/3.3	550ps (max)	20ps (Within Bank)	-40 to 85	N	QFN-40	6.50
CDCLVP2108	Low-Jitter, Dual 1:8 Universal-to-LVPECL Buffer	LVPECL/LVDS/LVCMOS	LVPECL	0 to 2GHz	2.5/3.3	550ps (max)	25ps (Within Bank)	-40 to 85	N	QFN-48	8.50
CDCLVD1204	Low-Jitter, 2-Input Selectable 1:4 Universal-to-LVDS Buffer	LVPECL/LVDS/LVCMOS	LVDS	0 to 800	2.5	1.5ns (typ)	20ps	-40 to 85	N	QFN-16	2.85
CDCLVD1208	Low-Jitter, 2-Input Selectable 1:8 Universal-to-LVDS Buffer	LVPECL/LVDS/LVCMOS	LVDS	0 to 800	2.5	1.5ns (typ)	20ps	-40 to 85	N	QFN-28	3.85
CDCLVD1212	Low-Jitter, 2-Input Selectable 1:12 Universal-to-LVDS Buffer	LVPECL/LVDS/LVCMOS	LVDS	0 to 800	2.5	1.5ns (typ)	20ps	-40 to 85	N	QFN-40	4.75
CDCLVD1216	Low-Jitter, 2-Input Selectable 1:16 Universal-to-LVDS Buffer	LVPECL/LVDS/LVCMOS	LVDS	0 to 800	2.5	1.5ns (typ)	20ps	-40 to 85	N	QFN-48	5.70
CDCLVD2102	Low-Jitter, Dual 1:2 Universal-to-LVDS Buffer	LVPECL/LVDS/LVCMOS	LVDS	0 to 800	2.5	1.5ns (typ)	20ps (Within Bank)	-40 to 85	N	QFN-16	3.00
CDCLVD2104	Low-Jitter, Dual 1:4 Universal-to-LVDS Buffer	LVPECL/LVDS/LVCMOS	LVDS	0 to 800	2.5	1.5ns (typ)	20ps (Within Bank)	-40 to 85	N	QFN-28	4.00
CDCLVD2106	Low-Jitter, Dual 1:6 Universal-to-LVDS Buffer	LVPECL/LVDS/LVCMOS	LVDS	0 to 800	2.5	1.5ns (typ)	20ps (Within Bank)	-40 to 85	N	QFN-40	5.00
CDCLVD2108	Low-Jitter, Dual 1:8 Universal-to-LVDS Buffer	LVPECL/LVDS/LVCMOS	LVDS	0 to 800	2.5	1.5ns (typ)	20ps (Within Bank)	-40 to 85	N	QFN-48	6.00
CDCLVD1213	Low-Jitter, 1:4 Universal-to-LVDS Buffer with Selectable Output Divider	LVPECL/LVDS/CML	LVDS	0 to 800	2.5	1.5ns (typ)	20ps	-40 to 85	N	QFN-16	4.00
CDCP1803	1:3 LVPECL Clock Buffer with Programmable Divider	LVPECL/LVDS	LVPECL	0 to 800	3.3	320 to 600ps	30ps	-40 to 85	Y	QFN-24	3.15
CDCLVP215	Dual 1:5 High-Speed LVPECL Clock Buffer	LVPECL	LVPECL	DC to 3.5GHz	2.5/3.3	230 to 370ps	30ps	-40 to 85	N	LQFP-32	5.55
CDCLVP110	1:10 LVPECL Clock Buffer	LVPECL/HSTL	LVPECL	0 to 3.5GHz	2.5/3.3	230 to 370ps	30ps	-40 to 85	N	LQFP-32	5.50
CDCLVP111	1:10 LVPECL Clock Buffer with Selectable Input	LVPECL	LVPECL	DC to 3.5GHz	2.5/3.3	230 to 370ps	30ps	-40 to 85	N	LQFP-32/QFN-32	5.55
CDCLVD110A	Programmable 1:10 LVDS Clock Buffer	LVDS	LVDS	0 to 900	2.5	3ns	30ps (typ)	-40 to 85	N	TQFP-32	5.50
CDCL1810	1:10 LVDS-to-CML Clock Buffer	LVDS	CML	0 to 650	1.8	3ns	64ps	-40 to 85	N	QFN-48	6.45
SN65EL11	1:2 ECL/PECL Buffer	ECL/PECL	ECL/PECL	>2.5GHz	5	265ps (typ)	15	-40 to 85	N	SOIC-8/MSOP-8	1.35
SN65EL16	1:1 ECL/PECL Buffer	ECL/PECL	ECL/PECL	>2.5GHz	5	250ps (typ)	20	-40 to 85	N	SOIC-8/MSOP-8	1.35
SN65ELT20	1:1 TTL-to-PECL Buffer	TTL	PECL	400 (Typ)	5	1250ps (max)	—	-40 to 85	N	SOIC-8/MSOP-8	1.45
SN65ELT21	1:1 PECL-to-TTL Buffer	TTL	PECL	0 to 400	5	3000ps (typ)	—	-40 to 85	N	SOIC-8/MSOP-8	1.40
SN65ELT22	2:2 TTL-to-PECL Buffer	TTL	PECL	0 to 1GHz	5	1100ps (max)	90	-40 to 85	N	SOIC-8/MSOP-8	1.45
SN65ELT23	2:2 PECL-to-TTL Buffer	PECL	TTL	0 to 500	5	3500ps (typ)	—	-40 to 85	N	SOIC-8/MSOP-8	1.40
SN65EPT21	1:1 LVTTTL-to-LVPECL Buffer	LVTTTL	LVPECL	0 to 600	3.3	1900ps (max)	250	-40 to 85	N	SOIC-8/MSOP-8	1.80
SN65EPT22	2:2 LVTTTL-to-LVPECL Buffer	LVTTTL	LVPECL	0 to 4GHz	3.3	420ps (typ)	50	-40 to 85	N	SOIC-8/MSOP-8	1.80
SN65EPT23	2:2 LVPECL-to-LVTTTL Buffer	LVPECL	LVTTTL	>300	3.3	1900ps (max)	110	-40 to 85	N	SOIC-8/MSOP-8	1.80

*Suggested resale price in U.S. dollars in quantities of 1,000. See www.ti.com/hirel for HiRel options.

New devices are listed in bold red.

Clocks and Timing

➔ Clock Distribution (Fan-Out Clock Buffers, Zero-Delay Buffers)

Clock Distribution (continued)

Device	Description	Input Level	Output Level	Frequency (MHz)	V _{CC} (V)	Propagation Delay	Output Skew (max) (ps)	Char. Temp. (°C)	HiRel Avail.	Package(s)	Price*
Fan-Out Clock Buffers (Non-PLL)											
Differential-Ended											
SN65EPT21	1:1 LVTTTL-to-LVPECL Buffer	LVTTTL	LVPECL	0 to 600	3.3	1900ps (max)	250	-40 to 85	N	SOIC-8/MSOP-8	1.80
SN65EPT22	2:2 LVTTTL-to-LVPECL Buffer	LVTTTL	LVPECL	0 to 4GHz	3.3	420ps (typ)	50	-40 to 85	N	SOIC-8/MSOP-8	1.80
SN65EPT23	2:2 LVPECL-to-LVTTTL Buffer	LVPECL	LVTTTL	>300	3.3	1900ps (max)	110	-40 to 85	N	SOIC-8/MSOP-8	1.80
SN65LVEL11	1:2 ECL/PECL Buffer	ECL/PECL	ECL/PECL	0 to 1.5GHz	3.3	265ps (typ)	18	-40 to 85	N	SOIC-8/MSOP-8	1.45
SN65LVELT22	2:2 LVTTTL-to-LVPECL Buffer	LVTTTL	LVPECL	0 to 3.5GHz	3.3	450ps (typ)	50	-40 to 85	N	SOIC-8/MSOP-8	1.45
SN65LVELT23	2:2 LVPECL-to-LVTTTL Buffer	LVPECL	LVTTTL	>180	3.3	2200ps (max)	150	-40 to 85	N	SOIC-8/MSOP-8 SOIC-8/MSOP-8	2.30
SN65LVEP11	1:2 ECL/PECL Buffer	ECL/PECL	ECL/PECL	0 to 3GHz	2.5/3.3	240ps (typ)	15	-40 to 85	N	SOIC-8/MSOP-8	2.20
Single-Ended											
CDC3RL02	1:2 Square/Sine-to-Square Wave Buffer with LDO	SINE/SQUARE	SQUARE	10 to 52	1.8	12ns (typ)	500ps	-40 to 85	N	DSBGA-8	0.90
CDC3S04	1:4 Sine-to-Sine Wave Buffer with LDO	SINE	SINE	.01 to 52	1.8	3ns (max)	50ps	-30 to 85	N	DSBGA-20	1.80
CDCLVC1102	Low-Jitter, 1:2 LVCMOS Fan-Out Clock Buffer	LVC MOS	LVC MOS	0 to 250	2.5/3.3	0.8 to 2ns	50ps	-40 to 85	N	TSSOP-8	0.90
CDCLVC1103	Low-Jitter, 1:3 LVCMOS Fan-Out Clock Buffer	LVC MOS	LVC MOS	0 to 250	2.5/3.3	0.8 to 2ns	50ps	-40 to 85	N	TSSOP-8	1.05
CDCLVC1104	Low-Jitter, 1:4 LVCMOS Fan-Out Clock Buffer	LVC MOS	LVC MOS	0 to 250	2.5/3.3	0.8 to 2ns	50ps	-40 to 85	N	TSSOP-8	1.20
CDCLVC1106	Low-Jitter, 1:6 LVCMOS Fan-Out Clock Buffer	LVC MOS	LVC MOS	0 to 250	2.5/3.3	0.8 to 2ns	50ps	-40 to 85	N	TSSOP-14	1.50
CDCLVC1108	Low-Jitter, 1:8 LVCMOS Fan-Out Clock Buffer	LVC MOS	LVC MOS	0 to 250	2.5/3.3	0.8 to 2ns	50ps	-40 to 85	N	TSSOP-16	1.80
CDCLVC1110	Low-Jitter, 1:10 LVCMOS Fan-Out Clock Buffer	LVC MOS	LVC MOS	0 to 250	2.5/3.3	0.8 to 2ns	50ps	-40 to 85	N	TSSOP-20	2.25
CDCLVC1112	Low-Jitter, 1:12 LVCMOS Fan-Out Clock Buffer	LVC MOS	LVC MOS	0 to 250	2.5/3.3	0.8 to 2 ns	50ps	-40 to 85	N	TSSOP-24	2.60
CDC318A	1:18 LVTTTL Clock Buffer with I ² C Control	LVTTTL	LVTTTL	0 to 100	3.3	1.2 to 4.5ns	250ps	0 to 70	N	SSOP-48	2.10
CDC319	1:10 LVTTTL Clock Buffer with I ² C Control	LVTTTL	LVTTTL	0 to 140	3.3	1.2 to 3.6ns	250ps	0 to 70	N	SSOP-28	1.75
CDCV304	1:4 PCI-X Compliant LVTTTL Clock Buffer	LVTTTL	LVC MOS	0 to 200	2.5/3.3	1.8 to 3.0ns	100ps	-40 to 85	N	TSSOP-8	1.20
CDCVF310	1:10 LVTTTL Clock Buffer (2 Banks of 5 Outputs)	LVTTTL/ LVC MOS	LVTTTL/ LVC MOS	0 to 200	2.5/3.3	1.0 to 2.8ns (V _{DD} = 3. V), 1.3 to 4.0ns (V _{DD} = 2.5 V)	150ps at 3.3V, 230ps at 2.5V	-40 to 85	N	TSSOP-24	2.05
CDCVF2310	1:10 LVTTTL Clock Buffer (2 Banks of 5 Outputs) with 25Ω input resistors	LVTTTL/ LVC MOS	LVTTTL/ LVC MOS	0 to 170 (V _{DD} = 2.5V), 0 to 200 (V _{DD} = 3.3 V)	2.5/3.3	1.3 to 2.8ns (V _{DD} = 3.3 V), 1.5 to 3.5ns (V _{DD} = 2.5 V)	100ps at 3.3V, 170ps at 2.5V	-40 to 85	N	TSSOP-24	2.05
Mixed: Differential and Single-Ended											
CDCM1804	1:3 LVPECL + 1:1 LVCMOS Buffer with Dividers	LVPECL	LVPECL/ LVC MOS	800	3.3	600ps (LVPECL), 2.6ns (LVC MOS)	30ps (LVPECL), 1.6ns (LVC MOS)	-40 to 85	N	QFN-24	5.90
CDCM1802	1:1 LVCMOS + 1:1 LVPECL Buffer with Dividers	LVPECL	LVPECL/ LVC MOS	800	3.3	600ps (LVPECL), 2.6ns (LVC MOS)	1.6ns (typ)	-40 to 85	N	QFN-16	4.70
CDCE18005	3:5 LVPECL/LVDS/LVC MOS Buffer with Dividers	LVPECL/ LVDS/ LVC MOS	LVPECL/ LVDS/ LVC MOS	DC to 1.5GHz	3.3	4ns	75ps	-40 to 85	N	QFN-48	6.00

*Suggested resale price in U.S. dollars in quantities of 1,000.

New devices are listed in bold red.

Clocks and Timing

→ Clock Distribution (Fan-Out Clock Buffers, Zero-Delay Buffers)

Clock Distribution (continued)

Device	Description	Input Level	Output Level	Frequency (MHz)	V _{CC} (V)	Jitter (Peak-to-Peak [P-P] or Cycle-to-Cycle [C-C])	Phase Error	Char. Temp. (°C)	HiRel Avail.	Package(s)	Price*
Zero-Delay Buffers (PLL-Based)											
Differential-Ended											
CDCV850	1:10 Differential Clock Driver	SSTL_2/ Universal	SSTL_2	60 to 140	2.5	C-C: ±30ps (100 to 133MHz)	-80/150ps (133MHz)	-40 to 85	N	TSSOP-48	2.20
CDCV855	1:4 Differential Clock Driver	SSTL_2/LVTTL	SSTL_2	60 to 180	2.5	C-C: ±50ps (100 to 180MHz)	±100ps (100 to 180MHz)	-40 to 85	N	TSSOP-28	1.15
CDCV857	1:10 PLL Differential Clock Driver for DDR 200/266/333, SSC	SSTL_2/LVTTL	SSTL_2	60 to 200	2.5	C-C: ±75ps (100 to 200MHz)	-150/50ps (200MHz)	0 to 85	N	TSSOP-48	4.20
CDCV857A	1:10 PLL Differential Clock Driver for DDR 200/266/333, SSC	SSTL_2/LVTTL	SSTL_2	60 to 180	2.5	C-C: ±50ps (100 to 180MHz)	±100ps (100 to 180MHz)	0 to 85	N	TSSOP-48, µBGA-56	2.90
CDCV857B	1:10 PLL Differential Clock Driver for DDR 200/266/333, SSC	SSTL_2/LVTTL	SSTL_2	60 to 200	2.5	C-C: ±50ps (100 to 200MHz)	±50ps (min/max) (100 to 200MHz)	0 to 70	N	TSSOP-48, µBGA-56	3.65
CDCV857BI	1:10 PLL Differential Clock Driver for DDR 200/266/333, SSC	SSTL_2/LVTTL	SSTL_2	60 to 200	2.5	C-C: ±50ps (100 to 200MHz)	±50ps (min/max) (100 to 200MHz)	-40 to 85	N	TSSOP-48, µBGA-56	3.35
CDCVF857	1:10 PLL Differential Clock Driver for DDR 200/266/333/400, SSC	SSTL_2/LVTTL	SSTL_2	60 to 220	2.5	C-C: ±35ps (133 to 200MHz)	±50ps (min/max) (100 to 200MHz)	-40 to 85	N	TSSOP-48, QFN-48, µBGA-56	3.60
CDCU877	1:10 PLL Differential Clock Driver for DDR2 Applications, SSC	SSTL_18	SSTL_18	10 to 400	1.8	C-C: ±30ps (190 to 340MHz)	±50ps	-40 to 85	N	µBGA-52, QFN-40	3.05
CDCU877A	1:10 PLL Differential Clock Driver for DDR2 Applications, SSC	SSTL_18	SSTL_18	10 to 400	1.8	C-C: ±30ps (190 to 340MHz)	±50ps	-40 to 85	N	µBGA-52, QFN-40	3.05
CDCU877B	1:10 PLL Differential Clock Driver for DDR2 400/533, SSC	SSTL_18	SSTL_18	10 to 340	1.8	C-C: ±30ps (190 to 340MHz)	±50ps	-40 to 85	N	µBGA-52	3.05
CDCUA877	1:10 PLL Differential Clock Driver for DDR2 400~800, SSC, 8-mA Output	SSTL_18	SSTL_18	125 to 410	1.8	C-C: ±40ps (200 to 333MHz)	±50ps	-40 to 85	N	µBGA-52	3.35
CDCU2A877	1:10 PLL Differential Clock Driver for DDR2 400~800, SSC, 16-mA Output	SSTL_18	SSTL_18	125 to 410	1.8	C-C: ±40ps (160 to 410MHz)	±50ps	0 to 70	N	µBGA-52	3.05
Single-Ended											
CDCVF2505	1:5 PLL Clock Driver for SDR/PC133+, SSC	LVTTL	LVTTL	24 to 200	3.3	C-C: 170ps (typ) (66 to 200MHz)	±150ps (66 to 200MHz)	-40 to 85	Y	TSSOP-8, SOIC-8	0.95
CDCVF2509A	1:9 PLL Clock Driver for SDR/PC133+, SSC	LVTTL	LVTTL	50 to 175	3.3	C-C: 165ps (typ) (100 to 166MHz)	±125ps (66 to 166MHz)	0 to 85	N	TSSOP-24	3.90
CDCVF2510A	1:10 PLL Clock Driver for SDR/PC133+, SSC	LVTTL	LVTTL	50 to 175	3.3	C-C: 165ps (typ) (100 to 166MHz)	±125ps (66 to 166MHz)	0 to 85	N	TSSOP-24	2.60

*Suggested resale price in U.S. dollars in quantities of 1,000. See www.ti.com/hirel for HiRel options.

Clocks and Timing

➔ Clock Generation (Crystal Oscillator Replacements, Jitter Cleaners)

Clock Generator/Jitter Cleaner with Integrated Dual VCO

CDCE6200x

Get samples and datasheets at: www.ti.com/sc/device/CDCE62005

Key Features

- Fully integrated synthesizer – PLL, VCO, partially integrated loop filter
- Two universal (LVPECL/LVDS/LVCMOS inputs), one auxiliary/XTAL input
- Up to 5 fully configurable outputs up to 1.175GHz (LVPECL, LVDS or 2-LVCMOS)
- Integrated RMS jitter <500fs (10kHz-20MHz)
- On-chip EEPROM determines default state at power-up; fully programmable via SPI™ port

Applications

- Data converter and data aggregation clocking
- Wireless infrastructure
- Switches and routers
- Medical electronics
- Military and aerospace
- Industrial
- Clock generation and jitter cleaning

The CDCE6200x is a high-performance clock generator and distributor featuring low output jitter, a high degree of configurability via a SPI™ interface and programmable start-up modes determined by on-chip EEPROM. Specifically tailored for clocking data converters and high-speed digital signals, the CDCE6200x achieves jitter performance <1ps RMS jitter (10kHz to 20MHz). It incorporates a synthesizer block with partially integrated loop filter, a clock distribution block including programmable output formats and an input block featuring an innovative smart multiplexer. The clock distribution block includes up to five individually programmable outputs that can be configured to provide different combinations of output formats (LVPECL, LVDS, LVCMOS).

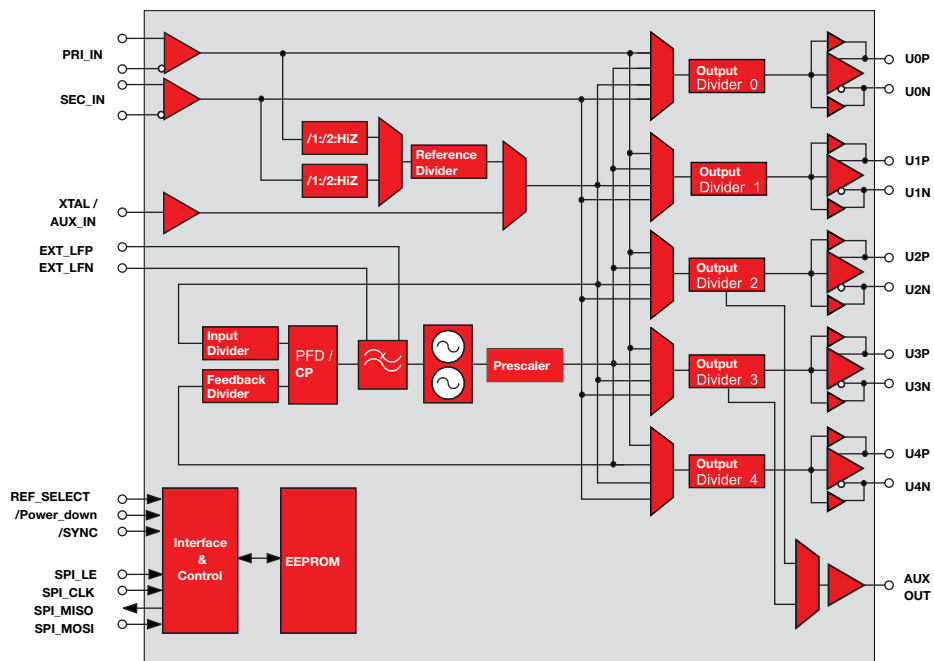

CDCE62005 functional block diagram

Clocks and Timing

→ Clock Generation (Crystal Oscillator Replacements, Jitter Cleaners)

Clock Oscillator Replacements

CDCE9xx

Get samples and datasheets at: www.ti.com/sc/device/CDCE949

Key Features

- Fully programmable clock synthesizer with 3.3V/2.5V/1.8V I/Os
- Up to 4 internal fractional PLLs enable 0-PPM clock generation
- Up to 9 low-jitter, low-skew LVCMOS outputs up to 230MHz
- Flexible input clocking concept
 - External crystal: 8MHz to 32MHz
 - On-chip VCXO: pull-range ± 150 ppm
 - Single-ended LVCMOS up to 160MHz

Applications

- D-TV, HD-TV, STB, IP-STB, DVD-players, DVD recorders, printers
- General-purpose frequency synthesizing
- DSP, DaVinci™ and OMAP™ attach audio and video clocking

The CDCE(L)9xx are modular PLL-based low-cost, high-performance, programmable clock generators/synthesizers. They generate up to 9 output clocks from a single input frequency. Each output can be programmed in-system for any clock frequency up to 230MHz, using up to four independent configurable PLLs.

The CDCE9xx have separate output supply pins for V_{DDOUT} 2.5V and 3.3V, whereas the CDCEL9xx supports 1.8V. The input accepts an external crystal or LVCMOS clock signal. If an external crystal is used, an on-chip load capacitor is adequate for most applications. The value of the load capacitor is programmable from 0 to 20pF. Additionally, an on-chip VCXO is selectable, allowing synchronization of the output frequency to an external control (PWM) signal.

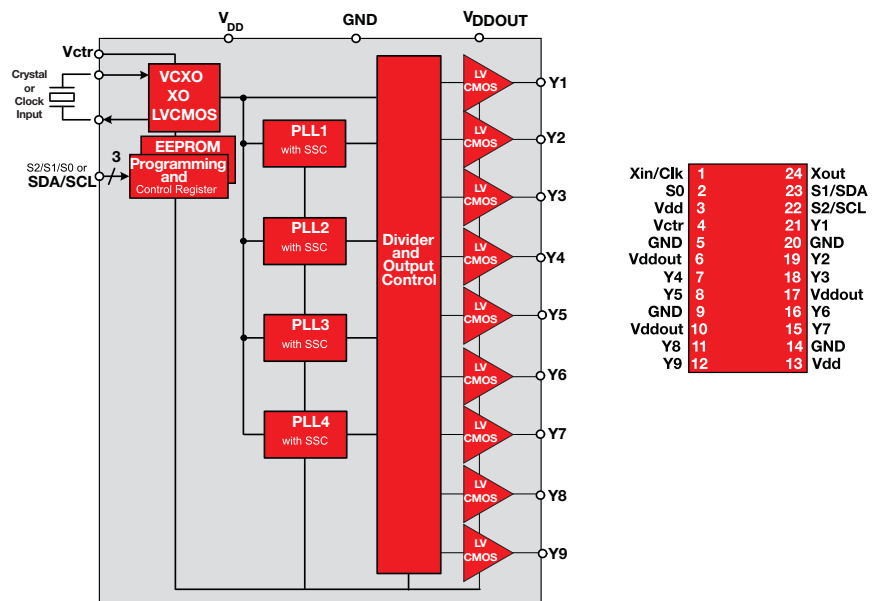

CDCE949 functional block diagram

Clocks and Timing

➔ Clock Generation (Crystal Oscillator Replacements, Jitter Cleaners)

Clock Oscillator Replacements

CDCM6100x

Get samples and datasheets at: www.ti.com/sc/device/CDCM61004

Key Features

- Input frequency range: 21.875MHz to 28.47MHz
- Output frequency range: 43.75MHz to 683.264MHz
- Device settings managed through a control pin structure (prescaler and feedback divider, output divider, output type)
- Supports common frequencies utilized in datacom, telecom and consumer applications
- Low-jitter outputs <1ps RMS (10kHz to 20MHz), ~25ps pk-pk

Applications

- Precision clock generator for:
 - Datacom/telecom/networking
 - Wireless infrastructure
 - High-frequency, high-cost XO replacement

The CDCM6100x is a highly versatile, low-jitter frequency synthesizer that can generate up to four low-jitter clock outputs (selectable between LVPECL, LVDS or LVCMOS outputs) from a low-frequency crystal input for a variety of wireline and data communication applications. The CDCM6100x features an onboard PLL that can be easily configured solely through control pins. The overall output random jitter performance is <1ps RMS (10kHz-20MHz), making this device a perfect choice for use in demanding applications such as SNET, Ethernet, Fibre Channel and SAN.

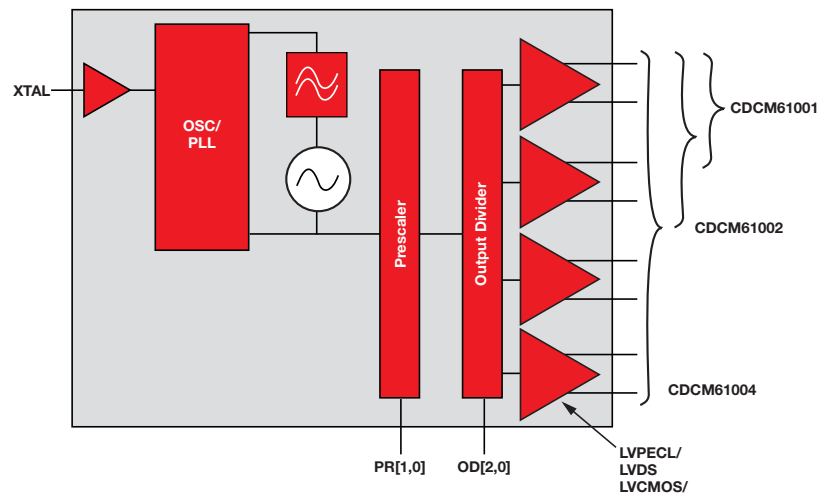

CDCM6100x functional block diagram

Clock Generation

Device	Description	Input Level	Output Level	Frequency (MHz)	V _{CC} (V)	Jitter (Peak-to-Peak [P-P] or Cycle-to-Cycle [C-C])	Phase Error	Output Skew (max) (ps)	Char. Temp. (°C)	HiRel Avail.	Package	Price*
Crystal Oscillator (XO) Replacements – Differential-Ended												
CDCE421A	Flexible Low-Jitter Clock Generator, 10MHz to 1.1GHz	Crystal/LVCMOS	LVDS/LVPECL	11 to 1100	3.3	—	<1ps rms	—	-40 to 85	N	Die/QFN-24	7.10
CDC421A100	Low-Jitter 100MHz Clock Generator for PCI Express	Crystal/LVCMOS	LVPECL	100	3.3	—	<1ps rms	—	-40 to 85	N	QFN-24	7.00
CDC421A106	Low-Jitter 106.25MHz Clock Generator for Fibre Channel	Crystal/LVCMOS	LVPECL	106.25	3.3	—	<1ps rms	—	-40 to 85	N	QFN-24	7.00
CDC421A125	Low-Jitter 125MHz Clock Generator for Ethernet	Crystal/LVCMOS	LVPECL	125	3.3	—	<1ps rms	—	-40 to 85	N	QFN-24	7.00
CDC421A156	Low-Jitter 156.25MHz Clock Generator for 10G Ethernet	Crystal/LVCMOS	LVPECL	156.25	3.3	—	<1ps rms	—	-40 to 85	N	QFN-24	7.00
CDC421A212	Low-Jitter 212.5MHz Clock Generator for Fibre Channel	Crystal/LVCMOS	LVPECL	212.5	3.3	—	<1ps rms	—	-40 to 85	N	QFN-24	7.00
CDC421A250	Low-Jitter 250MHz Clock Generator for PCI Express	Crystal/LVCMOS	LVPECL	250	3.3	—	<1ps rms	—	-40 to 85	N	QFN-24	7.00
CDC421A312	Low-Jitter 312.5MHz Clock Generator for 10G Ethernet	Crystal/LVCMOS	LVPECL	312.5	3.3	—	<1ps rms	—	-40 to 85	N	QFN-24	7.00

*Suggested resale price in U.S. dollars in quantities of 1,000.

Clocks and Timing

→ Clock Generation (Crystal Oscillator Replacements, Jitter Cleaners)

Clock Generation (continued)

Device	Description	Input Level	Output Level	Frequency (MHz)	V _{CC} (V)	Jitter (Peak-to-Peak [P-P] or Cycle-to-Cycle [C-C])	Phase Error	Output Skew (max) (ps)	Char. Temp. (°C)	HiRel Avail.	Package(s)	Price*
Crystal Oscillator (XO) Replacements - Single Ended												
CDCE913	1.8V Programmable 1-PLL, 3 Output Clock Synthesizer with 2.5/3.3V Outputs	Crystal/LVCMOS	2.5/3.3V LVCMOS	0 to 230	1.8/3.3	60ps (typ)	—	150	-40 to 85	N	TSSOP-14	1.60
CDCEL913	1.8V Programmable 1-PLL, 3 Output Clock Synthesizer with 1.8V Outputs	Crystal/LVCMOS	1.8V LVCMOS	0 to 230	1.8/3.3	60ps (typ)	—	150	-40 to 85	Y	TSSOP-14	1.60
CDCE925	1.8V Programmable 2-PLL, 5 Output Clock Synthesizer with 2.5/3.3V Outputs	Crystal/LVCMOS	2.5/3.3V LVCMOS	0 to 230	1.8/3.3	60ps (typ)	—	150	-40 to 85	N	TSSOP-16	1.95
CDCEL925	1.8V Programmable 2-PLL, 5 Output Clock Synthesizer with 1.8V Outputs	Crystal/LVCMOS	1.8V LVCMOS	0 to 230	1.8/3.3	60ps (typ)	—	150	-40 to 85	N	TSSOP-16	1.80
CDCE937	1.8V Programmable 3-PLL, 7 Output Clock Synthesizer with 2.5/3.3V Outputs	Crystal/LVCMOS	2.5/3.3V LVCMOS	0 to 230	1.8/3.3	60ps (typ)	—	150	-40 to 85	Y	TSSOP-20	2.15
CDCEL937	1.8V Programmable 3-PLL, 7 Output Clock Synthesizer with 1.8V Outputs	Crystal/LVCMOS	1.8V LVCMOS	0 to 230	1.8/3.3	60ps (typ)	—	150	-40 to 85	Y	TSSOP-20	2.15
CDCE949	1.8V Programmable 4-PLL, 9 Output Clock Synthesizer with 2.5/3.3V Outputs	Crystal/LVCMOS	2.5/3.3V LVCMOS	0 to 230	1.8/3.3	60ps (typ)	—	150	-40 to 85	Y	TSSOP-24	2.35
CDCEL949	1.8V Programmable 4-PLL, 9 Output Clock Synthesizer with 1.8V Outputs	Crystal/LVCMOS	1.8V LVCMOS	0 to 230	1.8/3.3	60ps (typ)	—	150	-40 to 85	N	TSSOP-24	2.35
CDCE706	3.3V Programmable 3-PLL, 6 Output Clock Synthesizer	Crystal/LVCMOS/Differential	2.5/3.3V LVCMOS	0 to 300	3.3	60ps (typ)	—	200	-40 to 85	N	TSSOP-20	3.85
CDCE906	3.3V Programmable 3-PLL, 6 Output Clock Synthesizer	Crystal/LVCMOS/Differential	2.5/3.3V LVCMOS	0 to 167	3.3	60ps (typ)	—	200	0 to 70	N	TSSOP-20	2.20
CDCS501	1:1 Spread Spectrum Clock Generator	LVCMOS	3.3V LVCMOS	40 to 108	3.3	110ps (typ)	—	—	-40 to 85	N	TSSOP-8	0.45
CDCS502	1:1 Clock Generator with Optional SSC	Crystal	3.3V LVCMOS	8 to 108	3.3	100ps (typ)	—	—	-40 to 85	N	TSSOP-8	0.95
CDCS503	1:1 Clock Buffer/Multiplier with Optional SSC	LVCMOS	3.3V LVCMOS	8 to 108	3.3	110ps (typ)	—	—	-40 to 85	N	TSSOP-8	0.50
Mixed: Differential and Single-Ended												
CDCM61001	1:1 Low-Jitter, Integrated VCO Clock Generator	Crystal/LVCMOS	LVPECL/LVDS/2-LVCMOS	43.75 to 683.28; LVCMOS up to 250MHz	3.3	<1ps rms	—	—	-40 to 85	N	QFN-32	4.20
CDCM61002	1:2 Low-Jitter, Integrated VCO Clock Generator	Crystal/LVCMOS	LVPECL/LVDS/2-LVCMOS	43.75 to 683.28; LVCMOS up to 250MHz	3.3	<1ps rms	—	50	-40 to 85	N	QFN-32	5.00
CDCM61004	1:4 Low-Jitter, Integrated VCO Clock Generator	Crystal/LVCMOS	LVPECL/LVDS/2-LVCMOS	43.75 to 683.28; LVCMOS up to 250MHz	3.3	<1ps rms	—	60	-40 to 85	N	QFN-32	6.50
CDCE62002	2:2 Low-Jitter, Integrated VCO Clock Generator	Crystal/LVCMOS/Differential	LVPECL/LVDS/2-LVCMOS	4.25 to 1175	3.3	<1ps rms	—	75	-40 to 85	N	QFN-32	6.60
CDCE62005	3:5 Low-Jitter, Integrated VCO Clock Generator	Crystal/LVCMOS/Differential	LVPECL/LVDS/2-LVCMOS	4.25 to 1175	3.3	<1ps rms	—	75	-40 to 85	N	QFN-48	7.50
Jitter Cleaners – Internal VCO												
CDCE62002	2:2 Low-Jitter, Integrated VCO Clock Generator	Crystal/LVCMOS/Differential	LVPECL/LVDS/2-LVCMOS	4.25 to 1175	3.3	<1ps rms	—	75	-40 to 85	N	QFN-32	6.60
CDCE62005	3:5 Low-Jitter, Integrated VCO Clock Generator	Crystal/LVCMOS/Differential	LVPECL/LVDS/2-LVCMOS	4.25 to 1175	3.3	<1ps rms	—	75	-40 to 85	N	QFN-48	7.50
CDCL6010	1:10 LVDS-to-CML Jitter Cleaner and Distributor	LVDS	CML	15 to 1250	1.8	<1ps rms	—	64	-40 to 85	N	QFN-48	8.05
Jitter Cleaners – External VCXO												
CDCM7005	2:5 Ultra-Low-Jitter Clock Synchronizer and Jitter Cleaner	LVCMOS/LVPECL	LVCMOS/LVPECL	0 to 1500	3.3	<1ps rms	-200/+100ps	50	-40 to 85	Y	BGA-64/QFN-48	9.50
CDCE72010	2:10 Ultra-Low-Jitter Clock Synchronizer and Jitter Cleaner	LVPECL/LVDS/LVCMOS	LVPECL/LVDS/LVCMOS	0 to 1500	3.3	<1ps rms	—	50	-40 to 85	N	QFN-64	10.95

*Suggested resale price in U.S. dollars in quantities of 1,000. See www.ti.com/hirel for HiRel options.

→ Communications – LVDS/LVPECL/CML Repeaters, Translators and Crosspoints

8x8 4.25Gbps Crosspoint Switch

SN65LVCP408

Get samples and datasheets at: www.ti.com/sc/device/SN65LVCP408

Key Features

- Up to 4.25Gbps operation
- Non-blocking architecture allows each output to be connected to any input
- 30ps of deterministic jitter
- Selectable transmit pre-emphasis per lane
- Selectable receive equalization
- Inputs electrically compatible with CML signal levels
- Ability to 3-state outputs

Applications

- High-speed signal switching and signal conditioning
- High-speed data buffering
- XAUI 802.3ae protocol backplane redundancy
- High-speed network routing in wireless base stations
- Passing 3G SDI pathological data pattern for video

The SN65LVCP408 is an 8x8 non-blocking crosspoint switch in a flow-through pin-out, allowing for ease in PCB layout. VML signaling is used to achieve a high-speed data throughput while using low power. Each of the output drivers includes a 8:1 multiplexer to allow any input to be routed to any output. Internal signal paths are fully differential to achieve high signaling speeds while maintaining low signal skews. The SN65LVCP408 incorporates 100Ω termination resistors for those applications where board space is a premium along with built-in transmit pre-emphasis and receive equalization for superior signal integrity performance.

The SN65LVCP408 is characterized for operation from –40°C to +85°C.

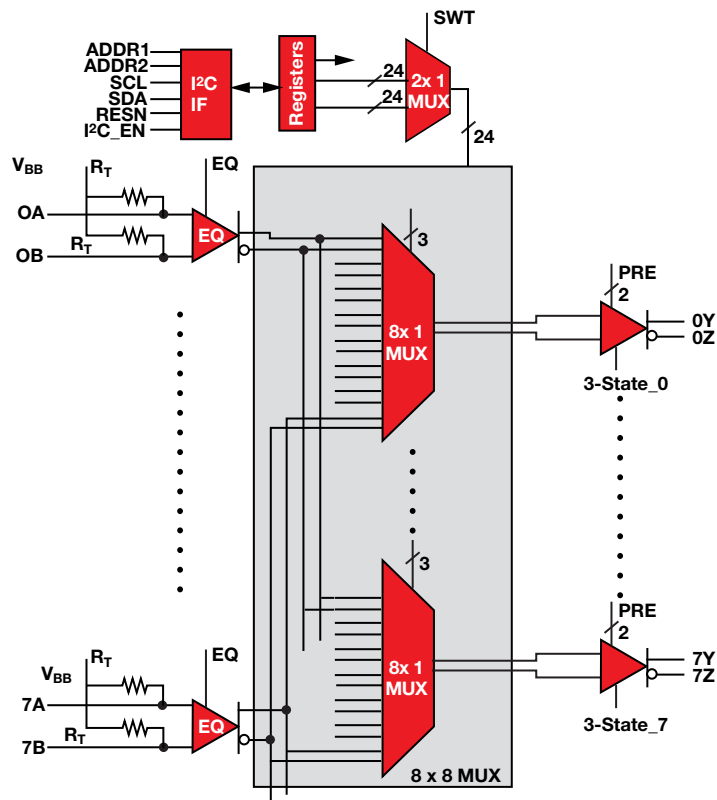

A. V_{BB} : Receiver input internal biasing
B. R_T : Internal 50-Ω receiver termination (100-Ω differential)

SN65LVCP408 functional block diagram

 **Communications – LVDS/LVPECL/CML Repeaters, Translators and Crosspoints**
LVDS/LVPECL/CML Repeaters, Translators and Crosspoints

Device	Description	No. of Tx	No. of Rx	Input Signal	Output Signal	Signaling Rate (Mbps)	Jitter Max (ps)	Part-to-Part Skew Max	Tx tpd Typ. (ns)	Rx tpd Typ. (ns)	ICC Max (mA)	ESD HBM (kV)	HiRel Avail.	Package(s)	Price*
Crosspoint Switch Family															
SN65LVCP22	2x2 Crosspoint Switch: LVDS Outputs	2	2	LVPECL, LVDS, CML	LVDS	1000	105	100	0.65	0.65	85	5	N	SOIC-16, TSSOP-16	2.70
SN65LVCP23	2x2 Crosspoint Switch: LVPECL Outputs	2	2	LVPECL, LVDS, CML	LVPECL	1300	100	100	0.65	0.65	65	5	N	SOIC-16, TSSOP-16	5.20
SN65LVCP40	Dual 1:2 Mux with Equalizer and Pre-Emphasis	6	6	LVPECL, LVDS, CML	CML	4000	30	500	1	1	254	4	N	QFN-48	17.40
SN65LVCP402	2x2 Crosspoint Switch with Rx-Eq	2	2	CML	VML	4250	30	300	0.5	0.5	115	4	N	2QFN-24	7.15
SN65LVCP404	4x4 Crosspoint Switch with Rx-Eq	4	4	CML	VML	4250	30	300	0.5	0.5	220	4	N	QFN-48	10.55
SN65LVCP408	8X8 Crosspoint Switch with Rx-Eq	8	8	CML	VML	4250	30	300	0.5	0.5	350	3	N	HTQFP-64	15.90
SN65LVDS122	2x2 Crosspoint Switch: LVDS Output	2	2	LVPECL, LVDS, CML	LVDS	1500	65	150	0.9	0.9	100	4	N	1SOIC-16 TSSOP-16	4.75
SN65LVDS250	4x4 Crosspoint Switch: LVDS Output	4	4	LVPECL, LVDS, CML	LVDS	2000	50	150	0.9	0.9	145	3	N	TSSOP-38	8.30
Repeaters/Translators															
SN65CML100	LVDS/LVPECL/CML-to-CML Repeater/Translator	1	1	LVPECL, LVDS, CML	CML	1500	70	100	0.8	—	12	5	N	SOIC-8, VSSOP-8	2.55
SN65LVCP418	8-Channel Repeater with Rx-Eq	8	8	CML	VML	4250	30	300	0.5	0.5	350	3	N	HTQFP-64	15.90
SN65LVDS100	LVDS/LVPECL/CML to LVDS Repeater/Translator	1	1	LVPECL, LVDS, CML	LVDS	2000	65	100	0.8	—	30	5	N	SOIC-8, VSSOP-8	2.55
SN65LVDS101	LVDS/LVPECL/CML-to-LVPECL Repeater/Translator	1	1	LVPECL, LVDS, CML	LVPECL	2000	65	100	0.9	—	90	5	N	SOIC-8, VSSOP-8	2.55
SN65LVDS16/17	2.5V/3.3V Oscillator Gain Stage/Buffer (Single Ended Diff Inputs)	1	1	LVPECL	LVDS	2000	10	130	0.63	—	48	2	N	QFN-8	2.55
SN65LVDS18/19	2.5V/3.3V Oscillator Gain Stage/Buffer (Single Ended Diff Inputs)	1	1	LVPECL	LVDS	1000	10	130	0.63	—	36	2	N	QFN-8	1.95
SN65LVDS20	2.5V/3.3V LVDS Repeater with Enable	1	1	LVPECL	LVDS	4000	45	130	0.63	—	45	3	N	QFN-8	3.30
SN65LVP16/17	2.5V/3.3V Oscillator Gain Stage/Buffer (Single Ended Diff Inputs)	1	—	LVPECL	LVPECL	2000	10	130	0.63	—	30	2	N	QFN-8	2.55
SN65LVP18/19	2.5V/3.3V Oscillator Gain Stage/Buffer (Single Ended Diff Inputs)	1	—	LVPECL	LVPECL	1000	10	130	0.63	—	20	2	N	QFN-8	1.95
SN65LVP20	2.5V/3.3V LVPECL	1	1	LVPECL	LVPECL	4000	10	130	0.63	—	45	3	N	QFN-8	4.40

*Suggested resale price in U.S. dollars in quantities of 1,000.

LVDS

Device	Description	No. of Tx	No. of Rx	Input Signal	Output Signal	Signaling Rate (Mbps)	Part-to-Part Skew Max (ps)	Tx tpd Typ. (ns)	Rx tpd Typ. (ns)	ICC Max (mA)	ESD HBM (kV)	Supply Voltage (V)	HiRel Avail.	Package(s)	Price*
Single Family															
SN65LVDS1	Driver	1	—	LVTTTL	LVDS	630	—	1.7	—	8	15	3.3	N	SOIC-8, SOP-5	0.47
SN65LVDS2	Receiver	—	1	LVDS	LVTTTL	400	—	1.7	2.6	7	15	3.3	N	SOIC-8, SOP-5	0.47
SN65LVDS179	Full-Duplex Transceiver, No Enables	1	1	LVDS, LVTTTL	LVTTTL, LVDS	400Tx/150Rx	—	1.7	3.7	12	12	3.3	Y	SOIC-8, VSSOP-8	1.35
SN65LVDS180	Full-Duplex Transceiver, with Enables	1	1	LVDS, LVTTTL	LVTTTL, LVDS	400Tx/150Rx	—	1.7	3.7	12	12	3.3	Y	SOIC-14, TSSOP-14	1.35
Dual Family															
SN65LVDS9638	Driver	2	—	LVTTTL	LVDS	400	800	1.7	—	13	8	3.3	N	HTSSOP-8, SOIC-8, VSSOP-8	1.15
SN65LVDS9637	Receiver	—	2	LVDS	LVTTTL	400Tx/150Rx	1000	—	2.1	10	8	3.3	N	HTSSOP-8, SOIC-8, VSSOP-8	1.15
SN65LVDS049	Transceiver, Driver and Receiver Enable	2	2	LVDS, LVTTTL	LVTTTL, LVDS	400	100	1.3	1.9	35	10	3.3	N	TSSOP-16	1.00
SN65LVDS050	Transceiver, Driver and Receiver Enable	2	2	LVDS, LVTTTL	LVDS, LVTTTL	400Tx/150Rx	—	1.7	3.7	20	12	3.3	N	SOIC-16, TSSOP-16	2.00
SN65LVDS051	Transceiver, Driver Enable Only	2	2	LVDS, LVTTTL	LVDS, LVTTTL	400Tx/150Rx	—	1.7	3.7	20	12	3.3	Y	SOIC-16, TSSOP-16	2.00
SN65LVDS1050	Transceiver with 2.7V Supply	2	2	LVDS, LVTTTL	LVTTTL, LVDS	400Tx/150Rx	—	1.7	3.7	20	12	2.7	N	TSSOP-16	2.00
SN65LVDS22	Multiplexed LVDS Repeater	2	2	LVDS	LVDS	250	—	4	4	20	12	3.3	N	SOIC-16, TSSOP-16	2.80
Quad Family															
SN65LVDS047	Driver with Flow-Through Pinout	4	—	LVTTTL	LVDS	400	1000	1.8	—	26	8	3.3	N	SOIC-16, TSSOP-16	1.30
SN65LVDS31	Driver, AM26LS31 Footprint	4	—	LVTTTL	LVDS	400	800	1.7	—	35	8	3.3	Y	SOIC-16, TSSOP-16, SOP-16	1.50
SN65LVDS3487	Driver, MC34987 Footprint	4	—	LVTTTL	LVDS	400	800	1.7	—	35	8	3.3	N	SOIC-16	1.50
SN65LVDS391	Driver with Flow-Through Pinout	4	—	LVTTTL	LVDS	630	1500	1.7	—	26	15	3.3	N	SOIC-16, TSSOP-16	1.50
SN65LVDS048A	Receiver with Flow-Through Pinout	—	4	LVDS	LVTTTL	400	1000	—	2.4	15	10	3.3	N	SOIC-16, TSSOP-16	1.30
SN65LVDS32	Receiver, AM26LS32 Footprint	—	4	LVDS	LVTTTL	400Tx/150Rx	1000	—	2.1	18	8	3.3	Y	SOIC-16, TSSOP-16 SOP-16	1.50
SN65LVDS3486	Receiver, MC3486 Footprint	—	4	LVDS	LVTTTL	400Tx/150Rx	1000	—	2.1	18	8	3.3	N	SOIC-16	1.50
SN65LVDS390	Receiver with Flow-Through Pinout	—	4	LVDS	LVTTTL	630	1000	—	2.5	18	15	3.3	N	SOIC-16, TSSOP-16	1.50
SN65LVDS348	High-Speed Receiver with Flow-Through Pinout	—	4	CMOS, ECL, LVCMOS, LVDS, LVECL, LVPECL, PECL	LVTTTL	560	1000	4	—	20	15	3.3	N	SOIC-16, TSSOP-16	1.65

*Suggested resale price in U.S. dollars in quantities of 1,000. See www.ti.com/hirel for HiRel options.

LVDS

Device	Description	No. of Tx	No. of Rx	Input Signal	Output Signal	Signaling Rate (Mbps)	Part-to-Part Skew Max (ps)	Tx tpd Typ. (ns)	Rx tpd Typ. (ns)	ICC Max (mA)	ESD HBM (kV)	Supply Voltage (V)	HiRel Avail.	Package	Price*
8-Channel Family															
SN65LVDS389	Driver	8	—	LVTTTL	LVDS	630	1500	1.7	—	70	15	3.3	N	TSSOP-38	2.90
SN65LVDS388A1	Receiver	—	8	LVDS	LVTTTL	630	1000	—	2.5	40	15	3.3	N	TSSOP-38	2.90
16-Channel Family															
SN65LVDS387	Driver	16	—	LVTTTL	LVDS	630	1500	1.7	—	95	15	3.3	N	TSSOP-64	5.55
SN65LVDS386	Receiver	—	16	LVDS	LVTTTL	630	1000	—	2.5	70	15	3.3	N	TSSOP-64	5.55

MLVDS

Device	No. of Tx	No. of Rx	Rx Type	Half/ Full Duplex	Input Signal	Output Signal	Signaling Rate (Mbps)	Part-to-Part Skew Max (ps)	Tx tpd Typ. (ns)	Rx tpd Typ. (ns)	ICC Max (mA)	ESD HBM (kV)	TIA/ EIA-899 Standard Compliance	HiRel Avail.	Package(s)	Price*
SN65MLVD2	—	1	1	—	M-LVDS	LVTTTL	200	1000	—	—	25	9	Yes	N	SON-8	1.95
SN65MLVD3	—	1	2	—	M-LVDS	LVTTTL	200	1000	—	—	25	9	Yes	N	SON-8	1.95
SN65MLVD200A	1	1	1	Half	LVTTTL, M-LVDS	LVTTTL, M-LVDS	100	1000	2.5	3.6	24	8	Yes	N	SOIC-8	1.55
SN65MLVD201	1	1	1	Half	LVTTTL, M-LVDS	LVTTTL, M-LVDS	200	1000	1.5	4	24	8	Yes	N	SOIC-8	1.85
SN65MLVD202A	1	1	1	Full	LVTTTL, M-LVDS	LVTTTL, M-LVDS	100	1000	2.5	3.6	24	8	Yes	N	SOIC-14	1.55
SN65MLVD203	1	1	1	Full	LVTTTL, M-LVDS	LVTTTL, M-LVDS	200	1000	1.5	4	24	8	Yes	N	SOIC-14	1.85
SN65MLVD204A	1	1	2	Half	LVTTTL, M-LVDS	LVTTTL, M-LVDS	100	1000	2.5	3.6	24	8	Yes	N	SOIC-8	1.55
SN65MLVD205A	1	1	2	Full	LVTTTL, M-LVDS	LVTTTL, M-LVDS	100	1000	2.5	3.6	24	8	Yes	N	SOIC-14	1.55
SN65MLVD206	1	1	2	Half	LVTTTL, M-LVDS	LVTTTL, M-LVDS	200	1000	1.5	4	24	8	Yes	N	SOIC-8	1.85
SN65MLVD207	1	1	2	Full	LVTTTL, M-LVDS	LVTTTL, M-LVDS	200	1000	1.5	4	24	8	Yes	N	SOIC-14	1.85
SN65MLVD047	4	0	—	—	LVTTTL	M-LVDS	200	1000	1.5	—	60	12	Yes	N	SOIC-16, TSSOP-16	1.45
SN65MLVD048	0	4	1, 2	—	M-LVDS	LVTTTL	250	1000	—	6	25	8	Yes	N	VQFN-48	3
SN65MLVD128	8	1	—	—	LVTTTL	M-LVDS	200	800	1.5	1.5	140	8	Yes	N	TSSOP-48	3.8
SN65MLVD129	8	2	—	—	LVTTTL	M-LVDS	200	800	1.5	1.5	140	8	Yes	N	TSSOP-48	3.8
SN65MLVD040	4	4	1, 2	Half	LVTTTL, M-LVDS	LVTTTL, M-LVDS	250	600	2.4	6	90	8	Yes	N	VQFN-48	3.6
SN65MLVD080	8	8	1	Half	LVTTTL, LVDS	LVTTTL, M-LVDS	250	1000	2.4	6	180	8	Yes	N	TSSOP-64	4.75
SN65MLVD082	8	8	2	Half	LVTTTL, LVDS	LVTTTL, M-LVDS	250	1000	2.4	6	180	8	Yes	N	TSSOP-64	4.75
SN65LVDM179	1	1	—	Full	LVTTTL, LVDM	LVTTTL, LVDM	500	1000	1.7	3.7	15	12	—	N	SOIC-8, VSSOP-8	1.7
SN65LVDM0502	2	2	—	Full	LVTTTL, LVDM	LVTTTL, LVDM	500	1000	1.7	3.7	27	12	—	Y	SOIC-16, TSSOP-16	2.2
SN65LVDM22	2	2	—	—	LVDM	LVDM	250	—	4	4	27	12	—	N	SOIC-16, TSSOP-16	2.5
SN65LVDM31	4	0	—	—	LVC MOS	LVDM	150	1000	2.3	—	40	12	—	N	SOIC-16	1.55
SN65LVDM1676	16	16	—	Half	LVTTTL, LVDM	LVTTTL, LVDM	630	1000	2.5	3	175	15	—	N	TSSOP-64	7.75

*Suggested resale price in U.S. dollars in quantities of 1,000. See www.ti.com/hirel for HiRel options.

→ Communications – SERDES

Dual-Channel 0.47Gbps to 6.25Gbps Multi-Rate Transceiver TLK6002

Get samples and datasheets at: www.ti.com/sc/device/TLK6002

Key Features

- Dual-channel 470Mbps to 6.25Gbps continuous/multi-rate transceiver
- Supports all CPRI and OBSAI data rates
- Integrated latency measurement function, accuracy of ± 814 ps
- CPRI/OBSAI automated rate sense (ARS) function
- Serial-side three-tap transmit de-emphasis and receive adaptive equalization to allow extended backplane reach
- Programmable output swing on serial output
- Interface to backplane, copper cables or optical modules
- Hot plug protection
- JTAG; IEEE 1149.1/1149.6 test interface

Applications

- WI infrastructure – CPRI and OBSAI links
- Non-standard links
- High-speed point-to-point transmission systems
- Point-to-point cable links

The TLK6002 is a member of a portfolio of multi-gigabit transceivers, intended for use in ultra-high-speed bi-directional point-to-point data transmission systems. It is specifically intended for base station RRH (Remote Radio Head) applications, but may also be used in other high speed applications. The TLK6002 supports a serial interface speed of 0.470Gbps to 6.25Gbps. Rate support includes all CPRI and OBSAI rates (0.6144/0.768/1.2288/1.536/2.4576/3.072/4.9152/6.144Gbps) using a single fixed-reference clock frequency (either 122.88MHz or 153.6MHz).

The TLK6002 20-bit parallel interface operates in 1.5V or 1.8V HSTL single-ended format. The 20-bit interface allows low-speed signals on the parallel side, therefore enabling the use of low-cost FPGAs in the system design.

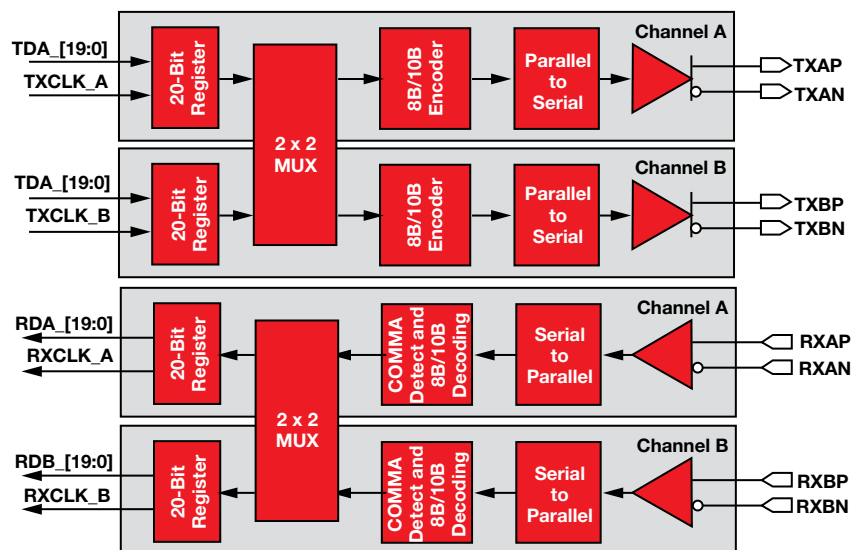

TLK6002 functional block diagram

SERDES (Serial Gigabit Transceivers)

Device	Description	Data Rate	Serial I/F1	Parallel I/F	Power	Special Features	HiRel Avail.	Price*
TLK1501	Single-Ch. 16:1 SERDES	0.6 to 1.5Gbps	1-CML	16-LVTTL	200mW	Built-In Testability	N	8.40
TLK2501	Single-Ch. 16:1 SERDES	1.6 to 2.5Gbps	1-CML	16-LVTTL	300mW	Built-In Testability	N	12.60
TLK2701	Single-Ch. 16:1 SERDES	1.6 to 2.5Gbps	1-CML	16-LVTTL	300mW	Built-In Testability and K Character Control	N	12.60
TLK2711	Single-Ch. 16:1 SERDES	1.6 to 2.5Gbps	1-VML	16-LVTTL	350mW	MicroStar Junior™ BGA Packaging	Y	10.50
TLK3101	Single-Ch. 16:1 SERDES	2.5 to 3.125Gbps	1-VML	16-LVTTL	350mW	Built-In Testability	N	16.85
TLK2521	Single-Ch. 18:1 SERDES	1.0 to 2.5Gbps	1-VML	18-LVTTL	<550mW	Low Power and Built-In Equalization	N	12.60
TLK1521	Single-Ch. 18:1 SERDES	0.6 to 1.3Gbps	1-VML	18-LVTTL	<350mW	Low Power and Built-In Equalization	N	10.50
TLK4120	Four-Ch. 18:1 SERDES	0.5 to 1.3Gbps	4-VML	18-LVTTL	<350mW	Four-Channel Version of TLK1521	N	24.00
TLK4250	Four-Ch. 18:1 SERDES	1.0 to 2.5Gbps	4-VML	18-LVTTL	<550mW	Four-Channel Version of TLK2521	N	32.00
TLK4015	Four-Ch. of 16:1 Xcvr	0.6 to 1.5Gbps/Ch.	4x-CML	16-LVTTL/Ch.	1W	Four-Channel Version of TLK1501	N	29.40
TLK1211	Single-Ch. 10:1 Gigabit Ethernet	0.6 to 1.3Gbps	1-LVPECL	10-LVTTL	200mW	Fast Relock for PON	N	Web
TLK2541	Single-Ch. 20:1 Txcr	1.0 to 2.6Gbps	1-LVPECL	20-LVTTL	625mW	Supports Independent 1 and 2.5Gbps Tx/Rx EPON OLT Channels	N	Web
TLK1201AI	Single-Ch. 10:1 Gigabit Ethernet Xcvr	0.6 to 1.3Gbps	1-LVPECL	10-LVTTL	200mW	Industrial Temperature	N	4.85
TLK2201BI	Single-Ch. 10:1 Gigabit Ethernet Xcvr	1.2 to 1.6Gbps	1-LVPECL	10-LVTTL	200mW	JTAG; 5-Bit DDR Mode, Industrial Temperature Qualified	N	4.65
TLK2201AJR	Single-Ch. 10:1 Gigabit Ethernet Xcvr	1.0 to 1.6Gbps	1-LVPECL	10-LVTTL	200mW	MicroStar Junior™ 5mm x 5mm LGA	N	4.25
TLK2208B	Eight-Ch. of 10:1 Gigabit Ethernet Xcvr	1.0 to 1.3Gbps	8-VML	4/5-Bit/Ch. (Nibble DDR Mode), 8/10-Bit/Ch. (Multiplex Ch. Mode)	1W	JTAG, MDIO Supported	N	31.50
TLK2226	Ch. 16:1 Gigabit Ethernet Xcvr	Six-1.0 to 1.3Gbps	6-VML	4/5-Bit RTBI or RGMII	<1.5W	MDIO Supported 100-FX Mode Support	N	19.65
TLK3118	Four-Ch. 10/8:1 Xcvr with (XAUI) Full Redundancy	2.5 to 3.125Gbps/Ch.	4x 3.125 Gbps LVPECL (XAUI)	8/10-HSTLx4 (XGMII)	<2W	Full Redundancy for Four Channels (XAUI)	N	80.00
TLK3134	Four-Ch. Multi-Rate Xcvr	0.6 to 3.75Gbps	4x 3.125 Gbps CML (XAUI)	8/10-HSTLx4 (XGMII)	400mW/Ch.	Built-In Ref. Clock Jitter Cleaner	N	35.00
TLK3132	Two-Ch. Multi-Rate Xcvr	0.6 to 3.75Gbps	2x 3.125 CML	8/10-HSTLx2	400mW/Ch.	Built-In Ref. Clock Jitter Cleaner	N	Web
TLK3131	Single-Ch. Multi-Rate Xcvr	0.6 to 3.75Gbps	1x 3.125 CML	8/10-HSTLx2	400mW/Ch.	Built-In Ref. Clock Jitter Cleaner	N	Web
TLK6002	Dual-Ch Multi-Rate Xcvr	0.47 to 6.25Gbps	2x 6.25Gbps CML	20-HSTL	500mW/Ch.	Integrated Latency Measurement Function for CPRI/OBSAI	N	Web

*Suggested resale price in U.S. dollars in quantities of 1,000. See www.ti.com/hirel for HiRel options.

→ Communications – PECL-ECL Buffers/Translators

PECL/ECL 1:2 Fanout Buffer

SN65LVEP11

Get samples and datasheets at: www.ti.com/sc/device/SN65LVEP11

Key Features

- 1:2 PECL/ECL fanout buffer
- Support for clock frequencies >3.0GHz
- 240ps typical propagation delay
- Q output will default low when input is open or at VEE
- Drop-in compatible to MC10LVEP11, MC100LVEP11
- LVDS input compatible

Applications

- Clock/data buffering
- Clock fanout
- Level translation
- High-speed network routing in wireless base stations

The SN65LVEP11 is a differential 1:2 PECL/ECL fanout buffer. The device includes circuitry to maintain known logic levels when the inputs are in an open condition. Single-ended clock input operation is limited to $V_{CC} \geq 3V$ in PECL mode, or $V_{EE} \leq 3V$ in NECL mode. The device is housed in an industry-standard SOIC-8 package and is also available in a TSSOP-8 package option.

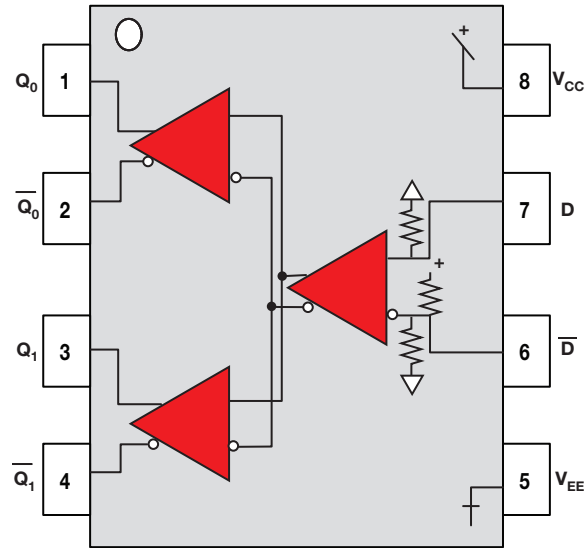

SN65LVEP11 functional block diagram

PECL/ECL Buffers/Translators

Device	No. of Tx	No. of Rx	Input Signal	Output Signal	Frequency	Tpd typ (pS)	ICC Max (mA)	ESD HBM (kV)	Supply Voltage (V)	HiRel Avail.	Package(s)	Pinout	Price*
SN65EL11	2	1	ECL/PECL	ECL/PECL	1.25GHz	265	32	3	5	N	SOIC-8, TSSOP-8	MC10EL11, MC100EL11	Web
SN65EL16	1	1	ECL	TTL	2GHz	250	23	3	5	N	SOIC-8, TSSOP-8	MC10EL16, MC100EL16	Web
SN65ELT20	1	1	TTL	PECL	500Hz	820	16	3	5	N	SOIC-8, TSSOP-8	MC10ELT20, MC100ELT20	Web
SN65ELT21	1	1	TTL	PECL	150Hz	3000	25	3	5	N	SOIC-8, TSSOP-8	MC10ELT21, MC100ELT21	Web
SN65ELT22	2	2	TTL	PECL	500Hz	1200	22	3	5	N	SOIC-8, TSSOP-8	MC10ELT22, MC100ELT22	Web
SN65ELT23	2	2	PECL	TTL	150Hz	3500	27	3	5	N	SOIC-8, TSSOP-8	MC10ELT23, MC100ELT23	Web
SN65EPT21	1	1	LVTTTL	LVPECL	1.25GHz	420	26	3	3.3	N	SOIC-8, TSSOP-8	MC10EPT21, MC100EPT21	Web
SN65EPT22	2	2	LVTTTL	LVPECL	1.25GHz	420	50	3	3.3	N	SOIC-8, TSSOP-8	MC10EPT22, MC100EPT22	Web
SN65EPT23	2	2	LVPECL	LVTTTL	1.25GHz	420	25	3	3.3	N	SOIC-8, TSSOP-8	MC10EPT23, MC100EPT23	Web
SN65LVEL11	2	1	ECL	ECL	1.5GHz	265	26	3	2.5 to 3.3	N	SOIC-8, TSSOP-8	MC10LVEL11, MC100LVEL11	Web
SN65LVELT22	2	2	LVTTTL	LVPECL	400Hz	350	33	3	3.3	N	SOIC-8, TSSOP-8	MC10LVEL22, MC100LVEL22	Web
SN65LVELT23	2	2	LVPECL	LVTTTL	100Hz	3500	27	3	3.3	N	SOIC-8, TSSOP-8	MC10LVELT23, MC100LVELT23	Web
SN65LVEP11	2	1	ECL/PECL	ECL/PECL	3GHz	240	45	3	2.5-3.3	N	SOIC-8, TSSOP-8	MC10LVEP11, MC100LVEP11	Web

*Suggested resale price in U.S. dollars in quantities of 1,000.

→ Consumer/Computing – Redriver/Equalizer

Two Channel SATA 6Gbps Redriver/Equalizer

SN75LVCP601

Get samples and datasheets at: www.ti.com/sc/device/sn75lvcp601

Key Features

- Single device supports 1.5/3/6Gbps two-channel redriver with fixed performance settings
- Integrated output squelch
- Programmable Rx/Tx equalization and de-emphasis width control
- Power-save feature lowers power by >80% in auto low-power mode
- Low power
 - <220mW typ
 - <50mW in auto low-power mode
 - <5mW in standby mode
- Excellent jitter and loss compensation capability to over 24in (61cm) FR4 trace
- Pin-compatible to LVCP412A/MAX4951

Applications

- Notebooks, desktops, docking stations, servers and workstations

SN75LVCP601 is a dual-channel, single-lane SATA redriver and signal conditioner supporting data rates up to 6Gbps. The device complies with SATA physical link 2m and 3i specifications. SN75LVCP601 operates from a single 3.3V supply and has 100Ω line termination with a self-biasing feature, making the device suitable for AC coupling. The inputs incorporate an out-of-band (OOB) detector, which automatically squelches the output while maintaining a stable common-mode voltage compliant to the SATA link. The device is also designed to handle spread-spectrum clocking (SSC) transmission per the SATA specification.

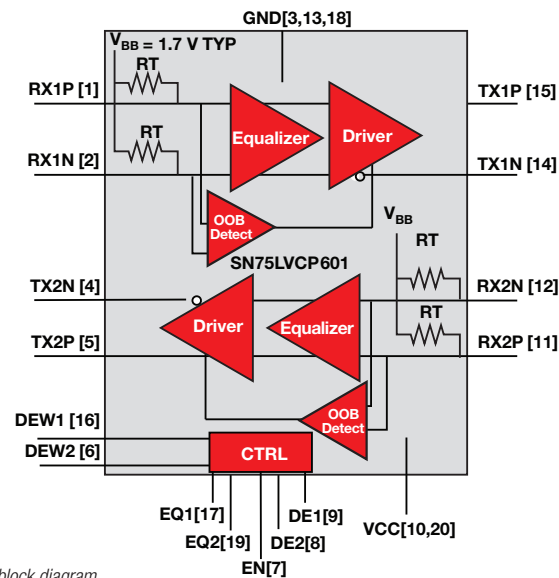

SN75LVCP601 functional block diagram

Redriver/Equalizer

Device	Description	Protocol	Max Speed (Gbps)	No. of Channels	Sleep Mode Power (mW)	HiRel Avail.	Package	Price*
SN65LVPE501	Dual-Channel x1 PCI Express Gen II Redriver/Equalizer	PCIe Gen2	5	2	5	N	VQFN-24	4.00
SN65LVPE502	Dual-Channel USB3.0 Redriver/Equalizer	SuperSpeed USB	5	2	5	N	VQFN-24	4.25
SN65LVPE504	Quad Channel (Half x4 Lane) PCI Express Gen II Redriver/Equalizer	PCIe Gen2	5	4	10	N	TQFN-42	5.40
SN75LVCP412	2-Channel SATA 3Gbps Repeater	SATA	3	2	5	N	QFN-20	1.40
SN75LVCP412A	2-Channel SATA 3Gbps Redriver	SATA	3	2	2.1	N	QFN-20	1.65
SN75LVCP412CD	2-Channel SATA 3Gbps Redriver with Cable Detect	SATA	3	2	2.1	N	QFN-20	1.80
SN75LVCP422	2-Channel SATA 3Gbps Repeater	SATA	3	2	5	N	SSOP-20	1.40
SN75LVCP601	2-Channel SATA 6Gbps Redriver/Equalizer	SATA	6	2	5	N	QFN-20	2.00
SN75LVCP600	1.5/3.0/6.0Gbps Single Channel SATA Redriver	SATA	6	1	10	N	WSO8-8	1.00
SN75LVCP600S	1.5/3.0/6.0Gbps Single Channel SATA/SAS Redriver	SATA or SAS	6	1	10	N	WSO10-10	1.10

*Suggested resale price in U.S. dollars in quantities of 1,000.

New products are listed in bold red. Preview products are listed in bold blue.

→ Consumer/Computing – USB

SuperSpeed USB Transceiver with PIPE3 and ULPI Interfaces

TUSB1310

Get samples and datasheets at: www.ti.com/sc/device/TUSB1310

Key Features

- SuperSpeed USB (USB 3.0) compliant
 - One 5.0Gbps SuperSpeed connection
 - One 480Mbps HS/FS/LS connection
- Receiver sensitivity of less than 50mV differential peak-to-peak is twice as good as required by the specification, allowing for simpler board layout and longer cable usage to ensure broader compatibility
- Digital interface
 - PIPE3 for SuperSpeed signal path
 - ULPI for high-speed, full-speed and low-speed signal path

The TUSB1310 is a single-port, 5.0Gbps USB 3.0 physical layer transceiver operating off of a single crystal or an external reference clock. The TUSB1310 provides a clock to USB link layer controllers. The single reference clock allows the TUSB1310 to provide a cost-effective USB 3.0 solution with few external components and a minimum implementation cost.

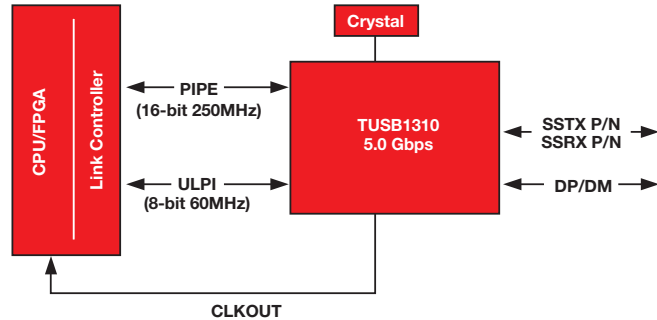

TUSB1310 functional block diagram

Applications

- Surveillance cameras
- High-speed data acquisition systems

SP3T Switch with Impedance Detection Micro-USB Switch to Support USB, UART, Audio and Charger

TSU5511

PREVIEW*

Get samples and datasheets at: www.ti.com/sc/device/TSU5511

Key Features

- Compatible accessories
 - USB data cable
 - UART cable
 - Charger (dedicated or host/hub)
 - Stereo headset with mic
- Integrated LDOs for VREF and mic bias
- USB path supports USB 2.0 high speed
- Audio path provides negative rail support and click/pop reduction
- 1.8V compatible I²C interface
- ESD performance tested per JESD 22
 - 2000V human body model (A114-B, Class II)
 - 1000V charged-device model (C101)
- ESD perf. DP/D</ID/VBUS to GND
 - ±8kV contact discharge (IEC 61000-4-2)
 - ±15kV air gap discharge (IEC 61000-4-2)

The TSU5511 is designed to interface cell phone UART, USB and audio chips with external peripherals via a micro-USB connector. The switch features impedance detection for identification of various accessories that are attached through DP and DM of the micro-USB port. When an accessory is plugged into the micro-USB port, the switch uses a detection mechanism to identify the accessory. It will then switch to the appropriate channel: data, audio or UART.

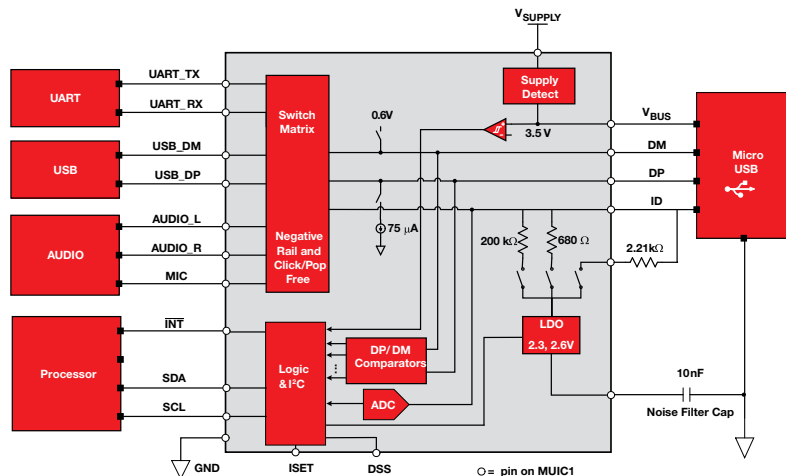

TSU5511 functional block diagram

*Expected release date: Q2 2011

→ Consumer/Computing – USB

SuperSpeed USB-to-SATA bridge TUSB9261

Get samples and datasheets at: www.ti.com/sc/device/TUSB9261

Key Features

- Interface supports interoperability with all host platforms and the latest high-performance storage drives to enable ultra-fast, sync-and-go user experience
 - SATA revision 2.6-compliant
 - USB 2.0 HS/FS and USB 3.0 SS
 - Attached SCSI protocol
 - Mass storage class bulk-only transport
 - HID class
 - Firmware update support
- Receiver sensitivity of less than 50mV differential peak-to-peak is twice as good as required by the specification, allowing for simpler board layout and longer cable usage to ensure broader compatibility

The TUSB9261 is a SuperSpeed USB function controller with integrated USB-compliant transceivers. It is intended as a USB-to-SATA bridge for storage devices using the SATA interface. The TUSB9261 is designed to use both the fast performance of the state machine and the programmability and flexibility of the embedded microcontroller (MCU) and firmware. With the elaborate balance between the MCU and the state machine, it provides a bridge solution to meet both performance and flexibility requirements of next-generation external storage devices.

Applications

- External storage:
 - SSDs
 - HDDs
 - Optical drives

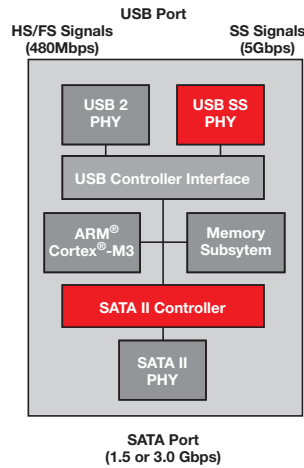

TUSB9261 functional block diagram

SuperSpeed USB Host Controllers TUSB7320/40

NEW

Get samples and datasheets at: www.ti.com/sc/device/TUSB7320 or www.ti.com/sc/device/TUSB7340

Key Features

- USB 3.0-compliant xHCI host controller
- Downstream ports support SuperSpeed, high-speed, full-speed/low-speed connections
- Each downstream port
 - May be independently enabled or disabled
 - Has adjustments for transmit swing, de-emphasis and equalization settings
 - May be marked as removable/non-removable
 - Has independent power control and overcurrent detection
- Best-in-class adaptive receiver equalizer design

The TUSB7320/40 are USB 3.0 xHCI-compliant host controllers that support up to four downstream ports. Both parts are available in a pin-compatible 100-pin RKM package. The TUSB7320/40 interface to the host system via a PCIe x1 Gen 2 interface and provide SuperSpeed, high-speed, full-speed or low-speed connections on the downstream USB ports.

Applications

- PCIe host add-in cards
- Desktop PCs
- Notebook PCs

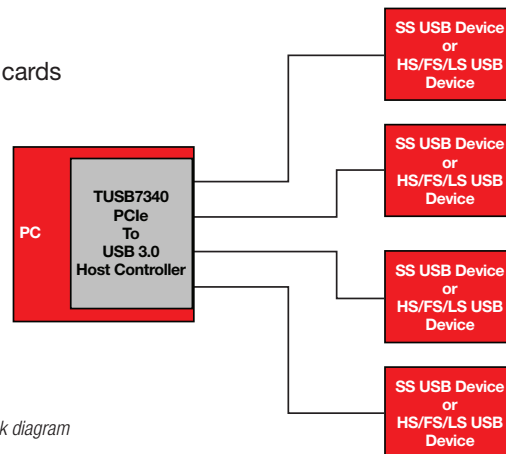

TUSB7320/40 functional block diagram

 **Consumer/Computing – USB**

USB

Device	Description	Max USB Speed	Application Processor Interface	ESD HBM (kV)	HiRel Avail.	Package(s)	Price*
USB Transceivers (PHYs)							
TUSB1105	Advanced USB Full-Speed Transceiver	Full	Single or Differential	±15	N	QFN-16	0.55
TUSB1106	Advanced USB Full-Speed Transceiver	Full	Differential	±15	N	QFN-16, TSSOP-16	0.55
TUSB1210	USB 2.0 ULPI Transceiver	High	ULPI	±2	N	QFN-32	Call
TUSB1211	USB 2.0 ULPI Transceiver with USB Charger Detection	High	ULPI	±2	N	BGA-36	Call
TUSB1310	SuperSpeed USB Transceiver	SuperSpeed	ULPI and PIPE3	±0.5	N	BGA-167	6.00
TUSB2551A	Advanced USB Full-Speed Transceiver	Full	Single	±15	N	QFN-16	0.55

Device	Description	Max USB Speed	Integrated MCU	Out End-Points	In End-Points	MCU Code Space (kB)	HiRel Avail.	Package(s)	Price*
USB Peripherals (Functions)									
TUSB3210	General-Purpose Function Controller	Full	8052	3	3	8	N	LQFP-64	1.15
TUSB3410	USB-to-Serial Bridge	Full	8052	3	3	16	Y	LQFP-32, QFN-32	1.20
TUSB6250	USB-to-IDE (ATA/ATAPI) Bridge	High	8051 WARP	4	4	32	N	TQFP-80	1.95
TUSB9260	USB-to-SATA Bridge	SuperSpeed	Cortex®-M3	5	5	64	N	HTQFP-64	3.00
TUSB9261	USB-to-SATA Bridge	SuperSpeed	Cortex-M3	5	5	64	N	HTQFP-64	3.00

Device	Description	Max USB Speed	Integrated MCU	Downstream Ports	HiRel Avail.	Package(s)	Price*
USB Hubs and Compound Devices							
TUSB2036	2/3-Port USB Full-Speed Capable Hub	Full	—	3	N	LQFP-32	1.15
TUSB2046B	4-Port USB Full-Speed Capable Hub	Full	—	4	Y	LQFP-32, QFN-32	1.20
TUSB2077A	7-Port USB Full-Speed Capable Hub	Full	—	7	N	LQFP-48	1.95
TUSB2136	2-Port USB Full-Speed Capable Hub with Integrated 8052 MCU	Full	8052	2	N	LQFP-64	4.10
TUSB8040	4-Port USB SuperSpeed Hub	SuperSpeed	—	4	N	BGA-167, QFP-80	Call

Device	Description	Max USB Speed	Local Bus	Max No. Host Ports	HiRel Avail.	Package(s)	Price*
USB Host and On-the-Go (OTG)							
TUSB6020	USB 2.0 High-Speed On-the-Go Local Bus Interface Bridge Controller	High	VLYNQ™	1	Y	BGA-80, TQFP-80	6.00
TUSB7320	PCI Express to SuperSpeed USB xHCI with 2 USB 3.0 Ports	SuperSpeed	PCIe Gen2	2	N	mRQFN-100	Call
TUSB7340	PCI Express to SuperSpeed USB xHCI with 4 USB 3.0 Ports	SuperSpeed	PCIe Gen2	4	Y	mRQFN-100	Call

*Suggested resale price in U.S. dollars in quantities of 1,000. See www.ti.com/hirel for HiRel options.

New products are listed in **bold red**. Preview products are listed in **bold blue**.

→ Consumer/Computing – 1394

IEEE P1394b Three-Port Cable Transceiver Arbiter

TSB81BA3E

Get samples, datasheets, evaluation modules and app reports at: www.ti.com/sc/device/TSB81BA3E

Key Features

- Fully supports provisions of IEEE P1394b revision 1.33+ at 1Gb signaling rates
- Fully supports provisions of IEEE 1394a-2000 and 1394-1995 standard for high-performance serial bus
- Fully interoperable with FireWire®, i.LINK®, and SB1394™, implementation of IEEE Std 1394
- Provides three fully backward-compatible, (1394a-2000 fully compliant) bilingual P1394b cable ports at up to 800Mbps
- Provides three 1394a-2000 fully compliant cable ports at 100/200/400 Mbps
- Power-down features to conserve energy in battery-powered applications
- Low-power sleep mode
- Data interface to link-layer controller pin-selectable from 1394a-2000 mode (2/4/8 parallel bits at 49.152MHz) or 1394b mode (8 parallel bits at 98.304MHz)

Applications

- Storage devices
- Consumer electronics
- Desktop PCs

The TSB81BA3E provides the digital and analog transceiver functions needed to implement a three-port node in a cable-based IEEE 1394 network. The transceivers include circuitry to monitor the line conditions as needed for determining connection status, for initialization and arbitration, and for packet reception and transmission.

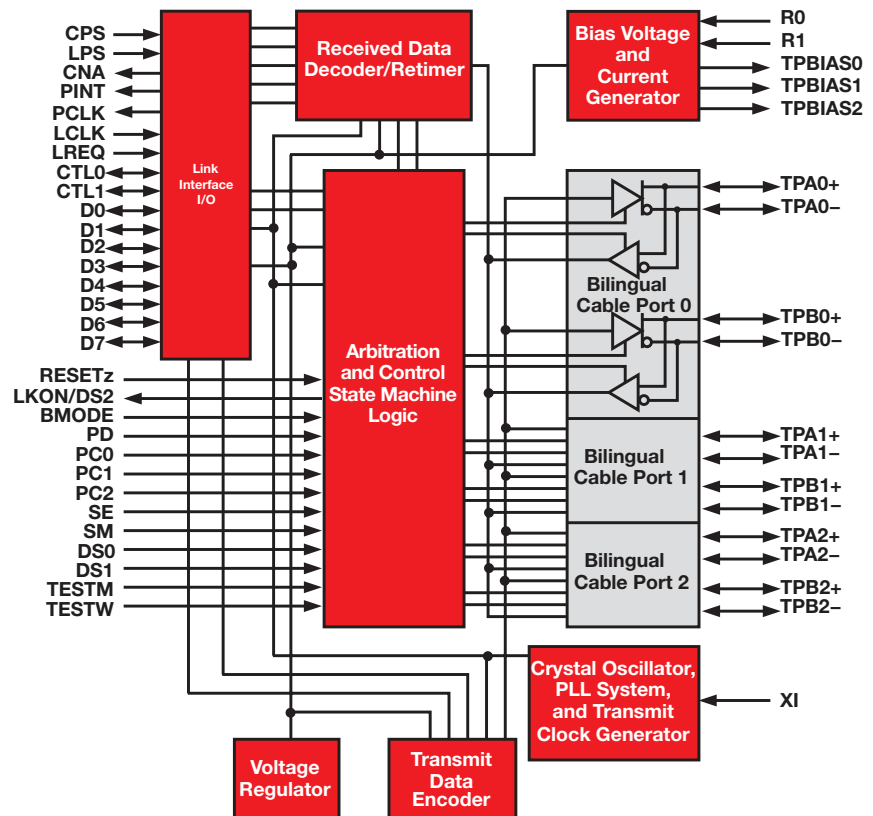

TSB81BA3E block diagram

→ Consumer/Computing – 1394

1394

Device	Description	Ports	Voltage (V)	Data Rate (Mbps)	HiRel Avail.	Package(s)	Price*
1394 PHY							
TSB41AB1	IEEE 1394a One-Port Cable Transceiver/Arbiter	1	3.3	Up to 400	N	HTQFP-48/64, BGA-64/80 MicroStar Junior™	1.50
TSB41AB2	IEEE 1394a Two-Port Cable Transceiver/Arbiter	2	3.3	Up to 400	N	HTQFP-64	1.85
TSB41AB3	IEEE 1394a Three-Port Cable Transceiver/Arbiter	3	3.3	Up to 400	Y	HTQFP-80	3.00
TSB41BA3D	S400-Capable 1394b Physical Layer (PHY)	3	3.3	Up to 400	N	HTQFP-80	6.40
TSB81BA3E	IEEE P1394b Three-Port Cable Transceiver Arbiter	3	1.8, 3.3	Up to 800	Y	BGA-168, HTQFP-80	5.40

Device	Description	FIFO	Voltage (V)	Data Rate (Mbps)	HiRel Avail.	Package	Price*
1394 Link Layer							
TSB12LV32	General-Purpose Link Layer Controller (GP2Lynx)	4	3.3	Up to 400	Y	LQFP-100	6.05
TSB42AC3	High-Performance 1394-1995 Link Layer for Industrial and Bridge Applications	10	3.3	Up to 400	N	TQFP-100	9.50
TSB82AA2B	1394b OHCI-Lynx™ Controller	11	3.3	Up to 800	Y	LQFP-144	2.65

Device	Description	FIFO	Ports	Voltage (V)	Data Rate (Mbps)	HiRel Avail.	Package(s)	Price*
1394 Integrated Devices								
TSB43AB21A	OHCI 1.1, 1394a Link Layer Controller Integrated with 1394a, 400 Mbps, 1-Port PHY	9	1	3.3	Up to 400	Y	TQFP-128	4.45
TSB43AB22A	OHCI 1.1, 1394a Link Layer Controller Integrated with 1394a, 400 Mbps, 2-Port PHY	9	2	3.3	Up to 400	N	TQFP-128	3.80
TSB43AB23	OHCI 1.1, 1394a Link Layer Controller Integrated with 1394a, 400Mbps, 3-Port PHY	9	3	3.3	Up to 400	Y	TQFP-128, LQFP-144	4.25
TSB43EB42	IEEE Std 1394a-2000 Consumer Electronics Solution	—	2	1.5, 3.3	Up to 400	N	BGA-144 MicroStar Junior™	7.95
TSB83AA22C	IEEE Std 1394b-2002 PHY and OHCI Link Device	11	2	1.95, 3.3	Up to 800	N	BGA-168	8.50
TSB83AA23	Integrated IEEE-1394.B OHCI Link and 3-Port S800 PHY	11	3	1.95, 3.3	Up to 800	N	NFBGA-167	9.00
XIO2213B	x1 PCIe-to-1394b OHCI Host Controller and 3-Port S800 PHY	8	3	1.5, 1.95, 3.3	Up to 800	N	NFBGA-167, BGA-168	5.75
XIO2221	x1 PCIe-to-1394b OHCI Host Controller and 1-Port S800 PHY	8	1	1.5, 3.3	Up to 800	N	NFBGA-167	4.90

*Suggested resale price in U.S. dollars in quantities of 1,000. See www.ti.com/hirel for HiRel options.

New products are listed in bold red.

→ Consumer/Computing – Display Port Switch/Redriver

DisplayPort 1:2 Switch with Integrated TMDS Translator

SN75DP122A

Get samples and datasheets at: www.ti.com/sc/device/sn75dp122a

Key Features

- One input port to one of two output ports
- Integrated TMDS level translator with receiver equalization
- DP port supports data rates up to 2.7Gbps
- DP port supports dual-mode DisplayPort
- DP port output waveform mimics input waveform characteristics
- TMDS port supports data rates up to 2.5Gbps
- Integrated I²C logic block for DVI/HDMI connector recognition

The SN75DP122A is a one dual-mode DisplayPort input to one dual-mode DisplayPort output or one TMDS output. The TMDS output has a built-in level translator compliant with Digital Video Interface (DVI) 1.0 and High Definition Multimedia Interface (HDMI) 1.3b. The DisplayPort output follows the input signal in a manner that provides the highest level of signal integrity while supporting the EMI benefits of spread-spectrum clocking. Through the SN75DP122A, data rates of up to 2.7Gbps through each link for a total throughput of up to 10.8Gbps can be realized. The SN75DP122A supports Display Port Spec 1.1a. In addition to the switching of the DisplayPort high-speed signal lines, the SN75DP122A also supports the switching of the bidirectional auxiliary (AUX), Hot Plug Detect (HPD) and Cable Adapter Detect (CAD) channels.

Applications

- Personal computer market
 - Desktop PC
 - Notebook PC
 - Docking station
 - Standalone video card

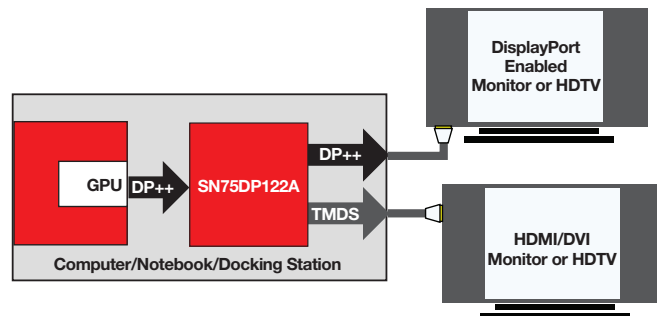

SN75DP122A functional block diagram

DisplayPort Switch/Redriver

Device	Description	No. of DisplayPort Dual Mode Inputs	No. of TMDS Outputs	No. of DisplayPort Dual Mode Outputs	HiRel Avail.	Package(s)	Price*
SN75DP118	Display Port 1:1 Repeater	1	—	1	N	VQFN-36	1.20
SN75DP119	Embedded DisplayPort (eDP) Repeater	1	—	1	N	VQFN-14, VQFN-36	0.80
SN75DP119LV	1.1V Embedded DisplayPort (eDP) Repeater	1	—	1	N	VQFN-14	Call
SN75DP120	Display Port 1:1 Dual-Mode Repeater	1	—	1	N	VQFN-36	1.50
SN75DP121	2-Lane Embedded DisplayPort (eDP) 2:1 Signal Conditioner	1	—	2	N	QFN-32	Call
SN75DP122A	DisplayPort 1:2 Switch with Integrated TMDS Translator	1	1	1	N	QFN-56	1.90
SN75DP128A	DisplayPort 1:2 Switch	1	—	2	N	QFN-56	1.65
SN75DP129	DisplayPort to TMDS Translator	1	1	—	N	VQFN-36	1.30
SN75DP130	5.4Gbps DisplayPort Redriver	1	—	1	N	QFN-48	Call
SN75DP139	DisplayPort to TMDS Translator	1	1	—	N	VQFN-48	1.05
SN75DP219	2-Lane Embedded 5.4Gbps DisplayPort (eDP) Signal Conditioner	1	—	1	N	QFN-14	Call
SN75DP221	2-Lane Embedded 5.4Gbps DisplayPort (eDP) 2:1 Signal Conditioner	1	—	2	N	QFN-32	Call
SN75DP222	5.4Gbps DisplayPort 2x2 Redriver	2	—	2	N	QFN-64	Call

*Suggested resale price in U.S. dollars in quantities of 1,000.

Preview products are listed in bold blue.

→ Consumer/Computing – FlatLink™ 3G Transmitter

FlatLink™ 10-135MHz LVDS Transmitter

SN75LVDS83B

Get samples and datasheets at: www.ti.com/sc/device/sn75lvds83b

Key Features

- LVDS display SERDES interfaces directly to LCD display panels with integrated LVDS
- 1.8V up to 3.3V tolerant data inputs to connect directly to low-power, low-voltage application and graphic processors
- Transfer rate up to 135Mpps (megapixels per second); pixel clock frequency range 10MHz to 135MHz
- Suited for display resolutions ranging from HVGA up to HD with low EMI
- 28 data channels plus clock In low-voltage TTL to 4 data channels plus clock out low-voltage differential
- Consumes less than 1mW when disabled

Applications

- LCD display panel drivers
- UMPC and netbook PCs
- Digital picture frame

The SN75LVDS83B FlatLink™ LVDS transmitter contains four 7-bit parallel-load serial-out shift registers, a 7x clock synthesizer, and five low-voltage differential signaling (LVDS) line drivers in a single integrated circuit. These functions allow 28 bits of single-ended LVTTTL data to be synchronously transmitted over five balanced-pair conductors for receipt by a compatible receiver, such as the SN75LVDS82 and LCD panels with integrated LVDS receiver.

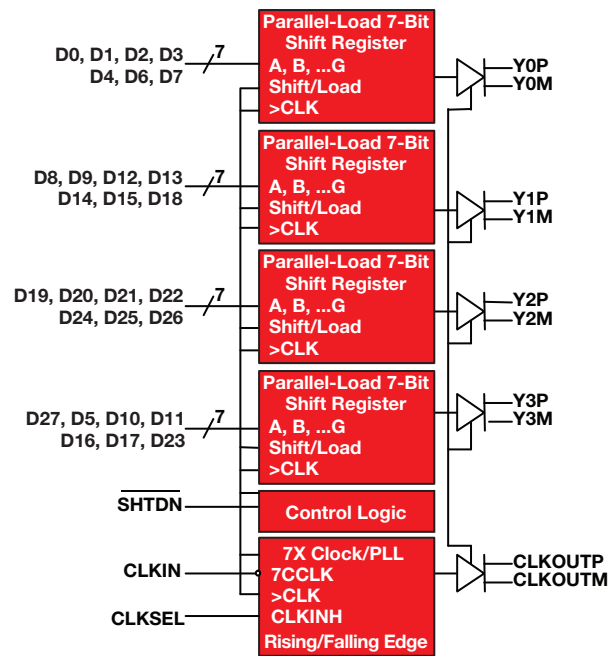

SN75lvds83b functional block diagram

FlatLink™ LVDS Transmitters

Device	Description	Parallel Inputs or Outputs	Serial Channels	Data Throughput (Mbps)	PLL Frequency (MHz)	Supply Voltage (V)	HiRel Avail.	Package	Price*
FlatLink LVDS Receiver									
SN75LVDS86A	FlatLink Receiver	21	3	1428	32 to 68	3.3	N	TSSOP-48	2.40
SN75LVDS82	FlatLink Receiver	28	4	1904	31 to 68	3.3	N	TSSOP-56	2.45

Device	Description	Parallel Inputs or Outputs	Serial Channels	Data Throughput (Mbps)	PLL Frequency (MHz)	Supply Voltage (V)	HiRel Avail.	Package(s)	Price*
FlatLink LVDS Transmitter									
SN75LVDS84A	FlatLink Transmitter	21	3	1575	31 to 75	3.3	N	TSSOP-48	2.35
SN75LVDS83B	FlatLink 10-135MHz Transmitter	28	4	3780	10 to 135	3.3	N	BGA-56 MicroStar Junior™, TSSOP-56	2.60

*Suggested resale price in U.S. dollars in quantities of 1,000.

→ Consumer/Computing – Flatlink™ 3G LVDS Transmitter

FlatLink™ LVDS (continued)

Device	Description	Parallel Inputs or Outputs	Serial Channels	Data Throughput (Mbps)	PLL Frequency (MHz)	Supply Voltage (V)	HiRel Avail.	Package	Price*
FlatLink 3G LVDS Receiver									
SN65LVDS302	Programmable 27-Bit Display Serial Interface Receiver	27	3	1755	4 to 65	1.8	N	BGA-80 MicroStar Junior™	2.25
SN65LVDS304	QVGA-VGA 27-Bit Display Serial Interface Receiver	27	2	810	4 to 30	1.8	N	BGA-80 MicroStar Junior	2.05
SN65LVDS306	QVGA-HVGA 27-Bit Display Serial Interface Receiver	27	1	405	4 to 15	1.8	N	BGA-80 MicroStar Junior	1.85
SN65LVDS308	QVGA-VGA 27-Bit Display Serial Interface Receiver	27	2	810	4 to 30	1.8	N	BGA-48 MicroStar Junior	1.85
SN65LVDS310	QVGA-HVGA 27-Bit Display Serial Interface Receiver	27	1	405	4 to 15	1.8	N	BGA-48 MicroStar Junior	1.75
FlatLink 3G LVDS Transmitter									
Device	Description	Parallel Inputs or Outputs	Serial Channels	Data Throughput (Mbps)	PLL Frequency (MHz)	Supply Voltage (V)	HiRel Avail.	Package	Price*
SN65LVDS301	Programmable 27-Bit Display Serial Interface Transmitter	27	3	1755	4 to 65	1.8	N	BGA-80 MicroStar Junior	2.25
SN65LVDS303	QVGA-VGA 27-Bit Display Serial Interface Transmitter	27	2	810	4 to 30	1.8	N	BGA-80 MicroStar Junior	2.05
SN65LVDS305	QVGA-HVGA 27-Bit Display Serial Interface Transmitter	27	1	405	4 to 15	1.8	N	BGA-80 MicroStar Junior	1.85
SN65LVDS307	QVGA-VGA 27-Bit Display Serial Interface Transmitter	27	2	810	4 to 30	1.8	N	BGA-48 MicroStar Junior	1.85
SN65LVDS311	Programmable 27-Bit Display Serial Interface Transmitter	27	3	1755	4 to 65	1.8	N	DSBGA-49	2.10

Panelbus™ (DVI) Transmitters and Receivers

Device	Description	Voltage (V)	Receiver/Transceiver Channels	Parallel Outputs	Data Speed (Mbps)	ICC (mA)	HiRel Avail.	Package	Price*
TFP401A	DVI Receiver, 165MHz, HSYNC Jitter Immunity	3.3	3	48	495	400	Y	HTQFP-100	4.00
TFP403	DVI Receiver	3.3	3	48	495	400	N	HTQFP-100	5.45
TFP410	DVI Transmitter, 165MHz	3.3	3	6	495	250	Y	HTQFP-64	3.00

*Suggested resale price in U.S. dollars in quantities of 1,000. See www.ti.com/hirel for HiRel options.

New products are listed in bold red.

→ Consumer/Computing - PCI Express

x1 PCI Express to PCI Bus Translation Bridge

XIO2001

Get samples and datasheets at: www.ti.com/sc/device/xio2001

Key Features

- Full x1 PCI Express throughput
- Fully compliant with PCI Express to PCI/PCI-X bridge specification, revision 1.0
- Fully compliant with PCI Express base specification, revision 2.0
- Fully compliant with PCI local bus specification, revision 2.3
- PCI Express advanced error reporting capability including ECRC support
- Support for D1, D2, D3hot and D3cold
- Utilizes 100MHz differential PCI Express common reference clock or 125MHz
- Single-ended reference clock (optional spread-spectrum reference clock is supported)
- Robust pipeline architecture to minimize transaction latency
- Full PCI local bus 66MHz/32-bit throughput support for six subordinate PCI bus masters with internal configurable 2-level prioritization scheme

Applications

- Notebooks, desktops, docking stations, servers and workstations

The XIO2001 is a single-function PCI Express to PCI translation bridge that is fully compliant to the PCI Express to PCI/PCI-X bridge specification, revision 1.0. For downstream traffic, the bridge simultaneously supports up to eight posted and four non-posted transactions. For upstream traffic, up to six posted and four non-posted transactions are simultaneously supported.

The PCI Express interface supports a x1 link operating at full 250MBP/s packet throughput in each direction simultaneously. Also, the bridge supports advanced error reporting including extended CRC (ECRC) as defined in the PCI Express base specification.

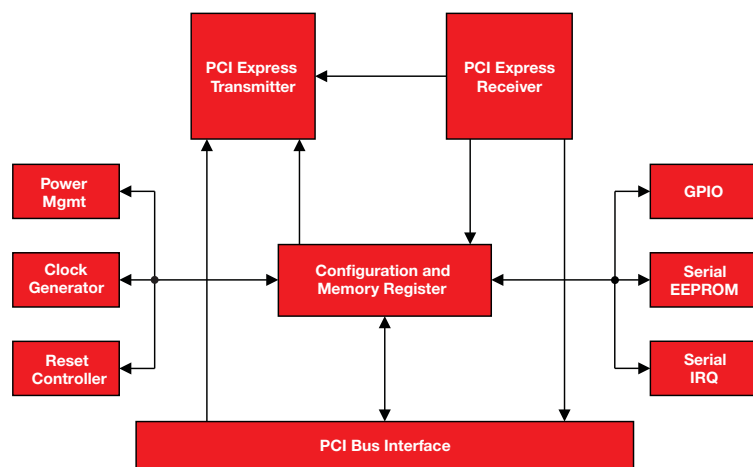

XIO2001 functional block diagram

Interface

→ Consumer/Computing – PCI Express

PCI Express

Device	Description	Supply Voltage (V)	PCIe	Parallel Bus Width	Speed (max) (Mbps)	HiRel Avail.	Package	Price*
PCI Express PHY								
XI01100	x1 PCI Express PHY, Compliant with the PCI Express Base Specification Revision 1.1	3.3, 1.8, 1.5	x1	8, 16	2500	N	BGA-100	7.00

Device	Description	Supply Voltage (V)	PCIe	PCI Bus Masters	Wake/ Beacon Support	HiRel Avail.	Package(s)	Price*
PCI Express Bridge								
XI02001	x1 PCI Express to PCI Bus Translation Bridge	3.3, 1.5	x1	6	Yes	N	BGA-144, BGA-169 MicroStar Junior™	5.50

Device	Description	Supply Voltage (V)	PCIe	Downstream PCIe Ports	Wake/ Beacon Support	HiRel Avail.	Package	Price*
PCI Express Packet Switch								
XI03130	x1 PCI Express 4-Port Fanout Packet Switch	3.3, 1.5	x1	3	Yes	N	BGA-196	10.95

Device	Description	Supply Voltage Range (V)	Architecture	rON (typ) (Ω)	tpd (typ) (ns)	HiRel Avail.	Package	Price*
PCI Express Signal Switches								
TS2PCIE2212	2-Channel PCIe 2:1 Multiplexer/Demultiplexer Passive FET Switch	1.7 to 1.9	2:1	10	0.25	N	BGA-48	1.65
TS2PCIE412	4-Channel PCIe 2:1 Multiplexer/Demultiplexer Passive FET Switch	1.5 to 2.1	2:1	12.5	0.25	N	QFN-42	0.95

PCI Bridges

Device	Description	Speed (MHz)	Expansion Interface (Bits)	Hot Swap	Voltage (V)	HiRel Avail.	Package(s)	Price*
PCI2050B	32-Bit, 66MHz, 9-Master PCI-to-PCI Bridge	66	32	Yes	3.3, 5	N	QFP-208, QFP-208, BGA-257	9.50
PCI2250	32-Bit, 33MHz PCI-to-PCI Bridge, Compact PCI Hot-Swap Friendly, 4-Master	33	32	Friendly	3.3, 5	N	LQFP-176, QFP-160	6.10
PCI2060	32-Bit, 66MHz, 9-Master, Asynchronous PCI-to-PCI Bridge	66	32	Yes	3.3, 5	N	BGA-257	9.50

→ Consumer/Computing – HDMI

TMDS

Device	Description	No. of Inputs	No. of Outputs	Intra-Pair Skew (max) (ps)	Inter-Pair Skew (max) (ps)	ICG (max)	ESD HBM (kV)	HiRel Avail.	Package(s)	Price*
TMDS141	HDMI Hider	1	1	50	100	150	5	N	QFN-40	1.75
TMDS361B	3-to-1 DVI/HDMI Active Switch	3	1	40	100	215	12	N	TQFP-64	1.50
TMDS261B	2-to-1 DVI/HDMI Active Switch	2	1	40	100	215	12	N	TQFP-64	1.35
TMDS442	4-to-2 DVI/HDMI Active Switch	4	2	50	100	550	5	N	TQFP-128	3.45
TS3DV416	2-to-1 Analog FET Switch for HDMI/DVI	2	1	—	—	0.6	2	N	TSSOP-48, TVSOP-48	0.90
TS3DV520E	2-to-1 Analog FET Switch for HDMI/DVI	2	1	—	—	0.6	14	N	QFN-56, QFN-42	1.00

*Suggested resale price in U.S. dollars in quantities of 1,000.

New products are listed in **bold red**.

→ Industrial – CAN Transceivers

Industrial CAN Transceiver

SN65HVD252/253

Get samples and datasheets at: www.ti.com/sc/device/SN65HVD252 and www.ti.com/sc/device/SN65HVD253

Key Features

- DeviceNet™ compliant supporting 64 DeviceNet nodes
- Loopback function (HVD253)
- Bus-fault protection of –36V to +40V
- Power-up/down glitch-free bus I/O
- 3.3V compatible receiver output

Applications

- DeviceNet networks
- Industrial automation
- HVAC networks
- Security systems
- Telecom base station status and control
- CAN open data bus
- SDS data bus
- CAN kingdom data bus

The SN65HVD252 and SN65HVD253 CAN transceivers meet or exceed the specifications of DeviceNet™ and are compatible to the ISO 11898-2:2003 standard for use in applications employing a controller area network (CAN). This device provides differential transmit and receive capability at signaling rates up to 1Mbps. Designed for operation in harsh industrial environments, these devices feature bus-pin voltage protection from –36V to +40V, driver output current limiting and overtemperature driver shutdown.

The V_{REF} pin of the SN65HVD252 is a VCC/2 voltage reference for systems that use split termination. The AB pin of the SN65HVD253 implements a listen-only loopback feature that allows the local node controller to synchronize its baud rate with that of the CAN bus. In loopback mode, the driver differential outputs are placed in high-impedance state, while the receiver bus inputs remain active.

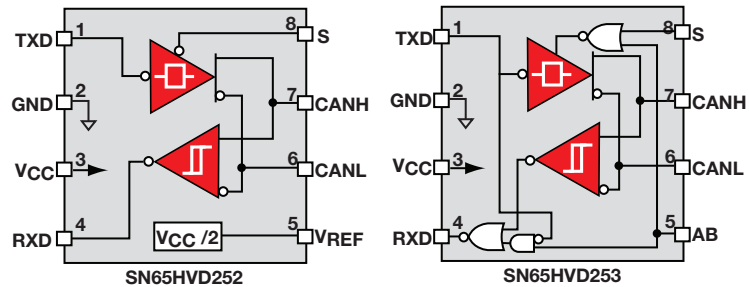

SN65HVD252/53 functional block diagrams

CAN Transceivers

Device	Description	Isolated	Supply Voltage	I/O Levels	Short-Circuit Protection (V)	ESD (kV)	Operating Temp Range (°C)	HiRel Avail.	Price*
SN65HVD251/ SN55HVD251	Improved Replacement for PCA82C250 and PCA82C251/Small QFN Package	No	5V	5V CMOS	–36 to 36	±14	–40 to 125/ –55 to 125	Y	0.90
SN65HVD1040	Improved TJA1040 with Better ESD and Bus Wake Up	No	5V	5V TTL	–27 to 40	±12	–40 to 125	Y	0.60
SN65HVD1050	Improved TJA1050 with Better ESD	No	5V	5V TTL	–27 to 40	±8	–40 to 125	Y	0.45
ISO1050DUB	2.5kVrms Isolated CAN Transceiver	Yes	5V	5V TTL	–27 to 40	±4	–55 to 105	N	1.55
ISO1050DW	5kVrms Isolated CAN Transceiver	Yes	5V	5V TTL	–27 to 40	±4	–55 to 105	N	1.95
SN65HVD230	Standby Mode, Slope Control	No	3.3V	3.3V TTL	–4 to 16	±16	–40 to 85	Y	1.45
SN65HVD231	Sleep Mode, Slope Control	No	3.3V	3.3V TTL	–4 to 16	±16	–40 to 85	Y	1.45
SN65HVD232	Cost Effective	No	3.3V	3.3V TTL	–4 to 16	±16	–40 to 85	Y	1.10
SN65HVD233	Standby Mode, Diagnostic Loop-Back	No	3.3V	3.3V TTL	–36 to 36	±16	–40 to 125	Y	1.50
SN65HVD234	Standby Mode, Sleep Mode	No	3.3V	3.3V TTL	–36 to 36	±16	–40 to 125	N	1.45
SN65HVD235	Standby Mode, Auto Baud Loop-Back	No	3.3V	3.3V TTL	–36 to 36	±16	–40 to 125	N	1.50
DeviceNet™ CAN									
SN65HVD252	DeviceNet Compliant/Low Propagation Delay CAN Device	No	5V	5V TTL	–36 to 40	±12	–40 to 85	N	0.80
SN65HVD253	DeviceNet Compliant/Low Propagation Delay CAN Device with Auto Baud Loop-Back	No	5V	5V TTL	–36 to 40	±12	–40 to 85	N	0.80

*Suggested resale price in U.S. dollars in quantities of 1,000. See www.ti.com/hirel for HiRel options.

New products are listed in bold red.

→ Industrial – Digital Isolators

Low-Power 5kVrms Dual Digital Isolator ISO7520C

Get samples and datasheets at: www.ti.com/sc/device/ISO7520C

Key Features

- Highest signaling rate: 1Mbps
- Propagation delay <20ns
- Low power consumption
- Wide ambient temperature: -40°C to +105°C
- Safety and regulatory approvals:
 - 5kV(rms) for 1 minute per UL 1577
 - CSA component acceptance notice 5A
 - IEC 60747-5-2 (VDE 0884 Rev. 2)
 - IEC 60601-1, 60950-1 and 61010-1 end-equipment standards
- 50kV/μs transient immunity typical
- Operates from 3.3V or 5V supply and logic levels

The ISO7520 provides double galvanic isolation of up to 5kVrms for 1 minute per UL. This digital isolator has two isolated channels with unidirectional channel configurations. Each isolation channel has a logic input and output buffer separated by a silicon oxide (SiO₂) insulation barrier. Used in conjunction with isolated power supplies, these devices prevent noise currents on a data bus or other circuits from entering the local ground and interfering with or damaging sensitive circuitry.

Applications

- Opto-coupler replacement in:
- Medical applications for IEC 60601-1 5kVrms rated
- Industrial field-bus
 - ProfiBus
 - Modbus®
 - DeviceNet™ data buses
- Servo control interfaces
- Motor control

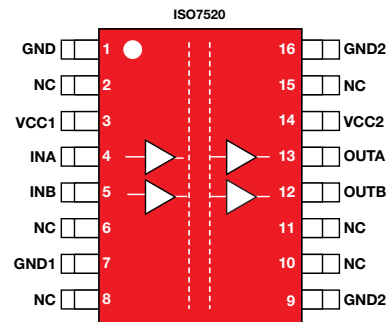

ISO7520 functional block diagram

Isolated 3.3V Full-and Half-Duplex RS-485 Transceivers ISO15/35

Get samples and datasheets at: www.ti.com/sc/device/ISO15 and www.ti.com/sc/device/ISO35

Key Features

- 4000Vpeak isolation, 560Vpeak VIORM
- UL 1577, IEC 60747-5-2 (VDE 0884, Rev 2)
- IEC 61010-1, IEC 60950-1 and CSA approved
- 1/8 UL – up to 256 nodes on a bus
- Meets or exceeds TIA/EIA RS-485 requirements
- Signaling rates up to 1Mbps
- Thermal shutdown protection
- Low bus capacitance – 16pF (typ)
- 50kV/μs typical transient immunity
- Fail-safe rec. for bus open, short, idle
- 3.3V inputs are 5V tolerant

The ISO15 is an isolated half-duplex differential line transceiver, while the ISO35 is an isolated full-duplex differential line driver and receiver for TIA/EIA 485/422 applications. The ISO15M and ISO35M have extended ambient temperature ratings of -55°C to +125°C, while the ISO15 and ISO35 are specified over -40°C to +85°C.

These devices are ideal for long transmission lines, since the ground loop is broken, to allow for a much larger common-mode voltage range. The symmetrical isolation barrier of the device is tested to provide 2500 Vrms of isolation for 60s between the bus-line transceiver and the logic-level interface.

Applications

- Security systems
- Chemical production
- Factory automation
- Motor/motion control
- HVAC and building automation networks
- Networked security stations

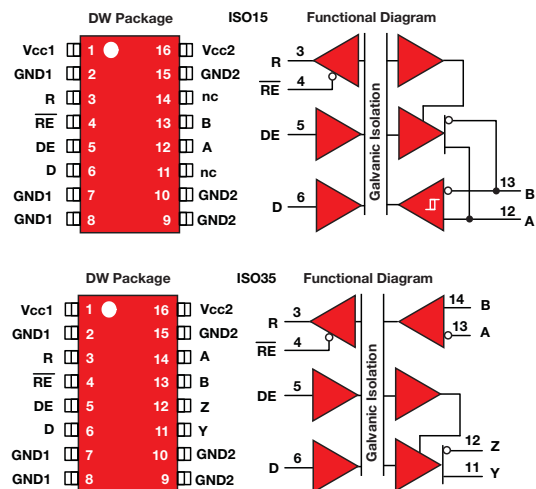

ISO15/35 functional block diagram

 **Industrial – Digital Isolators**
Digital Isolators

Device	Description	Isolation Rating Vrms (UL, VDE, CSA)	Channel Direction	Data Rate (Max) Mbps	Transient Immunity (Min) (kV/μs)	Supply Voltage (V)	HiRel Avail.	Price*
IS0721/M	Single Channel	2500Vrms	1/0	100/150	25	3.3, 5	Y	1.40
IS0722/M	Single Channel with Output Enable	2500Vrms	1/0	100/150	25	3.3, 5	N	1.40
IS0150	Dual Channel Configurable	2400Vrms	Config	80	1.6	5	N	8.10
IS07220A/B/C/M	Dual Channel	2500Vrms	2/0	1/5/25/150	25	3.3, 5	Y	0.95
IS07221A/B/C/M	Dual Channel	2500Vrms	1/1	1/5/25/150	25	3.3, 5	Y	0.95
IS07230A/C/M	Triple Channel	2500Vrms	3/0	1/25/150	25	3.3, 5	N	1.40
IS07231A/C/M	Triple Channel	2500Vrms	2/1	1/25/150	25	3.3, 5	N	1.40
IS07240A/C/CF/M	Quad Channel (F=Fail-safe Low)	2500Vrms	4/0	1/25/25/150	25	3.3, 5	Y	1.75
IS07241A/C/M	Quad Channel	2500Vrms	3/1	1/25/150	25	3.3, 5	Y	1.75
IS07242A/C/M	Quad Channel	2500Vrms	2/2	1/25/150	25	3.3, 5	N	1.75
IS07420/0F/1/1F	Gen II Dual Channel (F=Fail-safe Low)	2500Vrms	2/0 and 1/1	1	25	3.3, 5	Y	1.50
IS07431	Gen II Triple Channel	2500Vrms	2/1	TBD	25	3.3, 5	N	TBD
IS07440/1	Gen II Quad Channel	2500Vrms	4/0 and 3/1	TBD	25	3.3, 5	N	TBD
IS07520C/1C	Dual Channel	5000Vrms	2/0 and 1/1	1	25	3.3, 5	N	1.70
IS07531	Triple Channel	5000Vrms	2/1	TBD	25	3.3, 5	N	TBD
IS07540/1	Quad Channel	5000Vrms	4/0 and 3/1	TBD	25	3.3, 5	N	TBD
IS03082/IS03088	Isolated Half Duplex 5V RS-485	2500Vrms	2/1	0.2/20	25	5	N	2.60
IS03080/IS03086	Isolated Full Duplex 5V RS-485	2500Vrms	2/1	0.2/20	25	5	N	2.60
IS015/M	Isolated Half Duplex 3.3V RS-485	2500Vrms	2/1	1	25	3.3	N	3.00
IS035/M	Isolated Full Duplex 3.3V RS-485	2500Vrms	2/1	1	25	3.3	N	3.00
IS01176	Isolated PROFIBUS RS-485	2500Vrms	2/1	40	25	5	N	3.35
IS01050DUB	Isolated CAN Transceiver	2500Vrms	1/1	1	25	5	N	1.55
IS01050DW	Isolated CAN Transceiver	5000Vrms	1/1	1	25	5	N	1.95
IS03086T	Isolated 5V RS485 with Transformer Driver	2500Vrms	2/1	20	25	5	N	TBD
IS035T	Isolated 3.3V RS485 with Transformer Driver	2500Vrms	2/1	1	25	3.3	N	TBD
IS01176T	Isolated PROFIBUS with Transformer Driver	2500Vrms	2/1	40	25	5	N	TBD
IS055XX	Isolated Gate Drivers	5000Vrms	N/A	10	25	3.3, 5	N	TBD
AMC1200	Isolated Amplifier with G=8	2500Vrms	N/A	N/A	10	-0.3 to 6	N	2.25
AMC1203	Isolated 2nd-Order $\Delta\Sigma$ Modulator	2500Vrms	N/A	20	15	5	N	3.35
AMC1204	Isolated 20MHz $\Delta\Sigma$ Modulator, 16-Bit	2500Vrms	N/A	20	15	3.3, 5	N	3.45

*Suggested resale price in U.S. dollars in quantities of 1,000. See www.ti.com/hirel for HiRel options.

New products are listed in bold red. Preview products are listed in bold blue.

→ Industrial – Ethernet Physical Layer Transceivers

Industrial 10/100 Ethernet PHY

TLK100

Get samples and datasheets at: www.ti.com/sc/device/TLK100

Key Features

- Operates from –40°C to +85°C
- Low power consumption, <200mW typical
- Advanced cable diagnostics
- Error-free operation up to 200 meters under typical conditions
- 3.3V MAC interface
- Auto-MDIX for 10/100 Mbps
- Energy detection mode
- 25MHz clock out
- MII serial management interface (MDC and MDIO)
- Bus I/O protection – ±16kV JEDEC HBM
- IEEE 1149.1 JTAG
- IEEE 802.3 compliant
- Auto-MDIX/auto-negotiation/auto-polarity
- 48-pin TQFP package (7mm × 7mm)

Applications

- Industrial controls and factory automation
- General embedded applications

The TLK100 is a single-port Ethernet PHY for 10BaseT and 100Base TX signaling. It integrates all of the physical-layer functions needed to transmit and receive data on standard twisted-pair cables. This device supports the standard Media Independent Interface (MII) for direct connection to a media access controller (MAC).

The TLK100 is designed for power-supply flexibility and can operate with a single 3.3V power supply or with combinations of 3.3V, 1.8V and 1.1V power supplies for reduced power operation.

The TLK100 uses mixed-signal processing to perform equalization, data recovery and error correction to achieve robust operation over CAT 5 twisted-pair wiring. It not only meets the requirements of IEEE 802.3, but maintains high margins in terms of crosstalk and alien noise.

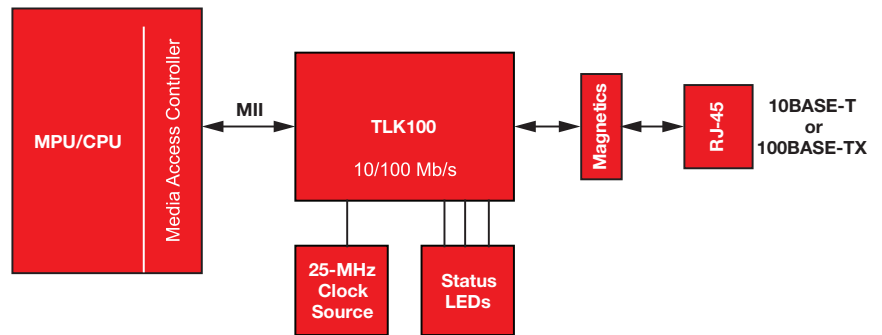

TLK100 functional block diagram

Industrial Ethernet Physical Layer Transceiver

Device	Description	Supply Voltage (V)	Cable Reach (m)	Power (mW)	ESD (kV)	Operating Temp Range (°C)	HiRel Avail.	Package	Price*
TLK100	Single-Port 10/100 Mbps Ethernet PHY	3.3, 1.8, 1.1	200	189**	±16	–40 to +85	N	TQFP-48	2.25

*Suggested resale price in U.S. dollars in quantities of 1,000.

**Triple supply power

→ Industrial – Industrial SERDES

Eight-Channel, 0-34V Digital-Input Serializer with 5V Vcc for Industrial Digital Inputs **SN65HVS885**

Get samples and datasheets at: www.ti.com/sc/device/SN65HVS885

Key Features

- Eight digital sensor inputs
- High-input voltage up to 34V
- Selectable debounce filters from 0ms to 3ms
- Flexible current-limited inputs –0.2mA to 5.2mA
- Field inputs protected to 15kV ESD
- Single 5V supply
- Output drivers for external status LEDs
- Cascadable for more inputs in multiples of eight
- SPI™-compatible interface
- Overtemperature indicator

Applications

- Industrial PCs
- Digital I/O cards
- High-channel-count digital input modules
- Decentralized I/O modules

The SN65HVS885 is an eight-channel, digital-input serializer for high-channel density digital input modules in industrial and building automation. Operating from a 5V supply, the device accepts field input voltages of up to 34V. In combination with galvanic isolators, the device completes the interface between the high voltage signals on the field side and the low-voltage signals on the controller side. Input signals are current limited and then validated by internal debounce filters.

With the addition of few external components, the input switching characteristic can be configured in accordance with IEC61131-2 for Type 1, 2 and 3 sensor switches.

Upon the application of load and clock signals, input data is latched in parallel into the shift register and afterwards clocked out serially.

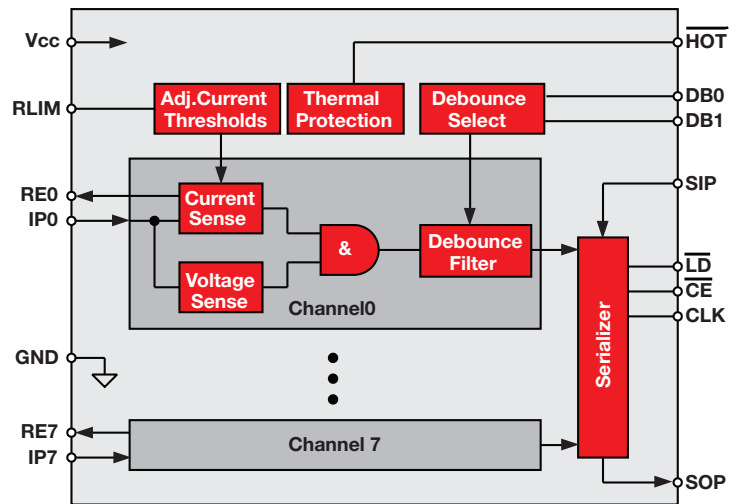

SN65HVS885 functional block diagram

Industrial Serializers

Device	Description	Supply Voltage (V)	I/O Voltage (V)	Parity	Input Data Rate (Mbps)	Temperature Range	Low Voltage Detector	HiRel Avail.	Price*
Industrial Eight-Channel Digital Serializers									
SN65HVS880	Nominal 24V Digital-Input Serializer	18 to 30	0 to 30	No	1	-40 to 85	Yes: 15V	N	1.90
SN65HVS881	0-34V Digital-Input Serializer with Parity	10 to 34	0 to 34	Yes	1	-40 to 125	Yes: 15V	N	2.00
SN65HVS882	0-34V Digital-Input Serializer	10 to 34	0 to 34	No	1	-40 to 125	No	N	2.00
SN65HVS885	0-34V Digital-Input Serializer for 5V Systems	4.5 to 5.5	0 to 34	No	1	-40 to 125	No	N	1.80

*Suggested resale price in U.S. dollars in quantities of 1,000.

New products are listed in **bold red**.

→ Industrial – RS-485/RS-422

SymPol™ Transceiver SN65HVD96

Get samples and datasheets at: www.ti.com/sc/device/SN65HVD96

Key Features

- Communicate without errors on normal or reversed-wire bus lines
- Up to 5Mbps signaling
- Industrial temperature range: –40°C to +85°C
- Symmetric polarity receiver
- Receiver hysteresis >100mV
- Connect up to 32 nodes on one bus
- Transient protection on bus pins
 - ±12kV human body model
 - ±25V repetitive transient pulse
- Additional reliability features:
 - Bus standoff from –35V to +40V
 - Driver output short-circuit current limit
 - Automatic thermal shutdown and recovery

Applications

- Camera: surveillance analog
- Camera: surveillance IP network
- HVAC – heating, ventilating and air conditioning

The SN65HVD96 is specifically designed to meet the requirements for a transceiver that operates with no errors if the twisted-pair signal wires are connected normally or reversed. This allows for error-free operation in applications where the signal wires may become inadvertently reversed during installation or maintenance. This feature is corrected internally so no intervention from the controller or operator is required.

Similar to RS-485, these transceivers can be used for point-to-point, multi-drop or multi-point networks. SymPol™ devices are not backwards compatible with, but are an upgrade to, existing RS-485 networks. The pin-out is identical to the industry-standard SN75176 transceiver, allowing direct upgrade from RS-485 to SymPol.

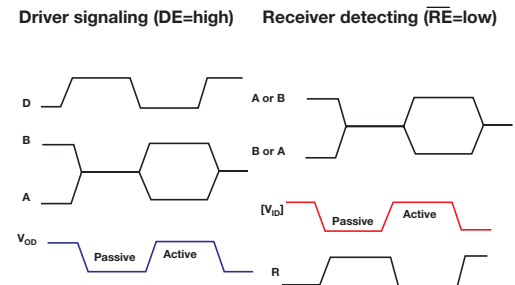
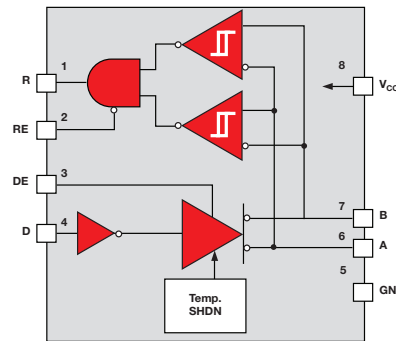

SN65HVD96 functional block diagram

RS-485/RS-422

Device	Description	DR/RX	Duplex	Supply (V)	Isolated	Signaling Rate (Mbps)	ESD (kV)	Receiver Fail-Safe	Nodes	HiRel Avail.	Package(s)	Price*
SN65HVD10/11/12	High/Mid/Low Speed Slew-Rate Control	1/1	Half	3.3	No	32/10/1	16	Short, Open, Idle	256	Y	PDIP/SOIC-8	1.50
SN65HVD13	High Signaling Rate, High Hysteresis	1/1	Half	3.3	No	50	7	Short, Open, Idle	96	N	MSOP/SOIC-8	TBD
SN65HVD30/31/32	No Enables	1/1	Full	3.3	No	26/5/1	16	Short, Open, Idle	256	Y	SOIC-8	1.45
SN65HVD33/34/35	With Enables	1/1	Full	3.3	No	26/5/1	16	Short, Open, Idle	256	Y	SOIC-14	1.45
SN65HVD37	Low Power, High Hysteresis	1/1	Full	3.3	No	20	7	Short, Open, Idle	256	N	SOIC-14	TBD
ISO15/ M	Isolated 3.3V Half Duplex Transceiver	1/1	Half	3.3	Yes	1	16	Short, Open, Idle	256	N	SOIC-16	3.00
ISO35/ M	Isolated 3.3V Full Duplex Transceiver	1/1	Full	3.3	Yes	1	16	Short, Open, Idle	256	N	SOIC-16	3.00
ISO35T	Isolated 3.3V Transceiver with Transformer Driver	1/1	Full	3.3	Yes	1	16	Short, Open, Idle	256	N	SOIC-16	TBD
SN65HVD08	Wide Supply Range: 3V to 5.5V	1/1	Half	3 to 5.5	No	10	16	Short, Open, Idle	256	N	PDIP/SOIC-8	1.65

*Suggested resale price in U.S. dollars in quantities of 1,000. See www.ti.com/hirel for HiRel options.

New products are listed in bold red. Preview products are listed in bold blue.

 **Industrial – RS-485/RS-422**
RS-485/RS-422 (continued)

Device	Description	DR/ RX	Duplex	Supply (V)	Isolated	Signaling Rate (Mbps)	ESD (kV)	Receiver Fail-Safe	Nodes	HiRel Avail	Package(s)	Price*
SN65HVD1780/1/2	Up to ±70V Protected, Wide Supply Range: 3.3V to 5V	1/1	Half	3.3 to 5	No	0.115/1/10	16	Short, Open, Idle	320	N	PDIP/SOIC-8	1.85
SN65HVD1785/6/7	±70V Protected, Wide –20V to +25V Common Mode	1/1	Half	5	No	0.115/1/10	16	Short, Open, Idle	256	N	PDIP/SOIC-8	1.85
SN65HVD1794	±70V Protected, Bus-Pin Invert/Wide Common Mode	1/1	Half	5	No	0.115	16	Short, Open, Idle	256	N	PDIP/SOIC-8	1.95
SN65HVD3082E/5E/8E	Ultra-Low Power, Optimized for Low, Medium and High Speeds	1/1	Half	5	No	0.2/1/20	16	Short, Open, Idle	256	Y	SOIC/PDIP/MSOP-8	0.90
ISO3082/8	±4kV Isolated RS-485 Optimized for Low and High Speeds	1/1	Half	5	Yes	0.2/20	16	Short, Open, Idle	256	N	Wide SOIC-16	2.60
SN65HVD485E	Half Duplex Transceiver	1/1	Half	5	No	10	15	Open	64	Y	PDIP/SOIC/MSOP-8	0.75
SN65HVD20/21/22	±27V Protected and –20V to +25V Common Mode	1/1	Half	5	No	25/5/0.5	16	Short, Open, Idle	256	N	PDIP/SOIC-8	1.40
SN65HVD23/24	Receiver Equalization and –20V to +25V Common Mode	1/1	Half	5	No	25/3	16	Short, Open, Idle	256	N	PDIP/SOIC-8	1.95
SN65LBC176A	Low Power, Fast Signaling, ESD Protection	1/1	Half	5	No	30	12	Open	32	Y	PDIP/SOIC-8	2.65
SN65LBC184	ESD Protection IEC 4-2 Air, Contact and IEC 4-5 Surge	1/1	Half	5	No	0.25	30	Open	128	N	PDIP/SOIC-8	1.30
SN65LBC182	ESD Protection HBM, IEC4-2 Air and Contact	1/1	Half	5	No	0.25	15	Open	128	N	PDIP/SOIC-8	1.05
SN65HVD1791/2/3	±70V Protected, Wide –20V to +25V Common Mode	1/1	Full	5	No	0.115/1/10	16	Short, Open, Idle	256	N	SOIC-14	1.90
SN65HVD3080E/3E/6E	Ultra-Low Power, Optimized for Low, Medium and High Speeds	1/1	Full	5	No	0.2/1/20	15	Short, Open, Idle	256	N	SOIC-14, MSOP-10	1.20
ISO3080/6	±4kV Isolated, Optimized for Low and High Speeds	1/1	Full	5	Yes	0.2/20	16	Short, Open, Idle	256	N	Wide SOIC-16	2.60
ISO3086T	Isolated 5V Transceiver with Transformer Driver	1/1	Full	5	Yes	20	16	Short, Open, Idle	256	N	Wide SOIC-16	TBD
SN65LBC180A	High Signaling Rate with Enables	1/1	Full	5	No	30	15	Open	32	Y	PDIP/SOIC-14	1.50
SN65LBC172A/174A	Quad Drivers, High Signaling Rate	4/0	—	5	No	30	12	—	—	N	PDIP/SOIC-16, SOIC-20	2.65
AM26LV31E	Quad Drivers, High Signaling Rate, IEC 4-2 ESD	4/0	—	3.3	No	64	15	—	—	Y	SO/SOIC/TSSOP/QFN-16	0.90
SN65LBC173A/175A	Quad Receivers, High Signaling Rate, Low Power	0/4	—	5	No	50	6	Short, Open, Idle	32	N	PDIP/SOIC-16	1.65
AM26LV32E	Quad Receivers, High Signaling Rate, IEC 4-2 ESD	0/4	—	3.3	No	64	15	Short, Open, Idle	10	Y	SO/SOIC/TSSOP/QFN-16	1.05
SN65HVD09	9-Channel Parallel Bus Transceivers	9/9	Half	5	No	20	12	Open	32	N	TSSOP-56	3.50
PROFIBUS Transceivers												
HVD1176	PROFIBUS (EN 50170) Transceiver	1/1	Half	5	No	40	10	Short, Open, Idle	160	N	SOIC-8	1.55
ISO1176	Isolated PROFIBUS Transceiver	1/1	Half	5	Yes	40	16	Short, Open, Idle	160	N	SOIC-16	3.35
ISO1176T	Isolated PROFIBUS Transceiver with Transformer Driver	1/1	Half	5	Yes	40	4	Short, Open, Idle	160	N	SOIC-16	TBD
ControlNet™ Transceivers												
SN65HVD61	ControlNet Transceiver	1/1	Half	5	No	10	16	Short	64	N	SOIC-14	5.10
SymPol™ Transceivers												
SN65HVD96	SymPol Transceiver	1/1	Half	5	No	5	12	Short, Open, Idle	32	N	SOIC-8	1.20

*Suggested resale price in U.S. dollars in quantities of 1,000. See www.ti.com/hirel for HiRel options.

New products are listed in bold red. Preview products are listed in bold blue.

→ General – UARTs

Dual UART With 64-Byte FIFO

TL16C752C

Get samples and datasheets at: www.ti.com/sc/device/TL16C752C

Key Features

- ST16C654/654D pin-compatible with additional enhancements (PFB package only)
- Supports up to 24MHz crystal input clock (1.5Mbps)
- Supports up to 48MHz oscillator input clock (3Mbps) for 5V operation
- Supports up to 32MHz oscillator input clock (2Mbps) for 3.3V operation
- Supports up to 24MHz input clock (1.5Mbps) for 2.5V operation
- Supports up to 16MHz input clock (1Mbps) for 1.8V operation
- Programmable receive FIFO trigger levels for software/hardware flow control
- Software/hardware flow control
 - Programmable Xon/Xoff characters
 - Programmable auto-RTS and auto-CTS
- Characterized for operation from -40°C to $+85^{\circ}\text{C}$, available in commercial and industrial temperature grades

The TL16C752C is a dual universal asynchronous receiver/transmitter (UART) with 64-byte FIFOs, automatic hardware/software flow control and data rates up to 3Mbps. It incorporates the functionality of two UARTs, each UART having its own register set and FIFOs. The two UARTs share only the data bus interface and clock source; otherwise they operate independently. Another name for the UART function is asynchronous communications element (ACE), and these terms are used interchangeably. It has a transmission control register (TCR) that stores received FIFO threshold levels to start/stop transmission during hardware and software flow control.

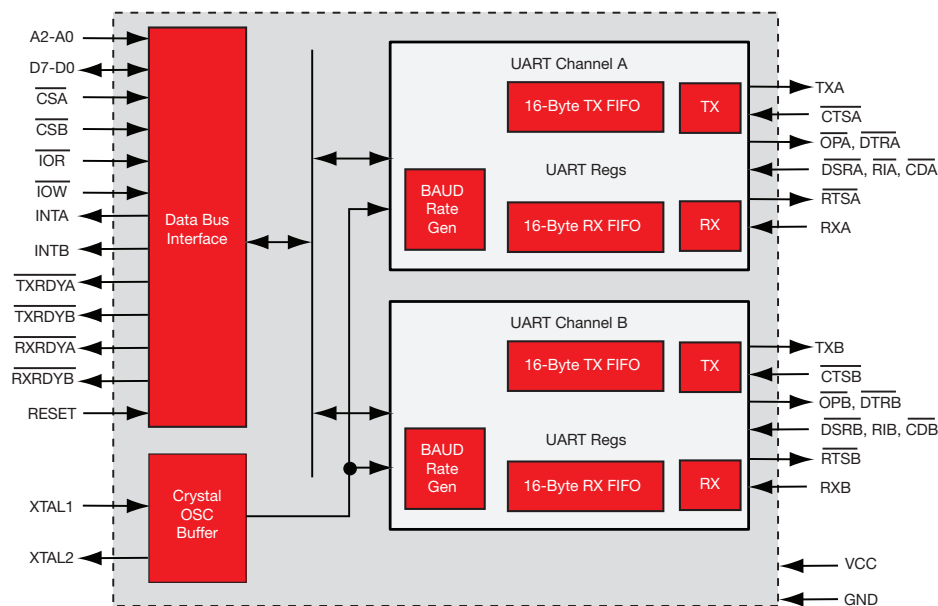

TL16C752C functional block diagram

→ General – UARTs

UARTs

Device	Description	Channel(s)	FIFOs	Voltage (V)	Characterized Temp. (°C)	HiRel Avail.	Package(s)	Price*
TL16C2550	Dual UART with Programmable Auto-RTS and Auto-CTS	2	16-Byte	1.8/2.5/3.3/5	–40 to 85	N	QFN-32, TQFP-48	2.20
TL16C2552	Dual UART with Programmable Auto-RTS and Auto-CTS	2	16-Byte	1.8/2.5/3.3/5	–40 to 85	N	PLCC-44	2.90
TL16C2752	Dual UART with Customizable Trigger Levels	2	64-Byte	1.8/2.5/3.3/5	–40 to 85	N	PLCC-44	3.50
TL16C450	Single UART	1	None	5	0 to 70	N	PLCC-44	1.50
TL16C451	Single UART with Parallel Port	1	None	5	0 to 70	N	PLCC-68	3.10
TL16C452	Dual UART with Parallel Port	2	None	5	0 to 70	N	PLCC-68	2.55
TL16C550C	Single UART with Hardware Autoflow Control	1	16-Byte	3.3/5	–40 to 85	N	PLCC-44, LQFP-48, TQFP-48	1.65
TL16C550D	Single UART with Hardware Autoflow Control	1	16-Byte	2.5/3.3/5	–40 to 85	N	QFN-32, LQFP-48, TQFP-48, BGA-24	1.30
TL16C552A	Dual UART with Parallel Port	2	16-Byte	5	–40 to 85	Y	PLCC-68, LQFP-80	3.60
TL16C554A	Quad UART with 16-Byte FIFO	4	16-Byte	3.3/5	–40 to 85	N	PLCC-68, LQFP-80, LQFP-64	5.50
TL16C750	Single UART with Hardware Autoflow Control, Low-Power Modes	1	64-Byte	3.3/5	–40 to 85	N	PLCC-44, LQFP-64	3.90
TL16C752B	Dual UART with Hardware Autoflow Control, Low-Power Modes	2	64-Byte	3.3	–40 to 85	Y	LQFP-48	2.60
TL16C754B	Quad UART with Hardware Autoflow Control, Low-Power Modes	4	64-Byte	3.3/5	–40 to 85	N	PLCC-68, LQFP-80	7.10
TL16C752C	Dual UART with Hardware Autoflow Control, Low-Power Modes	2	64-Byte	1.8/2.5/3.3/5	–40 to 85	N	QFN-32, TQFP-48	2.40
TL16C754C	Quad UART with Hardware Autoflow Control, Low-Power Modes	4	64-Byte	1.8/2.5/3.3/5	–40 to 85	N	LQFP-64	6.00
TL16PC564B/BLV	Single UART with PCMCIA Interface	1	64-Byte	3.3/5	0 to 70	N	LQFP-100	7.35
TL16PIR552	Dual UART with Dual IrDA and 1284 Parallel Port	2	16-Byte	5	0 to 70	N	QFP-80	7.65
TL28L92	Dual UART with X86 or 68K Interface	2	16-Byte	3.3/5	–40 to 85	N	QFP-44	6.00
Related Device								
TIR1000	Standalone IrDA Encoder and Decoder	—	—	2.7 to 5.5	–40 to 85	N	SO-8, TSSOP-8	1.15

*Suggested resale price in U.S. dollars in quantities of 1,000. See www.ti.com/hirel for HiRel options.

→ General – ESD/EMI

2-Channel ESD-Protection Array for AC-Coupled/Negative-Rail Data Interfaces

TPD2E007

Get samples and datasheets at: www.ti.com/sc/device/tpd2e007

Key Features

- ESD protection exceeds IEC61000-4-2 (level 4)
 - ±15kV human-body model (HBM)
 - ±8kV IEC 61000-4-2 contact discharge
 - ±15kV IEC 61000-4-2 air-gas discharge
- 4.5A peak pulse current (8/20ms Pulse)
- 15pF line to GND capacitance
- Low 50nA leakage current YFMG4
- 2-channel device
- Space-saving PicoStar™ and DCK package (0.8mm x 0.8mm [0.4mm pitch])

The TPD2E007 is designed to offer system-level ESD solutions for a wide range of portable and industrial applications. The back-to-back diode array allows AC-coupled or negative-going data transmission (audio interface, LVDS, RS-485, RS-232, etc.) without compromising signal integrity. The PicoStar™ package is intended to be embedded inside the printed circuit board, which saves board space in portable applications. This device exceeds IEC61000-4-2 (Level 4) ESD protection and is suitable to provide system-level ESD protection for the valuable internal ICs when placed near the connector.

The TPD2E007 is offered in 4-bump PicoStar and 3-pin DCK packages. The PicoStar package (YFMG4), with only 0.15mm (max) package height, is recommended for ultra-space saving applications where package height is a key concern. The PicoStar package can be used in either embedded PCB board applications or in surface-mount applications. The industry-standard DCK package offers a straightforward board layout option in legacy designs.

Applications

- Cell phones, PDAs
- Audio interface connections
- Consumer electronics (DVRs, set-top boxes, TVs)
- Industrial interfaces (RS-232, RS-485, RS-422, LVDS)

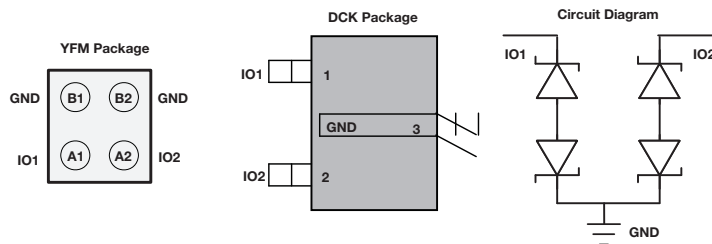

TPD2E007 package illustrations

HDMI Companion Chip with Step-Up DC/DC, I²C Level Shifter and High-Speed ESD Clamps

TPD12S015

Get samples and datasheets at: www.ti.com/sc/device/tpd12s015

Key Features

- HDMI 1.3 data rate
- HDMI high-speed differential signals – 3dB bandwidth exceeds 6.4Gbps
- Excellent matching capacitance (0.05pF) in each differential signal pair
- Internal boost converter to generate 5V from a 2.3- to 5.5V battery voltage
- Directionless level shifting in the CEC, SDA, SCL and HPD paths
- Seamless type C connector routing with flow-through pin mapping
- IEC 61000-4-2 (Level 4) system-level ESD
- Industrial temperature range: -40°C to +85°C

The TPD12S015 is an integrated HDMI ESD solution. The device pin mapping matches the HDMI type C/D connector with four differential pairs. This device offers eight low-capacitance ESD clamps, allowing HDMI 1.3 data rates. The integrated ESD clamps and resistors provide good matching between each differential signal pair, which allows an advantage over discrete ESD clamp solutions where variations between ESD clamps degrade the differential signal quality.

Applications

- Smart phones
- Multimedia phones
- Digital camcorders
- Digital still cameras
- Portable game consoles

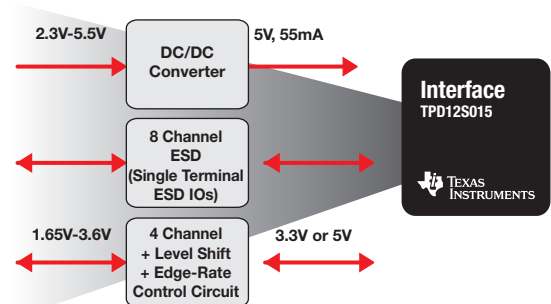

TPD12S015 illustration

 **General – ESD/EMI**
ESD/EMI

Device	Description	Number of Channels	I/O Capacitance (pF)	V _{BR} (min) (V)	HiRel Avail.	Package(s)	Price*
ESD Devices							
SN65220	USB 2.0 FS	2	35	7	Y	DSBGA-4, SOT-23-6	0.26
SN65240	USB 2.0 FS	4	35	7	N	PDIP-8, TSSOP-8	0.24
SN75240	USB 2.0 FS	4	35	7	N	PDIP-8, TSSOP-8	0.42
TPD4E002	USB 2.0 HS	4	11	6	N	SOT-5	0.14
TPD2E001	USB 2.0 HS	2	1.5	11	N	SOT-5, SON-6	0.15
TPD2E007	Audio, RS-232, RS-485, CAN	2	10	±14	N	DCK-3, DSLGA-4	0.20
TPD2E009	USB 2.0 FS, Ethernet, FireWire®, eSATA	2	0.7	7	N	SOT-23-3, SOT-3, SON-6	0.15
TPD2EUSB30	USB 3.0 SS, LVDS, eSATA	2	0.7	7	N	SOT-3	0.15
TPD2S017	USB 2.0 HS, FireWire, LVDS	2	1	11	N	SOT-6	0.14
TPD3E001	USB 2.0 HS, USB 2.0 OTG	3	1.5	11	N	SOT-5, SON-6	0.15
TPD4E001	USB 2.0 HS, Ethernet, FireWire, eSATA	4	1.5	11	N	SOT-6, SON-6	0.17
TPD4E002	Transient Overvoltage Protection	4	11	6.1	N	SOT-5	0.14
TPD4E004	USB 2.0 HS, Ethernet, FireWire, eSATA	4	1.6	6	N	SOT-6, SON-6	0.22
TPD4S009	eSATA, LVDS Signaling	4	0.8	9	N	SOT-23-6, SC70-6, SON-6	0.26
TPD4S010	eSATA, LVDS Signaling	4	0.8	9	N	SON-10	0.21
TPD4S012	USB 2.0 HS, Ethernet, FireWire, eSATA	4	0.8	6	N	SON-6	0.21
TPD4S1394	FireWire Live Insertion Protection	4	1.5	4.2	N	X2SON-8	0.23
TPD6E001	USB 2.0 HS, Ethernet, FireWire, eSATA	6	1.5	11	N	QFN-10, QFN-12	0.20
TPD6E004	USB 2.0 HS, Ethernet, FireWire, eSATA	6	1.6	6	N	QFN-8	0.27
TPD7S019	VGA, DVI-I	7	2.5	9	N	SSOP/QSOP-16	0.19
TPD8E003	LCD Display, Keypad, Memory	8	9	6	N	WSON-8	0.18
TPD8S009	HDMI, DisplayPort	8	0.9	9	N	SON-15	0.55
TPD12S520	HDMI	12	0.9	9	N	TSSOP-38	0.44
TPD12S521	HDMI	12	0.9	9	N	TSSOP-38	0.47
TPD12S015	HDMI	12	1.3	9	N	DSBGA-28	0.80
EMI Devices							
TPD2F702	Audio EMI Filter	2	1.2	±14	N	DSBGA-5	0.15
TPD4F003	LCD Display, Keypad, Memory	4	200	6	N	WSON-8	0.18
TPD4F202	LCD Display, Keypad, Memory	4	108	6	N	DSBGA-10	0.17
TPD6F002	LCD Display, Keypad, Memory	6	100	6	N	SON-12	0.21
TPD6F003	LCD Display, Keypad, Memory	6	200	6	N	WSON-12	0.21
TPD6F202	LCD Display, Keypad, Memory	6	108	6	N	DSBGA-15	0.21
TPD8F003	LCD Display, Keypad, Memory	8	200	6	N	SON-15	0.25
TPD8F303	SIM Card EMI Filter	3	20	6	N	WSON-8, SON-8	TBD

*Suggested resale price in U.S. dollars in quantities of 1,000. See www.ti.com/hirel for HiRel options.

Preview products are listed in **bold blue**.

Interface

→ General – I²C

Low-Voltage, 8-Bit I²C, SMBus I/O Expander with Interrupt Output, Reset and Configuration Registers TCA6408A

Get samples and datasheets at: www.ti.com/sc/device/TCA6408A

Key Features

- V_{CC} range of 1.65V to 5.5V on I²C and I/O side
- Bidirectional voltage-level translation and GPIO expansion between:
 - 1.8V SCL/SDA and 1.8V, 2.5V, 3.3V or 5V P Port
 - 2.5V SCL/SDA and 1.8V, 2.5V, 3.3V or 5V P Port
 - 3.3V SCL/SDA and 1.8V, 2.5V, 3.3V or 5V P Port
 - 5V SCL/SDA and 1.8V, 2.5V, 3.3V or 5V P Port
- 400KHz operation

Applications

- Housekeeping functions
 - Temperature, fan, audio control
 - Humidity sensors
 - LED status
 - Hardware control monitor
- Keypad control (up to 4x4 keypad or 16 buttons)

This 8-bit I/O expander for the two-line bidirectional bus (I²C) is designed to provide general-purpose remote I/O expansion for most microcontroller families via the I²C interface (serial clock [SCL] and serial data [SDA]).

The major benefit of this device is its wide V_{CC} range. It can operate from 1.65V to 5.5V on the P-port side and on the SDA/SCL side. This allows the TCA6408A to interface with next-generation microprocessors and microcontrollers on the SDA/SCL side, where supply levels are dropping down to conserve power. In contrast to the dropping power supplies of microprocessors and microcontrollers, some PCB components such as LEDs remain at a 5V power supply.

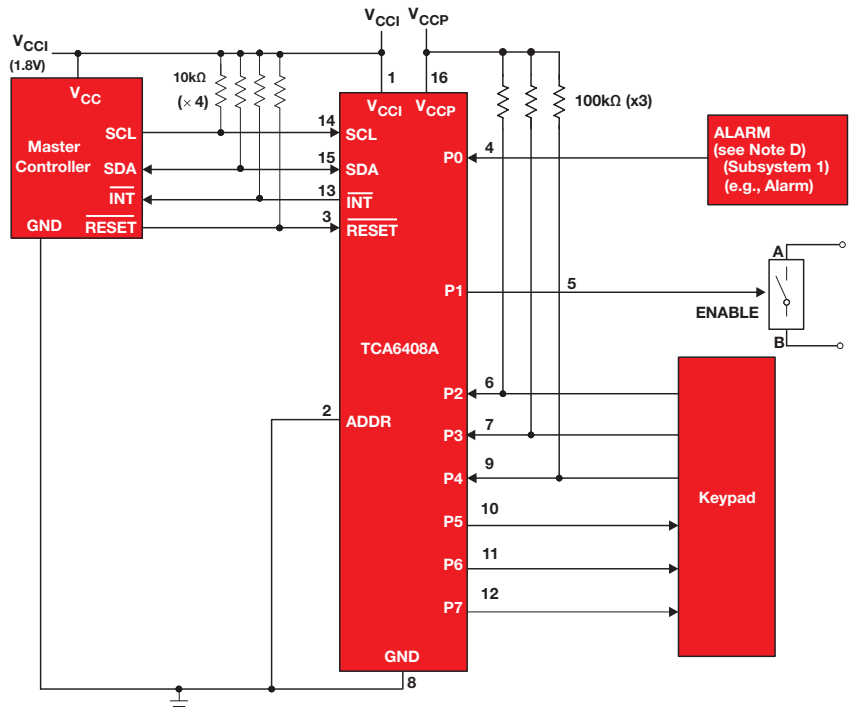

TCA6408 functional block diagram

→ General – I²C

Enhanced I²C Controlled Keypad Scan IC

TCA8418E

Get samples and datasheets at: www.ti.com/sc/device/TCA8418E

Key Features

- Operating power-supply voltage range of 1.65V to 3.6V
- Supports QWERTY keypad operation plus GPIO expansion
- 18 GPIOs can be configured into eight inputs and ten outputs to support an 8- to 10- keypad array (80 buttons)
- 15kV human body model ESD protection on GPIO lines
- Low standby (idle) current consumption: 3mA
- Polling current drain 70mA for one key pressed
- 10byte FIFO to store 10 key presses and releases
- Very small package: WCSP (YFP): 2mm x 2mm; 0.4mm pitch

Applications

- Smart phones
- PDAs
- GPS devices
- MP3 players
- Digital cameras

The TCA8418E is an enhanced keypad scan device. It can operate from 1.65V to 3.6V and has 18 general-purpose inputs/outputs (GPIO) that can be used to support up to 80 keys via the I²C interface [serial clock [SCL], serial data [SDA]].

The key controller includes an oscillator that debounces at 50ms and maintains a 10 byte FIFO of key-press and release events that can store up to 10 keys with overflow wrap capability. An interrupt (INT) output can be configured to alert key presses and releases either as they occur or at maximum rate. Also, for the YFP package, a CAD_INT pin is included to indicate the detection of CTRL-ALT-DEL (i.e., 1, 11, 21) key-press action.

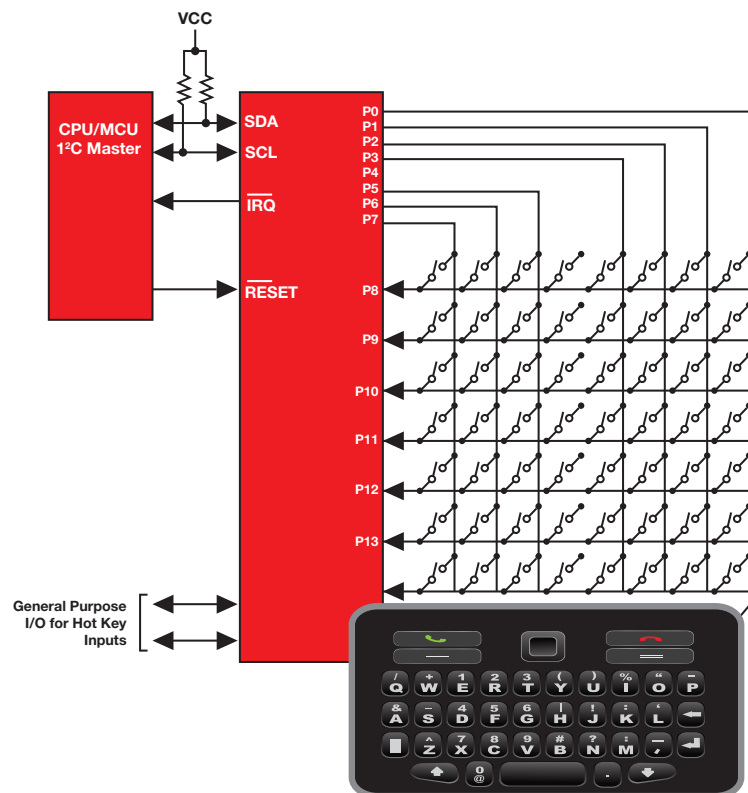

TCA8418E functional block diagram

 **General – I²C**
I²C

Buffer/Repeaters						
Device	Description	No. of Outputs	f _{SCLK} (max) (kHz)	HiRel Avail.	Package(s)	Price*
P82B715	I ² C Bus [®] Extender	2	400	N	PDIP-8, SOIC-8	1.60
P82B96	Dual Bidirectional Bus Buffer	2	400	N	MSOP-8, PDIP-8, SOIC-8, TSSOP-8	1.60
PCA9515A	Dual Bidirectional I ² C Bus and SMBus Repeater	2	400	N	MSOP-8, PDIP-8, SOIC-8, SON-8, TSSOP-8	0.95
PCA9517	Level-Translating I ² C Bus Repeater	2	400	N	MSOP-8, SOIC-8	1.05
PCA9518	Expandable Five-Channel I ² C Hub	5	400	N	SOIC-20, SSOP-20, SSOP-20/QSOP, TSSOP-20	0.85
TCA4311	Hot Swappable 2-Wire Bus Buffers	2	400	N	MSOP-8, SOIC-8	1.45
I/O Expanders						
Device	Description	I/O Bits	f _{SCLK} (max) (kHz)	HiRel Avail.	Package(s)	Price*
PCA6107	Remote 8-Bit I ² C and SMBus Low-Power I/O Expander with Interrupt Output, Reset and Configuration Registers	8	400	N	SOIC-8	1.05
PCA9534A	Remote 8-Bit I ² C and Low-Power I/O Expander with Interrupt Output and Configuration Registers	8	400	N	QFN-16, SOIC-16, SSOP-16, SSOP-16/QSOP, TSSOP-16, TVSOP-16	0.75
PCA9536	Remote 4-Bit I ² C and SMBus I/O Expander with Configuration Registers	4	400	N	DSBGA-8, MSOP-8, SOIC-8	0.60
PCA9538	Remote 8-Bit I ² C and SMBus Low-Power I/O Expander with Interrupt Output, Reset and Configuration Registers	8	400	N	SOIC-16, SSOP-16, TSSOP-16, TVSOP-16	1.00
PCA9554A	Remote 8-Bit I ² C and SMBus I/O Expander with Interrupt Output and Configuration Registers	8	400	N	QFN-16, SOIC-16, SSOP-16, SSOP-16/QSOP, TSSOP-16, TVSOP-16	0.85
PCA9557	Remote 8-Bit I ² C and SMBus Low-Power I/O Expander with Reset and Configuration Registers	8	400	N	QFN-16, SOIC-16, SSOP-16, TSSOP-16, TVSOP-16	0.90
PCF8574A	Remote 8-Bit I/O Expander for I ² C Bus	8	400	N	PDIP-16, SOIC-16, QFN-20, TSSOP-20, TVSOP-20	1.00
PCF8575	Remote 16-Bit I ² C and SMBus I/O Expander with Interrupt Output	16	400	N	QFN-24, SOIC-24, SSOP-24, SSOP-24/QSOP, TSSOP-24, TVSOP-24, VQFN-24	1.45
PCF8575C	Remote 16-Bit I ² C and SMBus I/O Expander with Interrupt Output	16	400	N	SOIC-24, SSOP-24, SSOP-24/QSOP, TSSOP-24, TVSOP-24, VQFN-24	1.45
TCA6408A	Low-Voltage 8-Bit I ² C and SMBus I/O Expander with Interrupt Output, Reset and Configuration Register	8	400	N	QFN-16, TSSOP-16, BGA-20 MicroStar Junior™	0.75
TCA6416A	Low-Voltage 16-Bit I ² C and SMBus I/O Expander with Interrupt Output, Reset and Configuration Registers	16	400	N	24-BGA MicroStar Junior, QFN-24, TSSOP-24	0.85
TCA6424A	Low-Voltage 24-Bit I ² C and SMBus I/O Expander with Interrupt Output, Reset and Configuration Registers	24	400	N	QFN-32	0.95
TCA6507	Low-Voltage 7-Bit I ² C and SMBus LED Driver with Intensity Control and Shutdown	7	400	N	BGA-12 MicroStar Junior, QFN-12, TSSOP-14	0.75
TCA9535	Remote 16-Bit I ² C and SMBus, Low-Power I/O Expander with Interrupt Output and Configuration Registers	16	400	N	QFN-24, TSSOP-24	1.00
TCA9539	Remote 16-Bit I ² C And SMBus, Low-Power I/O Expander with Interrupt Output, Reset and Configuration Registers	16	400	N	QFN-24, TSSOP-24	1.10
TCA9555	Remote 16-Bit I ² C And SMBus I/O Expander with Interrupt Output and Configuration Registers	16	400	N	QFN-24, TSSOP-24	1.20
TCA8418	I ² C Controlled Keypad Scan IC	18	400	N	QFN-24	1.20
TCA8418E	I ² C Controlled Keypad Scan IC with Integrated ESD	18	400	N	DSBGA-25	1.20
Switches/Multiplexers						
Device	Description	tpd (max) (ns)	f _{SCLK} (max) (kHz)	HiRel Avail.	Package(s)	Price*
PCA9543A	Two-Channel I ² C Bus Switch with Interrupt Logic and Reset	0.3, 1	400	N	SOIC-14, TSSOP-14	0.80
PCA9544A	4-Channel I ² C and SMBus Multiplexer with Interrupt Logic	0.3, 1	400	N	BGA-20 MicroStar Junior, QFN-20, SOIC-20, TSSOP-20, TVSOP-20	0.95
PCA9545A	4-Channel I ² C and SMBus Multiplexer with Interrupt Logic and Reset Functions	0.3, 1	400	N	BGA-20 MicroStar Junior, QFN-20, SOIC-20, TSSOP-20, TVSOP-20	0.95
PCA9546A	4-Channel I ² C and SMBus Multiplexer with Reset Functions	0.3, 1	400	N	QFN-16, SOIC-16, TSSOP-16, TVSOP-16, BGA-20 Microstar Junior, TVSOP-20	0.85
PCA9548A	8-Channel I ² C Switch with Reset	0.3, 1	400	N	SOIC-24, SSOP-24, TSSOP-24, TVSOP-24, VQFN-24	1.15
Translator						
PCA9306	Dual Bidirectional I ² C Bus and SMBus Voltage-Level Translator	1.5	400	Y	8-SM8, 8-US8	0.26
TCA9406	Dual Bidirectional I ² C Bus and SMBus Voltage-Level Translator	1.1	1,000	N	8-SSOP, 8-USSOP, 8-WCSP	TBD

*Suggested resale price in U.S. dollars in quantities of 1,000. See www.ti.com/hirel for HiRel options.

Preview products are listed in **bold blue**.

 **General – RS-232**
RS-232

Device	Data Rate (kbps)	Drivers	Receivers	ESD HBM (kV)	Supply Voltage(s) (V)	I _{cc} (max) (mA)	HiRel Avail.	Package(s)	Price*
TRS202E	120	2	2	IEC61000-4-2	5	15	N	PDIP-16, SOIC-16, TSSOP-16	0.54
TRS207	120	5	3	±15	5	20	N	SOIC-24, SSOP-24	1.08
TRS208	120	4	4	±15	5	20	N	SOIC-24, SSOP-24	1.08
TRS211	120	4	5	±15	5	20	N	SOIC-28, SSOP-28	1.08
TRS213	120	4	5	15	5	20	N	SOIC-28, SSOP-28	1.08
TRS222	200	2	2	±15	5	10	N	PDIP-18, SOIC-18	1.26
TRS232E	250	2	2	IEC61000-4-2	5	10	N	PDIP-16, SOIC-16, TSSOP-16	0.58
TRS3221E	250	1	1	IEC61000-4-2	5	1	N	SSOP-16, TSSOP-16	0.88
TRS3222E	250	2	2	IEC61000-4-2	5	1	N	SOIC-20, SSOP-20, TSSOP-20	1.28
TRS3223E	250	3	3	IEC61000-4-2	5	1	Y	SOIC-20, SSOP-20, TSSOP-20	1.12
TRS3227E	1000	1	1	IEC61000-4-2	5	1	N	SSOP-16	1.20
TRS3232E	250	2	2	IEC61000-4-2	5	0.3	Y	SOIC-16, SSOP-16, TSSOP-16	0.96
TRS3237E	1000	5	3	IEC61000-4-2	5	1	N	SOIC-28, SSOP-28, TSSOP-28	1.33
TRS3238E	250	5	3	IEC61000-4-2	5	1	N	SOIC-28, SSOP-28, TSSOP-28	1.20
TRS3243E	500	3	5	IEC61000-4-2	5	1	N	SOIC-28, SSOP-28, TSSOP-28, QFN-32	0.88
TRS3253E	1000	3	5	IEC61000-4-2	3.3 or 5	1	N	QFN-32	CALL
TRS3318E	460	2	2	IEC61000-4-2	5	1	N	SSOP-20, TSSOP-20	1.68
TRS3386E	250	3	2	IEC61000-4-2	5	1	N	SOIC-20, TSSOP-20	1.92
TRSF23243	250	3	5	±15	5	1	N	SSOP-48, TSSOP-48	3.42
TRSF3221E	1000	1	1	IEC61000-4-2	5	1	N	SSOP-16, TSSOP-16	1.26
TRSF3222E	1000	2	2	IEC61000-4-2	5	1	N	SOIC-20, SSOP-20, TSSOP-20	1.44
TRSF3223E	1000	2	2	IEC61000-4-2	5	1	N	SOIC-20, SSOP-20, TSSOP-20	1.44
TRSF3232	1000	2	2	±15	5	1	N	SOIC-16, SSOP-16, TSSOP-16	1.26
TRSF3238E	1000	5	3	IEC61000-4-2	5	2	N	SOIC-28, SSOP-28	1.62
TRSF3243	1000	3	5	±15	5	1	N	SOIC-28, SSOP-28, TSSOP-28	1.62
TRSF3253	1000	3	5	±15	5	1	N	SOIC-28, SSOP-28, TSSOP-28	1.62
GD65232	120	3	5	—	±9, 5	38	N	PDIP-20, SOIC-20, SSOP-20, TSSOP-20	0.29
GD75232	120	3	5	—	±9, 5	30	N	PDIP-20, SOIC-20, SSOP-20, TSSOP-20	0.27
GD75323	120	5	3	—	±12, 5	32	N	SOIC-20	0.41
LT1030	120	4	—	—	±5	1	N	PDIP-14, SOIC-14	1.44
SN65C1406	120	3	3	—	±12, 5	0.45	N	SOIC-16	1.80
SN75154	120	4	4	—	5 or 12	35	N	PDIP-16, SOIC-16	0.72
SN75155	120	1	1	2	±12	14	N	PDIP-8, SOIC-8	0.72
SN751701	120	1	1	—	±5, 9, 12	11.9	N	SOIC-8	1.30
SN75185	120	3	5	10	±12, 5	30	N	PDIP-20, SOIC-20, SSOP-20, TSSOP-20	0.45
SN75186	120	1	1	—	±12, 5	10	N	SOIC-24	1.80
SN75188	120	4	—	2	±9	25	N	PDIP-14, SOIC-14	0.22
SN75189A	120	—	4	—	5	26	N	PDIP-14, SOIC-14	0.22
SN75196	120	5	3	10	±12, 5	20	N	PDIP-20, SOIC-20	0.68
SN752232	120	6	10	—	5	±50	N	SSOP-48, TSSOP-48	0.90
SN75C1406	120	3	3	2	±12, 5	0.45	N	PDIP-16, SOIC-16	0.86
SN75C185	120	3	5	2	±12, 5	0.75	N	PDIP-20, SOIC-20	1.08
SN75C188	120	4	—	2	±12	0.16	N	PDIP-14, SOIC-14, SSOP-14	0.31
SN75C189A	120	—	4	—	5	0.7	N	PDIP-14, SOIC-14, SSOP-14	0.31
SN75C23243	250	6	10	15	3.3 or 5	0.02	N	SSOP-48, TSSOP-48	3.42
SN75LBC187	120	3	5	—	5	30	N	SSOP-28	3.60
SN75LBC241	100	4	5	—	5	8	N	SOIC-28	2.16
SN75LP1185	256	3	5	15	5, ±12	1	N	PDIP-20, SOIC-20, SSOP-20	1.78
SN75LP196	256	5	3	15	5, ±12	1	N	PDIP-20, SOIC-20, SSOP-20, TSSOP-20	1.78
SN75LPE185	256	3	5	15	5, ±12	1	N	PDIP-24, SOIC-24, SSOP-24, TSSOP-24	1.89
SN75LV4737A	128	3	5	4	3 or 5	20.7	N	SSOP-28	2.61
TL145406	120	3	3	2	±12, 5	20	N	PDIP-16, SOIC-16	0.94
UA9636A	120	2	—	—	±12	36	N	PDIP-8, SOIC-8	0.36
UC5170C	120	—	—	—	—	—	Y	PLCC-28	3.15
UC5180C	120	—	8	—	4.75 to 5.25	35	N	PLCC-28	3.00
UC5181C	120	—	8	—	4.75 to 5.25	35	N	PLCC-28	3.15

*Suggested resale price in U.S. dollars in quantities of 1,000. See www.ti.com/hirel for HiRel options.

→ General – Voltage-Level Translators

Single-Supply Translators

Device	Bits	Trans Low (V)	Trans High (V)	V _{CC} (V)	DIR Pins	Bus Hold	OE Pins	t _{pd} (max) (ns)	HiRel Avail.	Price*
SN74AUP1T57	3	2.5	3.3	2.3 to 3.6	No	No	No	6.2	N	0.24
SN74AUP1T58	3	2.5	3.3	2.3 to 3.6	No	No	No	6.2	N	0.24
SN74AUP1T97	3	2.5	3.3	2.3 to 3.6	No	No	No	6.2	N	0.24
SN74AUP1T98	3	2.5	3.3	2.3 to 3.6	No	No	No	6.2	N	0.40

Dual-Supply Translators

Device	Bits	Trans Low (V)	Trans High (V)	V _{CC} A (V)	V _{CC} B (V)	DIR Pins	Bus Hold	OE Pins	t _{pd} (max) (ns)	HiRel Avail.	Price*
TXB0101	1	1.2	5	1.2 to 3.6	1.65 to 5.5	Auto	No	1	4.5	N	0.44
TXB0102	2	1.2	5	1.2 to 3.6	1.65 to 5.5	Auto	No	1	4.5	N	0.39
TXB0104	4	1.2	5	1.2 to 3.6	1.65 to 5.5	Auto	No	1	4	Y	0.55
TXB0104-Q1	4	1.2	5	1.2 to 3.6	1.65 to 5.5	Auto	No	1	7	N	0.65
TXB0106	6	1.2	5	1.2 to 3.6	1.65 to 5.5	Auto	No	1	4	Y	0.70
TXB0108	8	1.2	5	1.2 to 3.6	1.65 to 5.5	Auto	No	1	4	N	0.80
TXS0101	1	1.8	5	1.65 to 3.6	2.3 to 5.5	Auto	No	1	7.5	N	0.44
TXS0102	2	1.8	5	1.65 to 3.6	2.3 to 5.5	Auto	No	1	4.6	N	0.33
TXS0104E	4	1.8	5	1.65 to 3.6	2.3 to 5.5	Auto	No	1	4.6	N	0.65
TXS0108E	8	1.2	5	1.2 to 3.6	1.65 to 5.5	Auto	No	1	4.8	N	0.80
SN74AVC1T45	1	1.2	3.3	1.2 to 3.6	1.2 to 3.6	1	No	No	2.8	N	0.31
SN74AVC2T45	2	1.2	3.3	1.2 to 3.6	1.2 to 3.6	1	No	No	2.4	Y	0.42
SN74AVCH1T45	1	1.2	3.3	1.2 to 3.6	1.2 to 3.6	1	Yes	No	2.8	N	0.31
SN74AVCH2T45	2	1.2	3.3	1.2 to 3.6	1.2 to 3.6	1	Yes	No	2.4	N	0.40
SN74AVC2T245	2	1.2	3.3	1.2 to 3.6	1.2 to 3.6	2	No	1	2.4	N	0.46
SN74AVC4T245	4	1.2	3.3	1.2 to 3.6	1.2 to 3.6	2	No	2	2.9	Y	0.65
SN74AVC8T245	8	1.2	3.3	1.2 to 3.6	1.2 to 3.6	1	No	1	2.5	Y	0.55
SN74AVC16T245	16	1.2	3.3	1.2 to 3.6	1.2 to 3.6	2	No	2	2.7	Y	1.50
SN74AVC20T245	20	1.2	3.3	1.2 to 3.6	1.2 to 3.6	2	No	2	2.9	N	1.60
SN74AVC24T245	24	1.2	3.3	1.2 to 3.6	1.2 to 3.6	6	No	6	2.7	N	1.75
SN74AVC32T245	32	1.2	3.3	1.2 to 3.6	1.2 to 3.6	4	No	4	2.7	N	1.80
SN74AVCH4T245	4	1.2	3.3	1.2 to 3.6	1.2 to 3.6	2	Yes	2	2.9	Y	0.70
SN74AVCH8T245	8	1.2	3.3	1.2 to 3.6	1.2 to 3.6	1	Yes	1	2.5	N	1.10
SN74AVCH16T245	16	1.2	3.3	1.2 to 3.6	1.2 to 3.6	2	Yes	2	2.7	N	1.50
SN74AVCH20T245	20	1.2	3.3	1.2 to 3.6	1.2 to 3.6	2	Yes	2	2.9	N	1.60
SN74AVCH24T245	24	1.2	3.3	1.2 to 3.6	1.2 to 3.6	6	Yes	6	2.7	N	1.75
SN74AVCH32T245	32	1.2	3.3	1.2 to 3.6	1.2 to 3.6	4	Yes	4	2.7	N	4.00
SN74AVC4T774	4	1.2	3.3	1.2 to 3.6	1.2 to 3.6	4	No	1	2.4	N	0.70
SN74LVC1T45	1	1.8	5	1.65 to 5.5	1.65 to 5.5	1	No	No	3.9	N	0.29
SN74LVC2T45	2	1.8	5	1.65 to 5.5	1.65 to 5.5	1	No	No	3.9	N	0.40
SN74LVC8T245	8	1.8	5	1.65 to 5.5	1.65 to 5.5	1	No	1	4.2	N	0.80
SN74LVCH8T245	8	1.8	5	1.65 to 5.5	1.65 to 5.5	1	Yes	1	4.2	N	0.80
SN74LVC16T245	16	1.8	5	1.65 to 5.5	1.65 to 5.5	2	No	2	4.2	N	1.65
SN74LVCH16T245	16	1.8	5	1.65 to 5.5	1.65 to 5.5	2	Yes	2	4.2	N	1.65

*Suggested resale price in U.S. dollars in quantities of 1,000. See www.ti.com/hirel for HiRel options.

→ Broadband RF

High-Linearity Direct-Conversion Quadrature Demodulator

TRF371125

NEW

Get samples, datasheets and evaluation modules at: www.ti.com/sc/device/TRF371125

Key Features

- Frequency range: 0.7 to 4.0GHz
- Noise figure of 13.5dB (gain = 40dB)
- IIP3 of 24dBm (gain = 40dB)
- IIP2 of 60dBm (gain = 40dB)
- Baseband PGA with 24dB of gain range in 1dB steps
- Software-programmable baseband filter (1dB corner)
- Receives RF signal bandwidths from 1.4MHz to 30MHz
- Integrated ADC driver
- DC offset correction capability

Applications

- Cellular basestation receivers
- Software-defined radios (SDRs)
- Test equipment
- Wireless local loops
- High-linearity direct down-conversion receivers

The TRF371125 is a highly linear and integrated direct-conversion quadrature demodulator optimized for 3G/4G wireless infrastructure equipment. The TRF371125 integrates balanced I and Q mixers, LO buffers and phase splitters to convert an RF signal directly to I and Q baseband. The on-chip programmable gain amplifiers (PGAs) allow adjustment of the output signal level without the need for external variable gain (attenuator) devices. The TRF371125 integrates programmable baseband low-pass filters that attenuate nearby interference, eliminating the need for an external baseband filter. Housed in a 7mm x 7mm QFN package, the TRF371125 provides the smallest and most integrated receiver solution available for high-performance equipment.

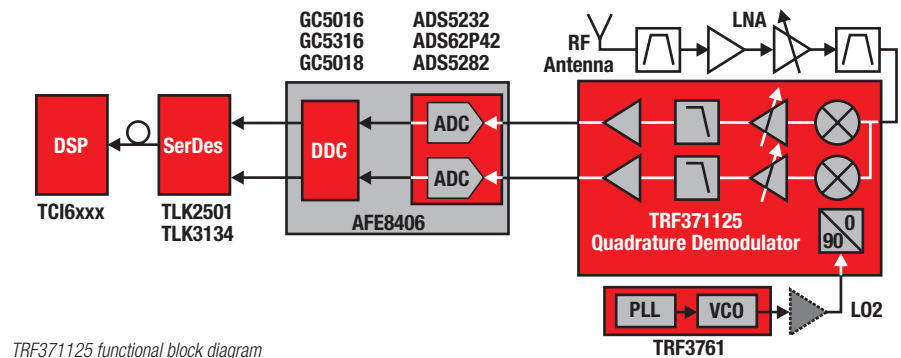

TRF371125 functional block diagram

Integrated IQ Modulator PLL/VCO

TRF372017

Get samples, datasheets and evaluation modules at: www.ti.com/sc/device/TRF372017

Key Features

- Fully integrated PLL/VCO and IQ modulator
- LO frequency from 300MHz to 4.8GHz
- 76dBc single-carrier WCDMA ACPR at -8dBm channel power
- OIP3 of 26dBm
- P1dB of 11.5dBm
- Integer/fractional PLL
- Phase noise -132dBc/Hz
- Low noise floor: -160dBm/Hz
- Input reference frequency range: up to 160MHz

Applications

- Wireless infrastructure
 - CDMA: IS95, UMTS, CDMA2000, TD-SCDMA
 - TDMA: GSM, IS-136, EDGE/UWC-136
 - LTE
- Wireless local loop
- Point-to-point wireless access
- Wireless MAN wideband transceivers

The TRF372017 is a high performance direct up-conversion device, integrating a high linearity, low noise IQ modulator and an integer-fractional PLL/VCO. The VCO uses integrated frequency dividers to achieve a wide, continuous tuning range of 300MHz-4800MHz. The LO is available as an output with independent frequency dividers. The device also accepts input from an external LO or VCO. The modulator baseband inputs can be biased either internally or externally. Internal DC offset adjustment enables carrier cancellation. The device is controlled through a 3 wire serial programming interface (SPI™). A control pin invokes power-save mode to reduce power consumption while keeping the VCO locked for fast startup.

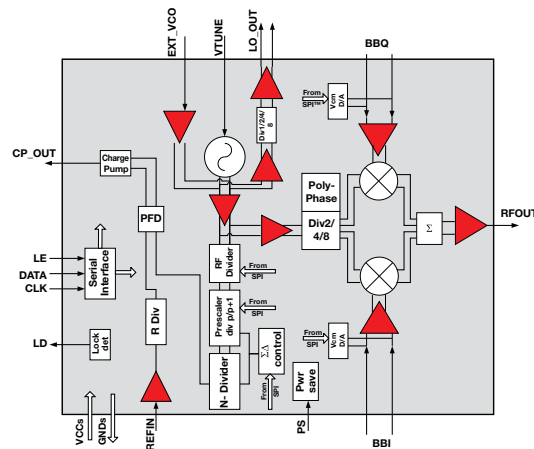

TRF372017 functional block diagram

→ Broadband RF

High-Performance Quadrature Modulators

Device	Frequency (min) (MHz)	Frequency (max) (MHz)	OIP3 (dBm)	P1dB (dBm)	Noise Floor (dBm/Hz)	I/Q Common-Mode Voltage (typ) (V)	HiRel Available	Price*
TRF370315	350	4000	23	9.5	-160	1.5	N	4.95
TRF370317	400	4000	26.5	12	-163	1.7	N	5.35
TRF370333	350	4000	21	9.5	-160	3.3	N	4.95
TRF370417	50	6000	26.5	12	-163	1.7	N	5.35

Integrated Quadrature Modulator

Device	Frequency (min) (MHz)	Frequency (max) (MHz)	OIP3 (dBm)	P1dB (dBm)	Noise Floor (dBm/Hz)	LO Phase Noise (1MHz Offset, 2.3GHz) (dBc/Hz)	I/Q Common-Mode Voltage (typ) (V)	HiRel Available	Price*
TRF372017	300	4800	26	12	-163	-132	1.7	N	5.50

Integrated Quadrature Demodulators

Device	Frequency Range (Optimized) (GHz)	BB Filter Bandwidth (min) (MHz)	BB Filter Bandwidth (max) (MHz)	IIP2 (typ) (dBm)	IIP3 (typ) (dBm)	HiRel Available	Price*
TRF3710	1.7 to 2.0	0.615	1.92	60	21	N	10.45
TRF371109	0.7 to 1.0	0.700	15.0	60	24	N	11.15
TRF371125	1.7 to 2.7	0.700	15.0	60	24	N	11.15
TRF371135	3.3 to 3.8	0.700	15.0	60	24	N	11.15

High-Performance IF Transceiver

Device	Tx LO Frequency (min) (MHz)	Tx LO Frequency (max) (MHz)	Tx Output Noise Floor (dB)	Tx Output IP3 (dBm)	Rx LO Frequency (min) (MHz)	Rx LO Frequency (max) (MHz)	Rx Noise Figure (dB)	Rx Input IP3 (dBm)	Rx BB Filter Cutoff (min) (MHz)	Rx BB Filter Cutoff (max) (MHz)	Rx BB Max Passband (typ) (MHz)	HiRel Avail.	Price*
TRF2443	165	350	-166	29.5	140	330	4.3	9.5	2	11	30	N	24.00

High-Performance Frequency Synthesizers

Device	Divide by 1		Divide by 2		Divide by 4		HiRel Available	Price*
	Fstart	Fstop	Fstart	Fstop	Fstart	Fstop		
TRF3761-A	1499	1608	749.5	804	374.75	402	N	5.45
TRF3761-B	1595	1711	797.5	855.5	398.75	427.75	N	5.45
TRF3761-C	1660	1790	830	895	415	447.5	N	5.45
TRF3761-D	1740	1866	870	933	435	466.5	N	5.45
TRF3761-E	1805	1936	902.5	968	451.25	484	N	5.45
TRF3761-F	1850	1984	925	992	462.5	496	N	5.45
TRF3761-G	1920	2059	960	1029.5	480	514.75	N	5.45
TRF3761-H	2028	2175	1014	1087.5	507	543.75	N	5.45
TRF3761-J	2140	2295	1070	1147.5	535	573.75	N	5.45

*Suggested resale price in U.S. dollars in quantities of 1,000.

New products are listed in bold red. Preview products are listed in bold blue.

→ Wireless Connectivity

ZigBee® RF4CE System-on-Chip CC2533

Get samples, datasheets and app reports at: www.ti.com/sc/device/CC2533

Key Features

- Up to 96kB flash with 20K erase cycles to support over-the-air updates, large applications
- Up to 6kB RAM for complex remote control applications
- Less than 1µA current consumption in power down with sleep timer running
- UART, I²C and SPI™ interfaces
- IR generation and modulation engine

Applications

- Remote controls
- Set-up boxes, TVs, Blu-ray™ players
- 3D glasses
- Smart energy

The CC2533 is a cost-effective, low power, and true system-on-chip solution specifically tailored to IEEE 802.15.4 / RF4CE applications. The CC2533 comes in three different versions: CC2533-F32/64 with 32/64KB flash memory and 4KB of RAM and the CC2533-F96 with 96KB Flash and 6KB of RAM. The CC2533 combines a fully integrated high-performance RF transceiver with an industry-standard enhanced 8051 MCU and powerful supporting features and peripherals.

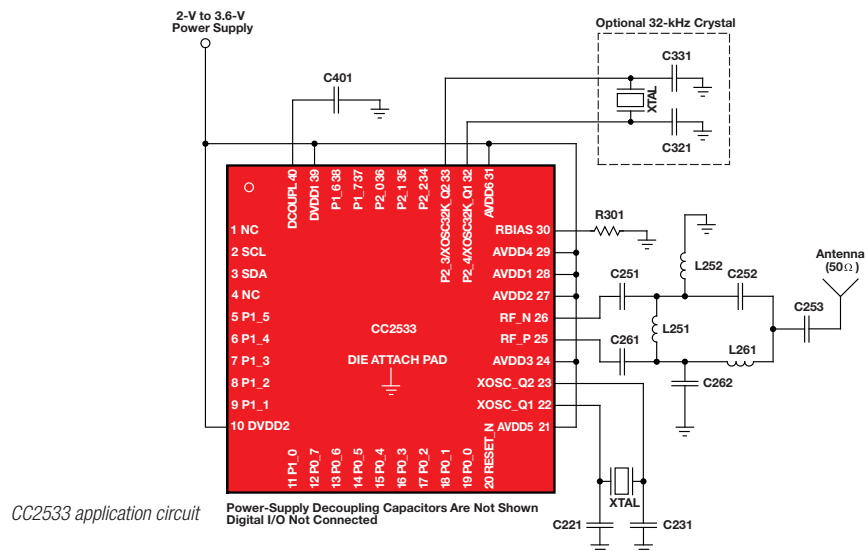

Single-Mode Bluetooth® Low Energy System-On-Chip CC2540

Get samples, datasheets and app reports at: www.ti.com/sc/device/CC2540

Key Features

- True one-chip single-mode Bluetooth® low energy solution
- Optimized RF performance including Tx/Rx power and selectivity
- Extensive peripheral set including USB, DMA, GPIO, USARTs, ADC, timers
- Flexible low power modes to maximize system lifetime when battery powered

Applications

- Mobile/laptop accessories
- Sports and fitness
- Consumer health and medical
- Proximity

The CC2540 is a cost-effective, low power, true System-on-Chip (SoC) solution for single-mode Bluetooth® low energy applications, including mobile accessories, sports and fitness, consumer health, sensors and actuators, remote controls, HID, proximity, and more. The CC2540 combines a 1Mbps GFSK RF transceiver, offering superior range over the competition with a peripheral rich 8051 MCU core. This highly integrated and low cost SoC, coupled with TI's Bluetooth low energy stack, offers a true one-chip integrated solution.

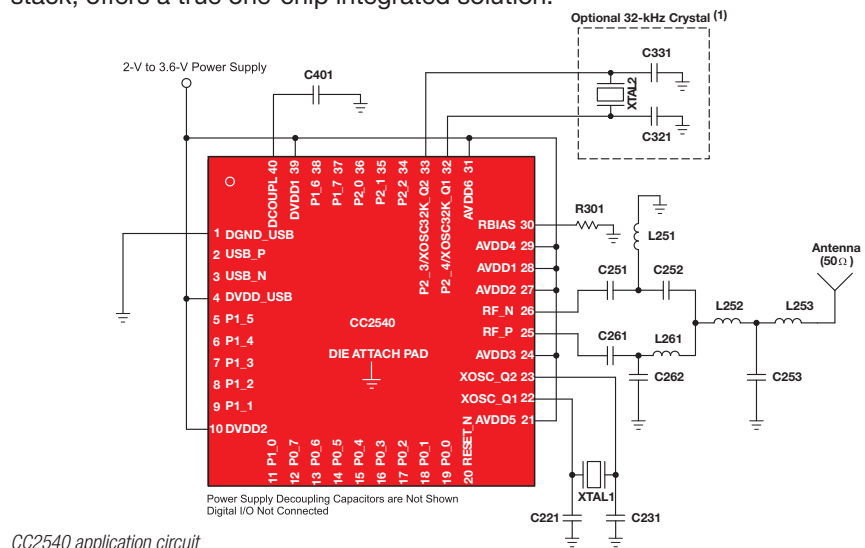

→ Wireless Connectivity

Bluetooth® v2.1 + EDR (Enhanced Data Rate) Transceiver

CC2560-PAN1325

NEW

Get samples, datasheets and app reports at: www.ti.com/cc2560-pan1325

Key Features

- Fully qualified Bluetooth® v2.1 + EDR (enhanced data rate)
- +10dBm Tx power with transmit power control
- -93dBm receiver sensitivity
- Support for Bluetooth power saving modes
- Integrated antenna (PAN1315 available without antenna)
- HW and SW pre-integration with TI's MSP430™ and Stellaris® platforms
- Bluetooth, FCC, CE, IC certified
- Dimensions: 9 mm x 9.5 mm x 1.8 mm
- Bluetooth + ANT®, and Bluetooth + BLE footprint-compatible modules available in 1H11 and 2H11 respectively

Applications

- Cable replacement
- Wireless sensors
- Medical devices
- Computer peripherals
- Industrial control
- Consumer devices

The CC2560-PAN1325 is a highly-integrated class 2 HCI module with increased output power capabilities offered by Panasonic utilizing TI's CC2560 Bluetooth® 2.1 + EDR Transceiver. Based on TI's 7th generation Bluetooth technology, the solution provides best-in-class Bluetooth RF performance of +10dBm Tx power and -93 dBm receiver sensitivity. This solution is provided as a module to help customers reduce development time, lower manufacturing costs, save board space, ease certification, and minimize RF expertise required. For evaluation and development, various platforms are available which integrate the Panasonic module, Bluetooth stack, Profiles (SPP for MSP430™, SPP + A2DP for Stellaris®), and sample source applications running on a TI host controller (MSP430, Stellaris).

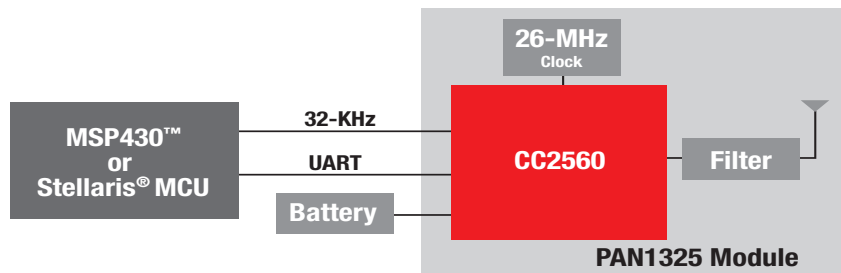

CC2560-PAN1325 Bluetooth® system

CC2560-PAN1325 system block diagram

PurePath™ Wireless™ 2.4GHz RF System-on-Chip For Wireless Digital Audio Streaming

CC8520

Get samples, datasheets and app reports at: www.ti.com/sc/device/CC8520

Key Features

- Embedded audio network protocol with state-of-the art error correction and concealment techniques
- Uncompressed wireless 44.1/48kHz stereo audio
- Autonomous operation
- UART, I²C and SPI™ interfaces
- Free PurePath™ Wireless™ configurator PC tool

Applications

- Wireless headphones / headsets
- Wireless speaker systems
- Wireless signal cable replacement
- Wireless home theatre systems

The CC8520 is used to build a lossless wireless audio link. One CC8520 acts as audio source and the other as audio sink. I²S data is taken as input on the audio source side, audio data is transmitted without loss to the audio sink which then outputs the I²S audio data.

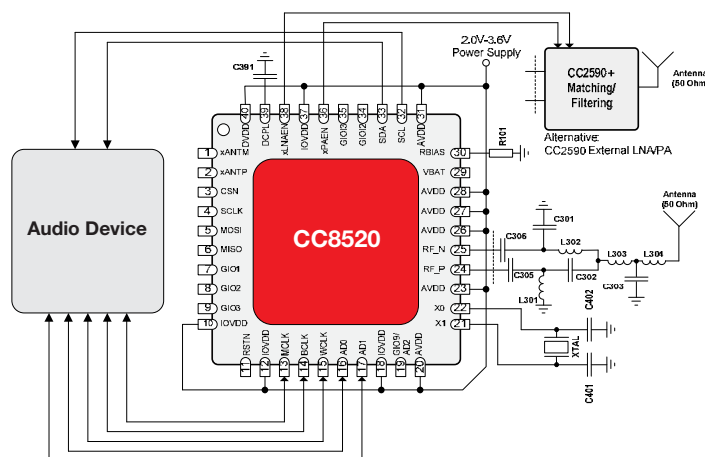

CC8520 application circuit

→ Wireless Connectivity

1- and 8-Channel ANT[®] RF Network Processors

CC2570/CC2571

Get samples, datasheets and app reports at: www.ti.com/sc/device/CC2570

Key Features

- ANT[®] compliant RF network processors
- UART/SPI[™] serial interface to easy-to-use API command set
- Excellent RF performance (avg. power and boosted output power)
- Accurate full-range RSSI function suited for proximity
- ANT-FS support

Benefits

- Easy-to-integrate into ANT products
- Simple, accessible serial interface to ANT enable your product
- Optimized low power for long device lifetime
- High resolution RSSI proximity pairing

Applications

- Sports and fitness equipment
- Health and medical equipment
- Consumer health devices
- Consumer electronics
- Wireless sensor networks

Development Tools and Software

- CC257x ANT development kit
- ANTware
- Integrated ANT-FS reference design
- ANT-FS PC host
- Embedded reference design

The CC2570 and CC2571 are ANT RF Network processors that implement the easy-to-use, power-efficient ANT[®] protocol. The CC2570 supports 1 ANT channel, while the CC2571 supports 8 ANT channels. The CC2570/71 can be connected to a host MCU (such as an MSP430[™]) through a UART or SPI[™] serial interface and accessed through a set of API calls. The majority of the ANT protocol is built into the CC2570/71, including the ANT-FS file system functionality; only the application and profile layers need to reside on the host MCU, thus keeping host MCU memory requirements to a minimum.

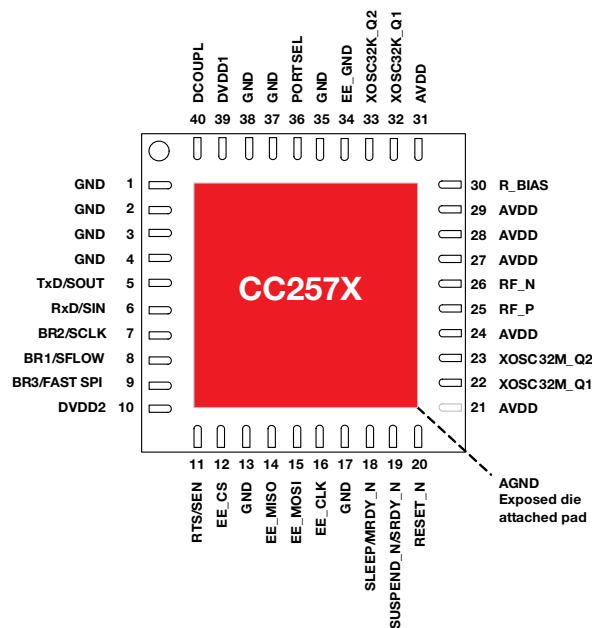

General characteristics

Parameter	Min	Typ	Max	Unit
Operating conditions				
Frequency range	2400		2507	MHz
Data rate	—		—	kBaud
Operating voltage	2.0	—	3.6	V
Operating temperature	-40	—	85	°C
Output power	-20	—	4	dBm
RX mode				
Receiver sensitivity	—	-85.8	—	dBm
Adjacent channel rejection, +2 MHz	—	-22	—	dB
Adjacent channel rejection, -2 MHz	—	-22	—	dB
Adjacent channel rejection, +4 MHz	—	—	—	dB
Adjacent channel rejection, -4 MHz	—	—	—	dB
Current consumption				
Current consumption, RX	—	23.7	—	mA
Current consumption, TX, +4 dBm	—	34.3	—	mA
Current consumption, TX, 0 dBm	—	28.8	—	mA
Current consumption, power down	—	<1	—	µA

→ Wireless Connectivity

WLAN 802.11 b/g/n and *Bluetooth*® v2.1 + EDR Transceiver WL1271-TiWi

NEW

Get samples, datasheets and app reports at: www.ti.com/wl1271-tiwi

Key Features

- IEEE 802.11 b/g/n compliant
- Typical WLAN Transmit power:
 - +20dBm, 11Mbps, CCK (b)
 - +14.5dBm, 54Mbps, OFDM (g)
 - +12.5dBm, 65Mbps, OFDM (n)
- Typical WLAN Receiver sensitivity:
 - -89dBm, 11Mbps
 - -76dBm, 54Mbps
 - -73dBm, 65Mbps
- *Bluetooth*® v2.1 + EDR (enhanced data rate)
 - Increased *Bluetooth* transmit power: +9.5dBm
 - -92dBm receiver sensitivity
- Best-in-class WLAN and *Bluetooth* coexistence technology on a single-chip
- Enhanced Low Power (ELP) technology for extended battery life
- On board TCXO, power regulation, and U.FL antenna connector
- HW and SW pre-integration with TI's AM/DM37x (ARM® Cortex®-A8), AM18xx (ARM9™), and OMAP™ 4 (ARM Cortex-A9) platforms
- SW-upgradable for ANT® & BLE
- FCC/IC/CE certified
- Dimensions: 13mm x 18mm x 1.9mm

The WL1271-TiWi is a fully-integrated high performance module offered by LS Research utilizing TI's single-chip WL1271 2.4GHz IEEE 802.11 b/g/n and *Bluetooth*® 2.1 + EDR Transceiver. Based on TI's 6th generation WLAN technology and 7th generation *Bluetooth* technology, the integrated solution provides best-in-class coexistence capabilities coupled with TI's Enhanced Low Power (ELP) technology. This solution is provided as a module to help customers reduce development time, lower manufacturing costs, save board space, ease certification, and minimize RF expertise required. For evaluation and development, various platforms are available which integrate the LS Research module, Linux drivers, *Bluetooth* stack, and sample source applications running on a TI host processor (AM/DM37x, AM18x, OMAP™ 4).

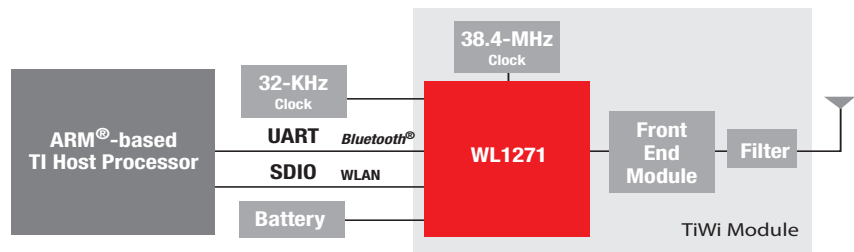

WL1271-TiWi system block diagram

Applications

- Industrial and home automation
- Point of sale and point of purchase
- Video conferencing, video camera and VoIP
- Consumer devices
- Medical devices
- Security and surveillance

Wireless Connectivity

Device	Description	Frequency Range	Device Type	Data Rate (Max) (max) (kbps)	Tx Power (max) (dBm)	RX Current (Lowest) (mA)	Sensitivity (Best) (dBm)	Wakeup Time (PD-->RX/TX) (μs)	Flash Size (KB)	RAM Size (KB)	Package(s)	Price*
CC1100E	Low-Power Sub-1GHz RF Transceiver for China and Japan frequency bands	Sub 1-GHz	Transceiver	500	12	15	-112	240	—	—	VQFN-20	1.70
CC1101	Low-Power Sub-1GHz RF Transceiver	Sub 1-GHz	Transceiver	500	12	14	-112	240	—	—	VQFN-20	1.65
CC1110	Sub 1-GHz System-on-Chip with MCU and 8kB Flash memory	Sub 1-GHz	System-on-Chip	500	10	16.2	-110	330	8, 16, 32	1, 2, 4	VQFN-36	2.10
CC1111	Sub 1-GHz System-on-Chip with MCU, 8kB Flash memory and USB 2.0	Sub 1-GHz	System-on-Chip	500	10	16.2	-110	330	8, 16, 32	1, 2, 4	VQFN-36	2.30
CC1190	Sub-1GHz RF Front End	850MHz-950MHz	RF Front End	—	27	3.0	—	—	—	—	VQFN-16	See Distributors
CC2420	CC2420	2.4GHz	Transceiver	250	0	18.8	-95	1200	—	—	VQFN-48	3.30
CC2500	Low Cost, Low-Power 2.4GHz RF Transceiver Designed for Low-Power Wireless Apps in the 2.4GHz ISM B	2.4GHz	Transceiver	500	1	12.8	-104	240	—	—	VQFN-20	1.40
CC2510	2.4GHz Radio Transceiver, 8051 MCU and 8 kB Flash memory	2.4GHz	System-on-Chip	500	1	15.7	-103	340	8, 16, 32	1, 2, 4	VQFN-36	1.95
CC2511	2.4GHz Radio Transceiver, 8051 MCU, 8kB Flash Memory and Full-Speed USB Interface	2.4GHz	System-on-Chip	500	1	15.7	-103	340	8, 16, 32	1, 2, 4	VQFN-36	2.15
CC2520	Second Generation 2.4GHz ZigBee®/IEEE 802.15.4 RF Transceiver	2.4GHz	Transceiver	250	4	18.5	-98	500	—	—	VQFN-28	1.80
CC2530	Second Generation System-on-Chip Solution for 2.4GHz IEEE 802.15.4/RF4CE/ZigBee	2.4GHz	System-on-Chip	250	4	20.5	-97	600	32, 64, 128, 256	8	VQFN-40	2.75
CC2531	System-on-Chip Solution for IEEE 802.15.4 and ZigBee Applications	2.4GHz	System-on-Chip	250	4	20.5	-97	600	128, 256	8	VQFN-40	3.20
CC2533	A True System-on-Chip Solution for 2.4GHz IEEE 802.15.4 and ZigBee Applications	2.4GHz	System-on-Chip	250	4	21.6	-97	600	32, 64, 96	4, 4, 6	VQFN-40	2.55
CC2540	2.4GHz <i>Bluetooth</i> ® Low Energy System-on-Chip Solution	2.4GHz	System-on-Chip	1000	4	19.6	-93	530	128, 256	8	VQFN-40	2.95
CC2560-PAN1315	<i>Bluetooth</i> 2.1 + EDR Transceiver, Class 2 HCI Module	2.4GHz	Module	2178	10	—	-93	—	—	—	Surface Mount Module: 6.5x9x1.8 mm ³	See Distributors
CC2560 - PAN1325	<i>Bluetooth</i> 2.1 + EDR Transceiver, Class 2 HCI Module, Integrated Antenna	2.4GHz	Module, Integrated Antenna	2178	10	—	-93	—	—	—	Surface Mount Module: 9.5x9x1.8 mm ³	See Distributors
CC2567-PAN1317	Dual-mode <i>Bluetooth</i> 2.1 + EDR and ANT® Transceiver Module	2.4GHz	Module	2178	+10	—	-93	—	—	—	Surface mount Module: 6.5x9x1.8 mm ³	See Distributors
CC2567-PAN1327	Dual-mode <i>Bluetooth</i> 2.1 + EDR and ANT Transceiver Module with Integrated Antenna	2.4GHz	Module, Integrated Antenna	2178	+10	—	-93	—	—	—	Surface mount Module: 9.5x9x1.8 mm ³	See Distributors
CC2590	2.4GHz RF Front End	2.4GHz	RF Front End	—	10	3.4	—	1	—	—	VQFN-16	1.55
CC2591	2.4GHz RF Front End	2.4GHz	RF Front End	—	20	3.4	—	1	—	—	VQFN-16	1.75
CC2595	RF Front-End Transmit Power Amplifier for 2.4GHz ISM Band Systems	2.4GHz	RF Front-End	—	20	—	—	1	—	—	QFN-16	0.65
CC8520	PurePath™ Wireless™ 2.4GHz RF SoC for Wireless Digital Audio Streaming	2.4GHz	Network processor	5000	4	25	-83/-87	NA	Yes	Yes	VQFN-40	3.75
WL1271-TIWI	WLAN IEEE 802.11 b/g/n and <i>Bluetooth</i> 2.1 + EDR Transceiver Module	2.4GHz	Module	6500	+20.0 (802.11b) +14.5 (802.11g) +12.5 (802.11n)	100	-89 (802.11b) -76 (802.11g) -73 (802.11n)	—	—	—	Surface Mount Module: 13x18x1.9 mm ³	See Distributors

*Suggested resale price in U.S. dollars in quantities of 1,000.

New products are listed in bold red.

→ Design and Evaluation Tools



TI's Analog eLab™ Design Center offers support and training for new and experienced analog device developers for a variety of analog design needs, all focused on the development and design of analog devices. At the Analog eLab, design engineers can learn with training and webcast sessions, select products through parametric analysis, design with our “Pro” series, simulate with different model resources, and obtain free samples of TI products within 24 hours. www.ti.com/analogelab



Learn

- Online Training
- Analog eLab™ Videocasts
- KnowledgeBase and Document Finder
- Application Notes/ Technical Documents



Select

- Clocks and Timing Quick Search
- Interface Quick Search
- Power Management
 - Power Quick Search
 - Discover How T2 Modules Can Reduce Your Output Capacitance
 - Battery Chargers Quick Search
- Data Converters
 - Analog to Digital Converters
 - Digital to Analog Converters
- Audio
 - New PurePath™ Audio™ Power Stage Selection Tool
 - Audio Quick Search
- RF/IF Component Quick Search
- Analog Switches Quick Search
- Translation Device Selection Tool
- Selection Guides
- End-Equipment Solutions
- Parametric Search
- Competitor Cross-Reference Search



Design

- TI Pro Series
 - SwitcherPro™ Design Software
 - SwitcherPro Info
 - Download Now
 - Use Online Now
 - Learn How to Create a Design with SwitcherPro
 - ADCPro™ Evaluation Software
 - ClockPro™ Programming Software
 - MDACBufferPro™ Design Software
 - Updated FilterPro™ v3.0 Design Software
- Reference Designs
- TI Gadgets and Widgets
- Calculators and Other Utilities
- New PCB Thermal Calculator
- Hardware Design Tools and Software
- Quality, Reliability and Lead (Pb)-Free
- RoHS Content and Delivery Schedule
- Packaging Information



Simulate

- TINA-TI™ Powerful and Easy-to-Use Circuit Simulation Program
- Complete SPICE Model Libraries
- IBIS and BSDL Model Libraries



Sample

- Pricing and Availability
- Request Samples
- TI eStore
 - Browse Evaluation Modules
- TI Worldwide Sales and Support Offices
- Distributors
- Sales Representatives

TI Worldwide Technical Support

Internet

TI Semiconductor Product Information Center Home Page

support.ti.com

TI E2E™ Community Home Page

e2e.ti.com

Product Information Centers

Americas	Phone	+1 (972) 644-5580
Brazil	Phone	0800-891-2616
Mexico	Phone	0800-670-7544
	Fax	+1 (972) 927-6377
	Internet/Email	support.ti.com/sc/pic/americas.htm

Europe, Middle East, and Africa

Phone	
European Free Call	00800-ASK-TEXAS (00800 275 83927)
International	+49 (0) 8161 80 2121
Russian Support	+7 (4) 95 98 10 701

Note: The European Free Call (Toll Free) number is not active in all countries. If you have technical difficulty calling the free call number, please use the international number above.

Fax	+ (49) (0) 8161 80 2045
Internet	support.ti.com/sc/pic/euro.htm
Direct Email	asktexas@ti.com

Japan

Phone	Domestic	0120-92-3326
Fax	International	+81-3-3344-5317
	Domestic	0120-81-0036
Internet/Email	International	support.ti.com/sc/pic/japan.htm
	Domestic	www.tij.co.jp/pic

The platform bar, ADCPro, Analog eLab, C2000, ClockPro, ControlNet, DaVinci, Difet, DirectPath, E2E, eLab, FilterPro, FlatLink, LinCMOS, MDACBufferPro, MicroStar Junior, MSP430, OHCI-Lynx, OMAP, Panelbus, PicoStar, PowerPAD, PowerTune, PurePath, PurePath™ Audio, PurePath™ Digital, PurePath™ HD, PurePath™ Wireless, QSPI, Sitara, SmartGain, SoundPlus, SpeakerGuard, SwitcherPro, SymPol, TINA-TI and VLYNQ are trademarks and Stellaris is a registered trademark of Texas Instruments. ANT is a registered trademark of Dynastream Innovations, Inc. ARM9 is a trademark and ARM and Cortex are registered trademarks of ARM Limited. The *Bluetooth* word mark and logos are owned by the Bluetooth SIG, Inc., and any

use of such marks by Texas Instruments is under license. Blu-ray is a trademark of Blu-ray Disc Association. DeviceNet is a trademark of Open DeviceNet Vendor Association, Inc. FireWire is a registered trademark of Apple Computer Incorporated. I²C Bus is a registered trademark of NXP B.V. Corporation. i.LINK is a registered trademark of Sony Corporation. Microwire is a registered trademark of National Semiconductor Corporation. Modbus is a registered trademark of Modbus Organization, Inc. SB1394 is a trademark of Creative Technology Ltd. SPI is a trademark of Motorola, Inc. ZigBee is a registered trademark of the ZigBee Alliance. All other trademarks are the property of their respective owners.

Asia

Phone	
International	+91-80-41381665
Domestic	<u>Toll-Free Number</u>
Note:	Toll-free numbers do not support mobile and IP phones.
Australia	1-800-999-084
China	800-820-8682
Hong Kong	800-96-5941
India	1-800-425-7888
Indonesia	001-803-8861-1006
Korea	080-551-2804
Malaysia	1-800-80-3973
New Zealand	0800-446-934
Philippines	1-800-765-7404
Singapore	800-886-1028
Taiwan	0800-006800
Thailand	001-800-886-0010

Fax	+8621-23073686
Email	tiasia@ti.com or ti-china@ti.com
Internet	support.ti.com/sc/pic/asia.htm

Important Notice: The products and services of Texas Instruments Incorporated and its subsidiaries described herein are sold subject to TI's standard terms and conditions of sale. Customers are advised to obtain the most current and complete information about TI products and services before placing orders. TI assumes no liability for applications assistance, customer's applications or product designs, software performance, or infringement of patents. The publication of information regarding any other company's products or services does not constitute TI's approval, warranty or endorsement thereof.

A122010

IMPORTANT NOTICE

Texas Instruments Incorporated and its subsidiaries (TI) reserve the right to make corrections, modifications, enhancements, improvements, and other changes to its products and services at any time and to discontinue any product or service without notice. Customers should obtain the latest relevant information before placing orders and should verify that such information is current and complete. All products are sold subject to TI's terms and conditions of sale supplied at the time of order acknowledgment.

TI warrants performance of its hardware products to the specifications applicable at the time of sale in accordance with TI's standard warranty. Testing and other quality control techniques are used to the extent TI deems necessary to support this warranty. Except where mandated by government requirements, testing of all parameters of each product is not necessarily performed.

TI assumes no liability for applications assistance or customer product design. Customers are responsible for their products and applications using TI components. To minimize the risks associated with customer products and applications, customers should provide adequate design and operating safeguards.

TI does not warrant or represent that any license, either express or implied, is granted under any TI patent right, copyright, mask work right, or other TI intellectual property right relating to any combination, machine, or process in which TI products or services are used. Information published by TI regarding third-party products or services does not constitute a license from TI to use such products or services or a warranty or endorsement thereof. Use of such information may require a license from a third party under the patents or other intellectual property of the third party, or a license from TI under the patents or other intellectual property of TI.

Reproduction of TI information in TI data books or data sheets is permissible only if reproduction is without alteration and is accompanied by all associated warranties, conditions, limitations, and notices. Reproduction of this information with alteration is an unfair and deceptive business practice. TI is not responsible or liable for such altered documentation. Information of third parties may be subject to additional restrictions.

Resale of TI products or services with statements different from or beyond the parameters stated by TI for that product or service voids all express and any implied warranties for the associated TI product or service and is an unfair and deceptive business practice. TI is not responsible or liable for any such statements.

TI products are not authorized for use in safety-critical applications (such as life support) where a failure of the TI product would reasonably be expected to cause severe personal injury or death, unless officers of the parties have executed an agreement specifically governing such use. Buyers represent that they have all necessary expertise in the safety and regulatory ramifications of their applications, and acknowledge and agree that they are solely responsible for all legal, regulatory and safety-related requirements concerning their products and any use of TI products in such safety-critical applications, notwithstanding any applications-related information or support that may be provided by TI. Further, Buyers must fully indemnify TI and its representatives against any damages arising out of the use of TI products in such safety-critical applications.

TI products are neither designed nor intended for use in military/aerospace applications or environments unless the TI products are specifically designated by TI as military-grade or "enhanced plastic." Only products designated by TI as military-grade meet military specifications. Buyers acknowledge and agree that any such use of TI products which TI has not designated as military-grade is solely at the Buyer's risk, and that they are solely responsible for compliance with all legal and regulatory requirements in connection with such use.

TI products are neither designed nor intended for use in automotive applications or environments unless the specific TI products are designated by TI as compliant with ISO/TS 16949 requirements. Buyers acknowledge and agree that, if they use any non-designated products in automotive applications, TI will not be responsible for any failure to meet such requirements.

Following are URLs where you can obtain information on other Texas Instruments products and application solutions:

Products

Audio	www.ti.com/audio
Amplifiers	amplifier.ti.com
Data Converters	dataconverter.ti.com
DLP® Products	www.dlp.com
DSP	dsp.ti.com
Clocks and Timers	www.ti.com/clocks
Interface	interface.ti.com
Logic	logic.ti.com
Power Mgmt	power.ti.com
Microcontrollers	microcontroller.ti.com
RFID	www.ti-rfid.com
RF/IF and ZigBee® Solutions	www.ti.com/lprf

Applications

Communications and Telecom	www.ti.com/communications
Computers and Peripherals	www.ti.com/computers
Consumer Electronics	www.ti.com/consumer-apps
Energy and Lighting	www.ti.com/energy
Industrial	www.ti.com/industrial
Medical	www.ti.com/medical
Security	www.ti.com/security
Space, Avionics and Defense	www.ti.com/space-avionics-defense
Transportation and Automotive	www.ti.com/automotive
Video and Imaging	www.ti.com/video
Wireless	www.ti.com/wireless-apps

TI E2E Community Home Page

e2e.ti.com

Mailing Address: Texas Instruments, Post Office Box 655303, Dallas, Texas 75265
Copyright © 2011, Texas Instruments Incorporated