

AD9122	Dual Channel, 1.2 GSPS, 16-Bit, TxDAC® Digital-to Analog Converter
ADL5375	Broadband Quadrature Modulator

Interfacing the ADL5375 I/Q Modulator to the AD9122 Dual Channel, 1.2 GSPS High Speed DAC

EVALUATION AND DESIGN SUPPORT

Circuit Evaluation Boards

[AD9122/ADL5375 Evaluation Board \(AD9122-M5375-EBZ\)](#)

Design and Integration Files

[Schematics, Layout Files, Bill of Materials](#)

CIRCUIT FUNCTION AND BENEFITS

This circuit provides a simple and flexible interface between the [AD9122](#) dual high speed TxDAC digital-to-analog converter and the [ADL5375-05](#) broadband I/Q modulator. Because the DAC outputs and [ADL5375-05](#) I/Q modulator inputs share a common bias level of 0.5 V, there is no need for any active or passive level shifting circuitry. The dc coupled interface facilitates I/Q modulator local oscillator (LO) leakage compensation by the DAC.

The 1.2 GSPS [AD9122](#) DAC sampling rate and the wide bandwidth of the [ADL5375-05](#) modulator I and Q inputs ensure that both zero-IF (ZIF) or complex-IF (CIF) architectures can be supported. In addition to filtering Nyquist images, the baseband filter provides excellent rejection of both differential-mode and common-mode DAC spurs.

CIRCUIT DESCRIPTION

The circuit and board shown in Figure 1 and Figure 2 utilize the [AD9122](#) TxDAC and the [ADL5375-05](#) wideband transmit modulator. Signal biasing and scaling in the interface circuit is controlled by the four ground-referenced resistors (RBIP, RBIN, RBQP, RBQN) and the two shunt resistors (RSLI, RSLQ), respectively.

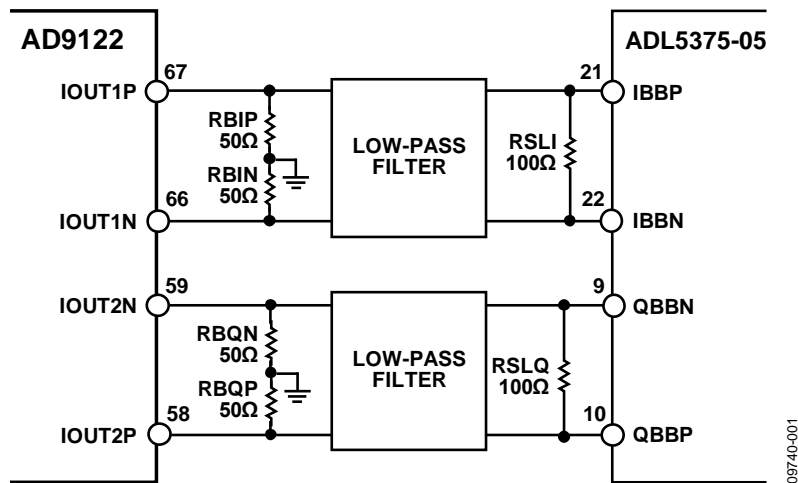

Figure 1. Interface Between the [AD9122](#) and [ADL5375-05](#) with 50 Ω Resistors to Ground to Establish the 500 mV DC Bias for the [ADL5375-05](#) Baseband Inputs (Simplified Schematic)

Rev. 0

Circuits from the Lab™ circuits from Analog Devices have been designed and built by Analog Devices engineers. Standard engineering practices have been employed in the design and construction of each circuit, and their function and performance have been tested and verified in a lab environment at room temperature. However, you are solely responsible for testing the circuit and determining its suitability and applicability for your use and application. Accordingly, in no event shall Analog Devices be liable for direct, indirect, special, incidental, consequential or punitive damages due to any cause whatsoever connected to the use of any Circuits from the Lab circuits. (Continued on last page)

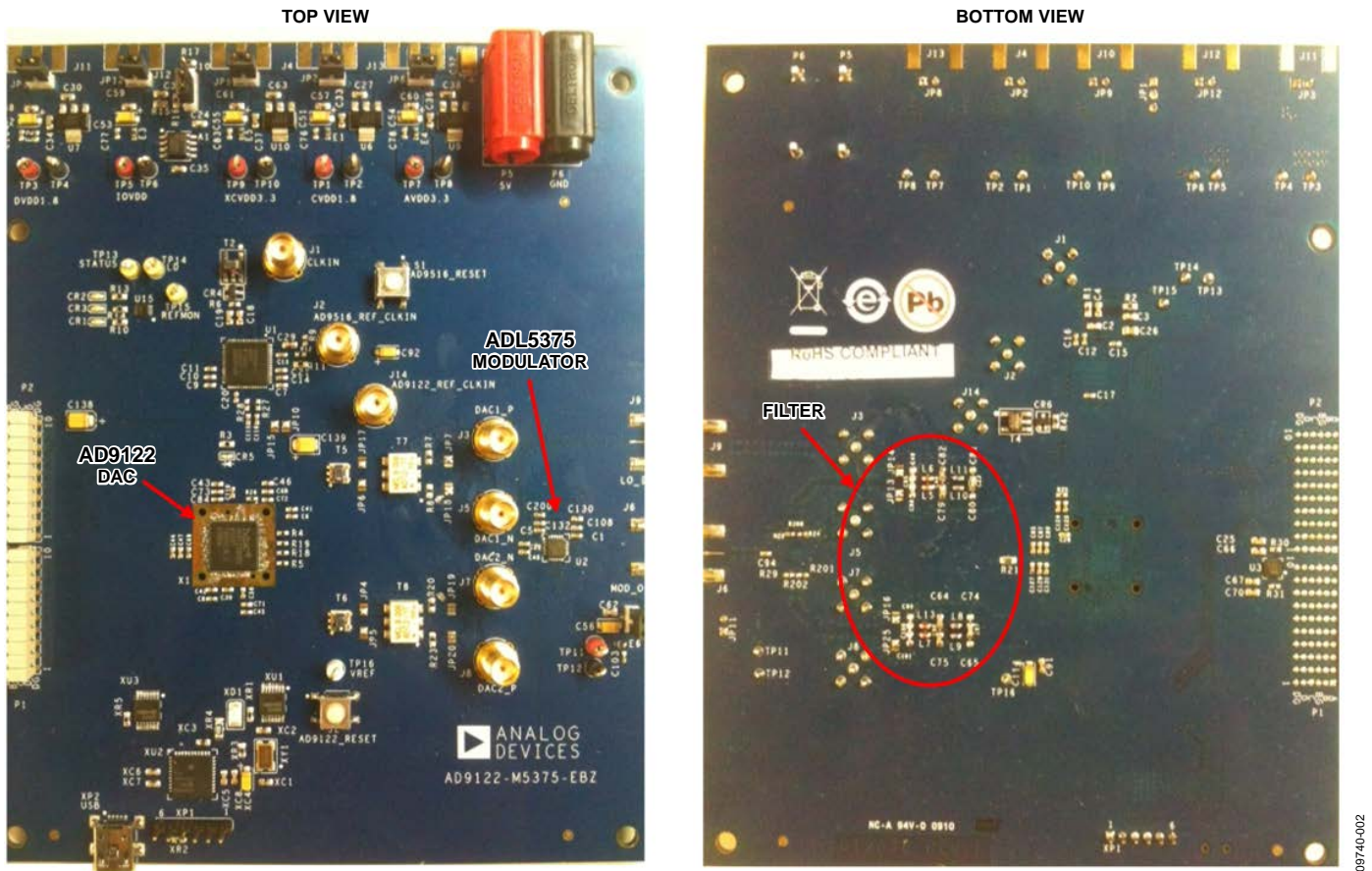

Figure 2. AD9122-M5375-EBZ Evaluation Board for Circuit Implementation

The DAC's full-scale output current (I_{FS}) is programmable from 10 mA to 30 mA. The nominal and default value is 20 mA. In this configuration, the DAC outputs swing from 0 mA to 20 mA across each of the four ground-referenced 50 Ω resistors ($R_B = RBIP = RBIN = RBQP = RBQN$). This establishes the 500 mV dc bias level and a full-scale voltage swing of 2 V p-p differential on each output pair (with no load). This 2 V p-p voltage swing can be adjusted by the R_L ($R_L = RSLI = RSLQ$) shunt resistors without affecting the 500 mV bias level. The resulting differential peak-to-peak swing at the I/Q modulator input is given by the equation

$$V_{SIGNAL} = I_{FS} \times \left[\frac{2 \times R_B \times R_L}{2 \times R_B + R_L} \right]$$

Note that the relatively high differential input impedance of the [ADL5375](#) (typically >60 k Ω) can be ignored when calculating this signal level. Figure 3 shows the relationship between the peak-to-peak voltage swing and R_L when 50 Ω bias-setting resistors are used.

The [ADL5375-05](#) and [AD9122](#) are well matched in terms of dynamic range and gain. As a result, there is no need for any active gain between the devices. The I/Q modulator drive level can be fine tuned as needed by adjusting the value of R_L as described above. For most applications, a value of 100 Ω for R_L is recommended. This results in a full-scale signal level of 1 V p-p (DAC output at 0 dBFS).

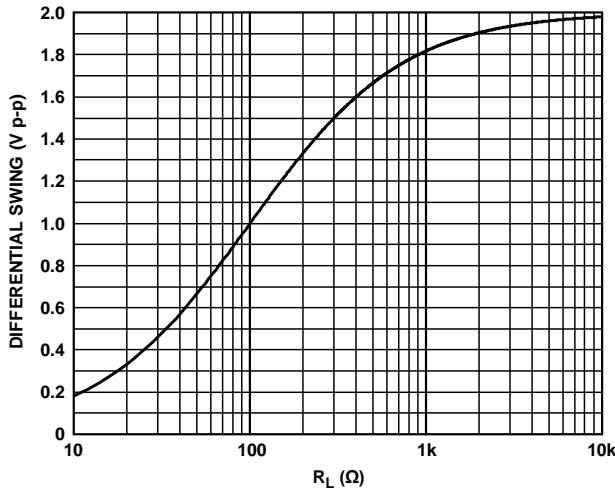

Figure 3. Peak-to-Peak Differential Swing and the Swing Limiting Resistor (R_L) with $50\ \Omega$ Bias-Setting Resistors

Baseband Filtering

A filter must be inserted between the AD9122 and ADL5375 to remove Nyquist images, spurs, and broadband noise originating from the DAC. The filter should be placed between the dc bias setting resistors and the ac swing-limiting resistor. With this configuration, the dc bias setting resistors (R_B in Figure 4) and the signal scaling resistors (R_L in Figure 4) conveniently set the source and load resistances for the filter design.

Figure 4 shows a third-order Bessel low-pass filter with a $-3\ \text{dB}$ frequency of 10 MHz. Matching input and output impedances of the filter makes the filter design easy and results in better passband flatness, which allows wide bandwidth filter designs. In this example, the shunt resistor chosen is $100\ \Omega$, producing an ac swing of 1 V p-p differential. The frequency response of this filter is shown in Figure 5.

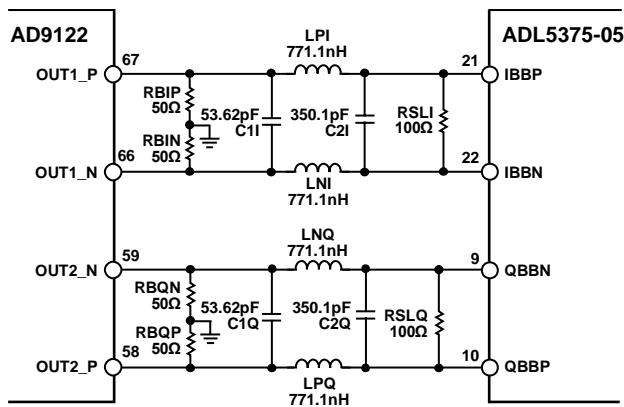

Figure 4. DAC Modulator Interface with 10 MHz Third-Order, Bessel Filter

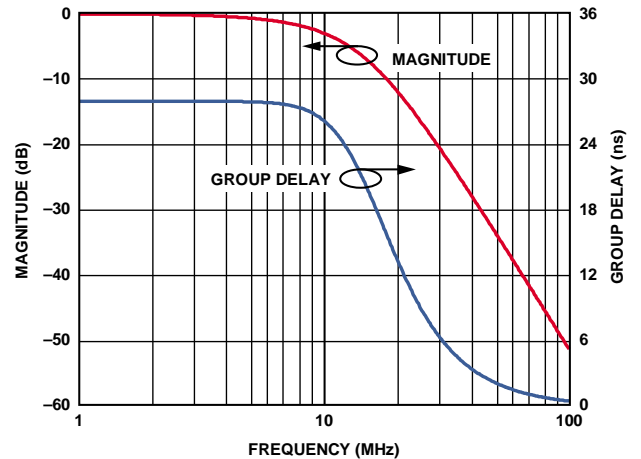

Figure 5. Frequency Response for DAC Modulator Interface with 10 MHz Third-Order Bessel Filter

Filtering for Complex IF (CIF) Applications

Figure 6 shows the frequency response of the ADL5375 baseband I and Q inputs. Because this device has a wide and flat frequency response ($-3\ \text{dB}$ point = 750 MHz), it is well suited to complex IF (CIF) applications where the output signal from the DAC has been digitally upconverted. In CIF applications, a low-pass Nyquist filter is still desirable, primarily because the dc bias level can be preserved from the DAC output to the modulator input.

The filter topology shown in Figure 7 is a 5th order Butterworth filter with a 300 MHz corner frequency and is the recommended filter topology. A purely differential filter can reject differential-mode images, spurs, and noise from the DAC. Using two capacitors with their common connection grounded (C2 and C4 in Figure 7) diverts some of the common-mode current to ground and results in better common-mode rejection of high-frequency signals than would be obtained with a purely differential filter.

The simulated and measured responses of this filter are shown in Figure 8 and Figure 9. The measured flatness is $\pm 0.6\ \text{dB}$ from dc to 250 MHz and $\pm 0.4\ \text{dB}$ from 125 MHz to 250 MHz. This data was taken with the AD9122 inverse sinc function on. In this configuration, Figure 10 shows the common-mode rejection performance of the $2 \times F_{\text{DAC}}$ common-mode spur vs. common-mode frequency with and without IF filter shown in Figure 7.

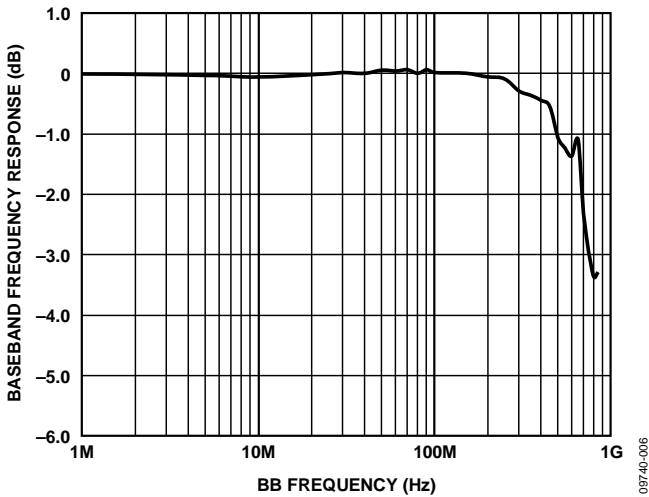

Figure 6. Baseband (BB) Frequency Response of ADL5375-05

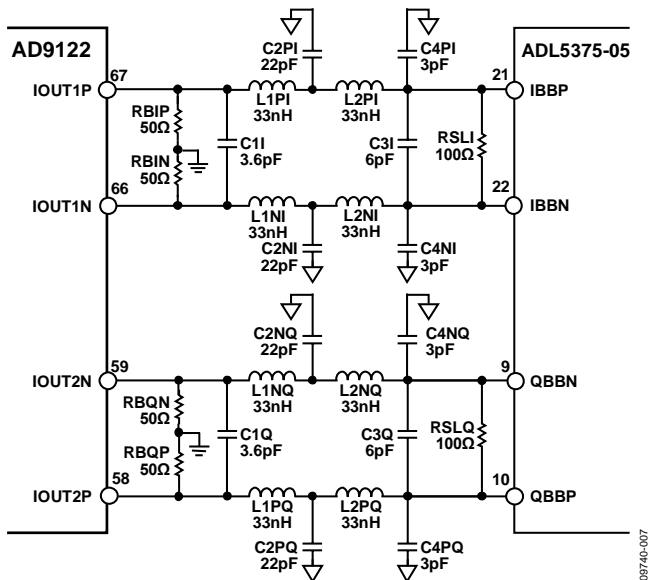

Figure 7. Recommended DAC Modulator Interface topology with $F_c = 300$ MHz Fifth-Order, Butterworth Filter

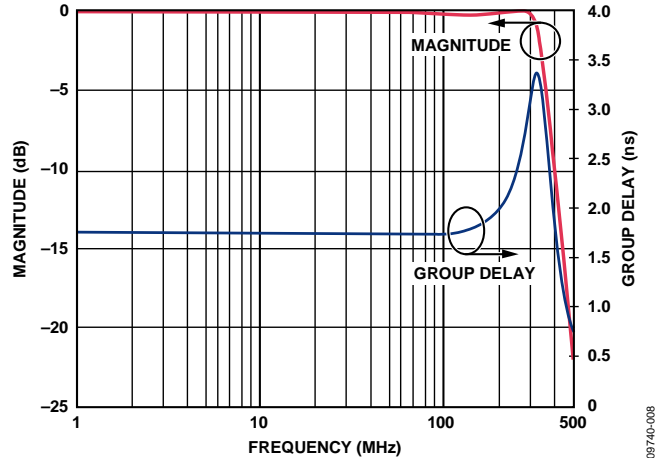

Figure 8. Frequency Response for DAC Modulator Interface with 300 MHz Fifth-Order Butterworth Filter (Simulated)

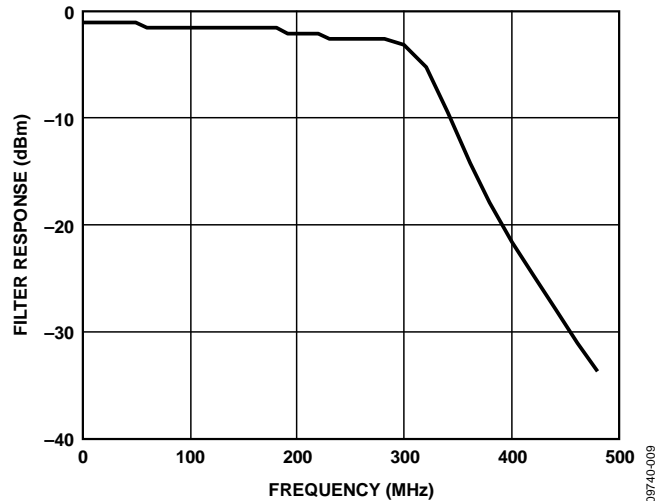

Figure 9. Measured Frequency Response for DAC Modulator Interface with 300 MHz Fifth-Order Butterworth Filter

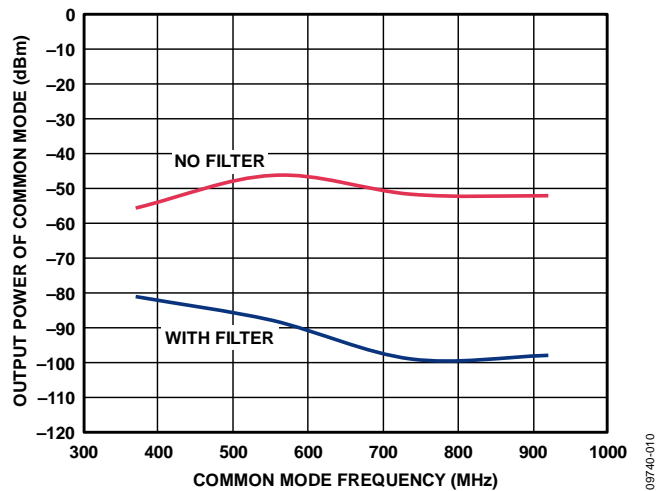

Figure 10. Measured Common-Mode Rejection Performance at ADL5375-05 RF output with Filter and without Filter

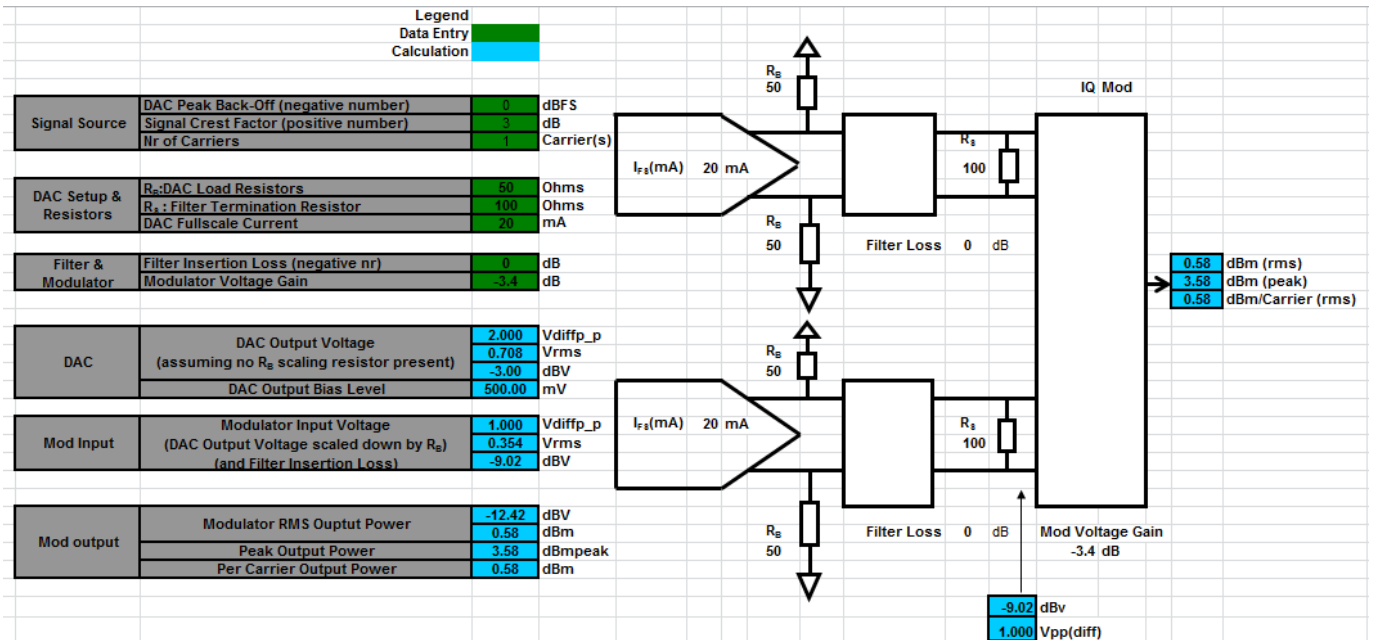

Figure 11. Spreadsheet to Calculate Modulator Output Power

Calculating the Output Power of the AD9122 and the ADL5375

In addition to the bias-setting and signal scaling resistors, the power level at the output of the ADL5375 is a function of the DAC’s digital backoff level (dBFS), the signal’s peak-to-average ratio, the DAC’s full-scale current, the insertion loss of the Nyquist filter, and I/Q modulator’s voltage gain. The spreadsheet shown in Figure 11 can be used to make this calculation.

This spreadsheet can be downloaded using the following URL: www.analog.com/CN0205-PowerCalculator.

Level Shifting to Drive the ADL5375-15

The ADL5375-15 requires a dc bias level of 1500 mV. Other than the difference in bias levels, the ADL5375-05 and ADL5375-15 are identical. To drive the ADL5375-15 from the AD9122, either a passive or active level-shifting network must be used. The passive level shifting network shown in Figure 12 uses four series resistors along with four pull-up resistors to achieve a bias level of 1500 mV at the ADL5375-15 input. This passive level shifting network introduces a loss of approximately 2 dB in the signal level.

An active level shifting circuit would use a dual-differential amplifier, such as ADA4938, where placing 1500 mV on the VOVM pin sets the output dc bias level. In this approach, however, the interface bandwidth is limited by the op amp.

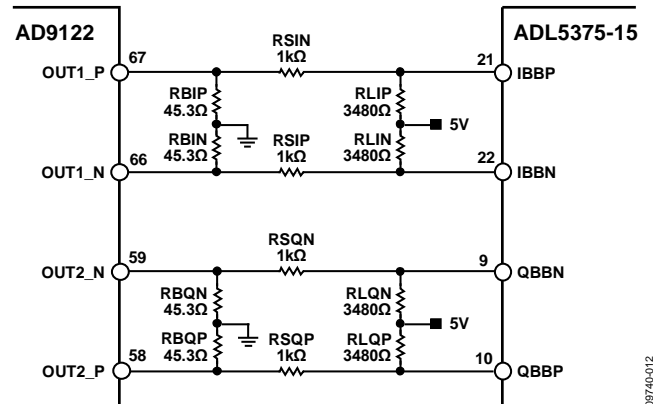

Figure 12. Passive Level-Shifting Network For Biasing ADL5375-15 from the AD9122 TxDAC

As previously mentioned, it is necessary to put a filter between AD9122 and ADL5375-15. The LC filter can be located anywhere between the DAC termination resistors (R1 in Figure 13) and the ac swing-limiting resistor (R4 in Figure 13). However, the circuit in Figure 13 allows flexibility in the design of the level shifting circuit with low loss by R2 and a high driving level to modulator. It also allows a matched filter at source and load impedance. Figure 13 is the recommended passive level-shifting network with filter.

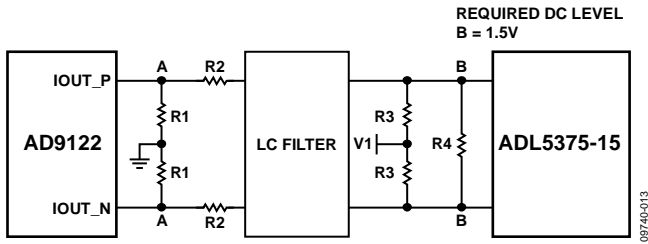

Figure13. Recommended Passive Level-Shifting Network with LC Filter

The differential source impedance and load impedance of the filter are

$$2 \times (R1 + R2) \text{ and } 2 \times \{R3 \parallel (R4/2)\}, \text{ respectively.}$$

The single-ended impedance seen by DAC is

$$R1 \parallel \{R2 + R3 \parallel (R4/2)\}.$$

R4 acts as the ac load to the DAC. The differential ac swing at DAC output is

$$2 \times I_{ES} \times R1 \parallel \{R2 + R3 \parallel (R4/2)\},$$

and the differential ac swing at the modulator input is

$$2 \times \{R3 \parallel (R4/2)\} \div \{R2 + (R3 \parallel (R4/2))\}$$

multiplied by the differential ac swing at DAC output.

SETUP	R1 (Ω)	34.0
	R2 (Ω)	218
	R3(Ω)	760
	R4 (Ω)	750
	IFS (MA)	20
	V1 (V)	5.00
	DAC R (SINGLE)	31.70
DAC	DAC COMMON VOLTAGE (V)	0.50
	DAC SWING (V p_p) (SINGLE)	0.63
MOD	MODULATOR COMMON VOLTAGE (V)	1.50
	MOD INPUT SWING (V p_p)	0.34
	(SINGLE) LOSS BY R2 (DB)	-5.43
FILTER	INPUT IMPEDANCE (Ω)	504
	OUTPUT IMPEDANCE (Ω)	502

Figure14. Spreadsheet for the Level Shifting Circuit

The LC filter should be placed close to the DAC to allow short return current path. The 5 V bias supply (V1) should be close to the modulator because it is shared with the modulator. For the case when R1, R2, R3, and R4 are 34 Ω, 218 Ω, 760 Ω, and 750 Ω, respectively, the 500 mV dc bias at the AD9122 DAC output is matched to the 1500 mV dc bias at ADL5375-15. Actually, it is not necessary to be 500 mV at point A of Figure 13, but it will give flexibility in the ac swing level without exceeding the compliance voltage of the DAC output. The DAC load is 31.7 Ω. The input and output impedance of the filter are 504 Ω and 502 Ω. The attenuation by R2, which is the voltage drop by R2 between the DAC output and modulator input, is set by the combination of R2 and $R3 \parallel (R4/2)$, which is about 5.4 dB.

To calculate dc bias level and ac swing level at the A and B points (Figure 13), attenuation by R2, and source/load impedances of the filter, the spreadsheet below can be used.

This can be downloaded at the following URL: www.analog.com/CN0205-LevelShifter.

The ADIsimRF tool can also be used to perform DAC-modulator power level calculations. The tool can be downloaded from www.analog.com/ADIsimRF.

Layout Recommendations

Special care should be taken in the layout of the DAC/modulator interface. Here are some recommendations. Figure 15 shows a top-level layout, which follows these recommendations:

- Keep all I/Q differential trace lengths well matched.
- Place filter termination resistor as close as possible to modulator input.
- Place DAC output 50 Ω resistors as close as possible to DAC.
- Thicken trace widths through the filter network to reduce signal loss.
- Place vias around all DAC output traces, filter networks, modulator output traces, and LO input traces.
- Route LO and modulator outputs on different layers or at 90° angle to each other to prevent coupling.

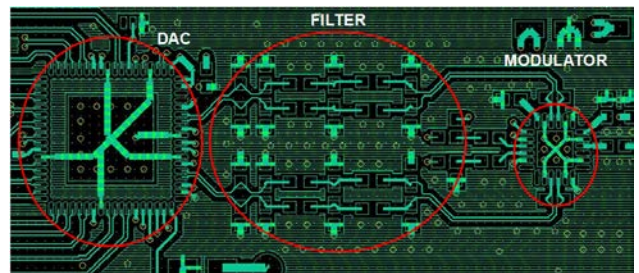

Figure15. General Layout Recommendations

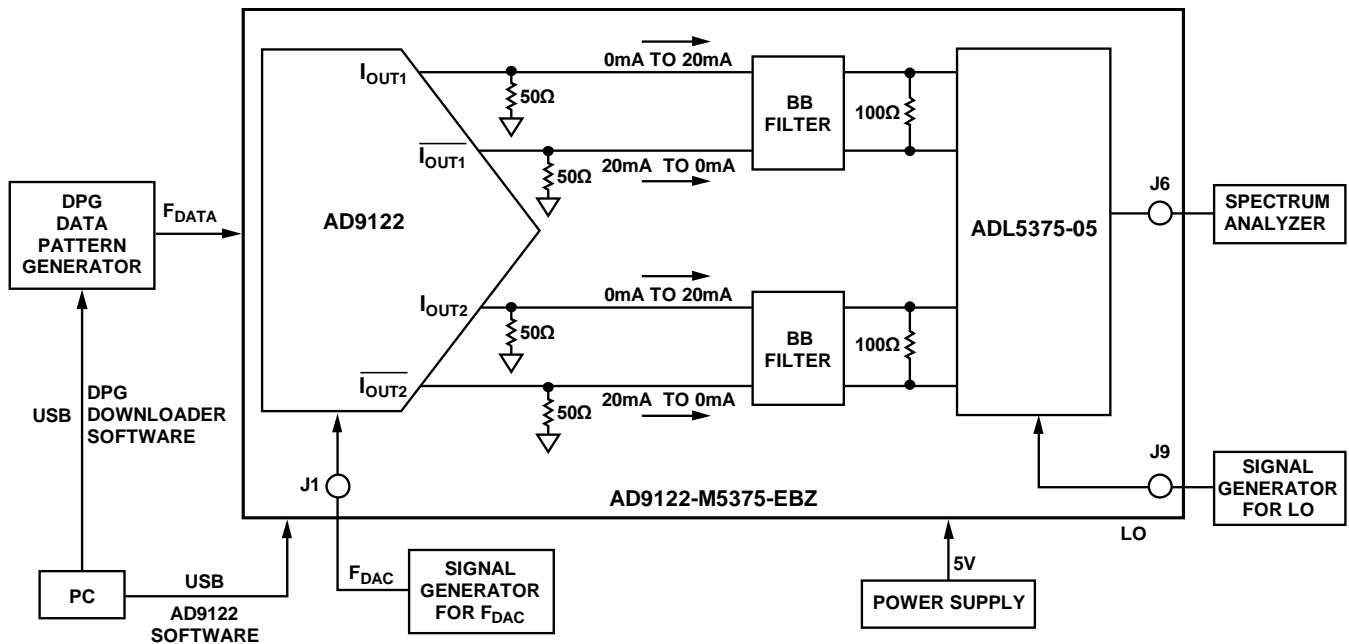

Figure 16. Test Setup Functional Block Diagram

Further insight to proper layout can be found by examining the AD9122-M5375-EBZ layout files in the design support package www.analog.com/CN0205-DesignSupport.

COMMON VARIATIONS

The interface described in this circuit note can be used between any TxDAC digital-to-analog converter (AD9779A, AD9788, AD9125, AD9148) that is set for 20 mA full-scale current and the ADL5370, ADL5371/ADL5372, ADL5373, ADL5374, ADL5385, ADL5386, etc., family of I/Q modulators that require 0.5 V baseband dc bias levels.

The interface can also be adapted to the AD8345/AD8349 low current modulators, with some adjustment to the bias level by properly selecting the DAC termination resistors.

CIRCUIT EVALUATION AND TEST

The following section describes details of performing the common-mode test (results shown in Figure 10). The test setup is flexible and allows other measurements shown in this circuit note to be performed.

Equipment Needed (Equivalents Can be Substituted)

- DPG : ADI Digital Pattern Generator
- Signal Generator for clock: Agilent E4437B
- Signal generator for LO: Agilent 8665B
- Spectrum analyzer: Agilent E4440A
- Power supply: Agilent E3631A

Setup and Test

1. Connect the setup and measurement system shown in Figure 16.
2. Set the power supply to +5 V.
3. Set the signal generator for F_{DAC} to 368.64 MHz @ 5 dBm, and the signal generator for LO to 2140 MHz @ 0 dBm.
4. Turn on the power supply and signal generators. Set the spectrum analyzer at $2 \times F_{DAC}$ MHz, 1 MHz span.
5. Set up the AD9122 through USB at AD9122/AD9125 SPI control software as shown in Figure 17 and run. Refer to the AD9122 Evaluation Board Quick Start Guide in www.analog.com-CN0205-DesignSupport.
 - Interpolation ("1" in Figure 17) : $1 \times$
 - Fine modulation ("2" in Figure 17) : ON
 - Data rate ("3" in Figure 17) : same as F_{DAC} frequency
 - NCO frequency ("4" in Figure 17) : 173.32 MHz
6. Set up DPG (refer to AD9122 Evaluation Board Quick Start Guide)
 - Make sure DCO frequency ("1" in Figure 18) is close to F_{DAC} frequency.
 - Set sample rate ("2" in Figure 18) same as F_{DAC} frequency and 1 MHz at desired frequency.

LEARN MORE

CN0205 Design Support Package:
www.analog.com/CN0205-DesignSupport

MT-016 Tutorial, *Basic DAC Architectures III: Segmented DACs*, Analog Devices.

MT-017 Tutorial, *Oversampling Interpolating DACs*, Analog Devices.

MT-031 Tutorial, *Grounding Data Converters and Solving the Mystery of 'AGND' and 'DGND'*, Analog Devices.

MT-101 Tutorial, *Decoupling Techniques*, Analog Devices.

CN-0021 Circuit Note, *Interfacing the ADL5375 I/Q Modulator to the AD9779A Dual-Channel, 1 GSPS High Speed DAC*, Analog Devices.

CN-0134 Circuit Note, *Broadband Low EVM Direct Conversion Transmitter*, Analog Devices.

CN-0144 Circuit Note, *Broadband Low EVM Direct Conversion Transmitter Using LO Divide-by-2 Modulator*, Analog Devices.

Nash, Eamon. AN-1039 Application Note, *Correcting Imperfections in IQ Modulators to Improve RF Signal Fidelity*, Analog Devices.

Zhang, Yi. AN-1100 Application Note, *Wireless Transmitter I/Q Balance and Sideband Suppression*, Analog Devices.

Brandon, David and David Crook, Ken Gentile, AN-0996, *The Advantages of Using a Quadrature Digital Upconverter (QDUC) in Point-to-Point Microwave Transmit Systems*, Analog Devices.

ADIsimPLL Design Tool

ADIsimRF Design Tool

AD9122 Evaluation Board Quick Start Guide

Analog Devices Data Pattern Generator (DPG)

Data Sheets and Evaluation Boards

[AD9122 Data Sheet](#)

[ADL5375 Data Sheet](#)

[AD9122 Evaluation Board](#)

[ADL5375-05 Evaluation Board](#)

[AD9122-M 5375-EBZ Evaluation Board](#)

REVISION HISTORY

8/11—Revision 0: Initial Version

(Continued from first page) Circuits from the Lab circuits are intended only for use with Analog Devices products and are the intellectual property of Analog Devices or its licensors. While you may use the Circuits from the Lab circuits in the design of your product, no other license is granted by implication or otherwise under any patents or other intellectual property by application or use of the Circuits from the Lab circuits. Information furnished by Analog Devices is believed to be accurate and reliable. However, "Circuits from the Lab" are supplied "as is" and without warranties of any kind, express, implied, or statutory including, but not limited to, any implied warranty of merchantability, noninfringement or fitness for a particular purpose and no responsibility is assumed by Analog Devices for their use, nor for any infringements of patents or other rights of third parties that may result from their use. Analog Devices reserves the right to change any Circuits from the Lab circuits at any time without notice but is under no obligation to do so.

©2011 Analog Devices, Inc. All rights reserved. Trademarks and registered trademarks are the property of their respective owners.
CN09740-0-8/11(0)



www.analog.com

Rev. 0 | Page 9 of 9

www.BDTIC.com/ADI