

DESIGN NOTES

C-Load™ Op Amps Conquer Instabilities – Design Note 107

Kevin R. Hoskins

Introduction

Linear Technology Corporation has taken advantage of advances in process technology and circuit innovations to create a series of C-Load operational amplifiers that are tolerant of capacitive loading, including the ultimate, amplifiers that remain stable driving any capacitive load. This series of amplifiers has a bandwidth that ranges from 160kHz to 140MHz. These amplifiers are appropriate for a wide range of applications from coaxial cable drivers to analog-to-digital converter (ADC) input buffer/amplifiers.

Driving ADCs

Most contemporary ADCs incorporate a sample-and-hold (S/H). A typical S/H circuit is shown in Figure 1. The hold capacitor's (C1) size varies with the ADC's resolution but is generally in the range of 5pF to 20pF, 10pF to 30pF and 10pF to 50pF for 8-, 10- and 12-bit ADCs, respectively.

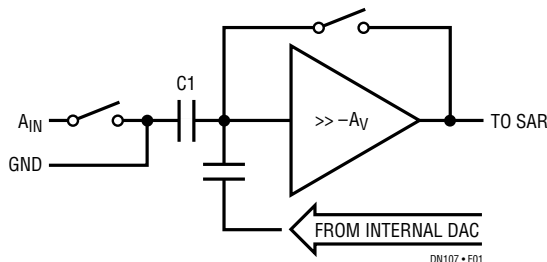

Figure 1. Typical ADC Input Stage Showing Input Capacitors

At the beginning of a conversion cycle, this circuit samples the applied signal's voltage magnitude and stores it on its hold capacitor. Each time the switch opens or closes, the amplifier driving the S/H's input faces a dynamically changing capacitive load. This condition generates current spikes on the input signal. This capacitive load and the spikes produced when they are switched constitutes a very challenging load that can potentially produce instabilities in an amplifier driving the ADC's input. These instabilities make it difficult for an amplifier to quickly settle. If the output of an amplifier has not settled to a value that falls within the

error band of the ADC, conversion errors will result. That is unless the amplifier is designed to gracefully and accurately drive capacitive loads, such as Linear Technology's C-Load line of monolithic amplifiers. Table 1 lists Linear Technology's unconditionally stable voltage feedback C-Load amplifiers. Table 2 lists other voltage feedback C-Load amplifiers that are stable with loads up to 10,000pF.

Table 1. Unity-Gain Stable C-Load Amplifiers Stable with All Capacitive Loads

SINGLES	DUALS	QUADS	GBW (MHz)	I _S /AMP (mA)
—	LT [®] 1368	LT1369	0.16	0.375
LT1200	LT1201	LT1202	11	1
LT1220	—	—	45	8
LT1224	LT1208	LT1209	45	7
LT1354	LT1355	LT1356	12	1
LT1357	LT1358	LT1359	25	2
LT1360	LT1361	LT1362	50	4
LT1363	LT1364	LT1365	70	6

Table 2. Unity-Gain Stable C-Load Amplifiers Stable with C_L ≤ 10,000pF

SINGLES	DUALS	QUADS	GBW (MHz)	I _S /AMP (mA)
LT1012	—	—	0.6	0.4
—	LT1112	LT1114	0.65	0.32
LT1097	—	—	0.7	0.35
—	LT1457	—	2	1.6

Remaining Stable in the Face of Difficult Loads

As can be seen in Figure 2, an amplifier whose design is not optimized for handling a large capacitive load, has some trouble driving the hold capacitor of the LTC[®]1410's S/H. While the LT1006 has other very desirable characteristics such as very low V_{OS}, very low offset drift, and low

LT, LTC and LT are registered trademarks of Linear Technology Corporation. C-Load is a trademark of Linear Technology Corporation.

power dissipation, it has difficulty accurately responding to dynamically changing capacitive loads and the current glitches and transients they produce (as indicated by the instabilities that appear in the lower trace of Figure 2a.

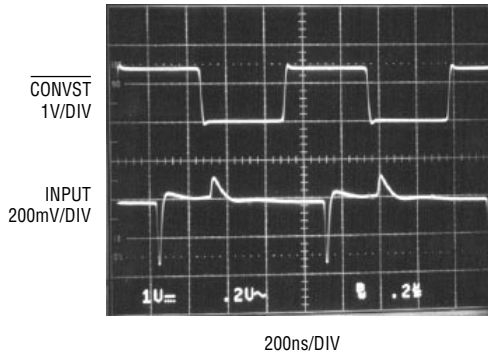

Figure 2a. Input Signal Applied to an LTC1410 Driven by an LT1006

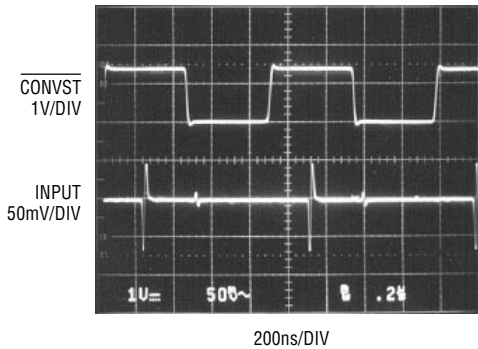

Figure 2b. Input Signal Applied to an LTC1410 Driven by an LT1360

By contrast, Figure 2b shows the LT1360 C-Load op amp driving the same LTC1410 input. The photo shows that the LT1360 is an ideal solution for driving the ADC's input capacitor quickly and cleanly with excellent stability. Its wide 50MHz gain-bandwidth and 800V/ μ s slew rate very adequately complement the LTC1410's 20MHz full power bandwidth. The LT1360 is specified for \pm 5V operation.

Figure 3 shows the circuit used to test the performance of op amps driving the LTC1410's input and measure the input waveforms.

Conclusion

Linear Technology's C-Load amplifiers meet the challenging and difficult capacitive loads of contemporary ADC analog inputs by remaining stable and settling quickly.

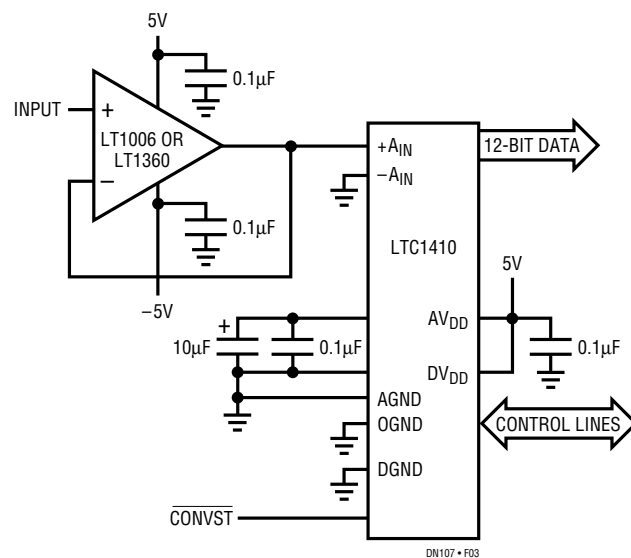

Figure 3. Test Circuit Used to Measure LTC1410 Input Signal Waveform

For literature on our Operational Amplifiers, call **1-800-4-LINEAR**. For applications help, call (408) 432-1900, Ext. 456