

DESIGN NOTES

LT1462/LT1463/LT1464/LT1465: Micropower Dual and Quad JFET Op Amps Feature pA Input Bias Currents and C-Load™ Drive Capability – Design Note 136

Alexander Strong and Kevin R. Hoskins

Introduction

The LT[®]1462/LT1464 duals and the LT1463/LT1465 quads are the first micropower op amps to offer picoampere input bias currents and unity-gain stability when driving capacitive loads. For each amplifier, the LT1462/LT1463 consume only 28 μ A of supply current; the faster LT1464/LT1465, just 145 μ A. Low supply current and operation specified at \pm 5V supplies make these amplifiers appropriate for portable low power applications. The LT1462/3/4/5 family is especially suited for piezo transducer conditioning, strain gauge weight scales, very low droop track-and-holds, wide dynamic range photodiode amplifiers and other applications that benefit from pA input bias current. The LT1462/3/4/5 family also exhibits very low noise current, important to circuits such as low frequency filters. These op amps allow high value resistors to be used with easily obtainable, low value precision capacitors to set a filter's frequency characteristics without compromising noise performance.

Driving Large Capacitive Loads

Though the LT1462/3/4/5 consume very small amounts of supply current, they can easily drive 10nF loads while remaining stable. Instead of increasing their idling current to drive heavy load capacitance, these op amps use a clever compensation technique to lower bandwidth. As load capacitance increases, these op amps automatically reduce their bandwidth by reflecting a portion of the load capacitance back to the gain node, increasing the compensation capacitance. Now instead of a 1MHz op amp trying to drive a large capacitor, a lower bandwidth op amp is able to drive the load capacitance.

Applications

A benefit of the LT1464/LT1465's low power consumption is very low junction leakage current, which in turn, keeps the input bias current below 500fA typically. Track-and-hold applications are a natural for this family of op amps.

LT, LTC and LT are registered trademarks of Linear Technology Corporation. C-Load is a trademark of Linear Technology Corporation.

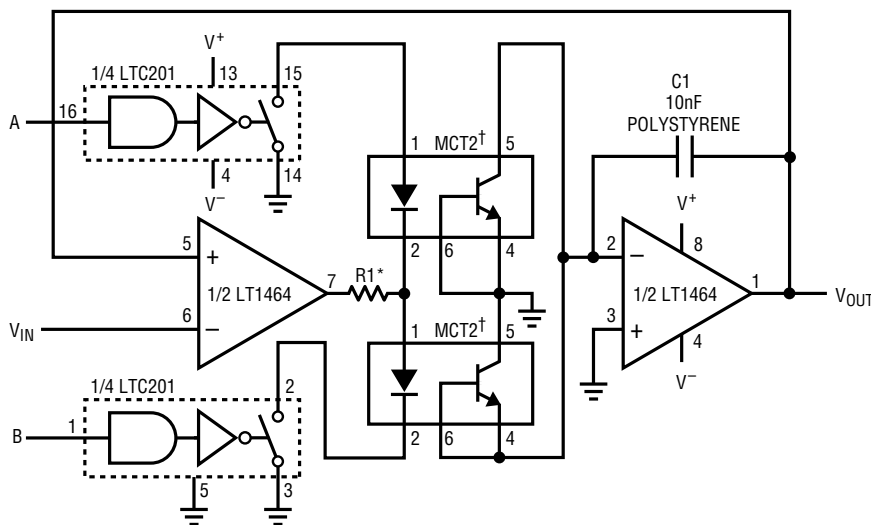

FUNCTION	MODE	IN A	IN B
Track-and-Hold	Track	0	0
	Hold	1	1
Positive Peak Det	Reset	0	0
	Store	0	1
Negative Peak Det	Reset	0	0
	Store	1	0

LTC[®]201 switch is open for logic "1"

$$\text{TYPICAL DROOP} = \frac{0.5\text{pA}}{10\text{nF}} = 0.05\text{mV/s}$$

TOTAL SUPPLY CURRENT = 460 μ A MAX

* R1 = 600 Ω FOR \pm 15V SUPPLIES

R1 = 0 Ω FOR \pm 5V SUPPLIES

† MOTOROLA (602) 244-5768

DN136 F01

Figure 1. Low Droop Track-and-Hold/Peak Detector Circuit Takes Advantage of the LT1464's 0.5pA Input Bias Current

Figure 1 is a track-and-hold circuit that uses a low cost optocoupler as a switch. Leakage for these parts is usually in the nA region with 1V to 5V across the output. Since there is less than 0.8mV across the junctions, the leakage is so small that the op amp's I_B dominates. The input signal is buffered by one op amp while the other buffers the stored voltage; this results in a droop of 50 μ V/s with a 10nF capacitor.

The LT1462/LT1463s low input bias current make it a natural for amplifying low level signals from high impedance transducers. The 1pA input bias current contributes only 0.4fA/ $\sqrt{\text{Hz}}$ of current noise or 0.4nV/ $\sqrt{\text{Hz}}$ voltage noise with a 1M Ω source impedance. A 1M Ω impedance's thermal noise of 130nV/ $\sqrt{\text{Hz}}$ dominates the op amp's noise, showing that even with high source impedances, the LT1462/LT1463 contribute very little to total input-referred noise. Taking advantage of these features, Figure 2's photodiode logging amplifier uses two LT1462 duals or an LT1463 quad. Here, the photodiode current is converted to a voltage by the first op amp and D1 and amplified by the first, second and third logarithmic compression amplifiers.

A DC feedback path comprising R8, R9, C6 and Q1 is active only for no light conditions. Q1 is off when light is present, isolating the photodiode from C6. When feedback is needed, a small filtered current through R8 prevents the op amp outputs from saturating when no signal is present.

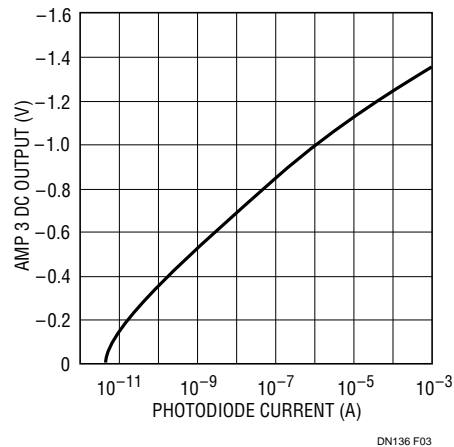

Figure 3. Logging Photodiode Amplifier DC Output

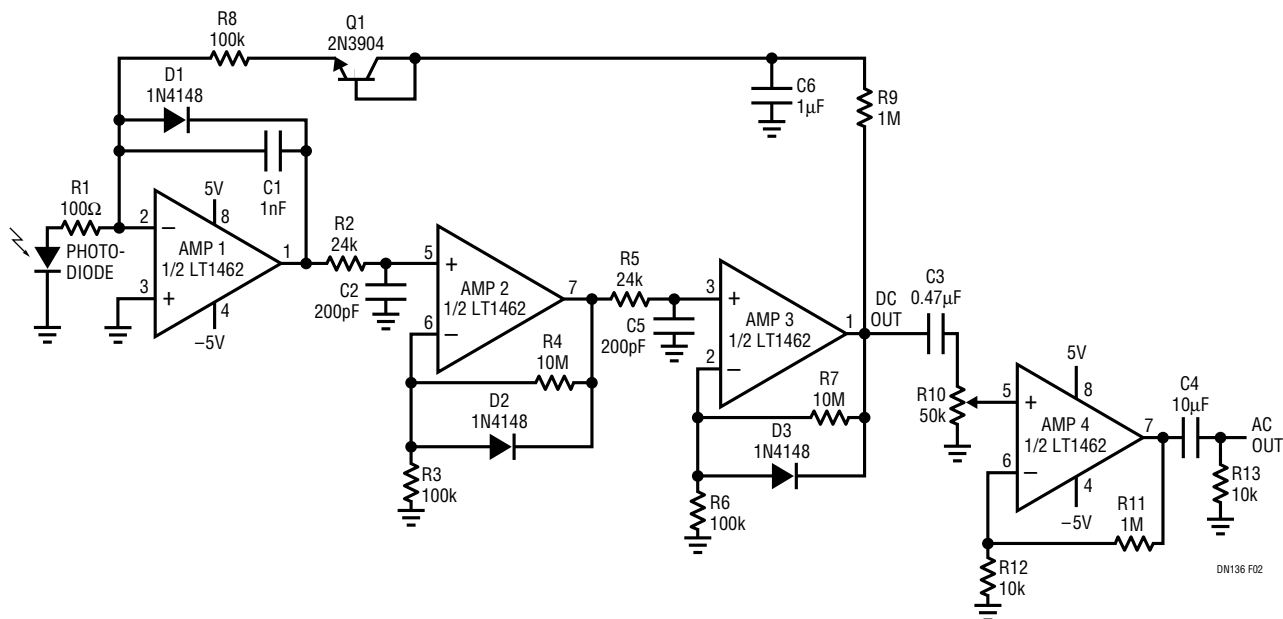

Figure 2. This Logging Photodiode Amplifier Takes Advantage of the LT1462s 1pA Input Bias Current to Amplify the Low Level Signal from the Photodiode's High Source Impedance

For literature on our Operational Amplifiers, call **1-800-4-LINEAR**. For applications help, call (408) 432-1900, Ext. 2593