

# DESIGN NOTES

## LT1511 Low Dropout, Constant-Current/Constant-Voltage 3A Battery Charger – Design Note 144

Chiawei Liao

### Introduction

The LT<sup>®</sup>1511 current mode PWM battery charger is the simplest, most efficient solution for fast charging modern rechargeable batteries that require constant-current and/or constant-voltage charging including lithium-ion (Li-Ion), nickel-metal-hydride (NiMH) and nickel-cadmium (NiCd).

### Higher Duty Cycle for the LT1511 Battery Charger

Maximum duty cycle for the LT1511 constant-current/constant-voltage battery charger is typically 90%, but this may be too low for some applications. For example, if an

18V  $\pm$ 3% adapter is used to charge ten NiMH cells, the charger must put out 15V maximum. A total of 1.6V is lost in the input diode, switch resistance, inductor resistance and parasitics, so the required duty cycle is  $15/16.4 = 91.4\%$ . As it turns out, duty cycle can be extended to 93% by restricting boost voltage to 5V instead of using  $V_{BAT}$ , as is normally done. This lower boost voltage also reduces power dissipation in the LT1511. Connect an external source of 3V to 6V at the  $V_X$  node in Figure 1 with a 10 $\mu$ F  $C_X$  bypass capacitor.

### Enhancing Dropout Voltage

For even lower dropout and/or to reduce heat on the board, the input diode can be replaced with a FET (see Figure 2). It is straightforward to connect a P-channel FET across the input diode and connect its gate to the battery so that the FET commutates off when the input goes low. The problem is that the gate must be pumped low so that the FET is fully turned on even when the input is only a volt or two above the battery voltage. There is also a turnoff speed issue. To avoid large current surges from the battery back through the charger into the FET, the FET should turn off instantly when the input is dead shorted.

LT, LTC and LT are registered trademarks of Linear Technology Corporation.

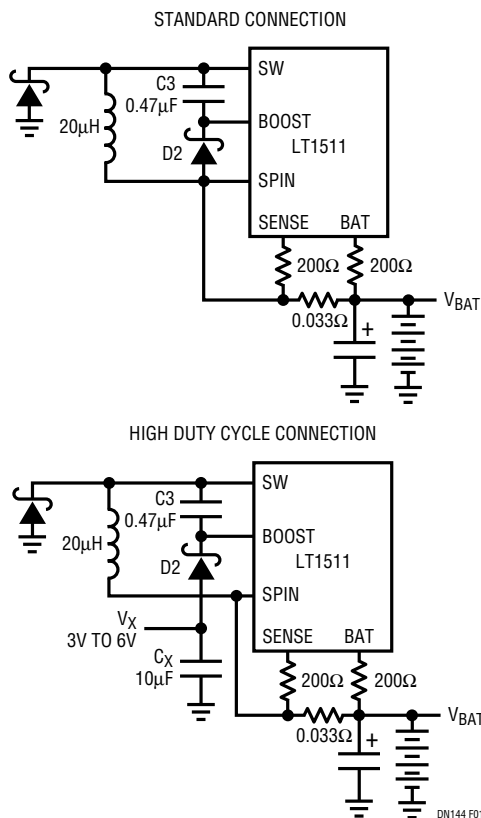
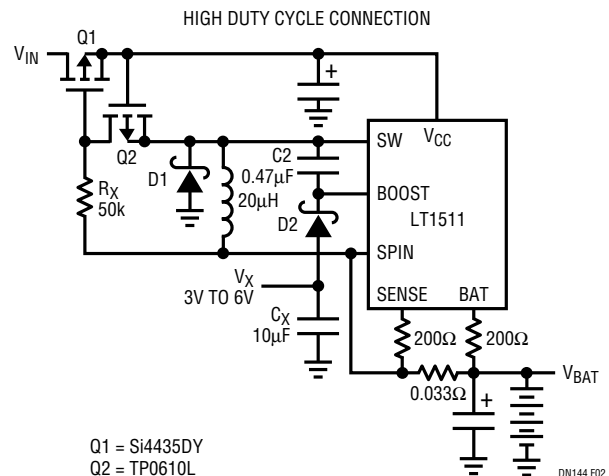

Figure 1. High Duty Cycle



Q1 = Si4435DY  
Q2 = TP0610L

Figure 2. Replacing the Input Diode

Gate capacitance slows turnoff, so a small P-channel (Q2) is used to discharge the gate capacitance quickly in the event of an input short. The body diode of Q2 creates the necessary pumping action to keep the gate of Q1 low during normal operation. Note the Q1 and Q2 have a  $V_{GS}$  spec limit of 20V. This restricts  $V_{IN}$  to a maximum of 20V.

Figure 3 is a 3A complete constant-current/constant-voltage charger for 15V batteries. Input is from an 18V  $\pm 3\%$  adapter. For adapter current limit and undervoltage lockout functions, please see the LT1511 data sheet.

For  $V_{IN} > 20V$ , the circuit in Figure 4 can be used to clamp  $V_{GS}$  to  $< 20V$ .  $R_{X1}$  and  $R_{X2}$  are chosen to draw 1mA or less to ensure that the 2.5V on PROG is sufficient to turn Q2 on. This gives a value for  $R_{X1}$  of about 6.2k and  $R_{X2}$  is calculated from:

$$R_{X2} = R_{X1} \left( \frac{V_{BAT}}{V_{GS} - V_{IN} + V_{BAT}} - 1 \right)$$

$V_{BAT}$  = Highest battery voltage

$V_{GS}$  = Minimum Q1 gate drive

$V_{IN}$  = Lowest input voltage

If  $R_{X1} = 6.2k$ ,  $V_{BAT} = 19.5V$ ,  $V_{GS} = 7V$ ,  $V_{IN} = 21.5V$ ,

Then  $R_{X2} = 18k$

Note: Figure 1, 2 and 4 circuits are for 3A charging current. See the LT1511 data sheet for other design values.

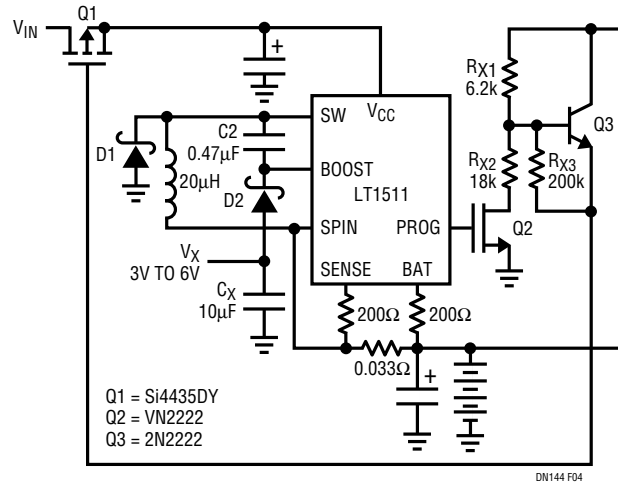

Figure 4.  $V_{IN} > 20V$  Low Dropout Charger

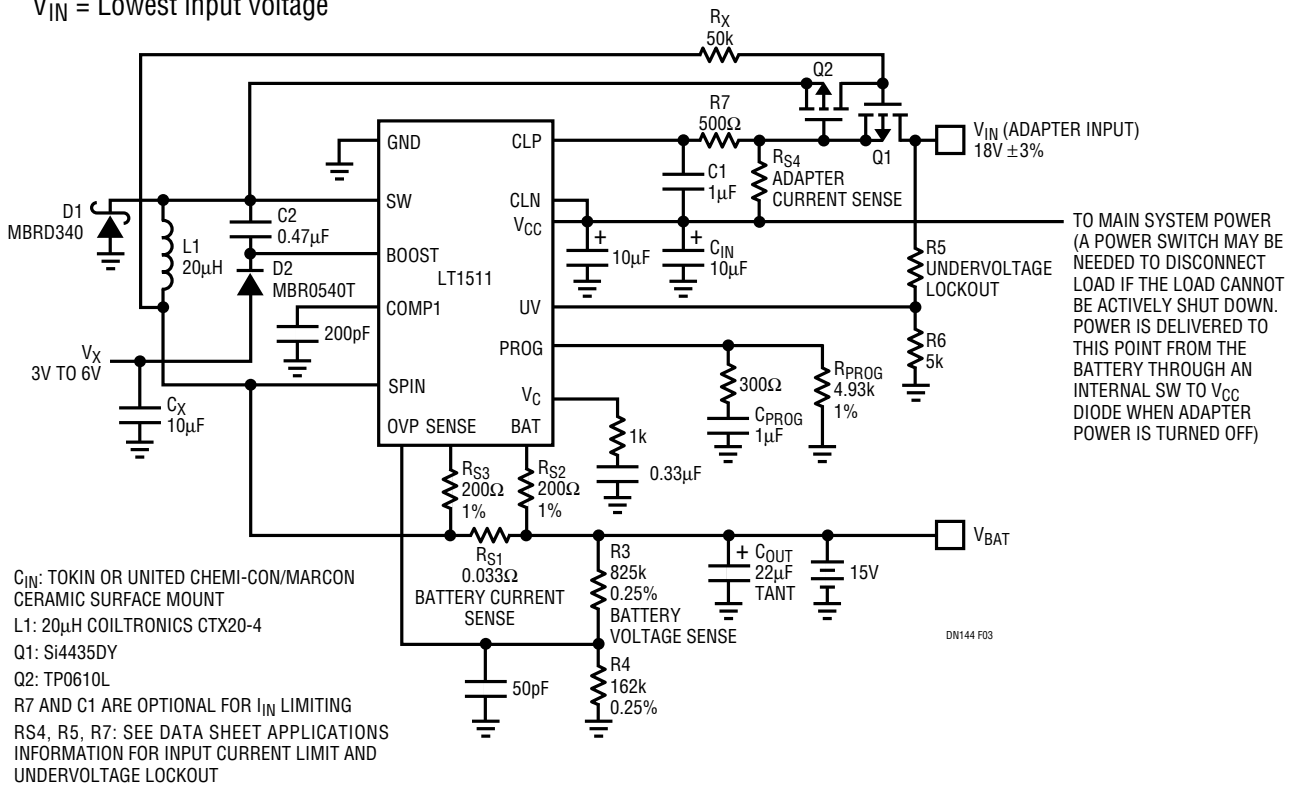

Figure 3. 3A Constant-Current/Constant-Voltage Low Dropout Battery Charger

For literature on our Battery Chargers, call **1-800-4-LINEAR**. For applications help, call (408) 432-1900, Ext. 2360