

DESIGN NOTES

UltraFast Linear Regulator Eliminates All Bulk Tantalum and Electrolytic Output Capacitors

Design Note 157

Anthony Bonte

Introduction

Powering 200+MHz microprocessors requires high current, tight tolerance, fast transient response power supplies. Fast load transients mandate bulk output capacitance to maintain regulation and thus, cost increases. Surface mount tantalum capacitors are expensive and require voltage derating for reliable performance. Electrolytic capacitors are physically large and exhibit increased ESR with age. Therefore, transient response and regulation performance degrade.

To improve profit margins, some manufacturers reduce output capacitance and ignore the true regulation requirements. Many power supplies are deemed reliable if Windows® 95 boots up more than once. Most motherboards are only warranted for 90 days. LTC believes that many system crashes (blamed on software) are attributable to poor power supply regulation. To address these issues, Linear Technology introduces the LT®1575/LT1577.

New LTC Regulator Controllers

The LT1575/LT1577 family of controller ICs drives discrete N-channel MOSFETs and produces low dropout, UltraFast™ transient response regulators. These ICs feature 1% typical performance over all DC tolerances. **Superior transient load performance eliminates all bulk output capacitors.** An LT1577 based P55C Pentium® processor power supply operates with only twenty-four high frequency decoupling, 1µF ceramic capacitors required for the microprocessor core.

Adjustable and fixed voltage versions accommodate any microprocessor voltage. MOSFET $R_{DS(ON)}$ selection allows custom dropout voltage performance. The controllers also provide current limiting, on/off control and overvoltage protection or thermal shutdown. The single LT1575 package is an 8-pin SO or PDIP and the dual LT1577 package is a 16-pin narrow body SO.

Figure 1 illustrates an LT1577 application with a fixed 3.3V and an adjustable voltage regulator for a P54C/P55C Pentium processor autoselect circuit. The P54C Pentium processor core and I/O circuitry operate from 3.5V. The P55C Pentium processor I/O operates from 3.3V and the core operates from 2.8V.

V_{CC2DET} 's signal determines circuit operation. In a P54C circuit, V_{CC2DET} is open and the core and I/O supply planes

LT, LTC and LT are registered trademarks of Linear Technology Corporation. UltraFast is a trademark of Linear Technology Corporation. Windows is a registered trademark of Microsoft Corporation. Pentium is a registered trademark of Intel Corporation.

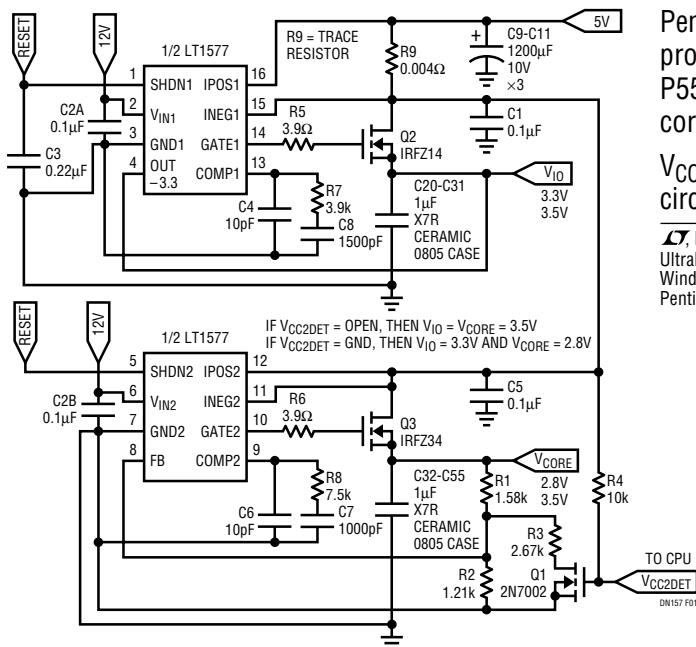

Figure 1. LT1577 P54C/P55C Pentium Processor Autoselect Circuit

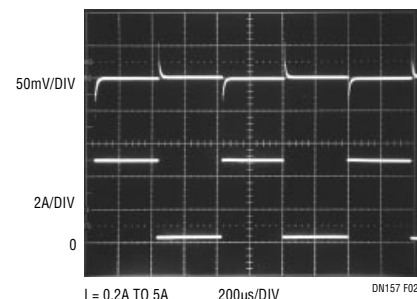

Figure 2. Transient Response for 0.2A to 5A Output Load Step

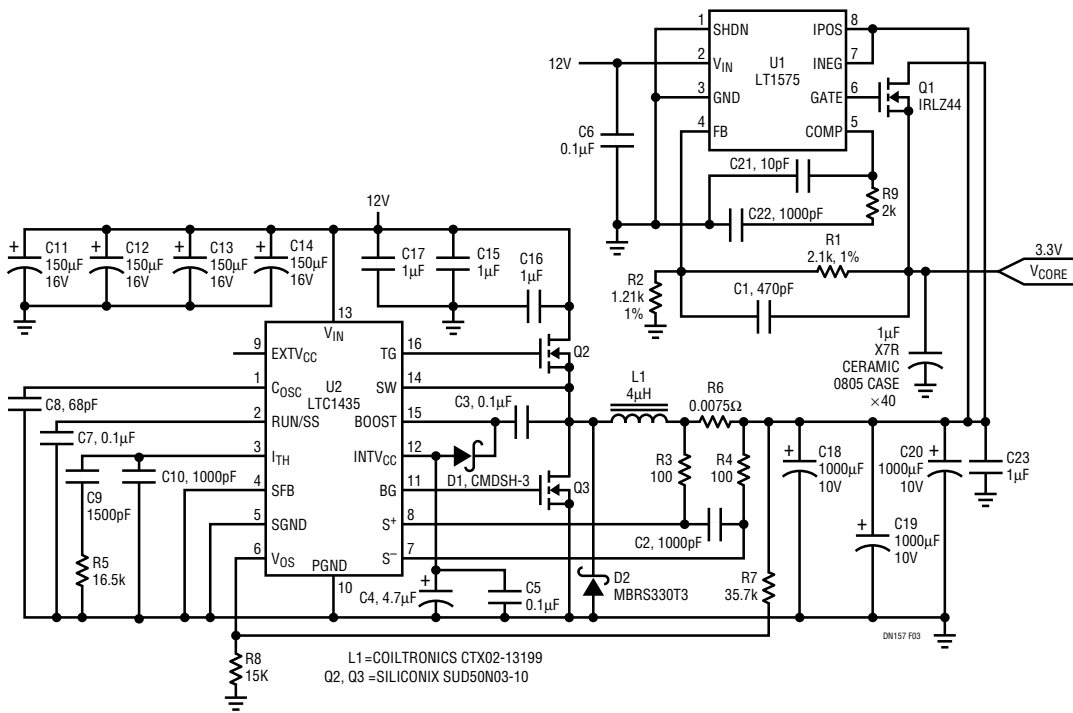

Figure 3. 12V to 3.3V/9A (14A Peak) Hybrid Regulator

connect together. Q1 turns on and the Q3 (IRFZ34) regulator controls its output to 3.5V. The Q2 (IRFZ14) regulator attempts to control its output to 3.3V, but its feedback pin (Pin 4) senses 3.5V and turns Q2 off. Q3 supplies all core and I/O power.

In a P55C circuit, V_{CC2DET} is grounded and the core and I/O supply planes are separate. Q2 controls the I/O voltage to 3.3V and Q3 controls the core voltage to 2.8V. The I/O circuitry's lower current requirement permits a lower cost MOSFET for Q2 and reduced output capacitance.

The current limit sense resistor is made of "free" PCB trace. Q2's and Q3's common-drain connection permits common heat sink mounting. The COMP pin components adjust frequency compensation for each regulator relative to the MOSFET and output capacitors used.

Figure 2 shows the core regulator transient response for a 4.8A load current step in a P55C setup. Compensation limits overshoot/undershoot to 50mV. The $\pm 100mV$ tolerance for a VRE processor is easily met. The autoselect concept is easily extended to the multiplicity of voltages required by various processors. Consult LTC for details.

Figure 3 shows a 3.3V, 14A logic supply that uses an LT1575 as a post-regulator on an LTC[®]1435 synchronous buck regulator, generating 3.3V from 12V with an overall efficiency of 72%. The LT1575 uses an IRLZ44 as the pass transistor, allowing < 550mV dropout voltage. The switching regulator's output is set to 4V.

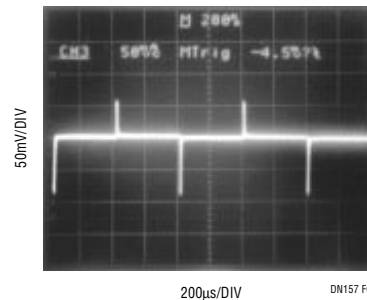

Figure 4. Transient Response for Figure 3's Circuit to a 10A Load Step

Figure 4 shows the transient response for a 10A, 50ns rise/fall time load step. The only output capacitors are 40, μF surface mount ceramic capacitors. The circuit eliminates about a dozen low ESR tantalum capacitors, which would be required without the linear regulator.

Conclusion

The LT1575/LT1577 combine the benefits of low dropout voltage, precision performance, UltraFast transient response and significant output capacitance cost savings. The LT1575/LT1577 controller ICs step to the next performance level required by motherboard designers.

For literature on our Linear Regulators, call **1-800-4-LINEAR**. For applications help, call (408) 432-1900, Ext. 2360