

DESIGN NOTES

Resolving Very Small Temperature Differences with the LTC2402

Design Note 257

Derek Redmayne

The LTC[®]2402, a 2-channel 24-bit, No Latency Delta-Sigma[™] ADC, is well-suited to differential temperature sensing using a number of different sensors. Extremely good matching between channels allows two absolute temperature measurements to be compared in order to determine the differential or gradient between two points. In the circuits shown below, the LTC2402, with averaging, can resolve a temperature differential of a few millidegrees, although in the case of a single-shot pair of readings, a peak error of 0.05°C is possible. Independently adjustable full-scale (FS_{SET}) and zero-scale (ZS_{SET}) facilitate 3- or 4-wire measurements with platinum RTDs and the automatic sequencing of the two channels makes measurements across an isolation barrier easier. The no latency feature of these ADCs also resolves dilemmas associated with pulsed excitation. The use of pulsed excitation minimizes or eliminates parasitic thermocouple effects that can compromise RTD measurements. In addition, pulsed excitation can reduce standby or average power consumption in battery-powered applications.

Platinum RTDs

Platinum RTDs are the most stable and accurate temperature sensors available on the market. However, their low output levels and self-heating effects require attention to detail in both physical placement and electrical design. RTDs, although more linear than thermocouples and thermistors, are somewhat nonlinear; linearization should therefore be used. In the past, this has often been done in a first-order approximation by feeding back a portion of the amplified output voltage to the excitation, thereby providing a multiplication factor. With a processor-driven design, hardware linearization is unnecessary.

Self-Heating Effects

The self-heating effect that results from the excitation current is dependent on the thermal resistance of the RTD element to its environment. If this thermal resistance is a constant (as it would be if the sensor is bonded to a solid mass), the self-heating effect can be calculated

based on the resistance of the RTD at temperature, then subtracted from the reading. This assumes that the ambient medium undergoes no phase changes in the temperature range of interest. For absolute temperature measurements, self-heating effects can be problematic; however, if temperature differential is the issue, the use of a higher excitation current can be an advantage. If the thermal resistance of the two sensors to their local environment matches reasonably well, the self-heating effect will have an effect on the absolute measurement only. The absolute temperature measurement is needed only for purposes of determining the slope of the resistance change, and hence is not very critical, possibly eliminating the need for precise linearization.

At a rather high excitation current of 1mA, a 100Ω RTD (European curve) will produce 385μV/°C of output signal in the neighborhood of 25°C (290μV/°C at 850°C). Averaging thirty readings will resolve the temperature differential to a couple of millidegrees, although a single channel reading will exhibit approximately 0.05°C peak-to-peak noise.

Bridge Connection of RTDs

Figure 1 shows the use of the two channels of the LTC2402 to sense two RTDs in essentially the same manner. If the two sensors are physically close together,

LT, LTC and LT are registered trademarks of Linear Technology Corporation. No Latency Delta-Sigma is a trademark of Linear Technology Corporation.

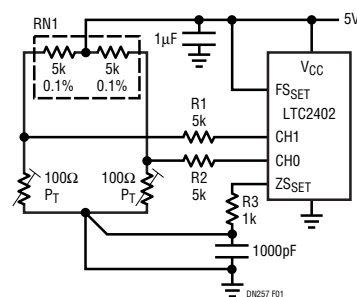

Figure 1. 2-Channel ADC Measures Differential Temperature from Bridge Configured RTDs, ZS_{SET} Input Eliminates Drop in Connecting Wire

remote sensing of the common return by virtue of the connection to Z_{SSET} eliminates the effect of the voltage drop across the return wiring. The wiring leading to the upper terminal of the sensors is only responsible for a small gain error. For example, 20 feet of 26-gauge copper wire would only produce 0.068% gain error (in contrast, if remote sensing of the common return were not used, the error associated with individual returns would be approximately 20°C).

The tolerance of the two reference resistors can contribute a much greater error, by virtue of producing a gain error. One-percent (1%) resistors would produce a gain error of up to 2%, resulting in an error of 5°C. However, the gain error can be recorded and eliminated in software if conditions producing zero temperature gradient can be produced or identified. It is recommended that resistors R1 and R2 be either a matched divider pair or very low temperature coefficient devices such as Vishay S102 or Z201 series. Temperature tracking in integrated pairs can be as tight as 0.1 ppm/°C.

Series Connection of RTDs

Figure 2 shows a means by which the gain variation between the two channels can be reduced. As there is only one excitation current, there is no need for precisely matched resistors. The tolerance of the reference resistor (R4) only significantly affects the absolute measurement and if the quantity that is desired is the differential temperature, the absolute temperature needs only to be known to nominal accuracy. A 5% resistor, in this case, may give adequate results. The only error mechanism,

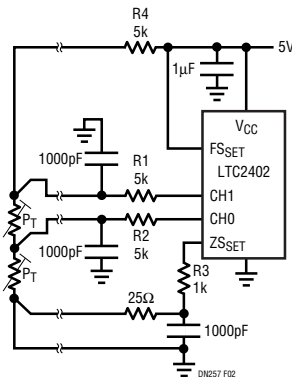

Figure 2. Stacked Half Bridge Eliminates Half the Excitation Current and the Matching Requirements of Figure 1.

Data Sheet Download

<http://www.linear-tech.com/go/dnLTC2402>

other than noise, is nonlinearity in the ADC between the nominal 0mV to 400mV range and the 400mV to 800mV range. As linearity does not exhibit any abrupt discontinuities over the full input range, this is not more than a ppm of full scale over this more restricted range.

Pulsed Excitation

Figure 3 is an example of how pulsed excitation current can be used. When the analog switch (SW1) is turned off, the full reference voltage is still applied to the reference terminal, but there is no appreciable excitation applied to the RTDs. The voltages measured at the inputs are now determined by offset and parasitic thermocouple voltages present in all the connections between the RTD and the ADC. These measurements should be subtracted from the voltages measured with excitation current flowing. Alternation of measurements with and without excitation will suppress 1/f noise, if amplification were introduced to amplify the difference voltage. The amplifier shown within dashed lines is an instrumentation amplifier such as the LT[®]1167. If the amplifier is used, SW3, R6 and R7 must be used to allow signals to remain within the input range of the amplifier.

The use of copper or tungsten RTDs, in conjunction with the LTC2402 and the techniques described above, would allow very subtle temperature gradients to be measured in numerous industrial, consumer or automotive applications.

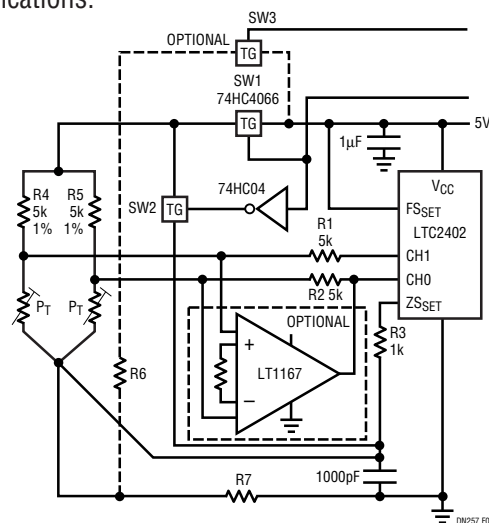

Figure 3. Switched Excitation Reduces Standby Current and Cancels Offset, Thermocouples and Low Frequency Noise

For literature on our No Latency $\Delta\Sigma^{\text{TM}}$ ADCs, call **1-800-4-LINEAR**. For applications help, call (408) 432-1900, Ext. 2453