

DESIGN NOTES

3V Operation of Linear Technology Op Amps – Design Note 56

George Erdi

The latest trend in digital electronics is the introduction of numerous IC's operating on regulated 3V or 3.3V power supplies. This is a logical development to increase circuit densities and to reduce power dissipation. In addition, many systems are directly powered by two AA cells or 3V Lithium batteries. Clearly, analog IC's which work on 3V with good dynamic range to complement these digital circuits are, and will be, in great demand.

Many Linear Technology operational amplifiers work well on a 3V supply. The purpose of this design note is to list these devices and their performance when powered by 3V. The op amps can be divided into two groups: single and dual supply devices. The single supply op amps are optimized for, and fully specified at, a 5V positive supply with the negative supply terminal tied to ground. Input common mode voltage range goes below ground, and the output swings to within a few millivolts of ground while sinking current. Members of the single supply family are the micropower LT1077/LT1078/LT1079 single, dual and quad op amps with 40 μ A

supply current per amplifier, the LT1178/LT1179 dual and quad with 13 μ A per amplifier. The LT1006/LT1013/LT1014 single, dual and quad have faster speed and lower voltage noise, at the expense of 300 μ A per amplifier.

The performance of these devices at 3V is quite similar to the 5V specs. Clearly, input voltage range and output voltage swing have to be reduced by 2V since the supply is 2V less. Offset voltage change from 5V to 3V is determined by the power supply rejection ratio specs. At 114dB or 2 μ V/V the degradation in offset voltage is only 4 μ V (= 2V x 2 μ V/V). Input bias and offset currents, voltage and current noise, as well as offset voltage drift with temperature, are practically unchanged compared to the 5V specifications.

Table I summarizes the performance of the low cost grades of these single supply devices at 3V. One note of caution: the minimum operating voltage for the LT1013/LT1014 is 2.95V. All other devices work on lower supplies, ranging from 1.7V to 2.6V.

Table I. Single Supply Op Amps: Low Cost Grade Specifications $V_S = 3V$, $0V$. $T_A = 25^\circ C$.

| PARAMETER | | LT1077CN8 LT1078CN8 LT1079CN | | LT1178CN8 LT1179CN | | LT1006CN8 LT1013CN8 LT1014CN | | UNITS |
|---------------------------------------|--------------|------------------------------------|---------|-----------------------|---------|------------------------------------|----------|------------|
| | | TYP | MIN/MAX | TYP | MIN/MAX | TYP | MIN/MAX | |
| Offset Voltage | Single | 15 | 80 | — | — | 35 | 95 | μ V |
| | Dual/Quad | 45 | 140/170 | 45 | 140/170 | 95 | 470 | μ V |
| Input Voltage Range | | -0.3 | 0 | -0.3 | 0 | -0.3 | 0 | V |
| | | +1.8 | +1.7 | +1.9 | +1.7 | +1.8 | +1.7 | V |
| Output Swing | No Load | 0.003 | 0.006 | 0.006 | 0.009 | 0.015 | 0.025 | V |
| | | 2.4 | 2.2 | 2.4 | 2.2 | 2.4 | 2.2 | V |
| | 2K to Ground | 0.0006 | 0.0010 | 0.0002 | 0.0006 | 0.007 | 0.015 | V |
| | | 2.1 | 1.9 | 2.0 | 1.8 | 2.3 | 2.0 | V |
| Voltage Gain | $R_L = 50K$ | 500 | 110 | 180 | 60 | 1000 | 500 | V/mV |
| 0.1Hz to 10Hz Noise | | 0.6 | — | 1.0 | — | 0.5 | — | μ Vp-p |
| Minimum Supply Voltage | | — | 2.3 | — | 2.2 | — | 2.6/2.95 | V |
| With 300 μ V V_{OS} Degradation | | — | 1.8 | — | 1.7 | — | — | V |
| Gain Bandwidth Product | | 160 | — | 50 | — | 700 | — | KHz |

The LT1101 micropower ($= 75\mu\text{A}$) instrumentation amplifier completes the single supply family. Again, this in amp in 8 pin packages is fully specified at 5V. Minimum supply voltage is 1.8V; the performance change in going from 5V to 3V supply is minimal.

The second group of devices are dual supply op amps, i.e., the common mode input voltage and the output swing are limited to a diode voltage ($= 600\text{mV}$) above the negative supply terminal for proper operation. In addition, dual supply op amps are traditionally optimized for $\pm 15\text{V}$ operation. Thus, reducing the total supply voltage to 3V represents a significant change. Table II lists the performance of four op amps: the LT1008 and LT1012 are actually fully tested at reduced supplies. The LT1097 and LT1001 performance is inferred from device evaluation data. Dual versions in 14 pin packages are also available: the LT1002 is a dual LT1001; the LT1024 is a dual version of the LT1012.

In most 3V applications the single supply op amps of Table I are more flexible and desirable, since no special biasing is needed to shift the input and the output into the operating range. However, the offset voltage drift with temperature performance of the dual supply devices is better. And, most importantly, when pico-ampere input bias currents are needed, the LT1008/LT1012/LT1097 have no competition. The op amps of

Table I are all at least 6nA. The traditional ways of achieving pico-ampere bias current are not available either: JFET input or CMOS chopper-stabilized op amps do not function at 3V supply.

Figure 1 shows an application using the LT1078 to monitor the condition of the 3V battery. One output warns that the battery voltage is dropping, the other output shuts the system down as the battery voltage falls below the threshold value.

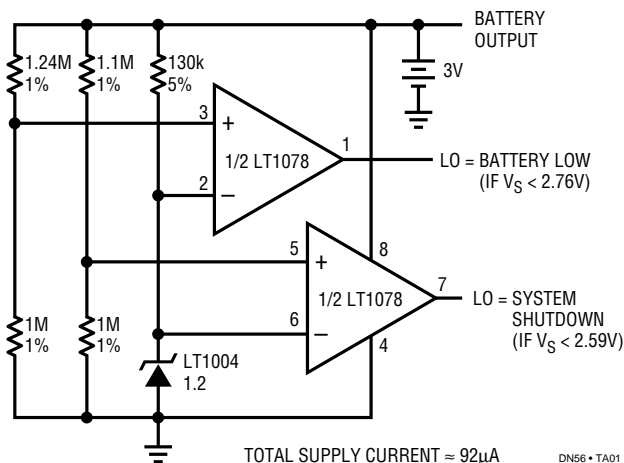

Figure 1. Low Battery Detector with System Shutdown

Table II. Dual Supply Op Amps at $V_S = 3\text{V}$, 0V . $T_A = 25^\circ\text{C}$. Low Cost Grade Electrical Characteristics.

| PARAMETER | LT1097CN8 | | LT1008CN8 | | LT1012CN8 | | LT1001CN8 | | UNITS |
|---------------------------------|-----------|---------|-----------|---------|-----------|---------|-----------|---------|------------------------------|
| | TYP | MIN/MAX | TYP | MIN/MAX | TYP | MIN/MAX | TYP | MIN/MAX | |
| Offset Voltage | 20 | 100 | 40 | 180 | 25 | 120 | 40 | 150 | μV |
| Drift with Temperature | 0.3 | 1.3 | 0.3 | 1.6 | 0.3 | 1.3 | 0.3 | 1.3 | $\mu\text{V}/^\circ\text{C}$ |
| Input Bias Current | 40 | 280 | 40 | 150 | 40 | 200 | 600 | 3500 | pA |
| Input Offset Current | 40 | 260 | 30 | 150 | 30 | 200 | 350 | 3200 | pA |
| Input Voltage Range | 0.65 | 0.80 | 0.65 | 0.80 | 0.65 | 0.80 | 0.75 | 0.90 | V |
| | 2.3 | 2.2 | 2.3 | 2.2 | 2.3 | 2.2 | 2.2 | 2.1 | V |
| Output Swing | 0.62 | 0.8 | 0.62 | 0.8 | 0.62 | 0.8 | 0.55 | 0.7 | V |
| | 2.25 | 2.1 | 2.25 | 2.1 | 2.25 | 2.1 | 2.2 | 2.05 | V |
| Voltage Gain $R_L = 10\text{K}$ | 600 | 250 | 500 | 200 | 500 | 200 | 300 | 150 | V/mV |
| 0.1Hz to 10Hz Noise | 0.5 | — | 0.5 | — | 0.5 | — | 0.35 | — | $\mu\text{Vp-p}$ |
| Minimum Supply Voltage | — | 2.4 | — | 2.4 | — | 2.4 | — | 1.9 | V |
| Supply Current | 350 | 560 | 380 | 600 | 380 | 600 | 390 | 550 | μA |
| Gain Bandwidth Product | 500 | — | 500 | — | 500 | — | 600 | — | KHz |

For literature on our Single Supply, Micropower, and Precision Op Amps, call **(800) 637-5545**. For applications help, call (408) 432-1900, Ext. 361