

# DESIGN NOTES

## Regulator Circuit Generates Both 3.3V and 5V Outputs from 3.3V or 5V to Run Computers and RS232 – Design Note 71

David Dinsmore and Richard Markell

Many portable microprocessor-based systems use a mix of 3.3V and 5V circuits. Some are still using only 5V and inevitably some systems will end up being solely 3.3V based. If accessories are to be plugged into, or connected to any of these systems, a voltage conversion/power generation problem presents itself. The circuit shown in Figure 1 addresses the situation where *either* 5V or 3.3V power is available from the bus, but the accessory needs *both* 5V and 3.3V power.

The circuit consists of two sections, one being a DC/DC converter and the other being a pair of dual N-channel MOSFETs and their associated high-side drivers that effectively form a DPDT switch.

When first powered up, a comparator inside of the LT1111 (IC2) determines the state of the circuit. The comparator's output (IC2, pin 6) is wired to the input of the LTC1157

MOSFET driver (IC1). The LTC1157 internally generates a gate drive voltage which is 8.8V above the supply voltage and efficiently turns on and off the appropriate MOSFETs.

IC2 also forms a flying capacitor buck/boost DC/DC converter circuit. This topology is used so that no transformers are necessary. Q1 is used to control this section's voltage ( $V_1$ ). When  $V_{IN}$  is at 5V, Q1 is off, forcing this section to operate as a step-down converter. It produces 3.3V which is sent to the 3.3V output of the circuit through IC4B. In this state, 5V power is sent directly through IC3A while IC3B and IC4A are off.

When  $V_{IN}$  is at 3.3V, IC1 turns on Q1 shorting out the 140k resistor and forcing the DC/DC converter into step-up mode so that it generates 5V at  $V_1$  which is sent to the 5V output through IC3B, while 3.3V power is sent from input to output through IC4A. IC3A and IC4B are off.

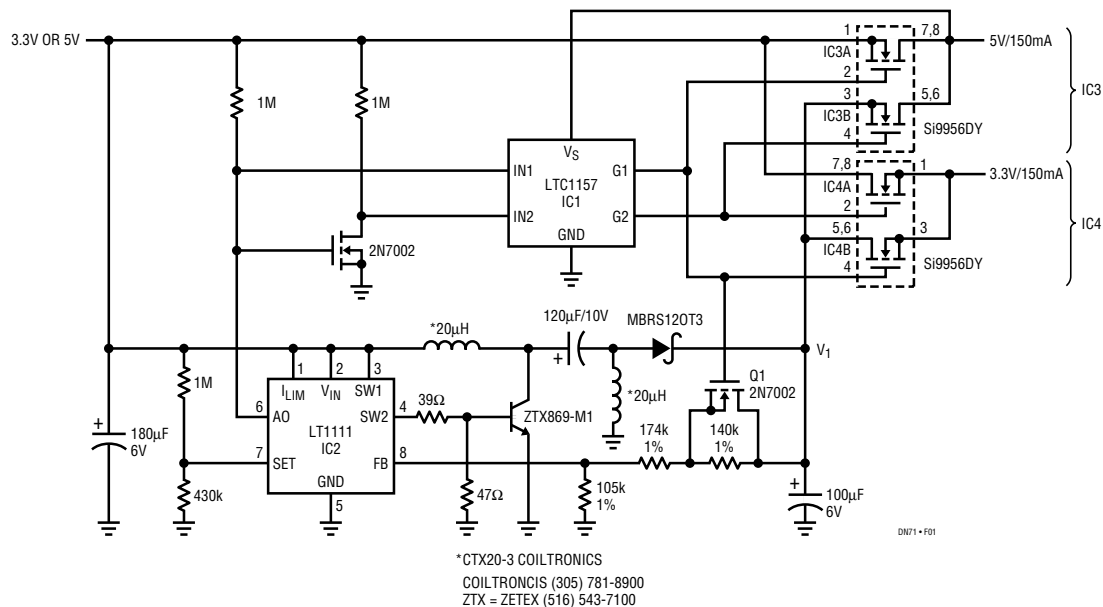

Figure 1.

No load quiescent current is about 500µA. By replacing the LT1111 with the lower frequency LT1173 this could be reduced to 315µA, at the expense of a larger inductor size.

Overall efficiency of the circuit exceeds 80% with  $V_{IN} = 3.3V$  and 86% with  $V_{IN} = 5V$ . All components are available in surface mount.

### Mixed 3.3V and 5V RS232 Operation

Portable computers also require RS232 interfacing circuitry for inter-computer and mouse interfacing applications. Most portable computers now use a mix of 3.3V and 5V logic. Linear Technology offers a wide variety of interfacing circuits that can, not only work with these voltages, but upgrade to single 3.3V supplies when that is required.

Figure 2 shows the LT1330, a 3-driver/5-receiver, PC compatible, RS232 interface running on both 3.3V and 5V supplies. The LT1330's charge pump power is taken from the 5V supplies maximizing the RS232 transmitters load driving capability. The center trace of the photo demonstrates the ability of the transmitters to drive a 3000Ω/2500pF load at 120k Baud. The drive level shown here are -6V to 7V when fully loaded.

The LT1330's receivers are powered by the 3.3V supply on pin 14. This allows the logic levels to be compatible with either TTL or 3.3V logic since the output logic levels are typically 0.2V to 2.7V. Logic inputs to the transmitters respond to TTL levels, so they can be driven from either 3.3V or 5V logic families.

When the entire system can be operated on 3.3V, an LT1331 may be directly substituted for the LT1330. The LT1331 can be operated at 120k Baud with the only limitation being transmitter output levels are -3.5V to 4V. While these levels are not RS232 compliant, they can be used to interface with all known RS232/RS562 systems. In all cases the LT1331 operated at 3.3V would provide a reliable communications link. The table below shows the details of 3-driver/5-receiver RS232 transceivers for 3.3V and mixed 5V/3.3V systems.

	LT1342	LT1330	LT1331	LT1327
ESD Protection	±10kV	±10kV	±10kV	±10kV
3V Logic Interface	✓	✓	✓	✓
Power Supply	3V/5V	3V/5V	3V, 5V or 3V/5V	3V
Supply Current in SHUTDOWN	1µA	60µA	60µA	1µA
Receiver Active in SHUTDOWN		✓	✓	
Driver Disable	✓	✓	✓	
External Capacitors	0.1, 0.2µF	0.1, 0.2, 1µF	0.1, 0.2µF	0.1µF
Rx Output (Typ)	0.2V-2.7V	0.2V-2.7V	0.2V-2.7V	0V-3.3V
RS232 Tx Compliant	✓	✓		
RS232 Tx Compatible	✓	✓	✓	✓

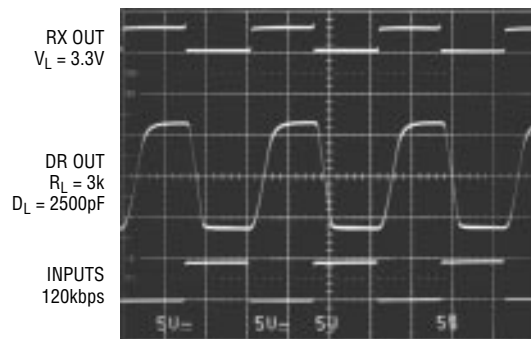
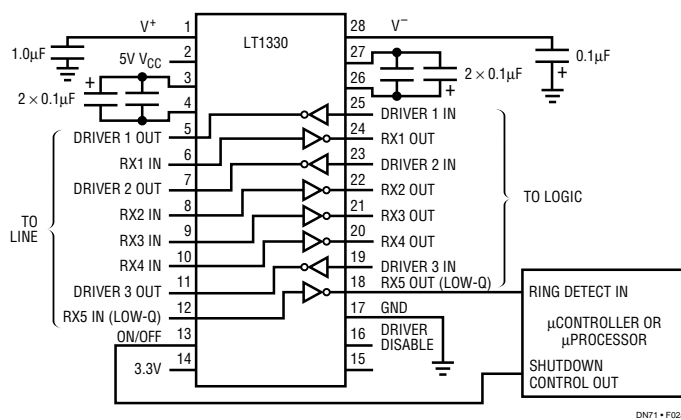

Figure 2. LT1330 Mixed 5V/3V Operation

For literature on our Interface products, call (800) 637-5545. For applications help, call (408) 432-1900, Ext. 453