



# DESIGN NOTES

Number 9 in a series from Linear Technology Corporation

March, 1988

## Chopper Amplifiers Complement a DC Accurate Low-Pass Filter

Nello Sevastopoulos

Monolithic switched-capacitor low-pass filters, although they offer precise frequency responses, cannot usually be used for DC accurate applications because of their prohibitive DC offsets and poor gain linearity. The LTC1062, however, is quite different from currently available low-pass switched-capacitor filters because it uses an external (R, C) to isolate the IC from the input-signal DC path and to provide antialiasing for incoming signals larger than half its clock frequency. The LTC1062 is ideal when used in conjunction with high performance chopper-stabilized op amps.

The LTC1050 is an ultra low offset, low noise chopper with the sampling capacitors internal. It can remove residual clock noise without adding further DC error. Also, the internal capacitor minimizes board area.

Figure 1 shows a low cost, 7th order DC accurate, 10Hz low-pass filter where amplitude and phase response closely ap-

proximates a Bessel filter. The required clock frequency is 2kHz, thus yielding a clock to cutoff frequency ratio of 200:1.

The LTC1050 is configured as unity gain 2nd order low-pass filter which center frequency is  $(1.2\pi R'C') = 1.72 \times f_{\text{CUT-OFF}} = 17.2\text{Hz}$  and  $Q = 0.5$ . Figure 2 shows the amplitude response of the filter, and Figure 3 shows a well behaved transient response for which Bessel filters are famous. The power supplies used were  $\pm 8\text{V}$  to provide a total DC input common-mode range of  $\pm 6\text{V}$ . The measured wideband noise was  $52\mu\text{Vrms}$ . The clock, and R, C values of Figure 1 can be easily modified to provide a 7th order Butterworth 10Hz filter, such as:  $f_{\text{CLK}} = 1\text{kHz}$ ,  $R = 26.7\text{k}$ ,  $C = 1\mu\text{F}$ ,  $R' = 165\text{k}$ ,  $C1 = 0.2\mu\text{F}$  and  $C2 = 0.047\mu\text{F}$ . The diode at LTC1062 pin 3 should be used to protect the device from incoming signals above the power supplies.

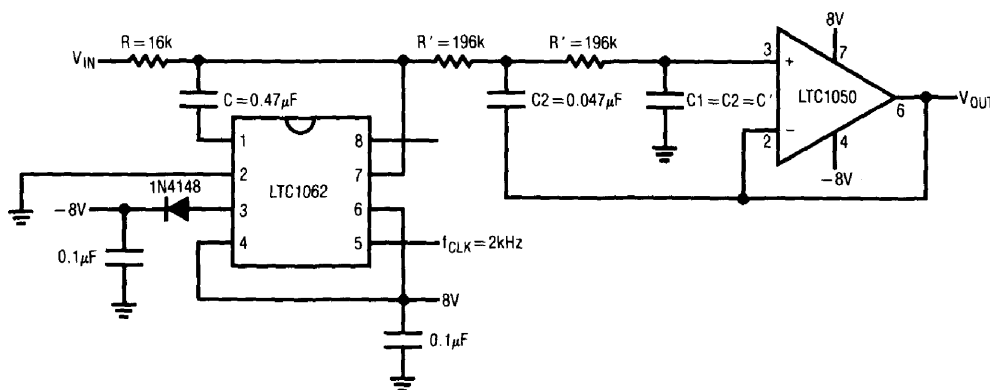

Figure 1. Combining the LTC1050 Chopper Op Amp with the LTC1062 to Provide a 10Hz, DC Accurate Low-Pass Bessel Filter

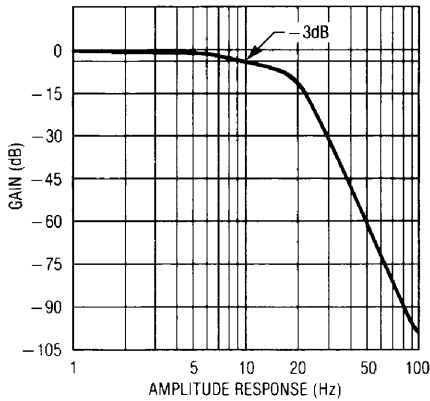

Figure 2. Amplitude Response of Figure 1, Providing a Close Approximation to a Bessel Filter

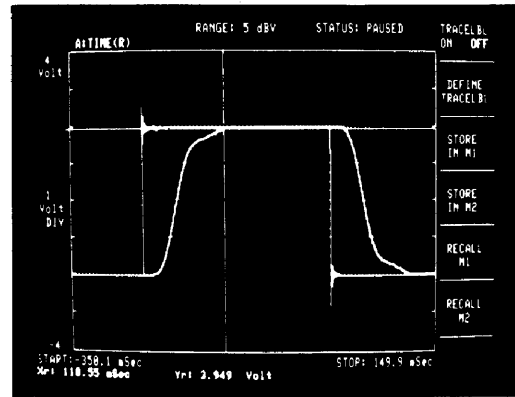

Figure 3. Transient Response of the Bessel Low-Pass Filter of Figure 1

In Figure 4, an external (R1, R2, C1) network is used at the input-output of the internal buffer of the LTC1062 (pins 7 and 8), to provide an additional 2 pole,  $Q = 0.707$ , high-pass filter. The filter output at pin 8 is bandpass, Figure 5, whereas the DC accurate Butterworth low-pass filter is still available at the output of the LTC1050. This circuit allows the user to separate the DC and AC components of an incoming signal,  $V_{IN}$ . Here, the LTC1050 buffers the low-pass filter section of the overall bandpass filter. For a  $Q = 0.707$ , the design equation for the high-pass sections are straightforward: set  $R2 = 2R1$ ;

and then the high-pass cutoff frequency is,  $f_c = (0.707 / 2\pi R1 C1)$ . The circuit in Figure 4 can be easily operated with a single supply, because resistor R2 and capacitor(s) C1 of the high-pass section, also DC bias pin 7 at mid supplies independently of the DC input voltage. If only a single supply is available, simply bias the bottom side of R2 at half supply.

For Filter literature call 800-637-5545. For help with an application call (408) 432-1900, Ext. 361.

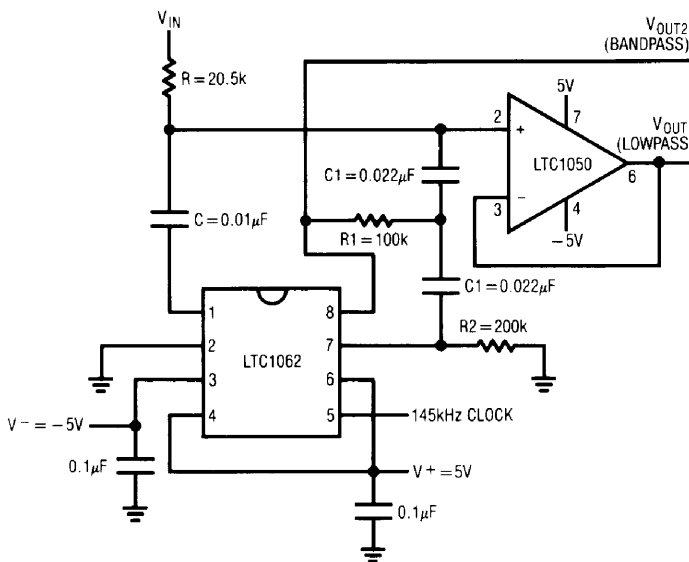

Figure 4. A Bandpass, DC Accurate Lowpass Filter Combination used to Extract the AC Information from a DC + AC Input Signal

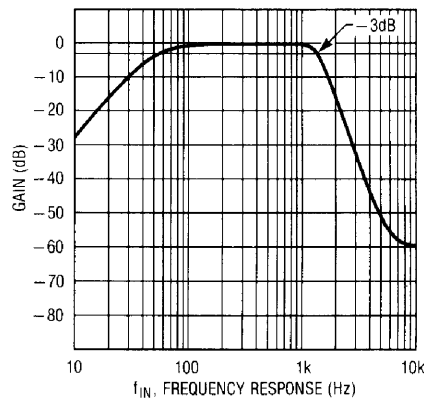

Figure 5. Frequency Response of the Bandpass Filter Output,  $V_{OUT2}$ , of Figure 4