

32Mb B-die Page NOR Specification

INFORMATION IN THIS DOCUMENT IS PROVIDED IN RELATION TO SAMSUNG PRODUCTS, AND IS SUBJECT TO CHANGE WITHOUT NOTICE.

NOTHING IN THIS DOCUMENT SHALL BE CONSTRUED AS GRANTING ANY LICENSE, EXPRESS OR IMPLIED, BY ESTOPPEL OR OTHERWISE,

TO ANY INTELLECTUAL PROPERTY RIGHTS IN SAMSUNG PRODUCTS OR TECHNOLOGY. ALL INFORMATION IN THIS DOCUMENT IS PROVIDED

ON AS "AS IS" BASIS WITHOUT GUARANTEE OR WARRANTY OF ANY KIND.

1. For updates or additional information about Samsung products, contact your nearest Samsung office.
2. Samsung products are not intended for use in life support, critical care, medical, safety equipment, or similar applications where Product failure could result in loss of life or personal or physical harm, or any military or defense application, or any governmental procurement to which special terms or provisions may apply.

* Samsung Electronics reserves the right to change products or specification without notice.

Document Title

32M Bit (2M x16) Page Mode / Multi-Bank NOR Flash Memory

Revision History

<u>Revision No.</u>	<u>History</u>	<u>Draft Date</u>	<u>Remark</u>
0.0	Initial draft	October 11, 2006	Target Information
0.1	-Accelerated Program Time is changed from 4ns to 6ns. -Accelerated Quad Word Program Time is changed from 1.2ns to 1.5ns.	November 13, 2006	Target Information
0.2	- Die version is changed E-die to B-die (K8P3215UQE --> K8P3215UQB)	November 21, 2006	Target Information
0.3	-64FBGA 13x11 with 1.0mm Ball Pitch is added. -56FBGA is deleted. -48FBGA 6x8.5 is deleted. -56TSOP 20x14 is deleted. -CFI code is changed Data 00h is changed to 07h in address 35h Data 00h is changed to 20h in address 37h -Change Vih Min. from Vio-0.4(2.2) to Vio-0.4(Vccx0.8) -Change Vil Max. from 0.4(0.8) to 0.4(Vccx0.2)	January 15, 2007	Target Information
0.4	- Group block protect time : 100us --> 120us - Group block unprotect time : 1.2ms --> 3ms In Figure 8. Block Group Protection & Unprotection Algorithms & Block Group Protect & Unprotect Operations timing	February 08, 2007	Target Information
0.5	- Package Hight is changed from 1.3 ±0.10 to 1.2 ±0.10.	February 15, 2007	Target Information
0.6	- 48FBGA, 48TSOP dimension are added.	March 22, 2007	Preliminary
1.0	- Specification is finalized. - Package 'E' is added in ordering information.	April 19, 2007	
1.1	- "#OE or #CE should be toggled in each toggle bit status read." is added in DQ2 & DQ6 toggle bit.	April 23, 2007	

K8P3215UQB

FLASH MEMORY

32M Bit (2M x16) Page Mode / Multi-Bank NOR Flash Memory

FEATURES

- Single Voltage, 2.7V to 3.6V for Read and Write operations
Voltage range of 2.7V to 3.1V valid for MCP product
- Organization
2M x16 bit (Word mode Only)
- Fast Read Access Time : 55ns
- Page Mode Operation
8 Words Page access allows fast asynchronous read
Page Read Access Time : 20ns
- Read While Program/Erase Operation
- Multiple Bank architectures (4 banks)
Bank 0: 4Mbit (4Kw x 8 and 32Kw x 7)
Bank 1: 12Mbit (32Kw x 24)
Bank 2: 12Mbit (32Kw x 24)
Bank 3: 4Mbit (4Kw x 8 and 32Kw x 7)
- OTP Block : Extra 256 word
- 128word for factory and 128word for customer OTP
- Power Consumption (typical value)
- Active Read Current : 45mA (@10MHz)
- Program/Erase Current : 17mA
- Read While Program or Read While Erase Current : 35mA
- Standby Mode/Auto Sleep Mode : 15uA
- Support Single & Quad word accelerate program
- WP/ACC input pin
- Allows special protection of two outermost boot blocks at V_{IL} , regardless of block protect status
- Removes special protection of two outermost boot block at V_{IH} , the two blocks return to normal block protect status
- Accelerated Quadword Program time : 1.5us
- Erase Suspend/Resume
- Program Suspend/Resume
- Unlock Bypass Program
- Hardware RESET Pin
- Command Register Operation
- Block Protection / Unprotection
- Supports Common Flash Memory Interface
- Operation Temperature Range
- Industrial Temperature : -40°C to 85°C
- Extended Temperature : -25°C to 85°C
- Commercial Temperature : 0°C to 70°C

- Endurance : 100,000 Program/Erase Cycles Minimum
- Data Retention : 10 years
- Vio options at 1.8V and 3V I/O
- Package options
- 48 Pin TSOP (20x12mm)
- 48 Ball FBGA (6x8mm, 0.8mm Ball Pitch)
- 64 Ball FBGA (13x11mm, 1.0mm Ball Pitch)

GENERAL DESCRIPTION

The K8P3215UQB featuring single 3.0V power supply, is a 32Mbit NOR-type Flash Memory organized as 2Mx16. The memory architecture of the device is designed to divide its memory arrays into 78 blocks with independent hardware protection. This block architecture provides highly flexible erase and program capability. The K8P3215UQB NOR Flash consists of four banks. This device is capable of reading data from one bank while programming or erasing in the other banks.

The K8P3215UQB offers fast page access time of 20~30ns with random access time of 55~70ns. The device's fast access times allow high speed microprocessors to operate without wait states. The device performs a program operation in unit of 16 bits (Word) and erases in units of a block. Single or multiple blocks can be erased. The block erase operation is completed within typically 0.7 sec. The device requires 17mA as program/erase current in the commercial and industrial temperature ranges.

The K8P3215UQB NOR Flash Memory is created by using Samsung's advanced CMOS process technology. This device is available in 48 Pin TSOP package and 48/64 Ball FBGA package. The device is compatible with EPROM applications to require high-density and cost-effective non-volatile read/write storage solutions.

PIN DESCRIPTION

Pin Name	Pin Function
A0 - A20	Address Inputs
DQ0 - DQ15	Data Inputs / Outputs
\overline{CE}	Chip Enable
\overline{OE}	Output Enable
\overline{RESET}	Hardware Reset Pin
RY/ \overline{BY}	Ready/Busy Output
\overline{WE}	Write Enable
WP/ACC	Hardware Write Protection/Program Acceleration
Vcc	Power Supply
Vss	Ground
N.C	No Connection

SAMSUNG ELECTRONICS CO., LTD. reserves the right to change products and specifications without notice.



K8P3215UQB

FLASH MEMORY

PIN CONFIGURATION

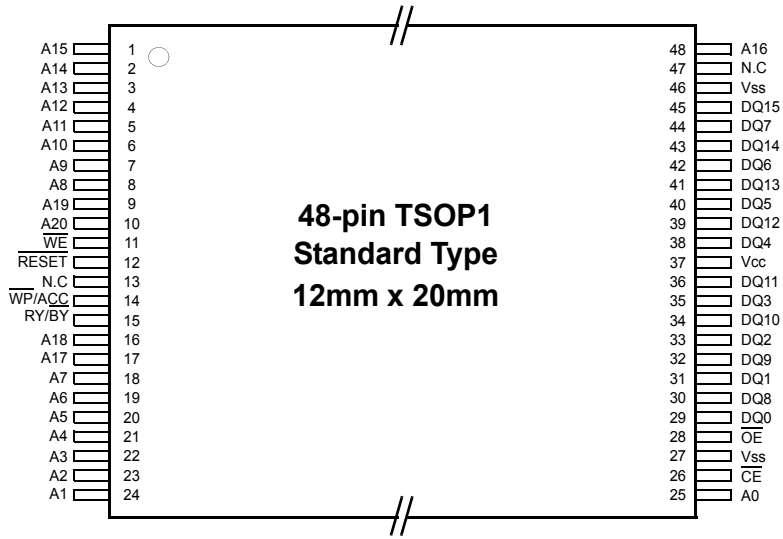

K8P3215UQB

FLASH MEMORY

64 Ball FBGA TOP VIEW (BALL DOWN)

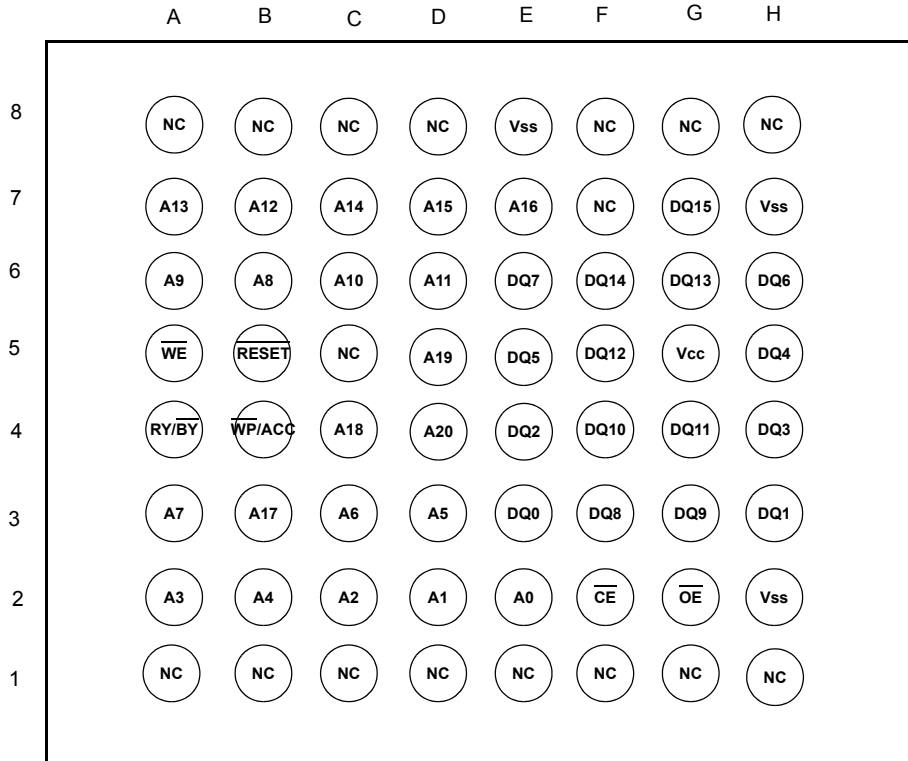

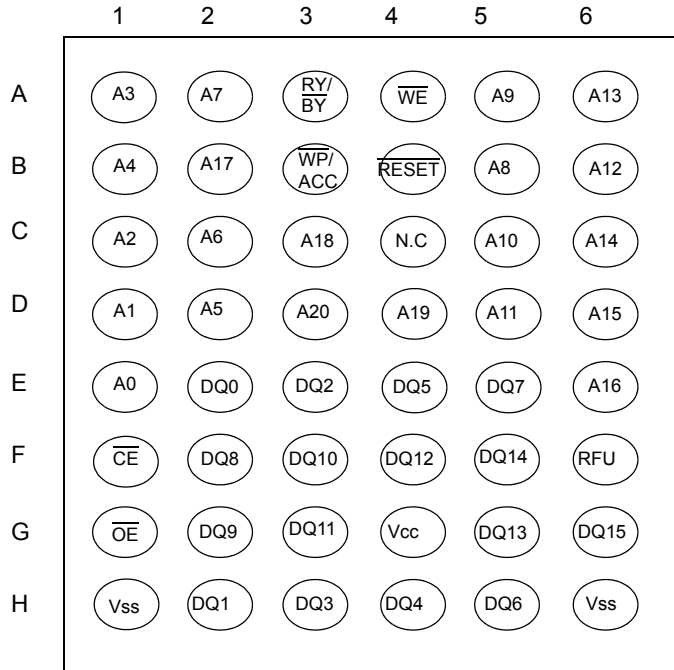

48 Ball FBGA TOP VIEW (BALL DOWN)

FUNCTIONAL BLOCK DIAGRAM

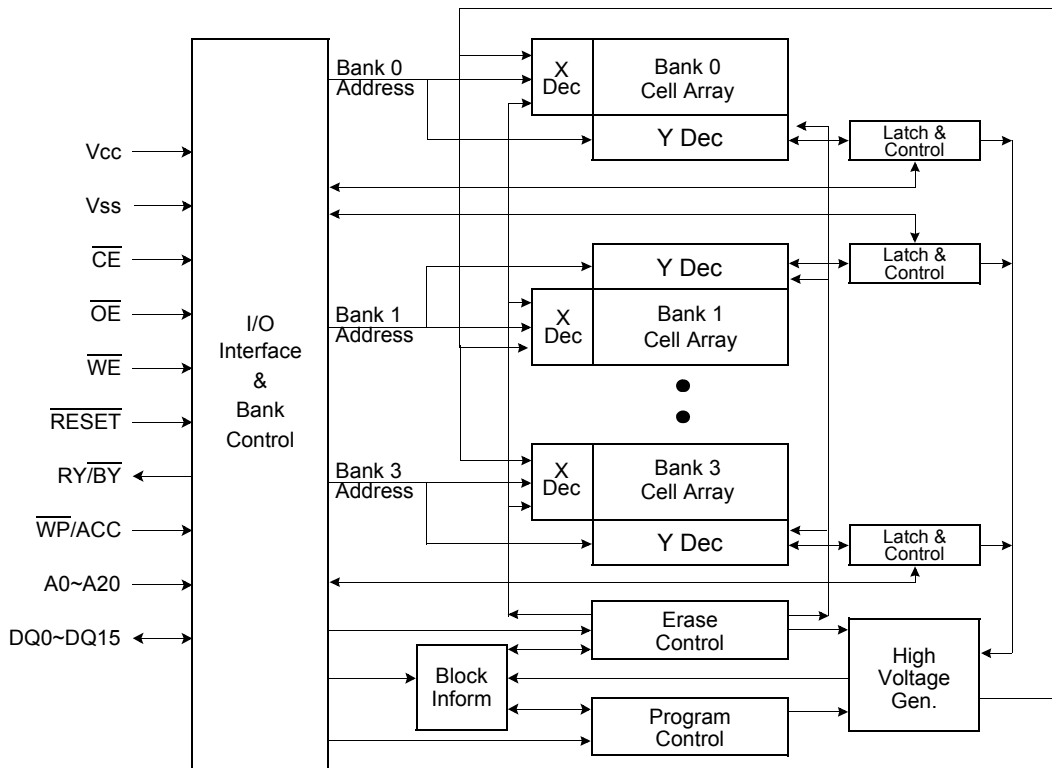

K8P3215UQB

FLASH MEMORY

ORDERING INFORMATION



Table 1. PRODUCT LINE-UP

Speed Item	Speed Option			
	4A	4B	4C	4D
Vcc	2.7V~3.6V			
VIO (1)	1.65~1.95V , 2.7~3.6V			
Max. Address Access Time (ns)	55ns	60ns	65ns	70ns
Max. \overline{CE} Access Time (ns)	55ns	60ns	65ns	70ns
Max. \overline{OE} Access Time (ns)	20ns	25ns	25ns	30ns
Max. Page Access Time (ns)	20ns	25ns	25ns	30ns

Notes :
1. Only 4C or 4D speed options can be provided in case of using 1.65~1.95V V_{IO}.

Table 2. K8P3215UQB DEVICE BANK DIVISIONS

Bank 0, Bank 3		Bank 1, Bank 2	
Mbit	Block Sizes	Mbit	Block Sizes
4 Mbit	4 Kw x 8 and 32 Kw x 7	12 Mbit	32 Kw x 24

Table 3. OTP BLOCK

OTP	Block Address A20~A8	Area	Block Size	Address Range
	0000h	Factory-Locked Area	128 words	000000h-00007Fh
		Customer-Locked Area	128 words	000080h-0000FFh

After entering OTP block, any issued addresses should be in the range of OTP block address

Table 4. K8P3215UQB DEVICE BANK DIVISIONS

Bank	Number of Blocks	Block Size
0	8	4 Kwords
	7	32 Kwords
1	24	32 Kwords
2	24	32 Kwords
3	7	32 Kwords
	8	4 Kwords

PRODUCT INTRODUCTION

The K8P3215UQB is an 32Mbit NOR-type Flash memory. The device features single voltage power supply operating within the range of 2.7V to 3.6V. The device is programmed by using the Channel Hot Electron (CHE) injection mechanism which is used to program EPROMs. The device is erased electrically by using Fowler-Nordheim tunneling mechanism. To provide highly flexible erase and program capability, the device adapts a block memory architecture that divides its memory array into 78 blocks (4 Kw x 16 , 32 Kw x 62). Programming is done in units of 16 bits (Word). All bits of data in one or multiple blocks can be erased simultaneously when the device executes the erase operation. To prevent the device from accidental erasing or over-writing the programmed data, 78 memory blocks can be hardware protected. The device offers fast page access time of 20~30ns with random access time of 55~70ns supporting high speed microprocessors to operate without any wait states.

The command set of K8P3215UQB is fully compatible with standard Flash devices. The device is controlled by chip enable (\overline{CE}), output enable (\overline{OE}) and write enable (\overline{WE}). Device operations are executed by selective command codes. The command codes to be combined with addresses and data are sequentially written to the command registers using microprocessor write timing. The command codes serve as inputs to an internal state machine which controls the program/erase circuitry. Register contents also internally latch addresses and data necessary to execute the program and erase operations. The K8P3215UQB is implemented with Internal Program/Erase Algorithms to execute the program/erase operations. The Internal Program/Erase Algorithms are invoked by program/erase command sequences. The Internal Program Algorithm automatically programs and verifies data at specified addresses. The Internal Erase Algorithm automatically pre-programs the memory cell which is not programmed and then executes the erase operation. The K8P3215UQB has means to indicate the status of completion of program/erase operations. The status can be indicated via the $\overline{RY/BY}$ pin, \overline{Data} polling of DQ7, or the Toggle bit (DQ6). Once the operations have been completed, the device automatically resets itself to the read mode.

Table 5. Operations Table

Operation	\overline{CE}	\overline{OE}	\overline{WE}	WP/ACC	A9	A6	A1	A0	DQ8/DQ15	DQ0/DQ7	\overline{RESET}
Read	L	L	H	L/H	A9	A6	A1	A0	DOUT	DOUT	H
Stand-by	H	X	X	(2)	X	X	X	X	High-Z	High-Z	(2)
Output Disable	L	H	H	L/H	X	X	X	X	High-Z	High-Z	H
Reset	X	X	X	L/H	X	X	X	X	High-Z	High-Z	L
Write	L	H	L	(4)	A9	A6	A1	A0	DIN	DIN	H
Enable Block Protect (3)	L	H	L	L/H	X	L	H	L	X	DIN	V _{ID}
Enable Block Unprotect (3)	L	H	L	(4)	X	H	H	L	X	DIN	V _{ID}
Temporary Block Unprotect	X	X	X	(4)	X	X	X	X	X	X	V _{ID}
Auto Select Manufacturer ID (5)	L	L	H	L/H	V _{ID}	L	L	L	X	Code(See Table 7)	H
Auto Select Device Code (5)	L	L	H	L/H	V _{ID}	L	L	H	X	Code(See Table 7)	H

Notes :

1. L = V_{IL} (Low), H = V_{IH} (High), V_{ID} = 8.5V to 9.5V, D_{IN} = Data in, D_{OUT} = Data out, X = Don't care.
2. $\overline{WP/ACC}$ and \overline{RESET} pin are asserted at V_{cc}±0.2 V or V_{ss}±0.2 V in the Stand-by mode.
3. Addresses must be composed of the Block address (A12 - A20).
The Block Protect and Unprotect operations may be implemented via programming equipment too. Refer to the "Block Protection and Unprotection".
4. If $\overline{WP/ACC}$ =V_{IL}, the two outermost boot blocks is protected. If $\overline{WP/ACC}$ =V_{IH}, the two outermost boot block protection depends on whether those blocks were last protected or unprotected using the method described in "Block Protection and Unprotection". If $\overline{WP/ACC}$ =V_{IH}, all blocks will be temporarily unprotected.
5. Manufacturer and device codes may also be accessed via a command register write sequence. Refer to Table 7.

K8P3215UQB

FLASH MEMORY

COMMAND DEFINITIONS

The K8P3215UQB operates by selecting and executing its operational modes. Each operational mode has its own command set. In order to select a certain mode, a proper command with specific address and data sequences must be written into the command register. Writing incorrect information which include address and data or writing an improper command will reset the device to the read mode. The defined valid register command sequences are stated in Table 6. Note that Erase Suspend (B0H) and Erase Resume (30H) commands are valid only while the Block Erase Operation is in progress. Program Suspend (B0H) and Program Resume (30H) commands are valid during Program Operation and Erase Suspend - Program Operation. Only Read Operation is available after Program Suspend Operation.

Table 6. Command Sequences

Command Sequence		Cycle	1st Cycle	2nd Cycle	3rd Cycle	4th Cycle	5th Cycle	6th Cycle
Read	Addr	1	RA					
	Data		RD					
Reset	Addr	1	XXXH					
	Data		F0H					
Autoselect Manufacturer ID (1,2)	Add	4	555H	2AAH	DA/555H	DA/X00H		
	Data		AAH	55H	90H	ECH		
Autoselect Device Code (1,2,3)	Addr	4	555H	2AAH	DA/555H	DA/X01H	DA/X0EH	DA/X0FH
	Data		AAH	55H	90H	257EH	2503H	2501H
Autoselect BlockProtectVerify (1,2)	Addr	4	555H	2AAH	DA/555H	BA / X02H		
	Data		AAH	55H	90H	(See Table 7)		
Autoselect OTP Factory Protect	Addr	4	555H	2AAH	DA/555H	X03H		
	Data		AAH	55H	90H	(See Note 10)		
Program	Addr	4	555H	2AAH	555H	PA		
	Data		AAH	55H	A0H	PD		
Unlock Bypass	Addr	3	555H	2AAH	555H			
	Data		AAH	55H	20H			
Unlock Bypass Program	Addr	2	XXXH	PA				
	Data		A0H	PD				
Unlock Bypass Block Erase	Addr	2	XXXH	BA				
	Data		80H	30H				
Unlock Bypass Chip Erase	Addr	2	XXXH	XXXH				
	Data		80H	10H				
Unlock Bypass Reset	Addr	2	XXXH	XXXH				
	Data		90H	00H				
Unlock Bypass CFI	Addr	1	XXH					
	Data		98H					
Chip Erase	Addr	6	555H	2AAH	555H	555H	2AAH	555H
	Data		AAH	55H	80H	AAH	55H	10H
Block Erase	Addr	6	555H	2AAH	555H	555H	2AAH	BA
	Data		AAH	55H	80H	AAH	55H	30H
Block Erase Suspend (4, 5)	Addr	1	DA					
	Data		B0H					
Block Erase Resume	Addr	1	DA					
	Data		30H					
Program Suspend (6,7)	Addr	1	DA					
	Data		B0H					
Program Resume	Addr	1	DA					
	Data		30H					
CFI Query (8)	Addr	1	55H					
	Data		98H					

K8P3215UQB

FLASH MEMORY

Table 6. Command Sequences (Continued)

Command Definitions		Cycle	1st Cycle	2nd Cycle	3rd Cycle	4th Cycle	5th Cycle	6th Cycle
Accelerated Program	Addr	2	XXH	PA				
	Data		A0H	PD				
Quadruple word Accelerated Program(9)	Addr	5	XXXH	PA1	PA2	PA3	PA4	
	Data		A5H	PD1	PD2	PD3	PD4	
Enter OTP Block Region	Addr	3	555H	2AAH	555H			
	Data		AAH	55H	88H			
Exit OTP Block Region	Addr	4	555H	2AAH	555H	XXX		
	Data		AAH	55H	90H	00H		
OTP Protection bit Program (11,12)	Addr	6	555H	2AAH	555H	OW	OW	OW
	Data		AAH	55H	60H	68H	48H	RD(0)
OTP Protection bit Status	Addr	5	555H	2AAH	555H	OW	OW	
	Data		AAH	55H	60H	48H	RD(0)	

- Notes :**
- RA : Read Address, PA : Program Address, RD : Read Data, PD : Program Data
 - DA : Bank Address (A19- A20), BA : Block Address (A12 - A20), ABP : Address of the block to be protected or unprotected, X = Don't care .
 - OW = Address (A7:A0) is (00011010), RD(0) = Read Data DQ0 for protection indicator bit ,RD(1) = Read Data DQ1 for PPB Lock status.
 - DQ8 - DQ15 are don't care in command sequence, except for RD and PD.
 - A11 - A20 are also don't care, except for the case of special notice.
1. To terminate the Autoselect Mode, it is necessary to write Reset command to the register.
 2. The 4th cycle data of Autoselect mode is output data.
The 3rd and 4th cycle bank addresses of Autoselect mode must be same.
 3. Device ID must be read across cycles 4, 5 and 6.
K8P2815U(xOEh = 2508h, x0Fh = 2501h), K8P6415U(xOEh = 2506h, x0Fh = 2501h), K8P3215U(xOEh = 2503h, x0Fh = 2501h)
 4. The Read / Program operations at non-erasing blocks and the autoselect mode are allowed in the Erase Suspend mode.
 5. The Erase Suspend command is applicable only to the Block Erase operation.
 6. The Read Operation is allowed in the Program Suspend mode.
 7. The Program Suspend command is applicable to Program and Erase Suspend - Program operation.
 8. Command is valid when the device is in read mode or Autoselect mode.
 9. Quadruple word accelerated program is invoked only at Vpp=Vid, Vpp setup is required prior to this command sequence.
PA1,PA2,PA3,PA4 have the same A20~A2 address
 10. The data is DQ6=1 for customer locked and DQ7=1 for factory locked.
 11. Reset command returns device to reading array.
 12. Cycle 4 programs the addressed locking bit. Cycle 5 and 6 validate bit has been fully programmed when DQ0=1. If DQ0=0 in cycle 6, program command must be issued and verified again.

Table 7. K8P3215UQB Autoselect Codes, (High Voltage Method)

Description		\overline{CE}	\overline{OE}	\overline{WE}	A20 to A12	A10	A9	A8	A7	A6	A5 to A4	A3	A2	A1	A0	DQ15 to DQ8	DQ7 to DQ0
Manufacturer ID		L	L	H	DA	X	V _{id}	X	L	L	X	L	L	L	L	X	ECH
Device ID	Read Cycle 1											L	L	L	H	25H	7EH
	Read Cycle 2	L	L	H	DA	X	V _{id}	X	L	L	L	H	H	H	L	25H	03H
	Read Cycle 3											H	H	H	H	25H	01H
Block Protection Verification		L	L	H	BA	X	V _{id}	X	L	L	L	L	L	H	L	X	01H(Protected) 00H (Unprotected)
OTP Indicator Bit (DQ7, DQ6)		L	L	H	DA	X	V _{id}	X	X	L	L	L	L	H	H	X	DQ7=1(Factory locked) DQ6=1(Customer locked)
Master locking bit Indicator Bit		L	L	H	BA	X	V _{id}	X	L	L	L	L	H	H	H	X	01H(Protected) 00H (Unprotected)

- Notes :** 1. L=Logic Low=V_{IL}, H=Logic High=V_{IH}, DA= Bank Address, BA=Block Address, X=Don't care.

DEVICE OPERATION

Read Mode

The K8P3215UQB is controlled by Chip Enable (CE), Output Enable (OE) and Write Enable (WE). When CE and OE are low and WE is high, the data stored at the specified address location, will be the output of the device. The outputs are in high impedance state whenever CE or OE is high. The K8P3215UQB is available for Page mode. Page mode provides fast access time for high performance system.

Standby Mode

The K8P3215UQB features Stand-by Mode to reduce power consumption. This mode puts the device on hold when the device is deselected by making CE high (CE = VIH). Refer to the DC characteristics for more details on stand-by modes.

Output Disable

The device outputs are disabled when OE is High (OE = VIH). The output pins are in high impedance state.

Automatic Sleep Mode

The K8P3215UQB features Automatic Sleep Mode to minimize the device power consumption. When addresses remain steady for tAA+30ns, the device automatically activates the Automatic Sleep Mode. In the sleep mode, output data is latched and always available to the system. When addresses are changed, the device provides new data without wait time.

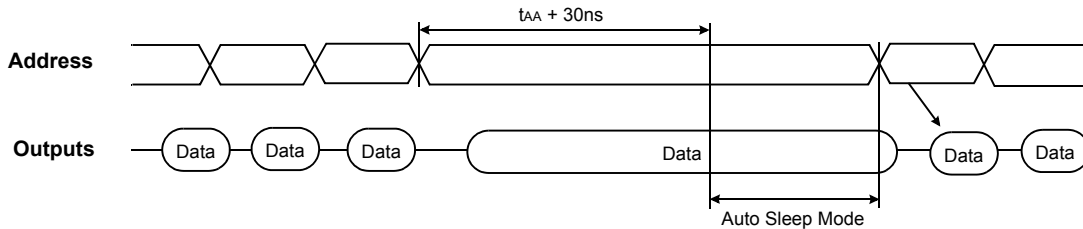
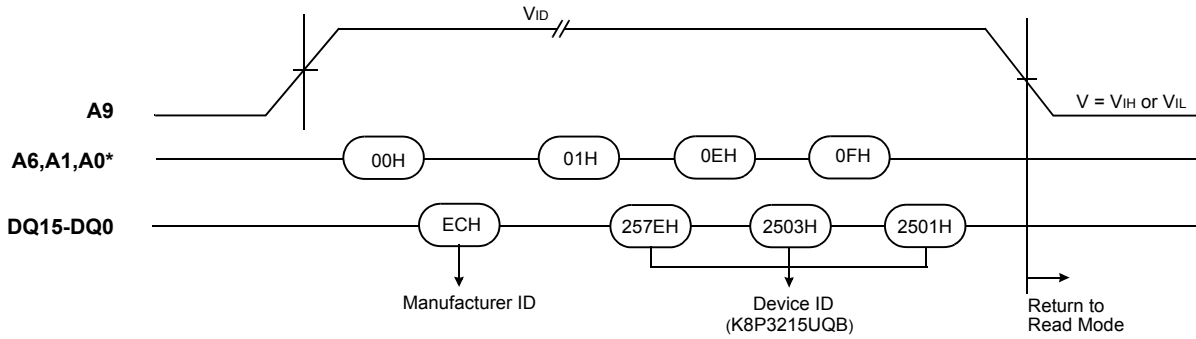

Figure 1. Auto Sleep Mode Operation

Autoselect Mode

The K8P3215UQB offers the Autoselect Mode to identify manufacturer, device type and block protection verification by reading a binary code. The Autoselect Mode allows programming equipment to automatically match the device to be programmed with its corresponding programming algorithm. In addition, this mode allows the verification of the status of write protected blocks. This mode is used by two method. The one is high voltage method to be required VID (8.5V - 9.5V) on address pin A9. When A9 is held at VID and the bank address or block address is asserted, the device outputs the valid data via DQ pins(see Table 7 and Figure 2). The rest of addresses except A0, A1 and A6 are don't care. The other is autoselect command method that the autoselect code is accessible by the commamd sequence without VID. The manufacturer, device code and block protection verification can be read via the command register. The Command Sequence is shown in Table 7 and Figure 3. The autoselect operation of block protection verification is initiated by first writing two unlock cycle. The third cycle must contain the bank address and autoselect command (90H). If Block address while (A6, A1, A0) = (0,1,0) is finally asserted on the address pin, it will produce a logical "1" at the device output DQ0 to indicate a write protected block or a logical "0" at the device output DQ0 to indicate a write unprotected block. To terminate the autoselect operation, write Reset command (F0H) into the command register.



Note : The addresses other than A0 , A1 and A6 are Don't care. Please refer to Table 7 for device code.

Figure 2. Autoselect Operation (by High Voltage Method)

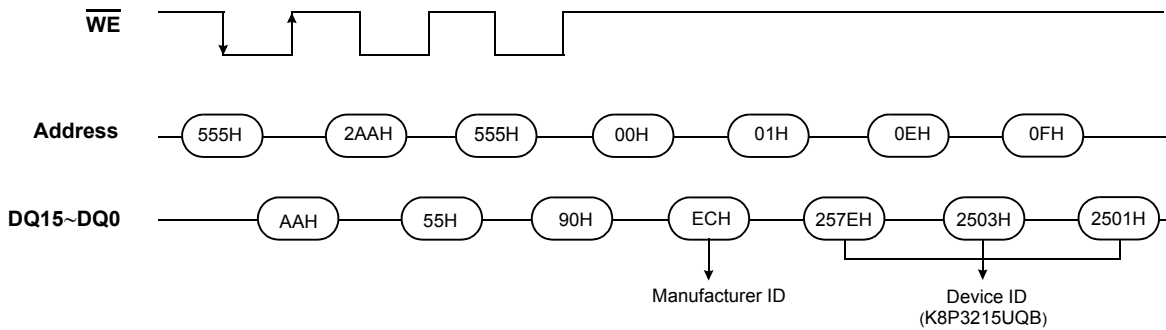

Note : The 3rd Cycle and 4th Cycle address must include the same bank address. Please refer to Table 7 for device code.

Figure 3. Autoselect Operation (by Command Sequence Method)

Write (Program/Erase) Mode

The K8P3215UQB executes its program/erase operations by writing commands into the command register. In order to write the commands to the register, \overline{CE} and \overline{WE} must be low and \overline{OE} must be high. Addresses are latched on the falling edge of \overline{CE} or \overline{WE} (whichever occurs last) and the data are latched on the rising edge of \overline{CE} or \overline{WE} (whichever occurs first). The device uses standard microprocessor write timing.

Program

The K8P3215UQB can be programmed in units of a word. Programming is writing 0's into the memory array by executing the Internal Program Routine. In order to perform the Internal Program Routine, a four-cycle command sequence is necessary. The first two cycles are unlock cycles. The third cycle is assigned for the program setup command. In the last cycle, the address of the memory location and the data to be programmed at that location are written. The device automatically generates adequate program pulses and verifies the programmed cell margin by the Internal Program Routine. During the execution of the Routine, the system is not required to provide further controls or timings.

During the Internal Program Routine, commands written to the device will be ignored. Note that a hardware reset during a program operation will cause data corruption at the corresponding location.

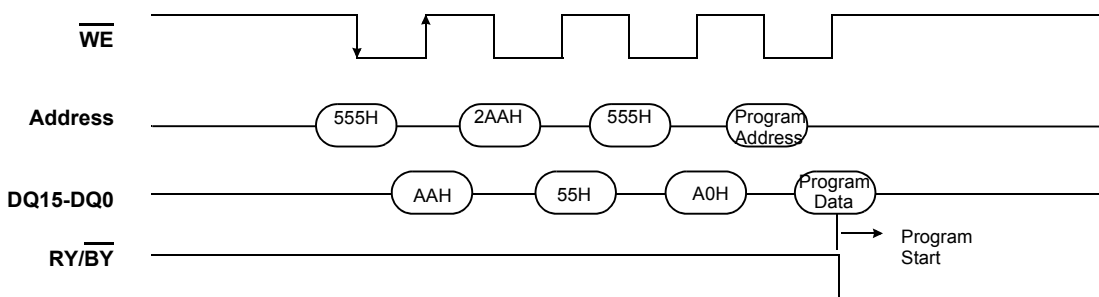

Figure 4. Program Command Sequence

K8P3215UQB

FLASH MEMORY

In across block boundaries and any sequence programming is allowed. A bit cannot be programmed from '0' back to '1'. If attempting to do, it may cause that bank to set DQ5 = 1, or cause the DQ7 and DQ6 status bits to indicate the operation was successful. However, a succeeding read will show that the data is still '0'. Only erase operations can convert a '0' to a '1'.

Unlock Bypass

The K8P3215UQB provides the unlock bypass mode to save its operation time. This mode is possible for program, block erase and chip erase operation. There are two methods to enter the unlock bypass mode. The mode is invoked by the unlock bypass command sequence. Unlike the standard program/erase command sequence that contains four to six bus cycles, the unlock bypass program/erase command sequence comprises only two bus cycles. The unlock bypass mode is engaged by issuing the unlock bypass command sequence which is comprised of three bus cycles. Writing first two unlock cycles is followed by a third cycle containing the unlock bypass command (20H). Once the device is in the unlock bypass mode, the unlock bypass program/erase command sequence is necessary. The unlock bypass program command sequence is comprised of only two bus cycles; writing the unlock bypass program command (A0H) is followed by the program address and data. This command sequence is the only valid one for programming the device in the unlock bypass mode. Also, The unlock bypass erase command sequence is comprised of two bus cycles; writing the unlock bypass block erase command(80H-30H) or writing the unlock bypass chip erase command(80H-10H). This command sequences are the only valid ones for erasing the device in the unlock bypass mode. The unlock bypass reset command sequence is the only valid command sequence to exit the unlock bypass mode. The unlock bypass reset command sequence consists of two bus cycles. The first cycle must contain the data (90H). The second cycle contains only the data (00H). Then, the device returns to the read mode.

Chip Erase

To erase a chip is to write 1's into the entire memory array by executing the Internal Erase Routine. The Chip Erase requires six bus cycles to write the command sequence. The erase set-up command is written after first two "unlock" cycles. Then, there are two more write cycles prior to writing the chip erase command. The Internal Erase Routine automatically pre-programs and verifies the entire memory for an all zero data pattern prior to erasing. The automatic erase begins on the rising edge of the last WE or CE pulse in the command sequence and terminates when DQ7 is "1". After that the device returns to the read mode.

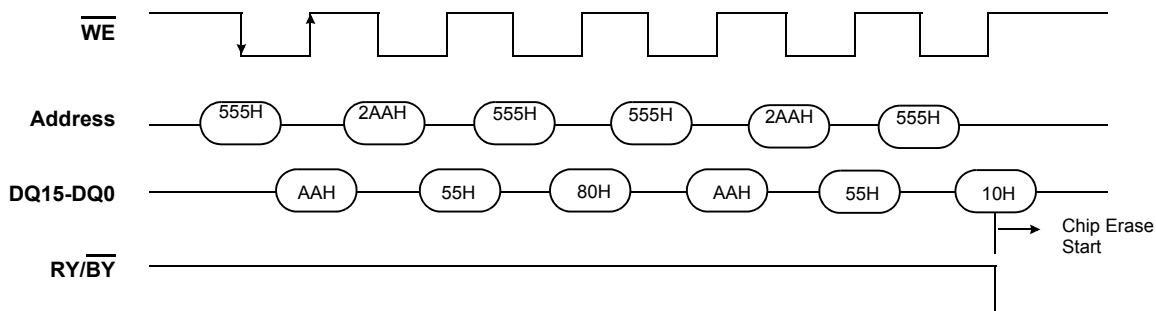

Figure 5. Chip Erase Command Sequence

Block Erase

To erase a block is to write 1's into the desired memory block by executing the Internal Erase Routine. The Block Erase requires six bus cycles to write the command sequence shown in Table 6. After the first two "unlock" cycles, the erase setup command (80H) is written at the third cycle. Then there are two more "unlock" cycles followed by the Block Erase command. The Internal Erase Routine automatically pre-programs and verifies the entire memory prior to erasing it. The block address is latched on the falling edge of WE or CE, while the Block Erase command is latched on the rising edge of WE or CE.

Multiple blocks can be erased sequentially by writing the six bus-cycle operation in Figure 6. Upon completion of the last cycle for the Block Erase, additional block address and the Block Erase command (30H) can be written to perform the Multi-Block Erase. An 50us (typical) "time window" is required between the Block Erase command writes. The Block Erase command must be written within the 50us "time window", otherwise the Block Erase command will be ignored. The 50us "time window" is reset when the falling edge of the WE occurs within the 50us of "time window" to latch the Block Erase command. During the 50us of "time window", any command other than the Block Erase or the Erase Suspend command written to the device will reset the device to read mode. After the 50 us of "time window", the Block Erase command will initiate the Internal Erase Routine to erase the selected blocks. Any Block Erase address and command following the exceeded "time window" may or may not be accepted. No other commands will be recognized except the Erase Suspend command.

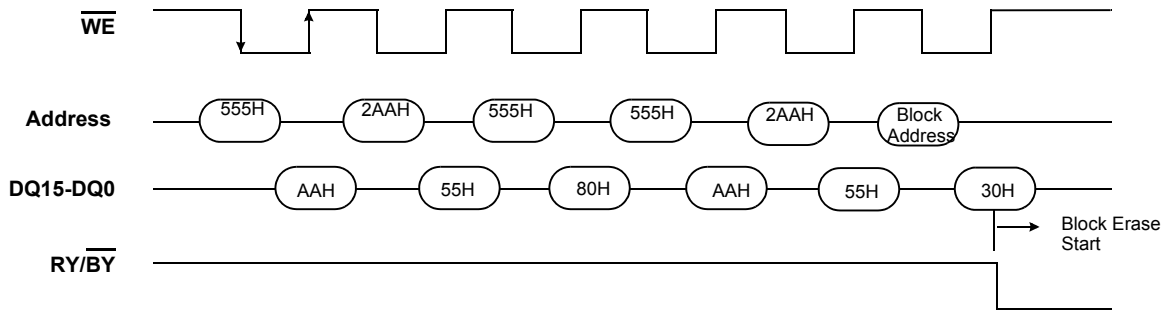

Figure 6. Block Erase Command Sequence

Erase Suspend / Resume

The Erase Suspend command interrupts the Block Erase to read or program data in a block that is not being erased. The Erase Suspend command is only valid during the Block Erase operation including the time window of 50us. The Erase Suspend command is not valid while the Chip Erase or the Internal Program Routine sequence is running. When the Erase Suspend command is written during a Block Erase operation, the device requires a maximum of 20us to suspend the erase operation. But, when the Erase Suspend command is written during the block erase time window (50us), the device immediately terminates the block erase time window and suspends the erase operation. After the erase operation has been suspended, the device is available for reading or programming data in a block that is not being erased. The system may also write the autoselect command sequence when the device is in the Erase Suspend mode. When the Erase Resume command is executed, the Block Erase operation will resume. When the Erase Suspend or Erase Resume command is executed, the addresses are in Don't Care state.

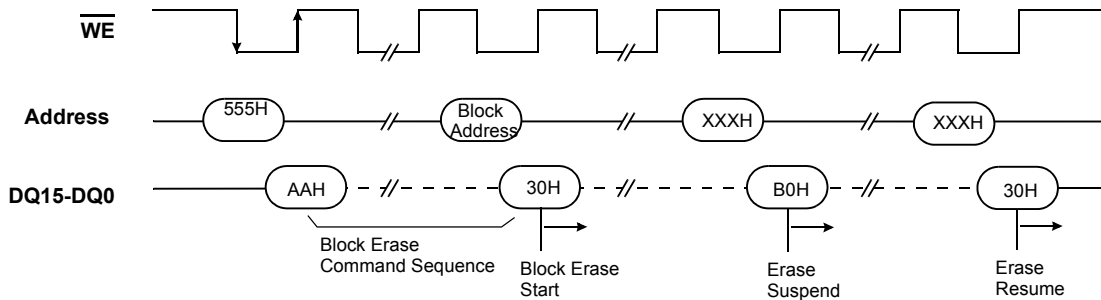

Figure 7. Erase Suspend/Resume Command Sequence

Program Suspend / Resume

The Program Suspend command interrupts the Program operation. Also the Program Suspend command interrupts the Program operation during Erase Suspend Mode. The Read operation is available only during Program Suspend. When the Program Suspend command is written during a Program operation, the device requires a maximum of 10us to suspend the Program operation. The system may also write the autoselect command sequence when the device is in the Program Suspend mode. When the Program Resume command is executed, the Program operation will resume. When the Program Suspend or Program Resume command is executed, the addresses are in Don't Care state.

Read While Write

The K8P3215UQB provides multi-bank memory architecture that divides the memory array into four banks. The device is capable of reading data from one bank and writing data to the other bank simultaneously. This is so called the Read While Write operation with multi-bank architecture; this feature provides the capability of executing the read operation during Program/Erase or Erase-Suspend-Program operation. The Read While Write operation is prohibited during the chip erase operation. It is also allowed during erase operation when either single block or multiple blocks from same bank are loaded to be erased. It means that the Read While Write operation is prohibited when blocks from one Bank and another blocks from the other Bank are loaded all together for the multi-block erase operation.

Write Protect (\overline{WP})

The $\overline{WP/ACC}$ pin has two useful functions. The one is that certain boot block is protected by the hardware method not to use V_{IL} . The other is that program operation is accelerated to reduce the program time (Refer to Accelerated program Operation Paragraph). When the $\overline{WP/ACC}$ pin is asserted at V_{IL} , the device can not perform program and erase operation in the two "outermost" 4Kword boot blocks on both ends of the flash array independently of whether those blocks were protected or unprotected using the method described in "Block protection/Unprotection". (BA77 and BA76, BA0 and BA1)

The write protected blocks can only be read. This is useful method to preserve an important program data.

When the $\overline{WP/ACC}$ pin is asserted at V_{IH} , the device reverts to whether the two outermost 4Kword boot blocks were last set to be protected or unprotected. That is, block protection or unprotection for these two blocks depends on whether they were last protected or unprotected using the method described in "Block protection/unprotection".

Recommend that the $\overline{WP/ACC}$ pin must not be in the state of floating or unconnected, otherwise the device may be led to malfunction.

Software Reset

The reset command provides that the bank is reseted to read mode or erase-suspend-read mode. The addresses are in Don't Care state. The reset command is valid between the sequence cycles in an erase command sequence before erasing begins, or in a program command sequence before programming begins. This resets the bank in which was operating to read mode. if the device is erasing or programming, the reset command is invalid until the operation is completed. Also, the reset command is valid between the sequence cycles in an autoselect command sequence. In the autoselect mode, the reset command returns the bank to read mode. If a bank entered the autoselect mode in the Erase Suspend mode, the reset command returns the bank to erase-suspend-read mode. If DQ5 is high on erase or program operation, the reset command return the bank to read mode or erase-suspend-read mode if the bank was in the Erase Suspend state.

Hardware Reset

The K8P3215UQB offers a reset feature by driving the \overline{RESET} pin to V_{IL} . The \overline{RESET} pin must be kept low (V_{IL}) for at least 500ns. When the \overline{RESET} pin is driven low, any operation in progress will be terminated and the internal state machine will be reset to the standby mode after 20us. If a hardware reset occurs during a program operation, the data at that particular location will be lost. Once the \overline{RESET} pin is taken high, the device requires 200ns of wake-up time until outputs are valid for read access. Also, note that all the data output pins are tri-stated for the duration of the \overline{RESET} pulse.

The \overline{RESET} pin may be tied to the system reset pin. If a system reset occurs during the Internal Program and Erase Routine, the device will be automatically reset to the read mode ; this will enable the systems microprocessor to read the boot-up firmware from the Flash memory.

Power-up Protection

To avoid initiation of a write cycle during Vcc Power-up, $\overline{\text{RESET}}$ low must be asserted during power-up. After $\overline{\text{RESET}}$ goes high, the device is reset to the read mode.

Low Vcc Write Inhibit

To avoid initiation of a write cycle during Vcc power-up and power-down, a write cycle is locked out for Vcc less than 2.3V. If Vcc < VLKO (Lock-Out Voltage), the command register and all internal program/erase circuits are disabled. Under this condition the device will reset itself to the read mode. Subsequent writes will be ignored until the Vcc level is greater than VLKO. It is the user's responsibility to ensure that the control pins are logically correct to prevent unintentional writes when Vcc is above 2.3V.

Write Pulse Glitch Protection

Noise pulses of less than 5ns(typical) on $\overline{\text{CE}}$, $\overline{\text{OE}}$, or $\overline{\text{WE}}$ will not initiate a write cycle.

Logical Inhibit

Writing is inhibited under any one of the following conditions : $\overline{\text{OE}} = \text{VIL}$, $\overline{\text{CE}} = \text{VIH}$ or $\overline{\text{WE}} = \text{VIH}$. To initiate a write, $\overline{\text{CE}}$ and $\overline{\text{WE}}$ must be "0", while $\overline{\text{OE}}$ is "1".

Common Flash Memory Interface

Common Flash Memory Interface is contrived to increase the compatibility of host system software. It provides the specific information of the device, such as memory size, word configuration, and electrical features. Once this information has been obtained, the system software will know which command sets to use to enable flash writes, block erases, and control the flash component. When the system writes the CFI command(98H) to address 55H in word mode, the device enters the CFI mode. And then if the system writes the address shown in Table 8, the system can read the CFI data. Query data are always presented on the lowest-order data outputs(DQ0-7) only. In word(x16) mode, the upper data outputs(DQ8-15) is 00h. To terminate this operation, the system must write the reset command.

OTP Block Region

The OTP Block feature provides a 256-word Flash memory region that enables permanent part identification through an Electronic Serial Number (ESN). The OTP Block is customer lockable and shipped with itself unlocked, allowing customers to utilize the that block in any manner they choose. Indicator bits DQ6 and DQ7 are used to indicate the factory-locked and customer locked status of the part. The data is DQ6 = "1" for customer locked and DQ7 = "1" for factory locked.

The system accesses the OTP Block through a command sequence (see "Enter OTP Block / Exit OTP Block Command sequence" at Table 6). After the system has written the "Enter OTP Block" Command sequence, it may read the OTP Block by using the addresses (000000h~0000FFh) normally and may check the Protection Verify Bit (DQ7,DQ6) by using the "Autoselect Block Protection Verify" Command sequence with OTP Block address. This mode of operation continues until the system issues the "Exit OTP Block" Command sequence, a hardware reset or until power is removed from the device. On power-up, or following a hardware reset, the device reverts to sending commands to main blocks. Note that the Accelerated function and unlock bypass modes are not available when the OTP Block is enabled.

Customer Lockable

In a Customer lockable device, The OTP Block is one-time programmable and can be locked only once. Note that the Accelerated programming and Unlock bypass functions are not available when programming the OTP Block. Locking operation to the OTP Block is started by writing the "Enter OTP Block" Command sequence, and it can be permanently locked to "1" by issuing the OTP Protection bit program Command sequence. Once the OTP block is locked and verified, the system must write the Exit OTP block command to return to reading and writing the remainder of the array.

OTP Protection Bits

OTP protection bits prevent programming of the OTP block memory area. Once set, the OTP area are non-modifiable.

- The OTP Block Lock operation must be used with caution since, once locked, there is no procedure available for unlocking and none of the bits in the OTP Block space can be modified in any way.
- Suspend and resume operation are not supported during OTP protect, nor is OTP protect supported during any suspend operation.

High Voltage Block Protection

Block protection and unprotection may also be implemented using programming equipment. The procedure requires high voltage (V_{id}) to be placed on the RESET# pin. Refer to Figure 8 for details on this procedure. Note that for block unprotect, all unprotected blocks must first be protected prior to the first sector write cycle.

Accelerated Program Operation

Accelerated program operation is one of two functions provided by the \overline{WP}/ACC pin. When the \overline{WP}/ACC pin is asserted as V_{HH}, the device automatically enters the Unlock Bypass mode, temporarily unprotecting any protected blocks. The system would use a two-cycle program command sequence as required by the Unlock Bypass mode. Removing V_{HH} from the \overline{WP}/ACC pin returns the device to normal operation.

Recommend that the \overline{WP}/ACC pin must not be asserted at V_{HH} except on accelerated program operation, or the device may be damaged. In addition, the \overline{WP}/ACC pin must not be in the state of floating or unconnected, otherwise the device may be led to malfunction.

Single word accelerated program operation

The system would use two-cycle program sequence (One-cycle (XXX - A0H) is for single word program command, and Next one-cycle (PA - PD) is for program address and data).

Quadruple word accelerated program operation

As well as Single word accelerated program, the system would use five-cycle program sequence (One-cycle (XXX - A5H) is for quadruple word program command, and four cycles are for program address and data).

- Only four words programming is possible
- Each program address must have the same A20~A2 address
- The device automatically generates adequate program pulses and ignores other command after program command
- Program/Erase cycling must be limited below 100cycles for optimum performance.
- Read while Write mode is not guaranteed

Requirements : Ambient temperature : T_A=30°C±10°C

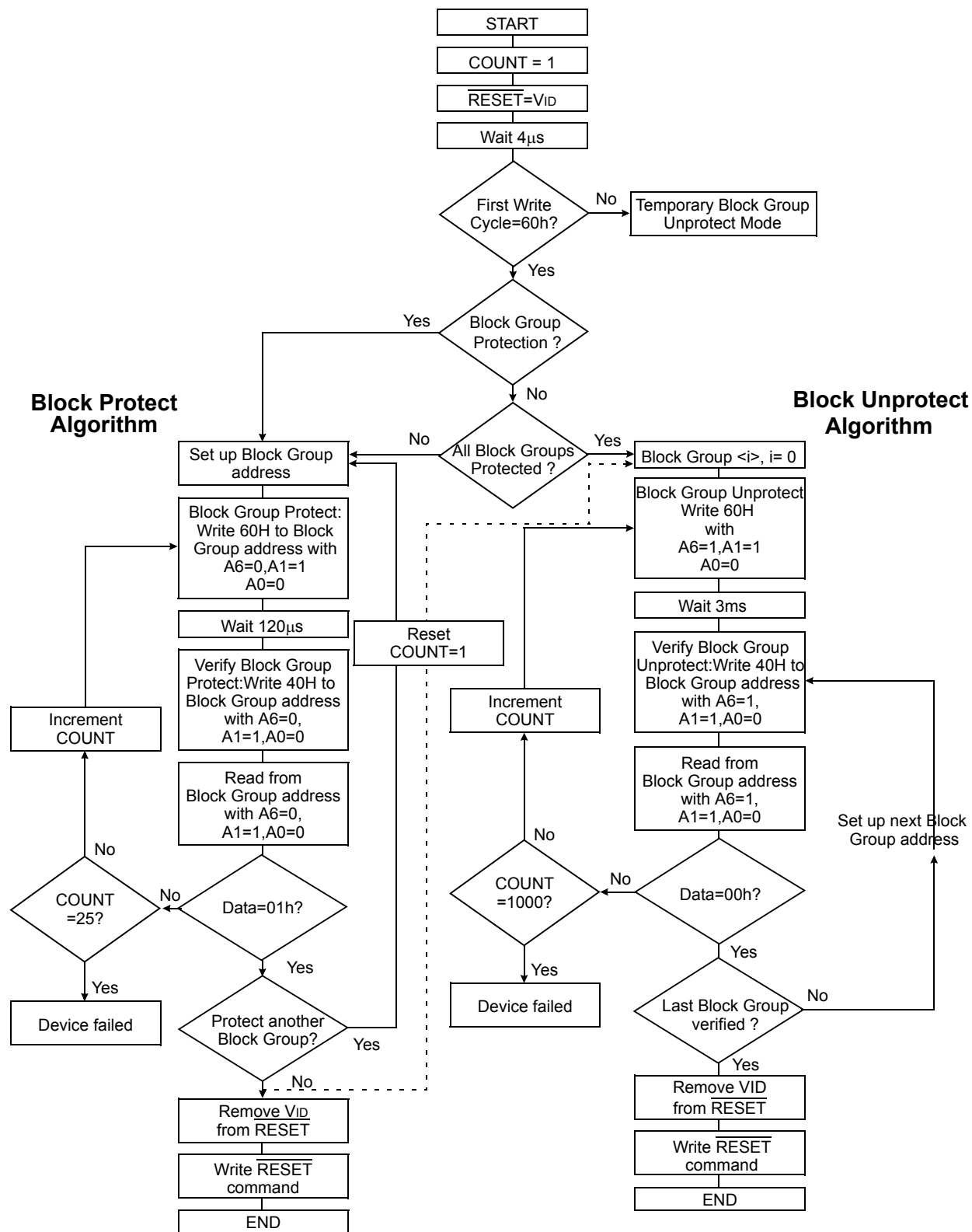

Note : All blocks must be protected before unprotect operation is executing.

Figure 8. Block Group Protection & Unprotection Algorithms

Table 8. Block Protection Schemes

DYB	PPB	PPB Lock	Block State
0	0	0	Unprotected-PPB and DYB are changeable
0	0	1	Unprotected-PPB not changeable and DYB are changeable
0	1	0	Protected-PPB and DYB are changeable
1	0	0	
1	1	0	
0	1	1	Protected-PPB not changeable, DYB is changeable
1	0	1	
1	1	1	

Block Protection

The K8P3215UQB features several levels of block protection, which can disable both the program and erase operations in certain blocks or block groups:

Persistent Block Protection

A command block protection method that replaces the old 12 V controlled protection method.

Password Block Protection

A highly sophisticated protection method that requires a password before changes to certain blocks or block groups are permitted

Selecting a Block Protection Mode

All parts default to operate in the Persistent Block Protection mode. The customer must then choose if the Persistent or Password Protection method is most desirable. There are two one-time programmable non-volatile bits that define which block protection-method will be used. If the Persistent Block Protection method is desired, programming the Persistent Block Protection Mode Locking Bit permanently sets the device to the Persistent Block Protection mode. If the Password Block Protection method is desired, programming the Password Mode Locking Bit permanently sets the device to the Password Block Protection mode.

It is not possible to switch between the two protection modes once a locking bit has been set. One of the two modes must be selected when the device is first programmed. This prevents a program or virus from later setting the Password Mode Locking Bit, which would cause an unexpected shift from the default Persistent Block Protection Mode into the Password Protection Mode.

The device is shipped with all blocks unprotected. Optional Samsung programming services enable programming and protecting blocks at the factory prior to shipping the device. Contact your local sales office for details.

It is possible to determine whether a block is protected or unprotected. See Autoselect Mode for details.

Persistent Block Protection

The Persistent Block Protection method replaces the 12 V controlled protection method in previous flash devices. This new method provides three different block protection states:

- Persistently Locked - The block is protected and cannot be changed.
- Dynamically Locked - The block is protected and can be changed by a simple command.
- Unlocked - The block is unprotected and can be changed by a simple command.

To achieve these states, three types of "bits" are used:

- Persistent Protection Bit
- Persistent Protection Bit Lock
- Persistent Block Protection Mode Locking Bit

Persistent Protection Bit (PPB)

A single Persistent (non-volatile) Protection Bit is assigned to a maximum four blocks (see the block address tables for specific block protection groupings). All 4 Kword boot-block sectors have individual block Persistent Protection Bits(PPBs) for greater flexibility. Each PPB is individually modifiable through the PPB Write Command.

The device erases all PPBs in parallel. If any PPB requires erasure, the device must be instructed to preprogram all of the block PPBs prior to PPB erasure. Otherwise, a previously erased block PPBs can potentially be over-erased. The flash device does not have a built-in means of preventing block PPBs over-erasure.

Persistent Protection Bit Lock (PPB Lock)

The Persistent Protection Bit Lock (PPB Lock) is a global volatile bit. When set to "1", the PPBs cannot be changed. When cleared "0", the PPBs are changeable. There is only one PPB Lock bit per device. The PPB Lock is cleared after power-up or hardware reset. There is no command sequence to unlock the PPB Lock.

Dynamic Protection Bit (DYB)

A volatile protection bit is assigned for each block. After power-up or hardware reset, the contents of all DYBs is "0". Each DYB is individually modifiable through the DYB Write Command.

When the parts are first shipped, the PPBs are cleared, the DYBs are cleared, and PPB Lock is defaulted to power up in the cleared state - meaning the PPBs are changeable. When the device is first powered on the DYBs power up cleared (blocks not protected). The Protection State for each sector is determined by the logical OR of the PPB and the DYB related to that block. For the blocks that have the PPBs cleared, the DYBs control whether or not the block is protected or unprotected.

By issuing the DYB Write command sequences, the DYBs will be set or cleared, thus placing each block in the protected or unprotected state. These are the so-called Dynamic Locked or Unlocked states. They are called dynamic states because it is very easy to switch back and forth between the protected and unprotected conditions. This allows software to easily protect blocks against inadvertent changes yet does not prevent the easy removal of protection when changes are needed. The DYBs maybe set or cleared as often as needed.

The PPBs allow for a more static, and difficult to change, level of protection. The PPBs retain their state across power cycles because they are non-volatile. Individual PPBs are set with a command but must all be cleared as a group through a complex sequence of program and erasing commands. The PPBs are also limited to 100 erase cycles.

The PPB Lock bit adds an additional level of protection. Once all PPBs are programmed to the desired settings, the PPB Lock may be set to "1". Setting the PPB Lock disables all program and erase commands to the non-volatile PPBs. In effect, the PPB Lock Bit locks the PPBs into their current state. The only way to clear the PPB Lock is to go through a power cycle. System boot code can determine if any changes to the PPB are needed; for example, to allow new system code to be downloaded. If no changes are needed then the boot code can set the PPB Lock to disable any further changes to the PPBs during system operation.

The WP#/ACC write protect pin adds a final level of hardware protection to blocks BA141 and BA140, BA0 and BA1. When this pin is low it is not possible to change the contents of these blocks. These blocks generally hold system boot code. The WP#/ACC pin can prevent any changes to the boot code that could override the choices made while setting up block protection during system initialization.

For customers who are concerned about malicious viruses there is another level of security - the persistently locked state. To persistently protect a given block or block group, the PPBs associated with that block need to be set to "1". Once all PPBs are programmed to the desired settings, the PPB Lock should be set to "1". Setting the PPB Lock automatically disables all program and erase commands to the Non-Volatile PPBs. In effect, the PPB Lock "freezes" the PPBs into their current state. The only way to clear the PPB Lock is to go through a power cycle.

It is possible to have blocks that have been persistently locked, and blocks that are left in the dynamic state. The blocks in the dynamic state are all unprotected. If there is a need to protect some of them, a simple DYB Write command sequence is all that is necessary. The DYB write command for the dynamic blocks switch the DYBs to signify protected and unprotected, respectively. If there is a need to change the status of the persistently locked blocks, a few more steps are required. First, the PPB Lock bit must be disabled by either putting the device through a power-cycle, or hardware reset. The PPBs can then be changed to reflect the desired settings. Setting the PPB lock bit once again will lock the PPBs, and the device operates normally again.

The best protection is achieved by executing the PPB lock bit set command early in the boot code, and protect the boot code by holding WP#/ACC = VIL.

Table 8 contains all possible combinations of the DYB, PPB, and PPB lock relating to the status of the block.

In summary, if the PPB is set, and the PPB lock is set, the block is protected and the protection can not be removed until the next power cycle clears the PPB lock. If the PPB is cleared, the block can be dynamically locked or unlocked. The DYB then controls whether or not the block is protected or unprotected.

If the user attempts to program or erase a protected block, the device ignores the command and returns to read mode. A program command to a protected block enables status polling for approximately 1us before the device returns to read mode without having modified the contents of the protected block. An erase command to a protected block enables status polling for approximately 50us after which the device returns to read mode without having erased the protected block.

The programming of the DYB, PPB, and PPB lock for a given block can be verified by writing a DYB/PPB/PPB lock verify command to the device.

Persistent Block Protection Mode Locking Bit

Like the password mode locking bit, a Persistent Block Protection mode locking bit exists to guarantee that the device remain in software block protection. Once set, the Persistent Block Protection locking bit prevents programming of the password protection mode locking bit. This guarantees that a hacker could not place the device in password protection mode.

Password Protection Mode

The Password Block Protection Mode method allows an even higher level of security than the Persistent Block Protection Mode. There are two main differences between the Persistent Block Protection and the Password Block Protection Mode:

When the device is first powered on, or comes out of a reset cycle, the PPB Lock bit set to the locked state, rather than cleared to the unlocked state.

The only means to clear the PPB Lock bit is by writing a unique 64-bit Password to the device.

The Password Block Protection method is otherwise identical to the Persistent Block Protection method.

A 64-bit password is the only additional tool utilized in this method.

Once the Password Mode Locking Bit is set, the password is permanently set with no means to read, program, or erase it. The password is used to clear the PPB Lock bit. The Password Unlock command must be written to the flash, along with a password. The flash device internally compares the given password with the pre-programmed password. If they match, the PPB Lock bit is cleared, and the PPBs can be altered. If they do not match, the flash device does nothing. There is a built-in 2us delay for each "password check." This delay is intended to thwart any efforts to run a program that tries all possible combinations in order to crack the password.

Password and Password Mode Locking Bit

In order to select the Password block protection scheme, the customer must first program the password. The password may be correlated to the unique Electronic Serial Number (ESN) of the particular flash device. Each ESN is different for every flash device; therefore each password should be different for every flash device. While programming in the password region, the customer may perform Password Verify operations.

Once the desired password is programmed in, the customer must then set the Password Mode Locking Bit. This operation achieves two objectives:

Permanently sets the device to operate using the Password Protection Mode. It is not possible to reverse this function.

Disables all further commands to the password region. All program, and read operations are ignored.

Both of these objectives are important, and if not carefully considered, may lead to unrecoverable errors. The user must be sure that the Password Protection method is desired when setting the Password Mode Locking Bit. More importantly, the user must be sure that the password is correct when the Password Mode Locking Bit is set. Due to the fact that read operations are disabled, there is no means to verify what the password is afterwards. If the password is lost after setting the Password Mode Locking Bit, there will be no way to clear the PPB Lock bit.

The Password Mode Locking Bit, once set, prevents reading the 64-bit password on the DQ bus and further password programming. The Password Mode Locking Bit is not erasable. Once Password Mode Locking Bit is programmed, the Persistent Block Protection Locking Bit is disabled from programming, guaranteeing that no changes to the protection scheme are allowed.

64-bit Password

The 64-bit Password is located in its own memory space and is accessible through the use of the Password Program and Verify commands (see "Password Verify Command"). The password function works in conjunction with the Password Mode Locking Bit, which when set, prevents the Password Verify command from reading the contents of the password on the pins of the device.

Write Protect (WP#)

The Write Protect feature provides a hardware method of protecting the upper two and lower two blocks without using VID. This function is provided by the WP# pin and overrides the previously discussed "High Voltage Block Protection" section method.

If the system asserts VIL on the WP#/ACC pin, the device disables program and erase functions in the two outermost 4 Kword blocks on both ends of the flash array independent of whether it was previously protected or unprotected.

If the system asserts VIH on the WP#/ACC pin, the device reverts the upper two and lower two blocks to whether they were last set to be protected or unprotected. That is, block protection or unprotection for these sectors depends on whether they were last protected or unprotected using the method described in the "High Voltage Block Protection" section.

Persistent Protection Bit Lock

The Persistent Protection Bit (PPB) Lock is a volatile bit that reflects the state of the Password Mode Locking Bit after power-up reset. If the Password Mode Lock Bit is also set after a hardware reset (RESET# asserted) or a power-up reset, the ONLY means for clearing the PPB Lock Bit in Password Protection Mode is to issue the Password Unlock command. Successful execution of the Password Unlock command clears the PPB Lock Bit, allowing for block PPBs modifications. Asserting RESET#, taking the device through a power-on reset, or issuing the PPB Lock Bit Set command sets the PPB Lock Bit to a "1" when the Password Mode Lock Bit is not set.

If the Password Mode Locking Bit is not set, including Persistent Protection Mode, the PPB Lock Bit is cleared after power-up or hardware reset. The PPB Lock Bit is set by issuing the PPB Lock Bit Set command. Once set the only means for clearing the PPB Lock Bit is by issuing a hardware or power-up reset. The Password Unlock command is ignored in Persistent Protection Mode.

Master locking bit set

This Master locking bit can ensure that protected blocks be permanently unalterable.

Master locking bit is non-volatile bit. Master locking bit controls protection status of entire blocks.

The usage of the master locking bit command sequence is absolutely required to ensure full protection of data from future alterations. If master locking bit is set ("1"), entire blocks are permanently protected. They are not changed and altered by any future lock/unlock commands.

Anyone who uses this function needs much attention. Because there is no way to return to unlock status. Default status of master locking bit is unlock status("0").

If Master locking bit sets on unprotected block, the block still are remaining in status of unprotected block.

The unprotected block can be protected by protection command.

K8P3215UQB

FLASH MEMORY

Table 9. K8P3215UQB Boot Block/Block Addresses for Protection / Unprotection

Block	A20-A12	Block Size
BA0	00000000	4 Kwords
BA1	00000001	4 Kwords
BA2	00000010	4 Kwords
BA3	00000011	4 Kwords
BA4	00000100	4 Kwords
BA5	00000101	4 Kwords
BA6	00000110	4 Kwords
BA7	00000111	4 Kwords
BA8	00001XXX	32 Kwords
BA9	00010XXX	32 Kwords
BA10	00011XXX	32 Kwords
BA11-BA14	0001XXXX	128 (4x32) Kwords
BA15-BA18	0010XXXX	128 (4x32) Kwords
BA19-BA22	0011XXXX	128 (4x32) Kwords
BA23-BA26	0100XXXX	128 (4x32) Kwords
BA27-BA30	0101XXXX	128 (4x32) Kwords
BA31-BA34	0110XXXX	128 (4x32) Kwords
BA35-BA38	0111XXXX	128 (4x32) Kwords
BA39-BA42	1000XXXX	128 (4x32) Kwords
BA43-BA46	1001XXXX	128 (4x32) Kwords
BA47-BA50	1010XXXX	128 (4x32) Kwords
BA51-BA54	1011XXXX	128 (4x32) Kwords
BA55-BA58	1100XXXX	128 (4x32) Kwords
BA59-BA62	1101XXXX	128 (4x32) Kwords
BA63-BA66	1110XXXX	128 (4x32) Kwords
BA67	111100XXX	32 Kwords
BA68	111101XXX	32 Kwords
BA69	111110XXX	32 Kwords
BA70	111111000	4 Kwords
BA71	111111001	4 Kwords
BA72	111111010	4 Kwords
BA73	111111011	4 Kwords
BA74	111111100	4 Kwords
BA75	111111101	4 Kwords
BA76	111111110	4 Kwords
BA77	111111111	4 Kwords

K8P3215UQB

FLASH MEMORY

Table 10. Block Protection Command Sequences

Command Sequence		Cycl	1st Cycle	2nd Cycle	3rd Cycle	4th Cycle	5th Cycle	6th Cycle	7th Cycle
Password Program(1,2)	Add	4	555H	2AAH	555H	XX[0-3]H			
	Dat		AAH	55H	38H	PD[0-3]			
Password Verify(2,4,5)	Add	4	555H	2AAH	555H	PWA[0-3]			
	Dat		AAH	55H	C8H	PWD[0-3]			
Password Unlock(3,6,7)	Add	7	555H	2AAH	555H	PWA[0]	PWA[1]	PWA[2]	PWA[3]
	Dat		AAH	55H	28H	PWD[0]	PWD[1]	PWD[2]	PWD[3]
PPB Program(1,2,8)	Add	6	555H	2AAH	555H	(BA)WP	(BA)WP	(BA)WP	
	Dat		AAH	55H	60H	68H	48H	RD(0)	
Master locking bit Set	Add	3	555H	2AAH	555H				
	Dat		AAH	55H	F1H				
PPB Status	Add	4	555H	2AAH	555H	(BA)WP			
	Dat		AAH	55H	90H	RD(0)			
All PPB Erase(1,2,9,10)	Add	6	555H	2AAH	555H	WP	(BA)	(BA)WP	
	Dat		AAH	55H	60H	60H	40H	RD(0)	
PPB Lock Bit Set	Add	3	555H	2AAH	555H				
	Dat		AAH	55H	78H				
PPB Lock Bit Status(11)	Add	4	555H	2AAH	555H	BA			
	Dat		AAH	55H	58H	RD(1)			
DYB Write(3)	Add	4	555H	2AAH	555H	BA			
	Dat		AAH	55H	48H	X1H			
DYB Erase(3)	Add	4	555H	2AAH	555H	BA			
	Dat		AAH	55H	48H	X0H			
DYB Status(2)	Add	4	555H	2AAH	(DA)555H	BA			
	Dat		AAH	55H	58H	RD(0)			
PPMLB Program(1,2,8)	Add	6	555H	2AAH	555H	PL	PL	PL	
	Dat		AAH	55H	60H	68H	48H	RD(0)	
PPMLB Status(1)	Add	5	555H	2AAH	555H	PL	PL		
	Dat		AAH	55H	60H	48H	RD(0)		
SPMLB Program(1,2,8)	Add	6	555H	2AAH	555H	BL	BL	BL	
	Dat		AAH	55H	60H	68	48	RD(0)	
SPMLB Status(1)	Add	5	555H	2AAH	555H	BL	BL		
	Dat		AAH	55H	60H	48	RD(0)		

Legend:

DYB = Dynamic Protection Bit
 OW = Address (A7:A0) is (00011010)
 PD[3:0] = Password Data (1 of 4 portions)
 PPB = Persistent Protection Bit
 PWA = Password Address. A1:A0 selects portion of password.
 PWD = Password Data being verified.
 PL = Password Protection Mode Lock Address (A7:A0) is (00001010)
 RD(0) = Read Data DQ0 for protection indicator bit.
 RD(1) = Read Data DQ1 for PPB Lock status.
 BA = Block Address where security command applies. Address bits Amax:A12 uniquely select any block.
 BL = Persistent Protection Mode Lock Address (A7:A0) is (00010010)
 WP = PPB Address (A7:A0) is (00000010)

X = Don't care

PPMLB = Password Protection Mode Locking Bit

SPMLB = Persistent Protection Mode Locking Bit

Notes:

- See the description of bus operations.
 - All values are in hexadecimal.
 - Shaded cells in table denote read cycles. All other cycles are write operations.
 - During unlock and command cycles, when lower address bits are 555 or 2AAh as shown in table, address bits higher than A11 (except where BA is required) and data bits higher than DQ7 are don't cares.
1. The reset command returns device to reading array.
 2. Cycle 4 programs the addressed locking bit. Cycles 5 and 6 validate bit has been fully programmed when DQ0 = 1. If DQ0 = 0 in cycle 6, program command must be issued and verified again.
 3. Data is latched on the rising edge of WE#.
 4. Entire command sequence must be entered for each portion of password.
 5. Command sequence returns FFh if PPMLB is set.
 6. The password is written over four consecutive cycles, at addresses 0-3.
 7. 2 μ s timeout is required between any two portions of password.
 8. 100 μ s timeout is required between cycles 4 and 5.
 9. 1.2 ms timeout is required between cycles 4 and 5.
 10. Cycle 4 erases all PPBs. Cycles 5 and 6 validate bits have been fully erased when DQ0 = 0. If DQ0 = 1 in cycle 6, erase command must be issued and verified again. Before issuing erase command, all PPBs should be programmed to prevent PPB overerasure.
 11. DQ1 = 1 if PPB locked, 0 if unlocked.

K8P3215UQB

FLASH MEMORY

Table 11. Common Flash Memory Interface Code

Description	Addresses (Word Mode)	Data
Query Unique ASCII string "QRY"	10H 11H 12H	0051H 0052H 0059H
Primary OEM Command Set	13H 14H	0002H 0000H
Address for Primary Extended Table	15H 16H	0040H 0000H
Alternate OEM Command Set (00h = none exists)	17H 18H	0000H 0000H
Address for Alternate OEM Extended Table (00h = none exists)	19H 1AH	0000H 0000H
Vcc Min. (write/erase) D7-D4: volt, D3-D0: 100 millivolt	1BH	0027H
Vcc Max. (write/erase) D7-D4: volt, D3-D0: 100 millivolt	1CH	0036H
Vpp Min. voltage(00H = no Vpp pin present)	1DH	0000H
Vpp Max. voltage(00H = no Vpp pin present)	1EH	0000H
Typical timeout per single word write 2 ^N us	1FH	0003H
Typical timeout for Min. size buffer write 2 ^N us(00H = not supported)	20H	0000H
Typical timeout per individual block erase 2 ^N ms	21H	0009H
Typical timeout for full chip erase 2 ^N ms(00H = not supported)	22H	0000H
Max. timeout for word write 2 ^N times typical	23H	0004H
Max. timeout for buffer write 2 ^N times typical	24H	0000H
Max. timeout per individual block erase 2 ^N times typical	25H	0004H
Max. timeout for full chip erase 2 ^N times typical(00H = not supported)	26H	0000H
Device Size = 2 ^N byte	27H	0016H
Flash Device Interface description	28H 29H	0001H 0000H
Max. number of byte in multi-byte write = 2 ^N	2AH 2BH	0000H 0000H
Number of Erase Block Regions within device	2CH	0003H
Erase Block Region 1 Information	2DH 2EH 2FH 30H	0007H 0000H 0020H 0000H
Erase Block Region 2 Information	31H 32H 33H 34H	003DH 0000H 0000H 0001H
Erase Block Region 3 Information	35H 36H 37H 38H	0007H 0000H 0020H 0000H
Erase Block Region 4 Information	39H 3AH 3BH 3CH	0000H 0000H 0000H 0000H

K8P3215UQB**FLASH MEMORY****Table 11. Common Flash Memory Interface Code**

Description	Addresses (Word Mode)	Data
Query-unique ASCII string "PRI"	40H 41H 42H	0050H 0052H 0049H
Major version number, ASCII	43H	0030H
Minor version number, ASCII	44H	0030H
Address Sensitive Unlock(Bits 1-0) 0 = Required, 1= Not Required Silcon Revision Number(Bits 7-2)	45H	0000H
Erase Suspend 0 = Not Supported, 1 = To Read Only, 2 = To Read & Write	46H	0002H
Block Protect 00 = Not Supported, 01 = Supported	47H	0001H
Block Temporary Unprotect 00 = Not Supported, 01 = Supported	48H	0001H
Block Protect/Unprotect scheme, 00 = Not Supported, 01 = Supported	49H	0001H
Simultaneous Operation 00 = Not Supported, 01 = Supported	4AH	0001H
Burst Mode Type 00 = Not Supported, 01 = Supported	4BH	0000H
Page Mode Type 00 = Not Supported, 01 = 4 Word Page 02 = 8 Word Page	4CH	0002H
ACC(Acceleration) Supply Minimum 00 = Not Supported, D7 - D4 : Volt, D3 - D0 : 100mV	4DH	0085H
ACC(Acceleration) Supply Maximum 00 = Not Supported, D7 - D4 : Volt, D3 - D0 : 100mV	4EH	0095H
Top/Bottom Boot Block Flag 02H = Bottom Boot Device, 03H = Top Boot Device, 04H = Top and Bottom Device	4FH	0004H

DEVICE STATUS FLAGS

The K8P3215UQB has means to indicate its status of operation in the bank where a program or erase operation is in processes. Address must include bank address being executed internal routine operation. The status is indicated by raising the device status flag via corresponding DQ pins or the RY/ BY pin. The corresponding DQ pins are DQ7, DQ6, DQ5, DQ3 and DQ2. The statuses are as follows :

Table 12. Hardware Sequence Flags

	Status	DQ7	DQ6	DQ5	DQ3	DQ2	RY/BY	
In Progress	Programming	$\overline{\text{DQ7}}$	Toggle	0	0	1	0	
	Block Erase or Chip Erase	0	Toggle	0	1	Toggle	0	
	Erase Suspend Read	Erase Suspended Block	1	1	0	0	Toggle (Note 1)	1
	Erase Suspend Read	Non-Erase Suspended Block	Data	Data	Data	Data	Data	1
	Erase Suspend Program	Non-Erase Suspended Block	$\overline{\text{DQ7}}$	Toggle	0	0	1	0
	Program Suspend Read	Program Suspended Block	DQ7	1	0	0	Toggle (Note 1)	1
	Program Suspend Read	Non-Program Suspended Block	Data	Data	Data	Data	Data	1
Exceeded Time Limits	Programming	$\overline{\text{DQ7}}$	Toggle	1	0	No Toggle	0	
	Block Erase or Chip Erase	0	Toggle	1	1	(Note 2)	0	
	Erase Suspend Program	$\overline{\text{DQ7}}$	Toggle	1	0	No Toggle	0	

Notes :

1. DQ2 will toggle when the device performs successive read operations from the erase/program suspended block.
2. If DQ5 is High (exceeded timing limits), successive reads from a problem block will cause DQ2 to toggle.

DQ7 : Data Polling

When an attempt to read the device is made while executing the Internal Program, the complement of the data is written to DQ7 as an indication of the Routine in progress. When the Routine is completed an attempt to access to the device will produce the true data written to DQ7. When a user attempts to read the block being erased, DQ7 will be low. If the device is placed in the Erase/Program Suspend Mode, the status can be detected via the DQ7 pin. If the system tries to read an address which belongs to a block that is being erase suspended, DQ7 will be high. And, if the system tries to read an address which belongs to a block that is being program suspended, the output will be the true data of DQ7 itself. If a non-erase-suspended or non-program-suspended block address is read, the device will produce the true data to DQ7. If an attempt is made to program a protected block, DQ7 outputs complements the data for approximately 1µs and the device then returns to the Read Mode without changing data in the block. If an attempt is made to erase a protected block, DQ7 outputs complement data in approximately 100us and the device then returns to the Read Mode without erasing the data in the block.

DQ6 : Toggle Bit

Toggle bit is another option to detect whether an Internal Routine is in progress or completed. Once the device is at a busy state, DQ6 will toggle. Toggling DQ6 will stop after the device completes its Internal Routine. If the device is in the Erase/Program Suspend Mode, an attempt to read an address that belongs to a block that is being erased or programmed will produce a high output of DQ6. If an address belongs to a block that is not being erased or programmed, toggling is halted and valid data is produced at DQ6. If an attempt is made to program a protected block, DQ6 toggles for approximately 1us and the device then returns to the Read Mode without changing the data in the block. If an attempt is made to erase a protected block, DQ6 toggles for approximately 100µs and the device then returns to the Read Mode without erasing the data in the block. #OE or #CE should be toggled in each toggle bit status read.

DQ5 : Exceed Timing Limits

If the Internal Program/Erase Routine extends beyond the timing limits, DQ5 will go High, indicating program/erase failure.

DQ3 : Block Erase Timer

The status of the multi-block erase operation can be detected via the DQ3 pin. DQ3 will go High if 50µs of the block erase time window expires. In this case, the Internal Erase Routine will initiate the erase operation. Therefore, the device will not accept further write commands until the erase operation is completed. DQ3 is Low if the block erase time window is not expired. Within the block erase time window, an additional block erase command (30H) can be accepted. To confirm that the block erase command has been accepted, the software may check the status of DQ3 following each block erase command.

DQ2 : Toggle Bit 2

The device generates a toggling pulse in DQ2 only if an Internal Erase Routine or an Erase/Program Suspend is in progress. When the device executes the Internal Erase Routine, DQ2 toggles only if an erasing bank is read. Although the Internal Erase Routine is in the Exceeded Time Limits, DQ2 toggles only if an erasing block in the Exceeded Time Limits is read. When the device is in the Erase/Program Suspend mode, DQ2 toggles only if an address in the erasing or programming block is read. If a non-erasing or non-programmed block address is read during the Erase/Program Suspend mode, then DQ2 will produce valid data. DQ2 will go High if the user tries to program a non-erase suspend block while the device is in the Erase Suspend mode. #OE or #CE should be toggled in each toggle bit status read.

RY/BY : Ready/Busy

The K8P3215UQB has a Ready / Busy output that indicates either the completion of an operation or the status of Internal Algorithms. If the output is Low, the device is busy with either a program or an erase operation. If the output is High, the device is ready to accept any read/write or erase operation. When the RY/ BY pin is low, the device will not accept any additional program or erase commands with the exception of the Erase Suspend command. If the K8P3215UQB is placed in an Erase Suspend mode, the RY/ BY output will be High. For programming, the RY/ BY is valid (RY/ BY = 0) after the rising edge of the fourth WE pulse in the four write pulse sequence. For Chip Erase, RY/ BY is also valid after the rising edge of WE pulse in the six write pulse sequence. For Block Erase, RY/ BY is also valid after the rising edge of the sixth WE pulse. The pin is an open drain output, allowing two or more Ready/ Busy outputs to be OR-tied. An appropriate pull-up resistor is required for proper operation.

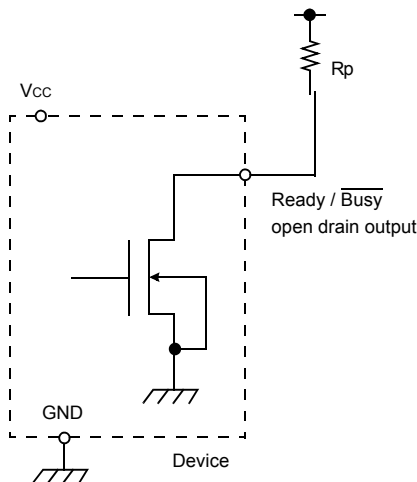

$$R_p = \frac{V_{cc} (\text{Max.}) - V_{OL} (\text{Max.})}{I_{OL} + \sum I_L} = \frac{3.2 \text{ V}}{2.1\text{mA} + \sum I_L}$$

where $\sum I_L$ is the sum of the input currents of all devices tied to the Ready / Busy pin.

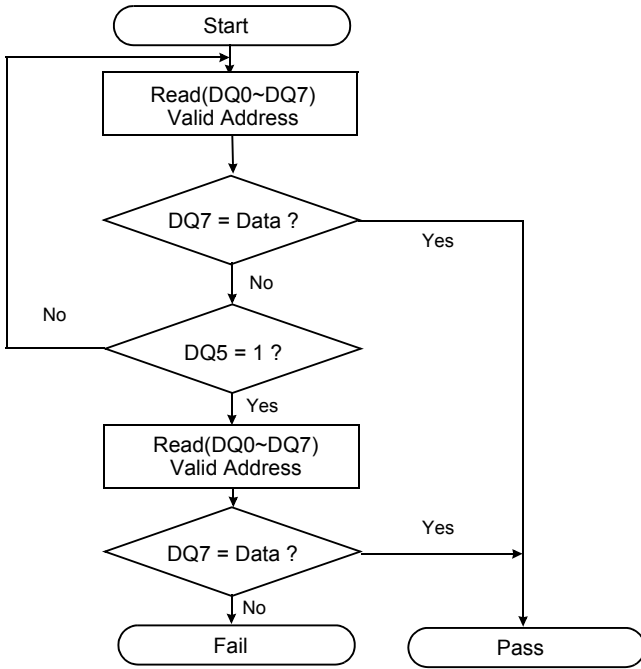

Figure 9. Data Polling Algorithms

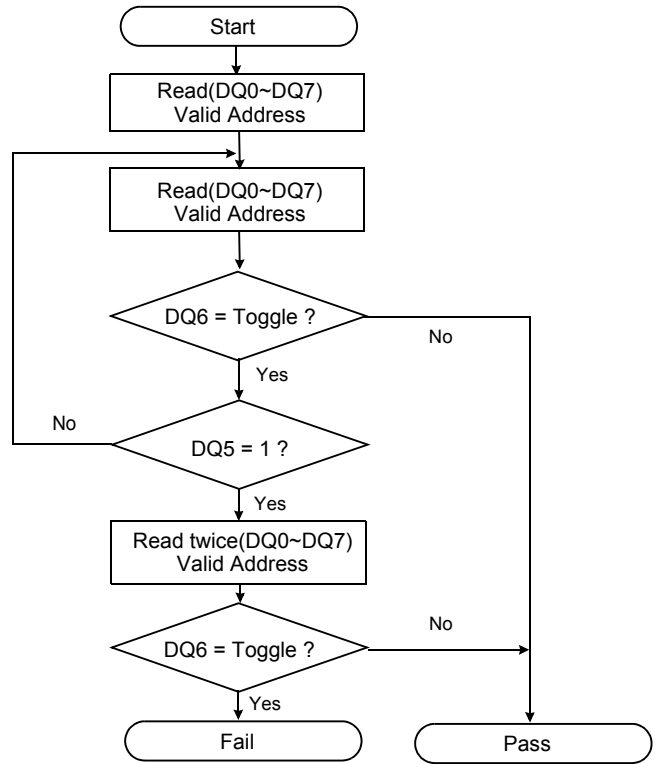

Figure 10. Toggle Bit Algorithms

K8P3215UQB

FLASH MEMORY

ABSOLUTE MAXIMUM RATINGS

Parameter	Symbol	Rating	Unit
Voltage on any pin relative to Vss	Vcc	-0.5 to +4.0	V
	A9, RESET	-0.5 to +9.5	
	WP/ACC	-0.5 to +9.5	
	All Other Pins	-0.5 to +2.5	
Temperature Under Bias	Commercial	-10 to +125	°C
	Extended	-25 to +125	
Storage Temperature	Tstg	-65 to +150	°C
Short Circuit Output Current	Ios	5	mA
Operating Temperature	TA (Commercial)	0 to +70	°C
	TA (Extended Temp.)	-25 to +85	°C

Notes :

- Minimum DC voltage is -0.5V on Input/ Output pins. During transitions, this level may fall to -2.0V for periods <20ns. Maximum DC voltage on input / output pins is Vcc+0.5V which, during transitions, may overshoot to Vcc+2.0V for periods <20ns.
- Minimum DC voltage is -0.5V on A9, RESET and WP/ACC pins. During transitions, this level may fall to -2.0V for periods <20ns. Maximum DC voltage on A9, RESET, WP/ACC pins is 9.5V which, during transitions, may overshoot to 14.0V for periods <20ns.
- Permanent device damage may occur if ABSOLUTE MAXIMUM RATINGS are exceeded. Functional operation should be restricted to the conditions detailed in the operational sections of this data sheet. Exposure to absolute maximum rating conditions for extended periods may affect reliability.

RECOMMENDED OPERATING CONDITIONS (Voltage reference to GND)

Parameter	Symbol	Min	Typ.	Max	Unit
Supply Voltage	Vcc	2.7	3.0	3.6	V
Supply Voltage	Vss	0	0	0	V

DC CHARACTERISTICS

Parameter	Sym- bol	Test Conditions	Min	Typ	Max	Unit	
Input Leakage Current	ILI	VIN=VSS to VCC, VCC=VCCmax	- 1.0	-	+ 1.0	µA	
A9,RESET Input Leakage Current	ILIT	VCC=VCCmax, A9, RESET=9.5V	-	-	35	µA	
WP/ACC Input Leakage Current	ILIW	VCC=VCCmax, WP/ACC=9.5V	-	-	35	µA	
Output Leakage Current	ILO	VOUT=VSS to VCC,VCC=VCC-max,OE=VIH	- 1.0	-	+ 1.0	µA	
Active Read Current (1)	Icc1	OE=VIH, VCC=VCCmax	10MHz	-	45	55	mA
			5MHz	-	20	30	
Active Write Current (2)	Icc2	CE=VIL, OE=VIH, WE=VIL	-	15	30	mA	
Read While Program Current (3)	Icc3	CE=VIL, OE=VIH (@10Mhz)	-	35	55	mA	
Read While Erase Current (3)	Icc4	CE=VIL, OE=VIH (@10Mhz)	-	35	55	mA	
Program While Erase Suspend Current	Icc5	CE=VIL, OE=VIH	-	15	35	mA	
Page Read Current	Icc6	OE=VIH, 8 word Page Read	-	10	15	mA	
ACC Accelerated Program Current	Iacc	CE=VIL, OE=VIH	-	15	30	mA	
Standby Current	ISB1	CE, RESET, WP/ACC= VIO± 0.3	-	15	30	µA	
Standby Current During Reset	ISB2	RESET= Vss± 0.3	-	15	30	µA	
Automatic Sleep Mode	ISB3	VIH=VIO ± 0.3V, VIL=Vss ±0.2V	-	15	30	µA	
Input Low Level	VIL	Vio=1.65~1.95V(2.7~3.6V)	-0.4(-0.5)	-	0.4 (Vccx0.2)	V	
Input High Level	VIH	Vio=1.65~1.95V(2.7~3.6V)	Vio -0.4 (Vccx0.8)	-	Vio+0.4 (Vcc+0.3)	V	
Voltage for WP/ACC Block Temporarily Unprotect and Program Acceleration (4)	VHH	Vcc = 3.0V ± 0.15V	8.5	-	9.5	V	

K8P3215UQB

FLASH MEMORY

Parameter	Symbol	Test Conditions	Min	Typ	Max	Unit
Voltage for Autoselect and Block Protect (4)	V _{ID}	V _{CC} = 3.0V ± 10%	8.5	-	9.5	V
Output Low Level	V _{OL}	I _{OL} = 100uA, V _{CC} =V _{CCmin} , V _{IO} =1.65~1.95V	-	-	0.1	V
		I _{OL} = 2.0mA, V _{CC} =V _{CCmin} , V _{IO} =2.7~3.6V	-	-	0.4	V
Output High Level	V _{OH}	I _{OH} = -100uA, V _{CC} =V _{CCmin} , V _{IO} =1.65~1.95V	V _{IO} -0.1	-	-	V
		I _{OH} = -2.0mA, V _{CC} =V _{CCmin} , V _{IO} =2.7~3.6V	2.4	-	-	V
Low VCC Lock-out Voltage (5)	V _{LKO}		2.3	-	2.5	V

Notes :

1. The I_{CC} current listed includes both the DC operating current and the frequency dependent component(at 10 MHz).
2. I_{CC} active during Internal Routine(program or erase) is in progress.
3. I_{CC} active during Read while Write is in progress.
4. The high voltage (V_{HH} or V_{ID}) must be used in the range of V_{CC} = 3.0V ± 0.15V
5. Not 100% tested.
6. Typical value are measured at V_{CC} = 3.0V, T_A=25°C , Not 100% tested.

CAPACITANCE(T_A = 25 °C, V_{CC} = 3.0V, f = 1.0MHz)

Item	Symbol	Test Condition	Min	Max	Unit
Input Capacitance	C _{IN}	V _{IN} =0V	-	10	pF
Output Capacitance	C _{OUT}	V _{OUT} =0V	-	10	pF
Control Pin Capacitance	C _{IN2}	V _{IN} =0V	-	10	pF

Note : Capacitance is periodically sampled and not 100% tested.

AC TEST CONDITION

Parameter	Value
Input Pulse Levels	0V to V _{CC}
Input Rise and Fall Times(V _{IO} =1.8,3.0V)	5ns
Input and Output Timing Levels	V _{CC} /2
Output Load	C _L = 30pF

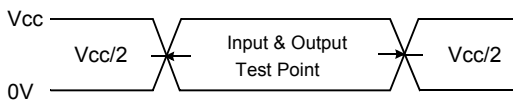

Input Pulse and Test Point

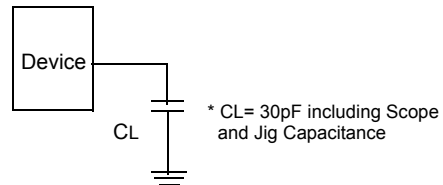

Output Load

AC CHARACTERISTICS

Read Operations

Parameter	Symbol	V _{CC} =2.7V~3.6V								Unit
		4A		4B		4C		4D		
		Min	Max	Min	Max	Min	Max	Min	Max	
Read Cycle Time (1)	t _{RC}	55	-	60	-	65	-	70	-	ns
Address Access Time	t _{AA}	-	55	-	60	-	65	-	70	ns
Chip Enable Access Time	t _{CE}	-	55	-	60	-	65	-	70	ns
Output Enable Time	t _{OE}	-	20	-	25	-	30	-	30	ns
Page Read Cycle Time (1)	t _{PRC}	20	-	25	-	25	-	30	-	ns
Page Address Access Time	t _{PA}	-	20	-	25	-	25	-	30	ns
$\overline{\text{CE}}$ & $\overline{\text{OE}}$ Disable Time (1)	t _{DF}	-	16	-	16	-	16	-	16	ns
Output Hold Time from Address, $\overline{\text{CE}}$ or $\overline{\text{OE}}$ (1)	t _{OH}	5	-	5	-	5	-	5	-	ns

Note : 1. Not 100% tested.

AC CHARACTERISTICS
Write(Erase/Program)Operations
Alternate WE Controlled Write

Parameter	Symbol	Vcc=2.7V ~ 3.6V								Unit	
		4A		4B		4C		4D			
		Min	Max	Min	Max	Min	Max	Min	Max		
Write Cycle Time (1)	tWC	55	-	60	-	65	-	70	-	ns	
Address Setup Time	tAS	0	-	0	-	0	-	0	-	ns	
	tASO	15	-	15	-	15	-	15	-	ns	
Address Hold Time	tAH	30	-	35	-	35	-	35	-	ns	
	tAHT	0	-	0	-	0	-	0	-	ns	
Data Setup Time	tDS	25	-	30	-	30	-	30	-	ns	
Data Hold Time	tDH	0	-	0	-	0	-	0	-	ns	
Output Enable Setup Time (1)	tOES	0	-	0	-	0	-	0	-	ns	
Output Enable Hold	Read (1)	tOE1	0	-	0	-	0	-	0	-	ns
	Toggle and Data Polling (1)	tOE2	10	-	10	-	10	-	10	-	ns
CE Setup Time	tCS	0	-	0	-	0	-	0	-	ns	
CE Hold Time	tCH	0	-	0	-	0	-	0	-	ns	
Write Pulse Width	tWP	35	-	35	-	35	-	35	-	ns	
Write Pulse Width High	tWPH	20	-	25	-	25	-	25	-	ns	
Programming Operation	tPGM	6(typ.)		6(typ.)		6(typ.)		6(typ.)		μs	
Accelerated Programming Operation	tACCPGM	6(typ.)		6(typ.)		6(typ.)		6(typ.)		μs	
Accelerated Quad word Programming Operation	tACCPGM_QUAD	1.5(typ.)		1.5(typ.)		1.5(typ.)		1.5(typ.)		μs	
Block Erase Operation (2)	tBERS	0.7(typ.)		0.7(typ.)		0.7(typ.)		0.7(typ.)		sec	
Vcc Set Up Time	tVCS	50	-	50	-	50	-	50	-	μs	
Write Recovery Time from RY/BY	tRB	0	-	0	-	0	-	0	-	ns	
RESET High Time Before Read	tRH	50	-	50	-	50	-	50	-	ns	
RESET to Power Down Time	tRPD	20	-	20	-	20	-	20	-	μs	
Program/Erase Valid to RY/BY Delay	tBUSY	35	90	35	90	35	90	35	90	ns	
Vio Rising and Falling Time	tVID	500	-	500	-	500	-	500	-	ns	
RESET Pulse Width	tRP	500	-	500	-	500	-	500	-	ns	
RESET Low to RY/BY High	tRRB	-	20	-	20	-	20	-	20	μs	
RESET Setup Time for Temporary Unprotect	tRSP	4	-	4	-	4	-	4	-	μs	
RESET Low Setup Time	tRSTS	500	-	500	-	500	-	500	-	ns	
RESET High to Address Valid	tRSTW	200	-	200	-	200	-	200	-	ns	
Read Recovery Time Before Write	tGHWL	0	-	0	-	0	-	0	-	ns	
CE High during toggling bit polling	tCEPH	20	-	20	-	20	-	20	-	ns	
OE High during toggling bit polling	tOEPH	10	-	10	-	10	-	10	-	ns	

Notes : 1. Not 100% tested.
 2. The duration of the Program or Erase operation varies and is calculated in the internal algorithms.

AC CHARACTERISTICS

Write(Erase/Program)Operations

Alternate CE Controlled Writes

Parameter	Symbol	V _{CC} =2.7V ~ 3.6V								Unit	
		4A		4B		4C		4D			
		Min	Max	Min	Max	Min	Max	Min	Max		
Write Cycle Time (1)	t _{WC}	55	-	60	-	65	-	70	-	ns	
Address Setup Time	t _{AS}	0	-	0	-	0	-	0	-	ns	
Address Hold Time	t _{AH}	30	-	35	-	35	-	35	-	ns	
Data Setup Time	t _{DS}	25	-	30	-	30	-	30	-	ns	
Data Hold Time	t _{DH}	0	-	0	-	0	-	0	-	ns	
Output Enable Setup Time (1)	t _{OES}	0	-	0	-	0	-	0	-	ns	
Output Enable Hold	Read (1)	t _{OE1}	0	-	0	-	0	-	0	-	ns
	Toggle and Data Polling (1)	t _{OE2}	10	-	10	-	10	-	10	-	ns
\overline{WE} Setup Time	t _{WS}	0	-	0	-	0	-	0	-	ns	
\overline{WE} Hold Time	t _{WH}	0	-	0	-	0	-	0	-	ns	
\overline{CE} Pulse Width	t _{CP}	35	-	40	-	40	-	40	-	ns	
\overline{CE} Pulse Width High	t _{CPH}	20	-	25	-	25	-	25	-	ns	
Programming Operation	t _{PGM}	6(typ.)		6(typ.)		6(typ.)		6(typ.)		μs	
Accelerated Programming Operation	t _{ACCPGM}	6(typ.)		6(typ.)		6(typ.)		6(typ.)		μs	
Accelerated Quad word Programming Operation	t _{ACCPGM_QUAD}	1.5(typ.)		1.5(typ.)		1.5(typ.)		1.5(typ.)		μs	
Block Erase Operation (2)	t _{BERS}	0.7(typ.)		0.7(typ.)		0.7(typ.)		0.7(typ.)		sec	

Notes : 1. Not 100% tested.
2. This does not include the preprogramming time.

ERASE AND PROGRAM PERFORMANCE

Parameter	Limits			Unit	Comments
	Min	Typ	Max		
Block Erase Time	-	0.7	2	sec	Excludes 00H programming prior to erasure
Chip Erase Time	-	39	62.4	sec	
Word Programming Time	-	6	100	μs	Excludes system-level overhead
Accelerated Word Program Time	-	6	100	μs	
Accelerated Quad Word Program Time	-	1.5	-	μs	
Chip Programming Time (Normal)	-	12.6	25.2	sec	
Chip Programming Time (Acc. Quad)	-	3	-	sec	
Erase/Program Endurance	100,000	-	-	cycles	Minimum 100,000 cycles guaranteed

Notes : 1. 25 °C, V_{CC} = 3.0V 100,000 cycles, typical pattern.
2. System-level overhead is defined as the time required to execute the four bus cycle command necessary to program each word. In the preprogramming step of the Internal Erase Routine, all words are programmed to 00H before erasure.

SWITCHING WAVEFORMS
Conventional Read Operations

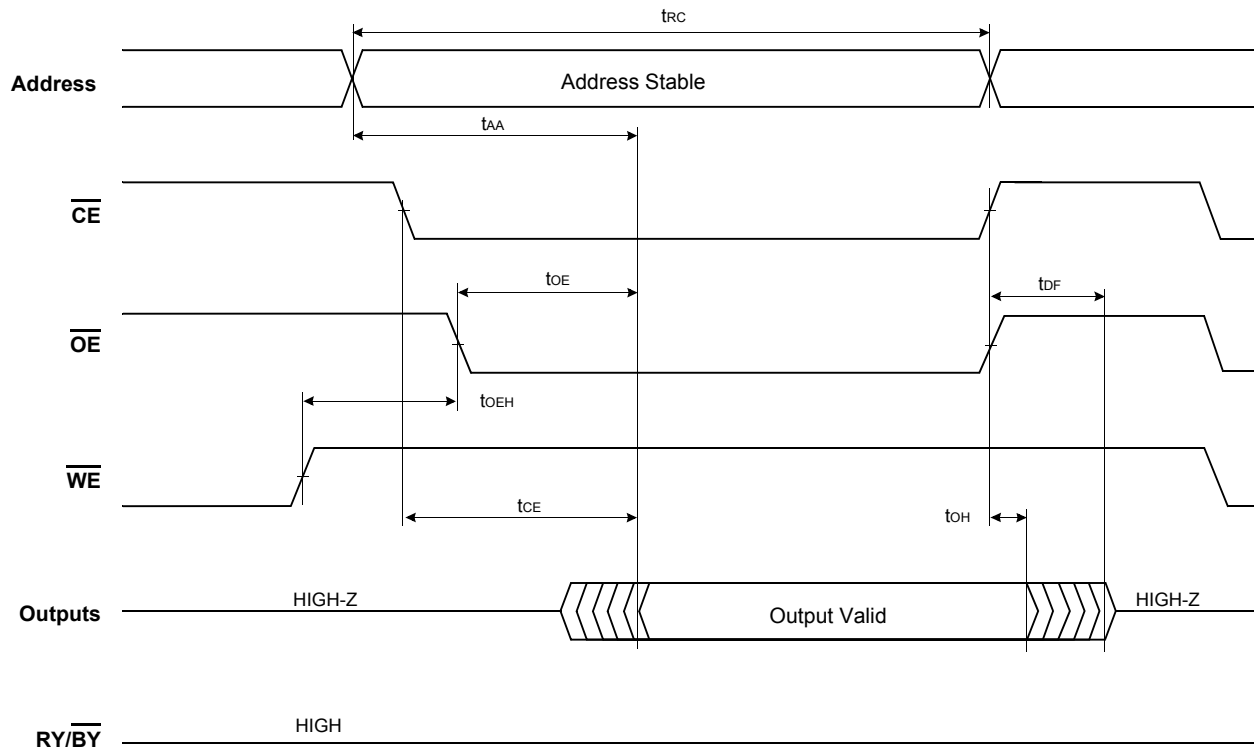

Figure 11. Conventional Read Operation Timings

Parameter	Symbol	4A		4B		4C		4D		Unit
		Min	Max	Min	Max	Min	Max	Min	Max	
Read Cycle Time	t_{RC}	55	-	60	-	65	-	70	-	ns
Address Access Time	t_{AA}	-	55	-	60	-	65	-	70	ns
Chip Enable Access Time	t_{CE}	-	55	-	60	-	65	-	70	ns
Output Enable Time	t_{OE}	-	20	-	25	-	30	-	30	ns
\overline{CE} & \overline{OE} Disable Time (1)	t_{DF}	-	16	-	16	-	16	-	16	ns
Output Hold Time from Address, \overline{CE} or \overline{OE}	t_{OH}	5	-	5	-	5	-	5	-	ns
\overline{OE} Hold Time	t_{OEH}	0	10	0	10	0	10	0	10	ns

Note : 1. Not 100% tested.

SWITCHING WAVEFORMS

Page Read Operations

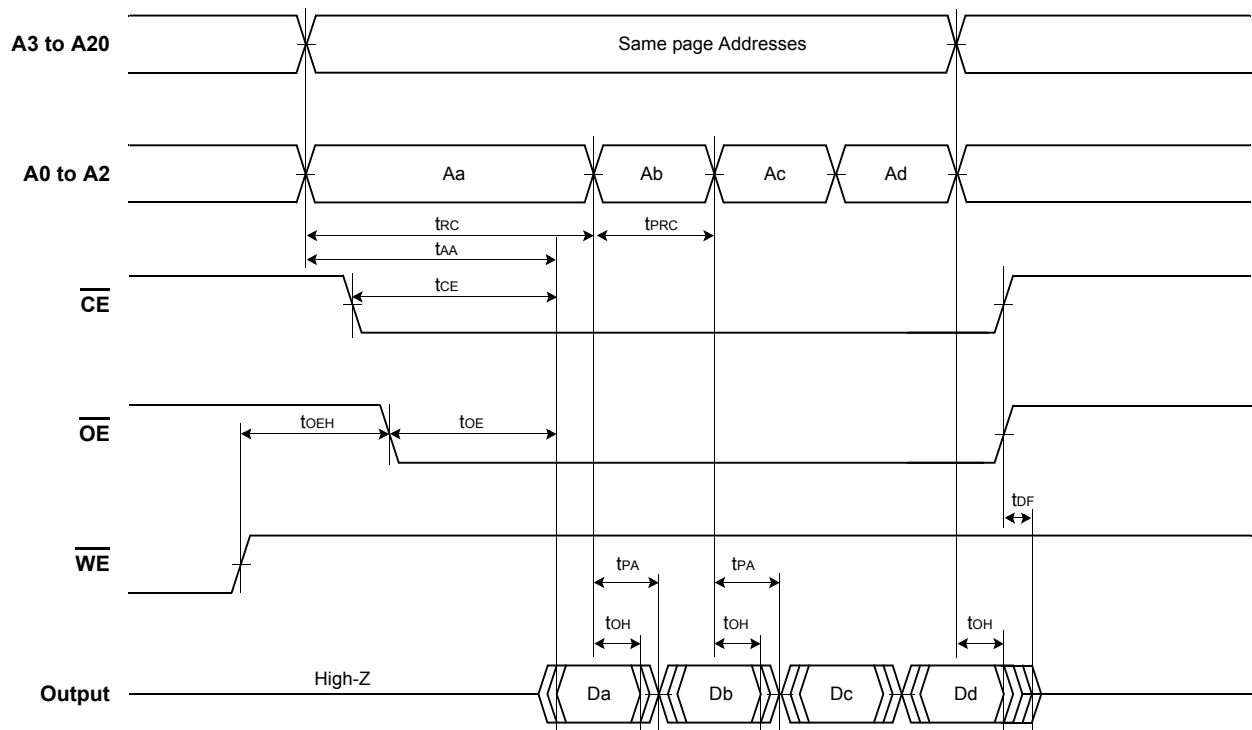

Figure 12. Page Read Operation Timings

Parameter	Symbol	4A		4B		4C		4D		Unit
		Min	Max	Min	Max	Min	Max	Min	Max	
Read Cycle Time	tRC	55	-	60	-	65	-	70	-	ns
Page Read Cycle Time	tPRC	20	-	25	-	25	-	30	-	ns
Address Access Time	tAA	-	55	-	60	-	65	-	70	ns
Page Address Access Time	tPA	-	20	-	25	-	25	-	30	ns
Chip Enable Access Time	tCE	-	55	-	60	-	65	-	70	ns
Output Enable Time	tOE	-	20	-	25	-	30	-	30	ns
CE & OE Disable Time (1)	tDF	-	16	-	16	-	16	-	16	ns
Output Hold Time from Address, CE or OE	tOH	5	-	5	-	5	-	5	-	ns
OE Hold Time	tOEH	0	-	0	-	0	-	0	-	ns

Note : 1. Not 100% tested.

SWITCHING WAVEFORMS

Hardware Reset/Read Operations

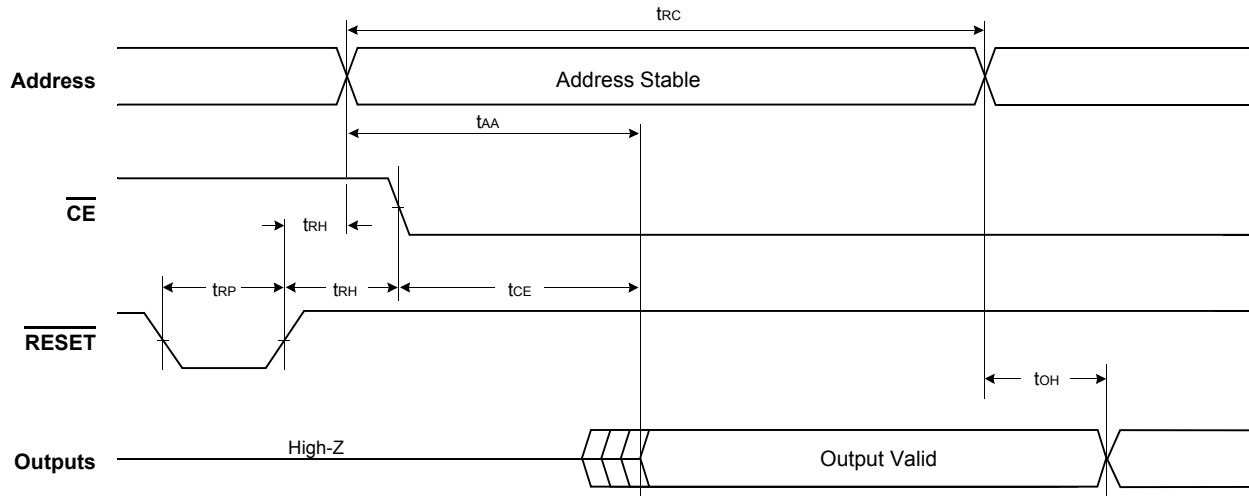
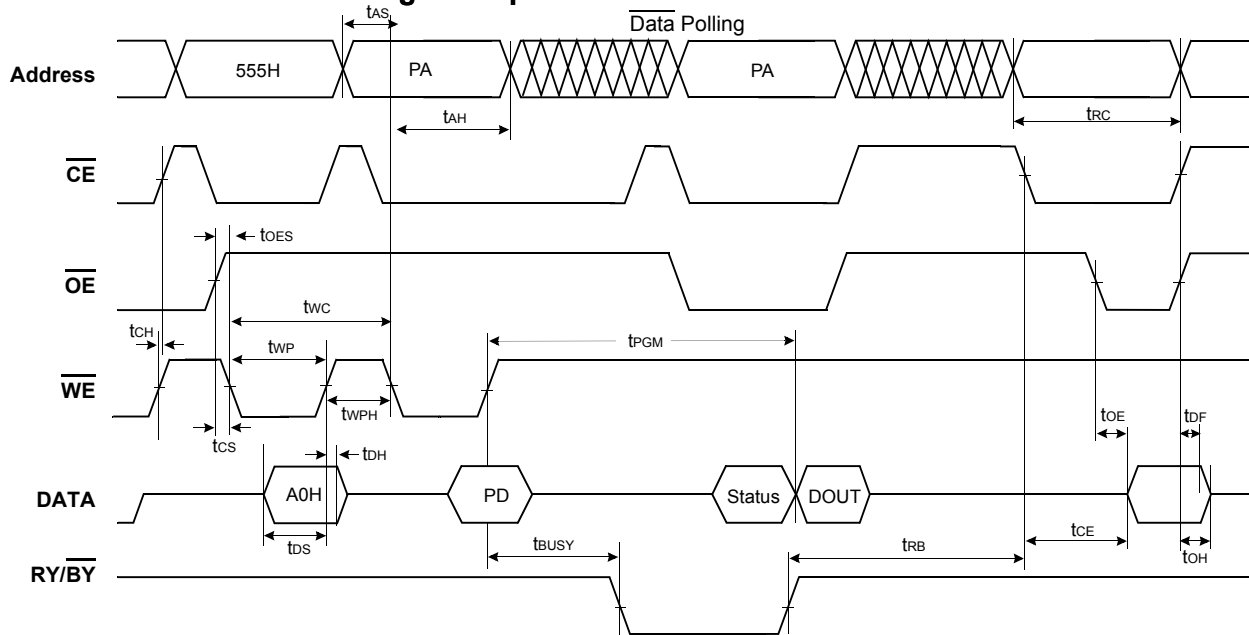

Figure 13. Hardware Reset/Read Operation Timings

Parameter	Symbol	4A		4B		4C		4D		Unit
		Min	Max	Min	Max	Min	Max	Min	Max	
Read Cycle Time	t_{RC}	55	-	60	-	65	-	70	-	ns
Address Access Time	t_{AA}	-	55	-	60	-	65	-	70	ns
Chip Enable Access Time	t_{CE}	-	55	-	60	-	65	-	70	ns
Output Hold Time from Address, \overline{CE} or \overline{OE}	t_{OH}	5	-	5	-	5	-	5	-	ns
\overline{RESET} Pulse Width	t_{RP}	500	-	500	-	500	-	500	-	ns
\overline{RESET} High Time Before Read	t_{RH}	50	-	50	-	50	-	50	-	ns

SWITCHING WAVEFORMS

Alternate WE Controlled Program Operations



- Notes : 1. $\overline{DQ7}$ is the output of the complement of the data written to the device.
 2. DOUT is the output of the data written to the device.
 3. PA : Program Address, PD : Program Data
 4. The illustration shows the last two cycles of the program command sequence.

Figure 14. Alternate WE Controlled Program Operation Timings

Parameter	Symbol	4A		4B		4C		4D		Unit
		Min	Max	Min	Max	Min	Max	Min	Max	
Write Cycle Time	tWC	55	-	60	-	65	-	70	-	ns
Address Setup Time	tAS	0	-	0	-	0	-	0	-	ns
Address Hold Time	tAH	30	-	35	-	35	-	35	-	ns
Data Setup Time	tDS	25	-	30	-	30	-	30	-	ns
Data Hold Time	tDH	0	-	0	-	0	-	0	-	ns
\overline{CE} Setup Time	tCS	0	-	0	-	0	-	0	-	ns
\overline{CE} Hold Time	tCH	0	-	0	-	0	-	0	-	ns
\overline{OE} Setup Time	tOES	0	-	0	-	0	-	0	-	ns
Write Pulse Width	tWP	35	-	35	-	35	-	35	-	ns
Write Pulse Width High	tWPH	20	-	25	-	25	-	25	-	ns
Programming Operation	tPGM	6(typ.)		6(typ.)		6(typ.)		6(typ.)		us
Accelerated Programming Operation	tACCPGM	6(typ.)		6(typ.)		6(typ.)		6(typ.)		μ s
Read Cycle Time	tRC	55	-	60	-	65	-	70	-	ns
Chip Enable Access Time	tCE	-	55	-	60	-	65	-	70	ns
Output Enable Time	tOE	-	20	-	25	-	30	-	30	ns
\overline{CE} & \overline{OE} Disable Time	tDF	-	16	-	16	-	16	-	16	ns
Output Hold Time from Address, \overline{CE} or \overline{OE}	tOH	5	-	5	-	5	-	5	-	ns
Program/Erased Valid to $\overline{RY/BY}$ Delay	tBUSY	35	90	35	90	35	90	35	90	ns
Recovery Time from $\overline{RY/BY}$	tRB	0	-	0	-	0	-	0	-	ns

SWITCHING WAVEFORMS

Alternate $\overline{\text{CE}}$ Controlled Program Operations

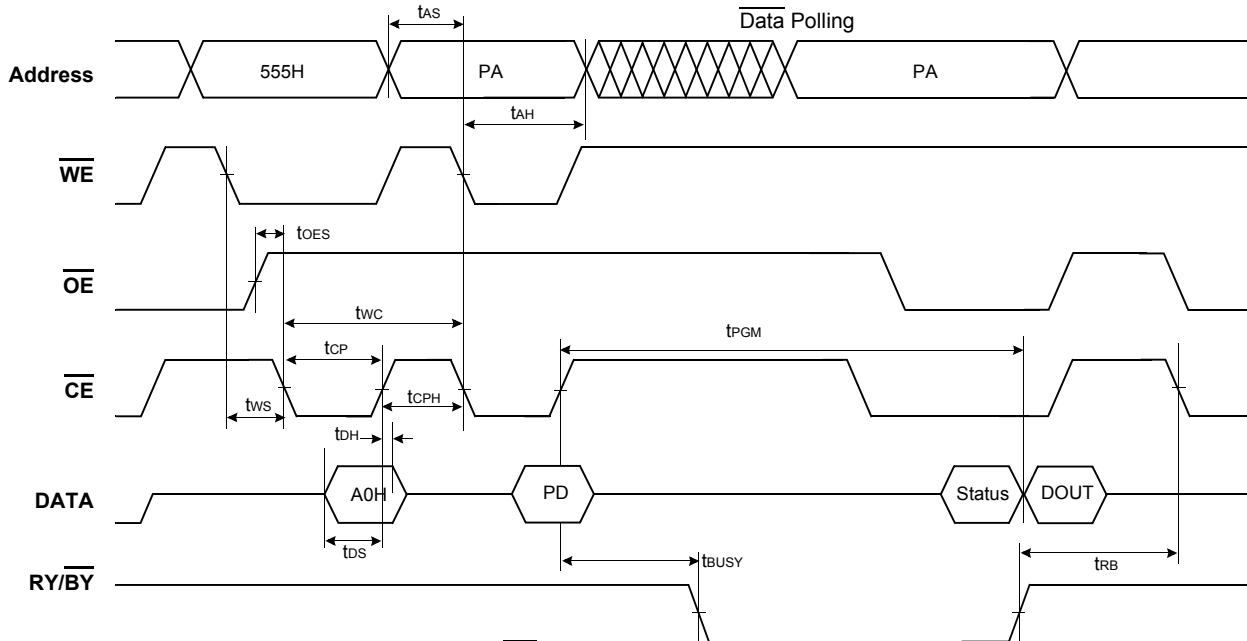

Figure 15. Alternate $\overline{\text{CE}}$ Controlled Program Operation Timings

Notes :

1. $\overline{\text{DQ7}}$ is the output of the complement of the data written to the device.
2. DOUT is the output of the data written to the device.
3. PA : Program Address, PD : Program Data
4. The illustration shows the last two cycles of the program command sequence.

Parameter	Symbol	4A		4B		4C		4D		Unit
		Min	Max	Min	Max	Min	Max	Min	Max	
Write Cycle Time	tWC	55	-	60	-	65	-	70	-	ns
Address Setup Time	tAS	0	-	0	-	0	-	0	-	ns
Address Hold Time	tAH	30	-	35	-	35	-	35	-	ns
Data Setup Time	tDS	25	-	30	-	30	-	30	-	ns
Data Hold Time	tDH	0	-	0	-	0	-	0	-	ns
$\overline{\text{OE}}$ Setup Time	tOES	0	-	0	-	0	-	0	-	ns
$\overline{\text{WE}}$ Setup Time	tWS	0	-	0	-	0	-	0	-	ns
$\overline{\text{WE}}$ Hold Time	tWH	0	-	0	-	0	-	0	-	ns
$\overline{\text{CE}}$ Pulse Width	tCP	35	-	40	-	40	-	40	-	ns
$\overline{\text{CE}}$ Pulse Width High	tCPH	20	-	25	-	25	-	25	-	ns
Programming Operation	tPGM	6(typ.)		6(typ.)		6(typ.)		6(typ.)		μs
Accelerated Programming Operation	tACCPGM	6(typ.)		6(typ.)		6(typ.)		6(typ.)		μs
Program/Erase Valid to RY/BY Delay	tBUSY	35	90	35	90	35	90	35	90	ns
Recovery Time from RY/BY	tRB	0	-	0	-	0	-	0	-	ns

SWITCHING WAVEFORMS
Chip/Block Erase Operations

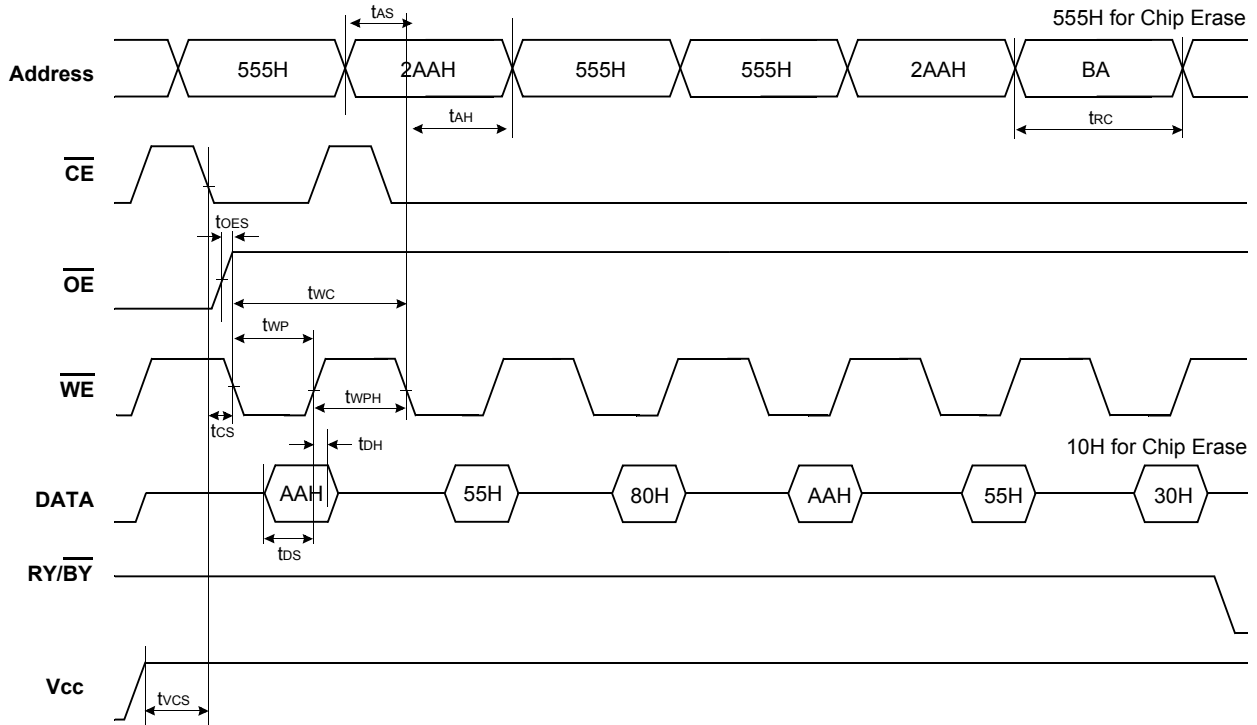

Figure 16. Chip/Block Erase Operation Timings

Note : BA : Block Address

Parameter	Symbol	4A		4B		4C		4D		Unit
		Min	Max	Min	Max	Min	Max	Min	Max	
Write Cycle Time	t _{WC}	55	-	60	-	65	-	70	-	ns
Address Setup Time	t _{AS}	0	-	0	-	0	-	0	-	ns
Address Hold Time	t _{AH}	30	-	35	-	35	-	35	-	ns
Data Setup Time	t _{DS}	25	-	30	-	30	-	30	-	ns
Data Hold Time	t _{DH}	0	-	0	-	0	-	0	-	ns
OE Setup Time	t _{OES}	0	-	0	-	0	-	0	-	ns
CE Setup Time	t _{CS}	0	-	0	-	0	-	0	-	ns
Write Pulse Width	t _{WP}	35	-	35	-	35	-	35	-	ns
Write Pulse Width High	t _{WPH}	20	-	25	-	25	-	25	-	ns
Read Cycle Time	t _{RC}	55	-	60	-	65	-	70	-	ns
V _{CC} Set Up Time	t _{vCS}	50	-	50	-	50	-	50	-	μs

SWITCHING WAVEFORMS
Read While Write Operations

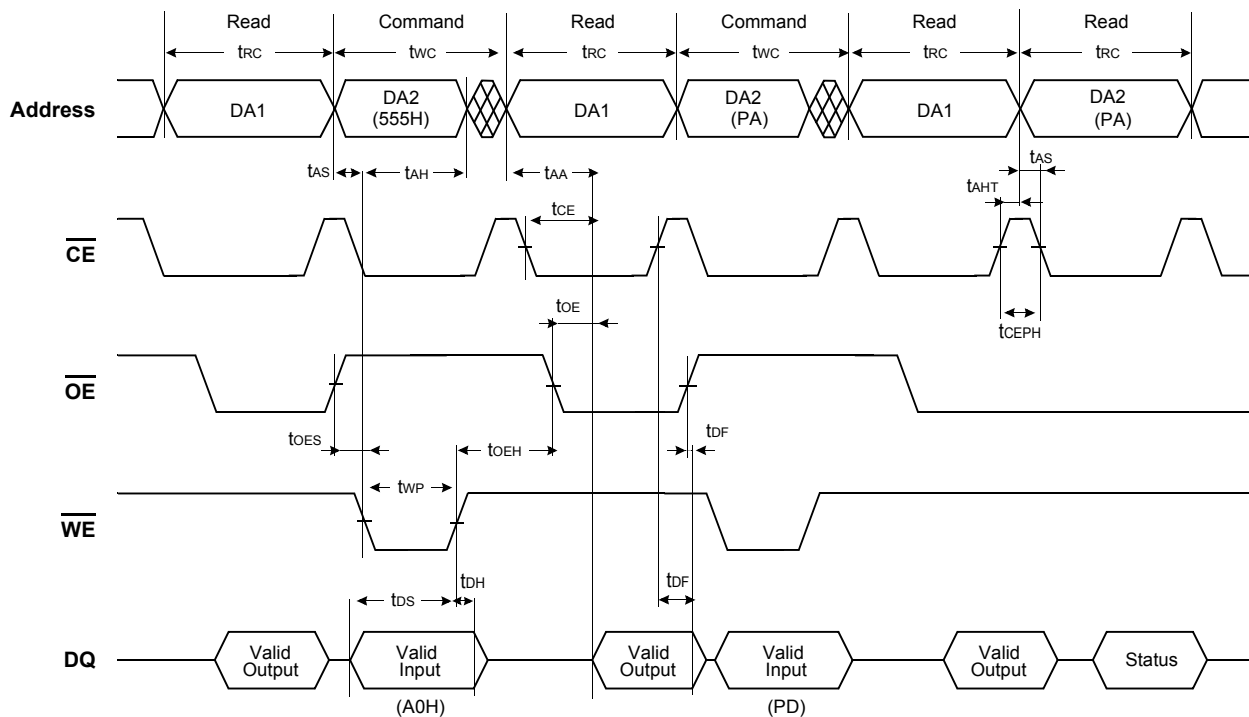

Figure 17. Read While Write Operation Timings

Note : This is an example in the program-case of the Read While Write function.

DA1 : Address of Bank1, DA2 : Address of Bank 2

PA = Program Address at one bank , RA = Read Address at the other bank, PD = Program Data In , RD = Read Data Out

Parameter	Symbol	4A		4B		4C		4D		Unit
		Min	Max	Min	Max	Min	Max	Min	Max	
Write Cycle Time	tWC	55	-	60	-	65	-	70	-	ns
Write Pulse Width	tWP	35	-	35	-	35	-	35	-	ns
Write Pulse Width High	tWPH	20	-	25	-	25	-	25	-	ns
Address Setup Time	tAS	0	-	0	-	0	-	0	-	ns
Address Hold Time	tAH	30	-	35	-	35	-	35	-	ns
Data Setup Time	tDS	25	-	30	-	30	-	30	-	ns
Data Hold Time	tDH	0	-	0	-	0	-	0	-	ns
Read Cycle Time	tRC	55	-	60	-	65	-	70	-	ns
Chip Enable Access Time	tCE	-	55	-	60	-	65	-	70	ns
Address Access Time	tAA	-	55	-	60	-	65	-	70	ns
Output Enable Access Time	tOE	-	20	-	25	-	30	-	30	ns
\overline{OE} Setup Time	tOES	0	-	0	-	0	-	0	-	ns
\overline{OE} Hold Time	tOEH	10	-	10	-	10	-	10	-	ns
\overline{CE} & \overline{OE} Disable Time	tDF	-	16	-	16	-	16	-	16	ns
Address Hold Time	tAHT	30	-	35	-	35	-	35	-	ns
\overline{CE} High during toggle bit polling	tCEPH	20	-	20	-	20	-	20	-	ns

SWITCHING WAVEFORMS

Data Polling During Internal Routine Operation

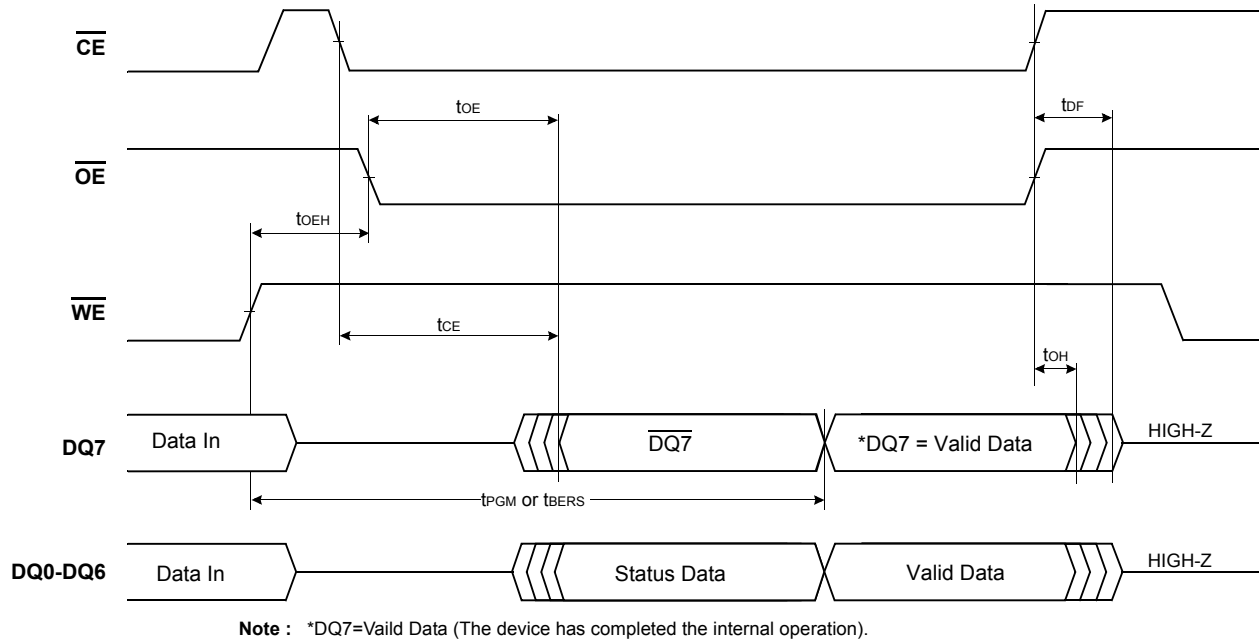

Figure 18. Data Polling During Internal Routine Operation Timings

RY/BY Timing Diagram During Program/Erase Operation

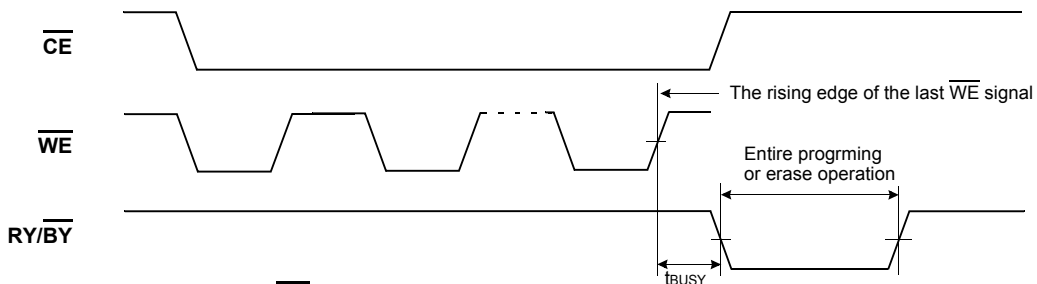
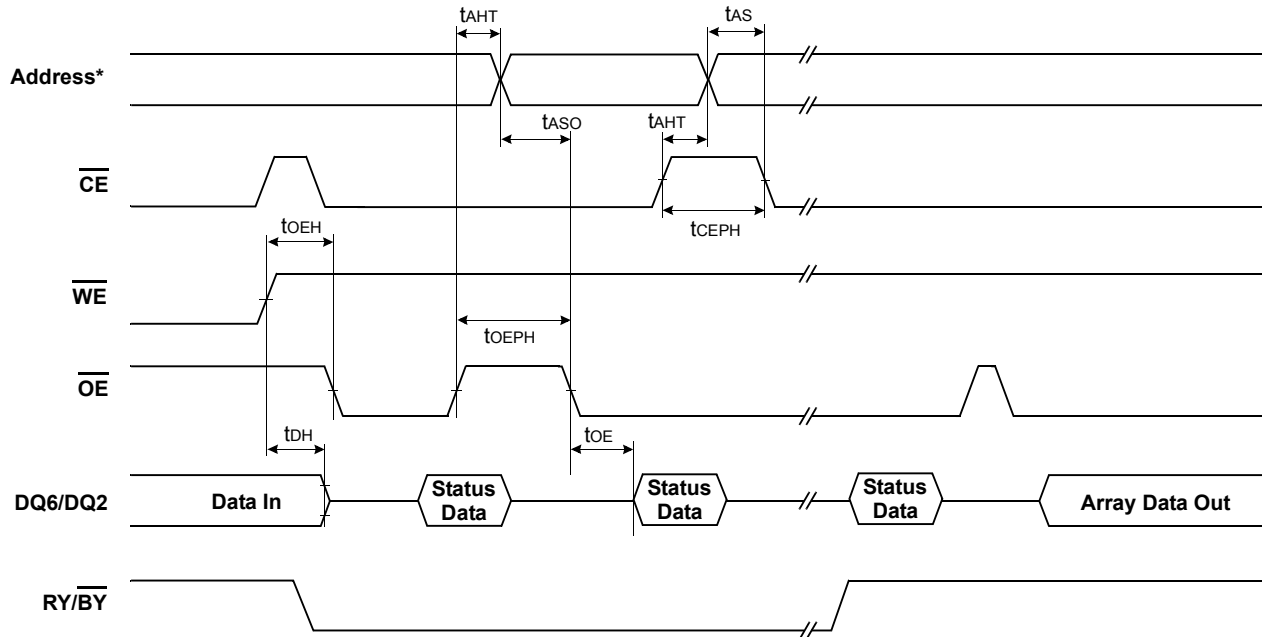

Figure 19. RY/BY Timing Diagram During Program/Erase Operation Timings

Parameter	Symbol	4A		4B		4C		4D		Unit
		Min	Max	Min	Max	Min	Max	Min	Max	
Program/Erase Valid to RY/BY Delay	t _{BUSY}	35	90	35	90	35	90	35	90	ns
Chip Enable Access Time	t _{CE}	-	55	-	60	-	65	-	70	ns
Output Enable Time	t _{OE}	-	20	-	25	-	30	-	30	ns
CE & OE Disable Time	t _{DF}	-	16	-	16	-	16	-	16	ns
Output Hold Time from Address, CE or OE	t _{OH}	5	-	5	-	5	-	5	-	ns
OE Hold Time	t _{OEH}	10	-	10	-	10	-	10	-	ns

SWITCHING WAVEFORMS

Toggle Bit During Internal Routine Operation



Note : Address for the write operation must include a bank address (A19~A20) where the data is written.

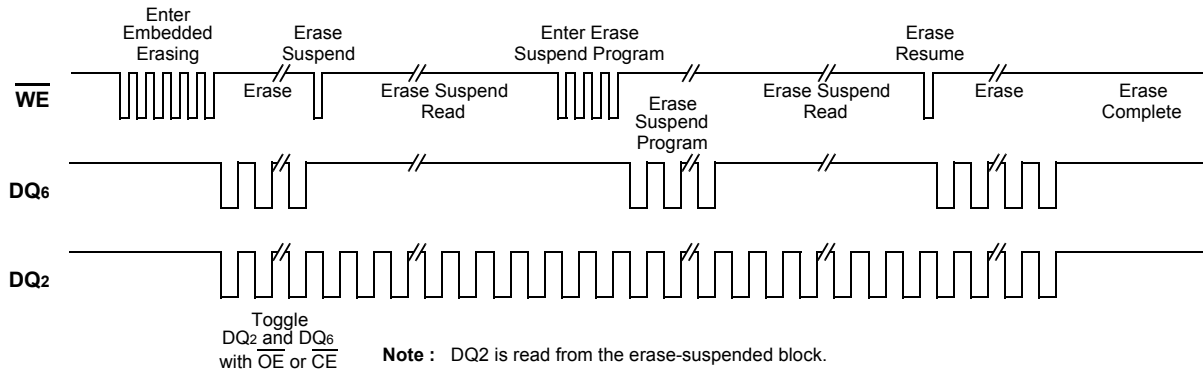
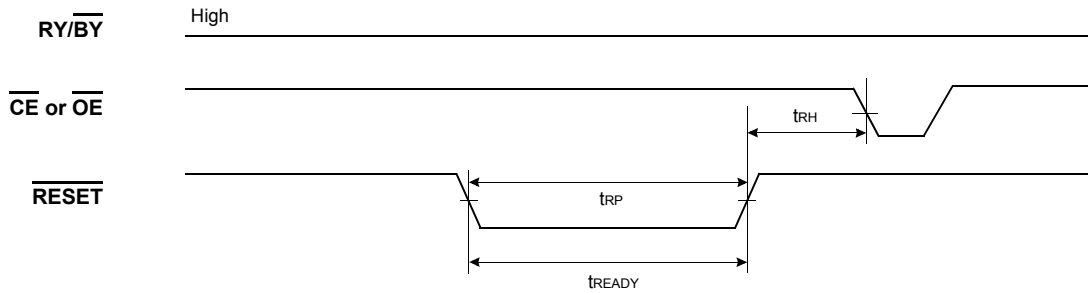

Figure 20. Toggle Bit During Internal Routine Operation Timings

Parameter	Symbol	4A		4B		4C		4D		Unit
		Min	Max	Min	Max	Min	Max	Min	Max	
Output Enable Access Time	tOE	-	20	-	25	-	30	-	30	ns
OE Hold Time	tOEHL	10	-	10	-	10	-	10	-	ns
Address Hold Time	taHT	30	-	35	-	35	-	35	-	ns
Address Setup	tASO	55	-	55	-	55	-	55	-	ns
Address Setup Time	tAS	0	-	0	-	0	-	0	-	ns
Data Hold Time	tDH	0	-	0	-	0	-	0	-	ns
CE High during toggle bit polling	tCEPH	20	-	20	-	20	-	20	-	ns
OE High during toggle bit polling	tOEHL	10	-	10	-	10	-	10	-	ns

SWITCHING WAVEFORMS

RESET Timing Diagram



Reset Timings NOT during Internal Routine

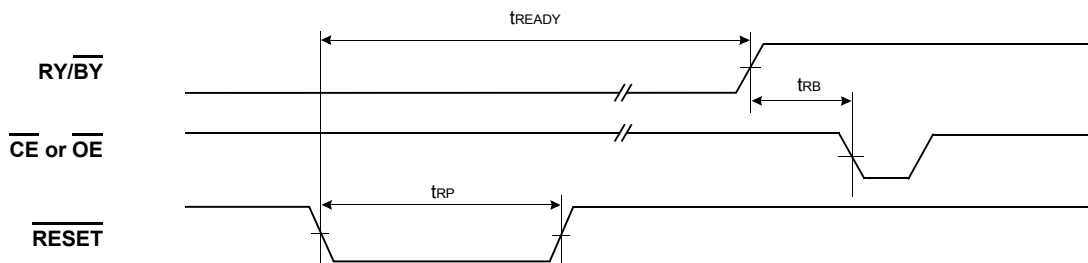

Reset Timings during Internal Routine

Power-up and RESET Timing Diagram

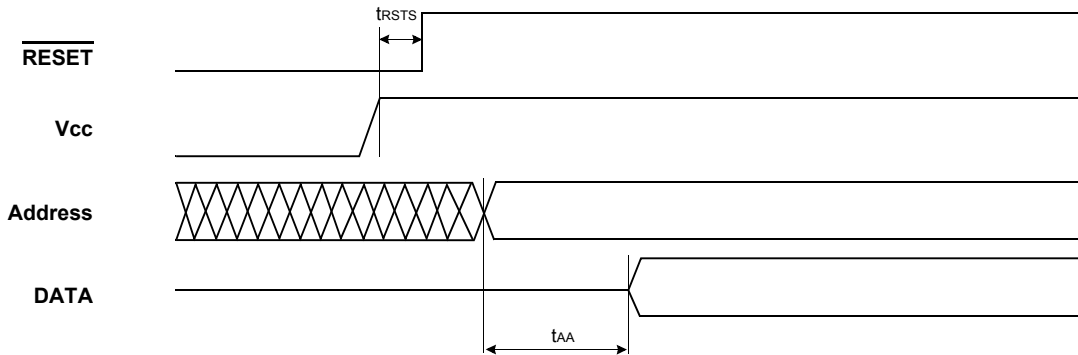
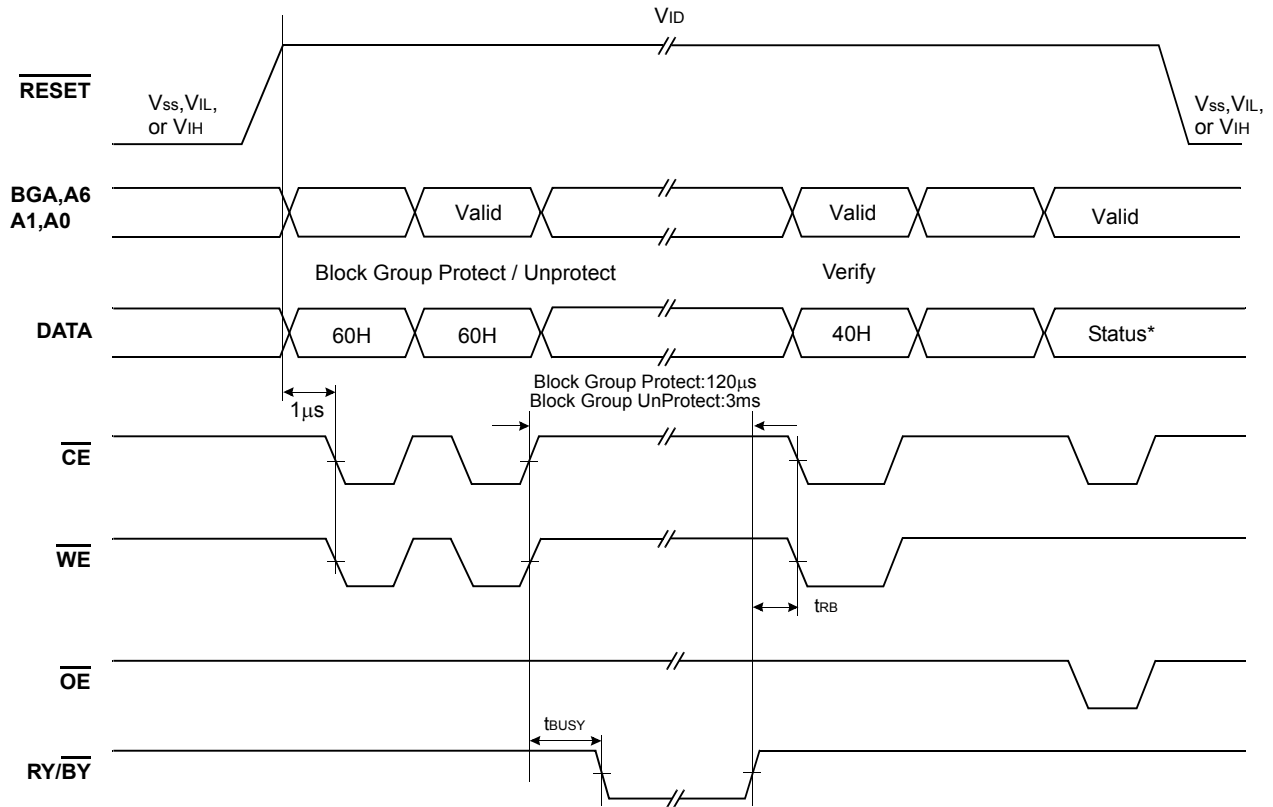

Figure 21. Power-up and RESET Timing Diagram

Parameter	Sym- bol	4A		4B		4C		4D		Unit
		Min	Max	Min	Max	Min	Max	Min	Max	
RESET Pulse Width	trP	500	-	500	-	500	-	500	-	ns
RESET Low to Valid Data (During Internal Routine)	tREADY	-	20	-	20	-	20	-	20	μs
RESET Low to Valid Data (Not during Internal Routine)	tREADY	-	500	-	500	-	500	-	500	ns
RESET High Time Before Read	trH	50	-	50	-	50	-	50	-	ns
RY/BY Recovery Time	trB	0	-	0	-	0	-	0	-	ns
RESET High to Address Valid	trSTW	200	-	200	-	200	-	200	-	ns
RESET Low Set-up Time	trSTS	500	-	500	-	500	-	500	-	ns

SWITCHING WAVEFORMS

Block Group Protect & Unprotect Operations



Notes : Block Group Protect (A6=V_{IL}, A1=V_{IH}, A0=V_{IL}), Status=01H
 Block Group Unprotect (A6=V_{IH}, A1=V_{IH}, A0=V_{IL}), Status=00H
 BGA = Block Group Address (A12 ~ A20)

Temporary Block Group Unprotect

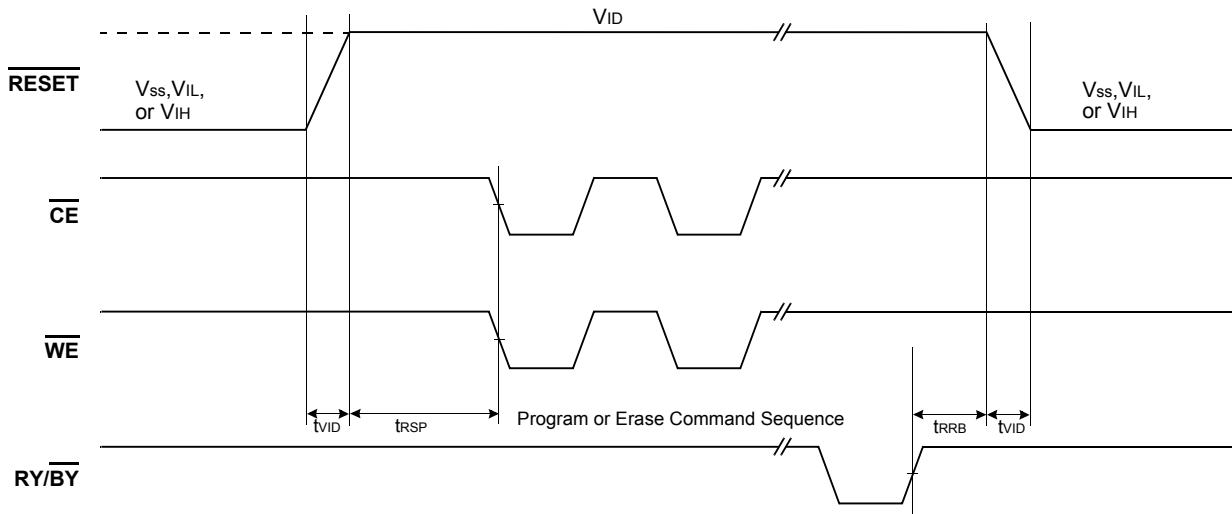

SWITCHING WAVEFORMS

Unlock Bypass Program Operations(Accelerated Program)

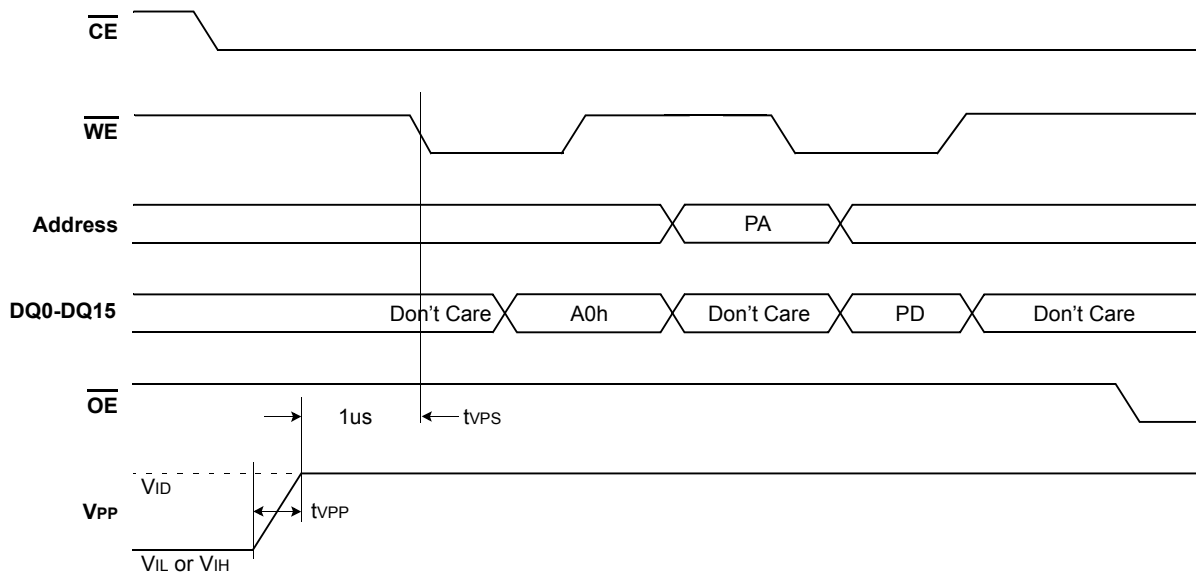

Unlock Bypass Block Erase Operations

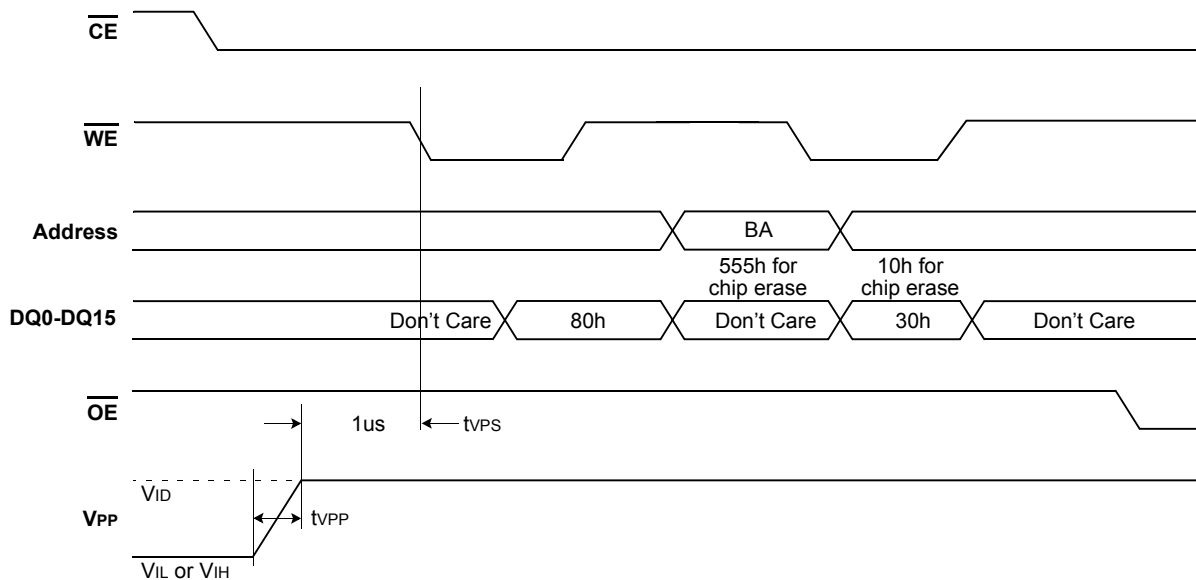

Notes:

- 1. V_{PP} can be left high for subsequent programming pulses.
- 2. Use setup and hold times from conventional program operations.
- 3. Unlock Bypass Program/Erase commands can be used when the V_{ID} is applied to V_{PP} .

Figure 22. Unlock Bypass Operation Timings

SWITCHING WAVEFORMS

Quad word Accelerated Program

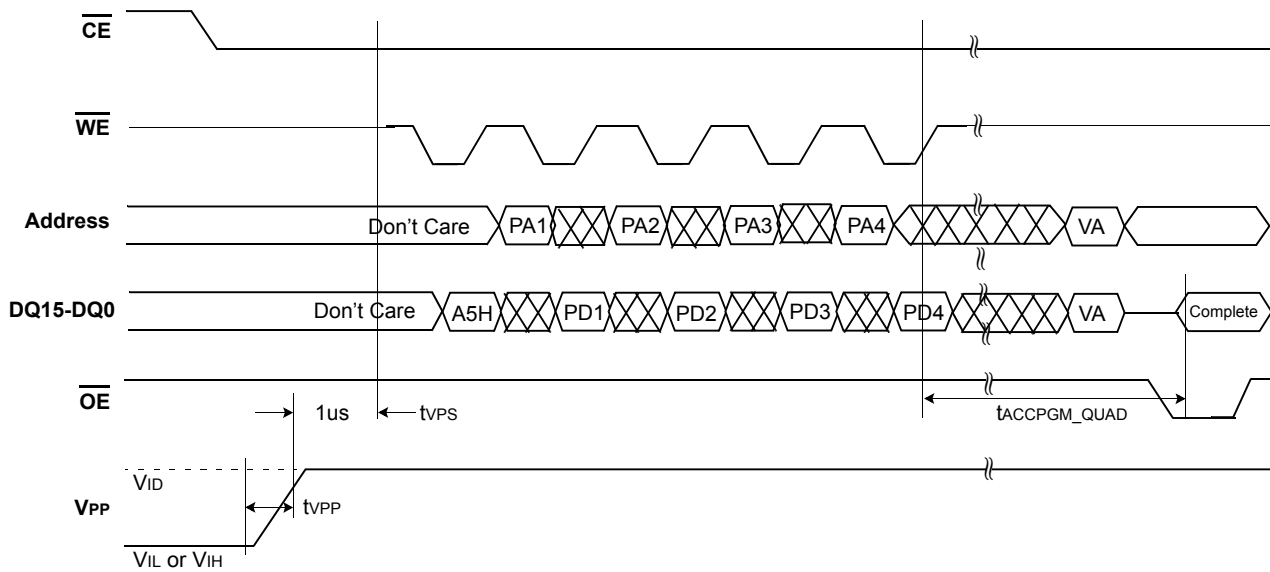

Notes:

- 1. V_{PP} can be left high for subsequent programming pulses.
- 2. Use setup and hold times from conventional program operations.
- 3. Quad word Accelerate program commands can be used when the V_{ID} is applied to V_{pp} .

Figure 23. Quad word Accelerated Program Operation Timings

K8P3215UQB

FLASH MEMORY

Table 13. Block Architecture (K8P3215UQB)

Bank	Block	Block Size	(x16) Address Range
Bank 3	BA77	4 Kwords	1FF000h-1FFFFFh
	BA76	4 Kwords	1FE000h-1FEFFFh
	BA75	4 Kwords	1FD000h-1DFFFFh
	BA74	4 Kwords	1FC000h-1CFFFFh
	BA73	4 Kwords	1FB000h-1BFFFFh
	BA72	4 Kwords	1FA000h-1FAFFFh
	BA71	4 Kwords	1F9000h-1F9FFFh
	BA70	4 Kwords	1F8000h-1F8FFFh
	BA69	32 Kwords	1F0000h-1F7FFFh
	BA68	32 Kwords	1E8000h-1EFFFFh
	BA67	32 Kwords	1E0000h-1E7FFFh
	BA66	32 Kwords	1D8000h-1DFFFFh
	BA65	32 Kwords	1D0000h-1D7FFFh
	BA64	32 Kwords	1C8000h-1CFFFFh
	BA63	32 Kwords	1C0000h-1C7FFFh
Bank 2	BA62	32 Kwords	1B8000h-1BFFFFh
	BA61	32 Kwords	1B0000h-1B7FFFh
	BA60	32 Kwords	1A8000h-1AFFFFh
	BA59	32 Kwords	1A0000h-1A7FFFh
	BA58	32 Kwords	198000h-19FFFFh
	BA57	32 Kwords	190000h-197FFFh
	BA56	32 Kwords	188000h-18FFFFh
	BA55	32 Kwords	180000h-187FFFh
	BA54	32 Kwords	178000h-17FFFFh
	BA53	32 Kwords	10000h-177FFFh
	BA52	32 Kwords	168000h-16FFFFh
	BA51	32 Kwords	160000h-167FFFh
	BA50	32 Kwords	158000h-15FFFFh
	BA49	32 Kwords	150000h-157FFFh
	BA48	32 Kwords	148000h-14FFFFh
	BA47	32 Kwords	140000h-147FFFh
	BA46	32 Kwords	138000h-13FFFFh
	BA45	32 Kwords	130000h-137FFFh
	BA44	32 Kwords	128000h-12FFFFh
	BA43	32 Kwords	120000h-127FFFh
	BA42	32 Kwords	118000h-11FFFFh
BA41	32 Kwords	110000h-117FFFh	
BA40	32 Kwords	108000h-10FFFFh	
BA39	32 Kwords	100000h-107FFFh	

K8P3215UQB

FLASH MEMORY

Table 13. Block Architecture (K8P3215UQB)

Bank	Block	Block Size	(x16) Address Range
Bank 1	BA38	32 Kwords	0F8000h-0FFFFFFh
	BA37	32 Kwords	0F0000h-07FFFFh
	BA36	32 Kwords	0E8000h-0EFFFFh
	BA35	32 Kwords	0E0000h-0E7FFFh
	BA34	32 Kwords	0D8000h-0DFFFFh
	BA33	32 Kwords	0D0000h-0D7FFFh
	BA32	32 Kwords	0C8000h-0CFFFFh
	BA31	32 Kwords	0C0000h-0C7FFFh
	BA30	32 Kwords	0B8000h-0BFFFFh
	BA29	32 Kwords	0B0000h-0B7FFFh
	BA28	32 Kwords	0A8000h-0AFFFFh
	BA27	32 Kwords	0A0000h-0A7FFFh
	BA26	32 Kwords	098000h-09FFFFh
	BA25	32 Kwords	090000h-097FFFh
	BA24	32 Kwords	088000h-08FFFFh
	BA23	32 Kwords	080000h-087FFFh
	BA22	32 Kwords	078000h-07FFFFh
	BA21	32 Kwords	070000h-077FFFh
	BA20	32 Kwords	068000h-06FFFFh
	Bank0	BA19	32 Kwords
BA18		32 Kwords	058000h-05FFFFh
BA17		32 Kwords	050000h-057FFFh
BA16		32 Kwords	048000h-04FFFFh
BA15		32 Kwords	040000h-047FFFh
BA14		32 Kwords	038000h-03FFFFh
BA13		32 Kwords	030000h-037FFFh
BA12		32 Kwords	028000h-02FFFFh
BA11		32 Kwords	020000h-027FFFh
BA10		32 Kwords	018000h-01FFFFh
BA9		32 Kwords	010000h-017FFFh
BA8		32 Kwords	008000h-00FFFFh
BA7		4 Kwords	007000h-007FFFh
BA6		4 Kwords	006000h-006FFFh
BA5		4 Kwords	005000h-005FFFh
BA4		4 Kwords	004000h-004FFFh
BA3	4 Kwords	003000h-003FFFh	
BA2	4 Kwords	002000h-002FFFh	
BA1	4 Kwords	001000h-001FFFh	
BA0	4 Kwords	000000h-000FFFh	

K8P3215UQB

FLASH MEMORY

PACKAGE DIMENSIONS

48-PIN LEAD PLASTIC THIN SMALL OUT-LINE PACKAGE TYPE(I)

