

FEATURES

- Adjustable Push Button On/Off Timers
- Low Supply Current: 6 μ A
- Wide Operating Voltage Range: 2.7V to 26V
- EN Output (LTC2950-1) Allows DC/DC Converter Control
- $\overline{\text{EN}}$ Output (LTC2950-2) Allows Circuit Breaker Control
- Simple Interface Allows Graceful μ P Shut Down
- High Input Voltage PB Pin with Internal Pull Up Resistor
- ± 10 kV ESD HBM on $\overline{\text{PB}}$ Input
- Accurate 0.6V Threshold on $\overline{\text{KILL}}$ Comparator Input
- 8-Pin 3mm \times 2mm DFN and ThinSOT™ Packages

APPLICATIONS

- Portable Instrumentation Meters
- Blade Servers
- Portable Customer Service PDA
- Desktop and Notebook Computers

DESCRIPTION

The LTC[®]2950 is a micropower, wide input voltage range, push button ON/OFF controller. The part contains a push button input with independently programmable ON and OFF debounce times that control the toggling of an open drain enable output. The part also contains a simple microprocessor interface to allow for proper system housekeeping prior to power down. Under system fault conditions, an internal $\overline{\text{KILL}}$ timer ensures proper power down.

The LTC2950 operates over a wide 2.7V to 26V input voltage range to accommodate a wide variety of input power supplies. Very low quiescent current (6 μ A typical) makes the LTC2950 ideally suited for battery powered applications. Two versions of the part are available to accommodate either positive or negative enable polarities. The parts are available in either 8-lead 3mm \times 2mm DFN or ThinSOT packages.

LT, LTC and LTM are registered trademarks of Linear Technology Corporation. ThinSOT is a trademark of Linear Technology Corporation. All other trademarks are the property of their respective owners.

TYPICAL APPLICATION

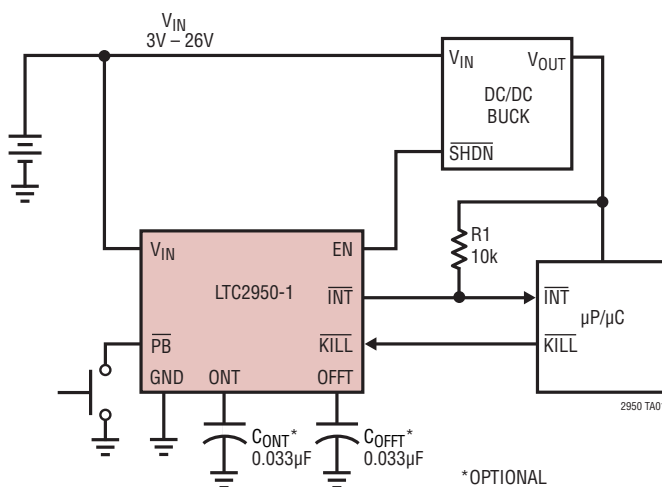

Turn On Debounce

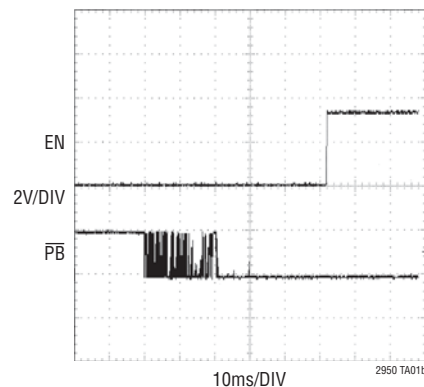

LTC2950-1/LTC2950-2

ABSOLUTE MAXIMUM RATINGS (Note 1)

Supply Voltage (V_{IN})	–0.3V to 33V	Operating Temperature Range	
Input Voltages		LTC2950-C1	0°C to 70°C
\overline{PB}	–6V to 33V	LTC2950-C2	0°C to 70°C
ONT	–0.3V to 2.7V	LTC2950-I1	–40°C to 85°C
OFFT	–0.3V to 2.7V	LTC2950-I2	–40°C to 85°C
\overline{KILL}	–0.3V to 7V	Storage Temperature Range	
Output Voltages		DFN Package	–65°C to 125°C
\overline{INT}	–0.3V to 10V	TSOT-23	–65°C to 150°C
$\overline{EN/EN}$	–0.3V to 10V	Lead Temperature (Soldering, 10 sec)	300°C

PIN CONFIGURATION

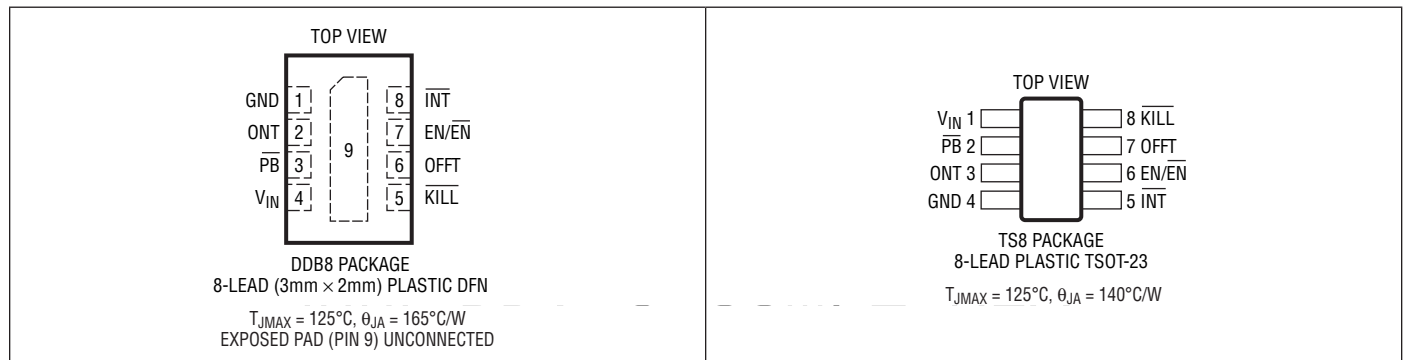

ORDER INFORMATION

Lead Free Finish

TAPE AND REEL (MINI)	TAPE AND REEL	PART MARKING*	PACKAGE DESCRIPTION	TEMPERATURE RANGE
LTC2950CDDB-1#TRMPBF	LTC2950CDDB-1#TRPBF	LBKP	8-Lead Plastic DFN	0°C to 70°C
LTC2950CDDB-2#TRMPBF	LTC2950CDDB-2#TRPBF	LBNG	8-Lead Plastic DFN	0°C to 70°C
LTC2951CDDB-1#TRMPBF	LTC2951CDDB-1#TRPBF	LBKP	8-Lead Plastic DFN	–40°C to 85°C
LTC2951CDDB-2#TRMPBF	LTC2951CDDB-2#TRPBF	LBNG	8-Lead Plastic DFN	–40°C to 85°C
LTC2950CTS8-1#TRMPBF	LTC2950CTS8-1#TRPBF	LTBKN	8-Lead Plastic TSOT-23	0°C to 70°C
LTC2950CTS8-2#TRMPBF	LTC2950CTS8-2#TRPBF	LTBNF	8-Lead Plastic TSOT-23	0°C to 70°C
LTC2950ITS8-1#TRMPBF	LTC2950ITS8-1#TRPBF	LTBKN	8-Lead Plastic TSOT-23	–40°C to 85°C
LTC2950ITS8-2#TRMPBF	LTC2950ITS8-2#TRPBF	LTBNF	8-Lead Plastic TSOT-23	–40°C to 85°C

TRM = 500 pieces. *Temperature grades are identified by a label on the shipping container.

Consult LTC Marketing for parts specified with wider operating temperature ranges.

Consult LTC Marketing for information on lead based finish parts.

For more information on lead free part marking, go to: <http://www.linear.com/leadfree/>

For more information on tape and reel specifications, go to: <http://www.linear.com/tapeandreeel/>

ELECTRICAL CHARACTERISTICS

The ● denotes the specifications which apply over the full operating temperature range, otherwise specifications are at $T_A = 25^\circ\text{C}$. $V_{IN} = 2.7\text{V}$ to 26.4V , unless otherwise noted. (Note 2)

SYMBOL	PARAMETER	CONDITIONS		MIN	TYP	MAX	UNITS
V_{IN}	Supply Voltage Range	Steady State Operation	●	2.7		26.4	V
I_{IN}	V_{IN} Supply Current	System Power On, $V_{IN} = 2.7\text{V}$ to 24V	●		6	12	μA
V_{UVL}	V_{IN} Undervoltage Lockout	V_{IN} Falling	●	2.2	2.3	2.4	V
$V_{UVL(HYST)}$	V_{IN} Undervoltage Lockout Hysteresis			50	300	600	mV
Push Button Pin ($\overline{\text{PB}}$)							
$V_{\overline{\text{PB}}(\text{MIN, MAX})}$	$\overline{\text{PB}}$ Voltage Range	Single-Ended	●	-1		26.4	V
$I_{\overline{\text{PB}}}$	$\overline{\text{PB}}$ Input Current	$2.5\text{V} < V_{\overline{\text{PB}}} < 26.4\text{V}$ $V_{\overline{\text{PB}}} = 1\text{V}$ $V_{\overline{\text{PB}}} = 0.6\text{V}$	● ● ●	-1 -3	-6 -9	± 1 -12 -15	μA μA μA
$V_{\overline{\text{PB}}(\text{VTH})}$	$\overline{\text{PB}}$ Input Threshold	$\overline{\text{PB}}$ Falling	●	0.6	0.8	1	V
$V_{\overline{\text{PB}}(\text{VOC})}$	$\overline{\text{PB}}$ Open Circuit Voltage	$I_{\overline{\text{PB}}} = -1\mu\text{A}$		1	1.6	2	V
Debounce Timing Pins (ONT, OFFT)							
$I_{\text{ONT, OFFT(PU)}}$	ONT/OFFT Pull Up Current	$V_{\text{ONT, OFFT}} = 0\text{V}$	●	-2.4	-3	-3.6	μA
$I_{\text{ONT, OFFT(PD)}}$	ONT/OFFT Pull Down Current	$V_{\text{ONT, OFFT}} = 1.3\text{V}$	●	2.4	3	3.6	μA
$t_{\text{DB, On}}$	Internal Turn On Debounce Time	ONT Pin Float, $\overline{\text{PB}}$ Falling \rightarrow Enable Asserted	●	26	32	41	ms
t_{ONT}	Additional Adjustable Turn On Time	$C_{\text{ONT}} = 1500\text{pF}$	●	9	11.5	13.5	ms
$t_{\text{DB, Off}}$	Internal Turn Off Debounce Time	OFFT Pin Float, $\overline{\text{PB}}$ Falling \rightarrow $\overline{\text{INT}}$ Falling	●	26	32	41	ms
t_{OFFT}	Additional Adjustable Turn Off Time	$C_{\text{OFFT}} = 1500\text{pF}$	●	9	11.5	13.5	ms
μP Handshake Pins ($\overline{\text{INT}}$, $\overline{\text{KILL}}$)							
$I_{\overline{\text{INT}}(\text{LKG})}$	$\overline{\text{INT}}$ Leakage Current	$V_{\overline{\text{INT}}} = 3\text{V}$	●			± 1	μA
$V_{\overline{\text{INT}}(\text{VOL})}$	$\overline{\text{INT}}$ Output Voltage Low	$I_{\overline{\text{INT}}} = 3\text{mA}$	●		0.11	0.4	V
$V_{\overline{\text{KILL}}(\text{TH})}$	$\overline{\text{KILL}}$ Input Threshold Voltage	$\overline{\text{KILL}}$ Falling	●	0.57	0.6	0.63	V
$V_{\overline{\text{KILL}}(\text{HYST})}$	$\overline{\text{KILL}}$ Input Threshold Hysteresis			10	30	50	mV
$I_{\overline{\text{KILL}}(\text{LKG})}$	$\overline{\text{KILL}}$ Leakage Current	$V_{\overline{\text{KILL}}} = 0.6\text{V}$				± 0.1	μA
$t_{\overline{\text{KILL}}(\text{PW})}$	$\overline{\text{KILL}}$ Minimum Pulse Width		●	30			μs
$t_{\overline{\text{KILL}}(\text{PD})}$	$\overline{\text{KILL}}$ Propagation Delay	$\overline{\text{KILL}}$ Falling \rightarrow Enable Released	●			30	μs
$t_{\overline{\text{KILL, On Blank}}}$	$\overline{\text{KILL}}$ Turn On Blanking (Note 3)	$\overline{\text{KILL}} = \text{Low}$, Enable Asserted \rightarrow Enable Released	●	400	512	650	ms
$t_{\overline{\text{KILL, Off Delay}}}$	$\overline{\text{KILL}}$ Turn Off Delay (Note 4)	$\overline{\text{KILL}} = \text{High}$, $\overline{\text{INT}}$ Asserted \rightarrow Enable Released	●	800	1024	1300	ms
$t_{\text{EN}/\overline{\text{EN}}, \text{Lock Out}}$	EN/ $\overline{\text{EN}}$ Lock Out Time (Note 5)	Enable Released \rightarrow Enable Asserted	●	200	256	325	ms
$I_{\text{EN}/\overline{\text{EN}}(\text{LKG})}$	EN/ $\overline{\text{EN}}$ Leakage Current	$V_{\text{EN}/\overline{\text{EN}}} = 1\text{V}$, Sink Current Off	●			± 0.1	μA
$V_{\text{EN}/\overline{\text{EN}}(\text{VOL})}$	EN/ $\overline{\text{EN}}$ Voltage Output Low	$I_{\text{EN}/\overline{\text{EN}}} = 3\text{mA}$	●		0.11	0.4	V

Note 1: Stresses beyond those listed under Absolute Maximum Ratings may cause permanent damage to the device. Exposure to any Absolute Maximum Rating condition for extended periods may affect device reliability and lifetime.

Note 2: All currents into pins are positive; all voltages are referenced to GND unless otherwise noted.

Note 3: The $\overline{\text{KILL}}$ turn on blanking timer period is the waiting period immediately after the enable output is asserted. This blanking time allows sufficient time for the DC/DC converter and the μP to perform power up tasks. The $\overline{\text{KILL}}$ and $\overline{\text{PB}}$ inputs are ignored during this period. If $\overline{\text{KILL}}$ remains low at the end of this time period, the enable output is released, thus turning off system power. This time delay does not include $t_{\text{DB, ON}}$ or t_{ONT} .

Note 4: The $\overline{\text{KILL}}$ turn off delay is the maximum delay from the initiation of a shutdown sequence ($\overline{\text{INT}}$ falling), to the release of the enable output. If the $\overline{\text{KILL}}$ input switches low at any time during this period, enable is released, thus turning off system power. This time is internally fixed at 1024ms. This time delay does not include $t_{\text{DB, OFF}}$ or t_{OFFT} .

Note 5: The enable lock out time is designed to allow an application to properly power down such that the next power up sequence starts from a consistent powered down configuration. $\overline{\text{PB}}$ is ignored during this lock out time. This time delay does not include $t_{\text{DB, ON}}$ or t_{ONT} .

TYPICAL PERFORMANCE CHARACTERISTICS

Supply Current vs Temperature

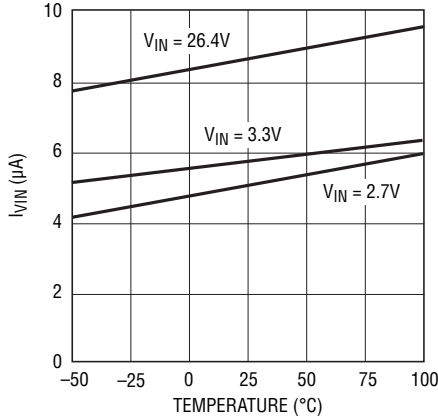

2950 G01

Supply Current vs Supply Voltage

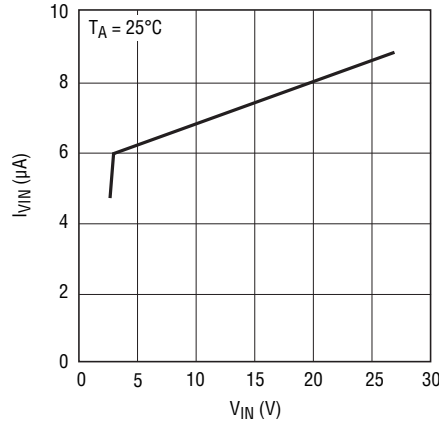

2950 G02

Internal Default Turn On Debounce Time ($t_{DB, ON}$) vs V_{IN}

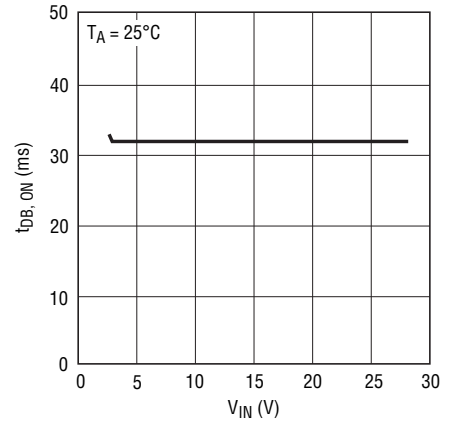

2950 G03

Turn On Debounce Time ($t_{DB, ON} + t_{ONT}$) vs ONT External Capacitor

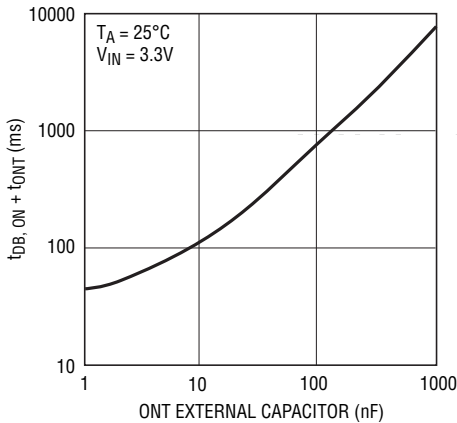

2950 G04

ONT Pull-Down Current vs Temperature

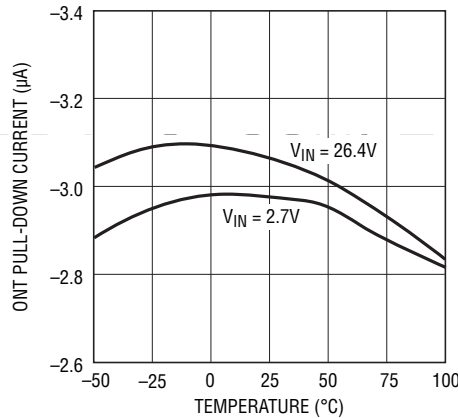

2950 G05

Internal Default Turn Off Debounce Time ($t_{DB, OFF}$) vs V_{IN}

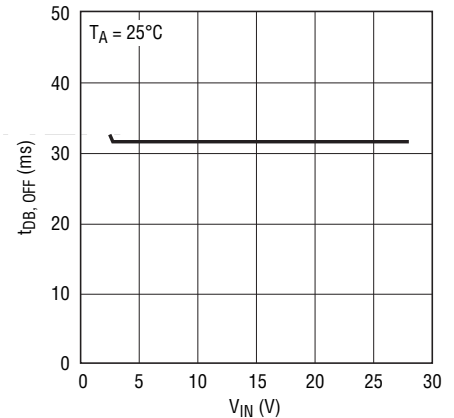

2950 G06

Turn Off Debounce Time ($t_{DB, OFF} + t_{OFFT}$) vs OFFT External Capacitor

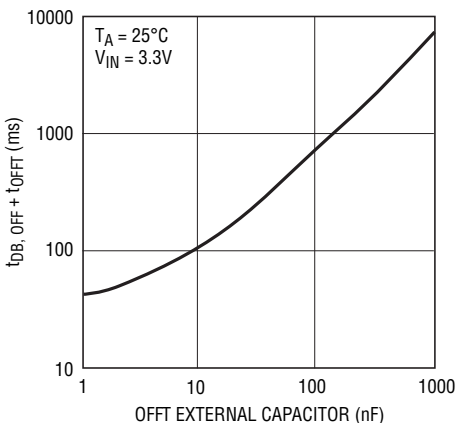

2950 G07

OFFT Pull-Down Current vs Temperature

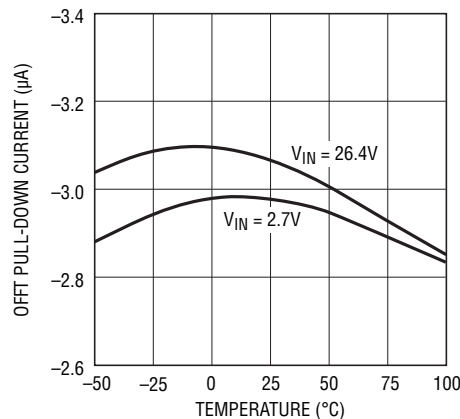

2950 G08

PB Current vs PB Voltage

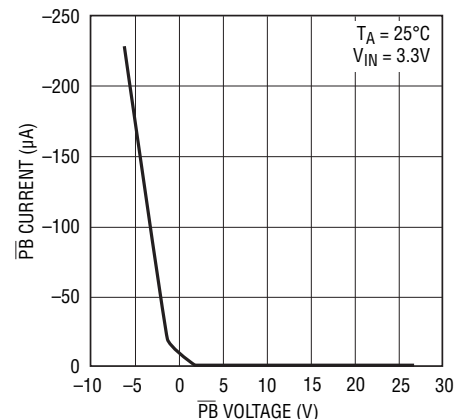

2950 G09

295012fb

TYPICAL PERFORMANCE CHARACTERISTICS

PB Voltage vs External PB Resistance to Ground

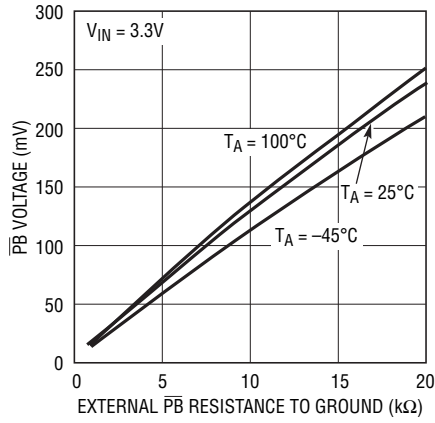

2950 G10

EN/EN V_{OL} vs Current Load

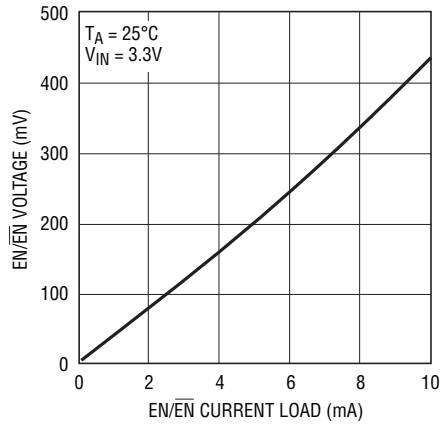

2950 G11

EN (LTC2950-1) Voltage vs V_{IN}

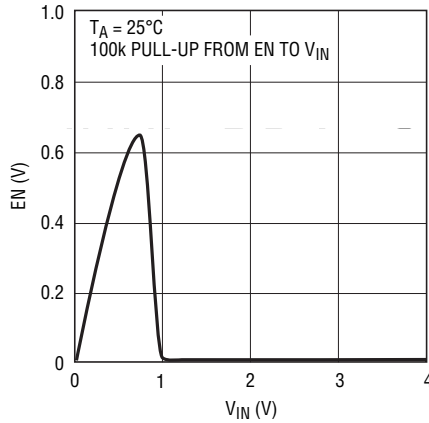

2950 G12

EN (LTC2950-2) Voltage vs V_{IN}

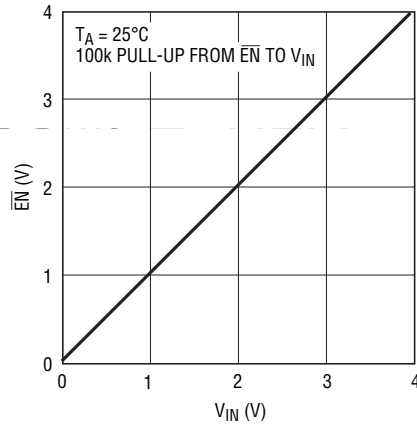

2950 G13

PIN FUNCTIONS (TSOT-23/DFN)

V_{IN} (Pin 1/Pin 4): Power Supply Input: 2.7V to 26.4V.

\overline{PB} (Pin 2/Pin 3): Push Button Input. Connecting \overline{PB} to ground through a momentary switch provides on/off control via the EN/ \overline{EN} pin. An internal 100k pull-up resistor connects to an internal 1.9V bias voltage. The rugged \overline{PB} input can be pulled up to 26.4V externally without consuming extra current.

ONT (Pin 3/Pin 2): Additional Adjustable Turn On Time Input. Placing an external capacitor to ground determines the additional time (beyond the internal default 32ms) the \overline{PB} pin must be held low before the enable output is asserted. Floating this pin results in a default turn on debounce time of 32ms.

GND (Pin 4/Pin 1): Device Ground.

\overline{INT} (Pin 5/Pin 8): Open Drain Interrupt Output. After a push button turn-off event is detected, the LTC2950 interrupts the system (μP) by bringing the \overline{INT} pin low. Once the system finishes its power down and housekeeping tasks, it sets \overline{KILL} low, which in turn releases the enable output. If at the end of the power down timer (1024ms) \overline{KILL} is still high, the enable output is released immediately. \overline{INT} may optionally be tied to \overline{KILL} to release the enable output immediately after the turn-off event has been detected ($\overline{INT} = \text{low}$).

EN (LTC2950-1, Pin 6/Pin 7): Open Drain Enable Output. This pin is intended to enable system power. EN is asserted high after a valid \overline{PB} turn on event. EN is released low if: a) \overline{KILL} is not driven high (by μP) within 512ms of the initial valid \overline{PB} power turn-on event, b) \overline{KILL} is driven low during normal operation, c) a second valid \overline{PB} event (power turn-off) is detected. The operating range for this pin is 0V to 10V.

\overline{EN} (LTC2950-2, Pin 6/Pin 7): Open Drain Enable Output. This pin is intended to enable system power. \overline{EN} is asserted low after a valid \overline{PB} turn-on event. \overline{EN} releases high if: a) \overline{KILL} is not driven high (by μP) within 512ms of the initial valid \overline{PB} power turn-on event, b) \overline{KILL} is driven low during normal operation, c) a second valid \overline{PB} event (power turn-off) is detected. The operating range of this pin is 0V to 10V.

OFFT (Pin 7/Pin 6): Additional Adjustable Turn Off Time Input. A capacitor to ground determines the additional time (beyond the internal default 32ms) that the \overline{PB} pin must be held low before initiating a power down sequence (\overline{INT} falling). Floating this pin results in a default turn off time of 32ms.

\overline{KILL} (Pin 8/Pin 5): \overline{KILL} Input. Forcing \overline{KILL} low releases the enable output. During system turn on, this pin is blanked by a 512ms internal timer to allow the system to pull \overline{KILL} high. This pin has an accurate 0.6V threshold and can be used as a voltage monitor input.

Exposed Pad (Pin 9): Exposed Pad may be left open or connected to device ground.

BLOCK DIAGRAMS

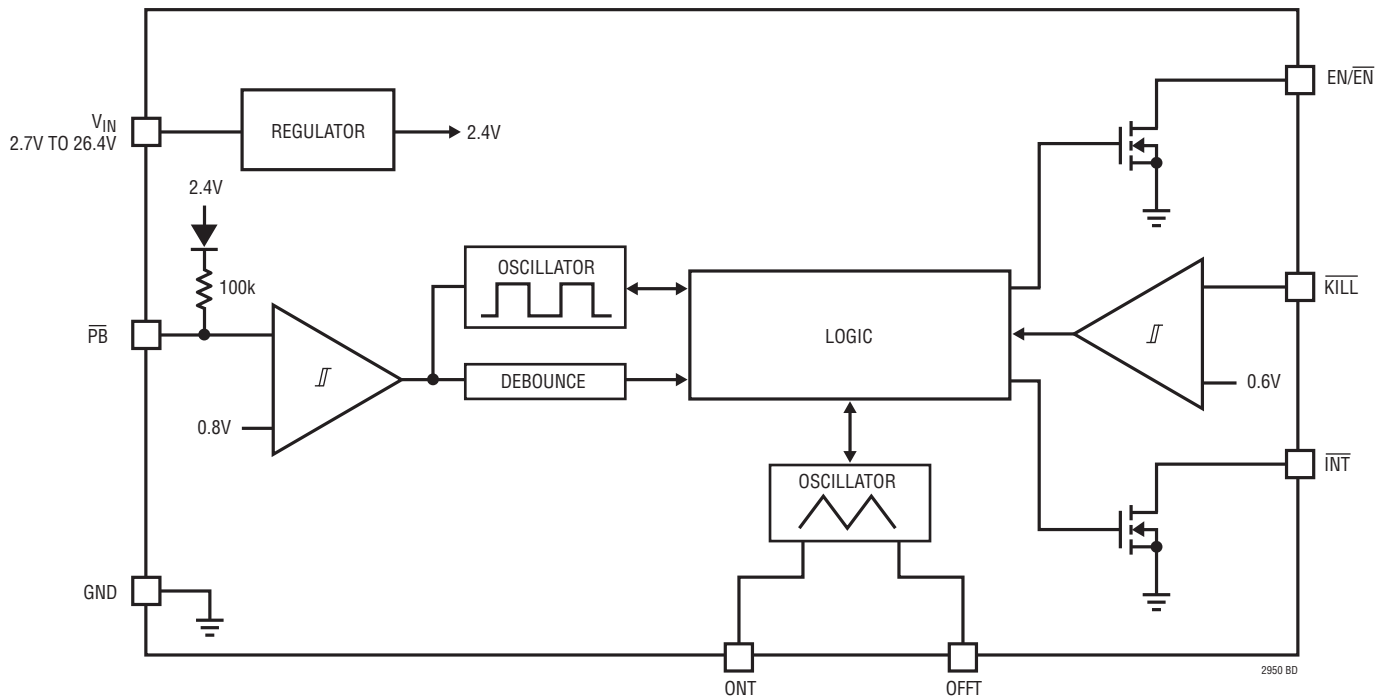

TIMING DIAGRAMS

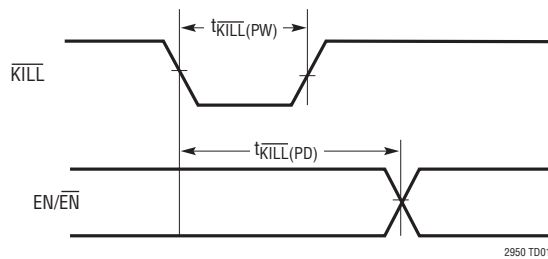

TIMING DIAGRAMS

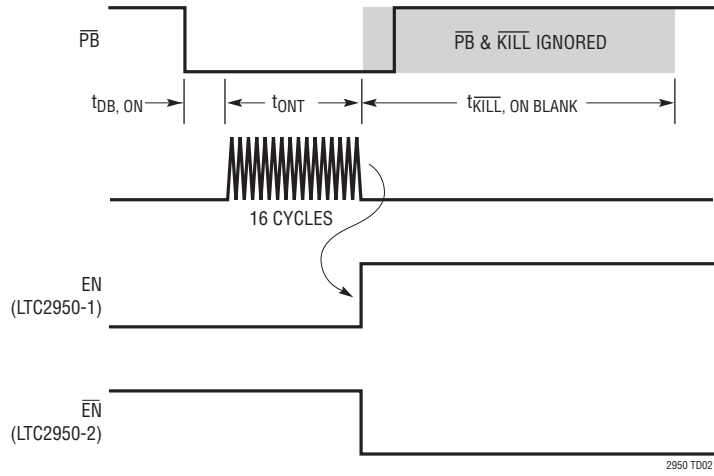

Power On Timing

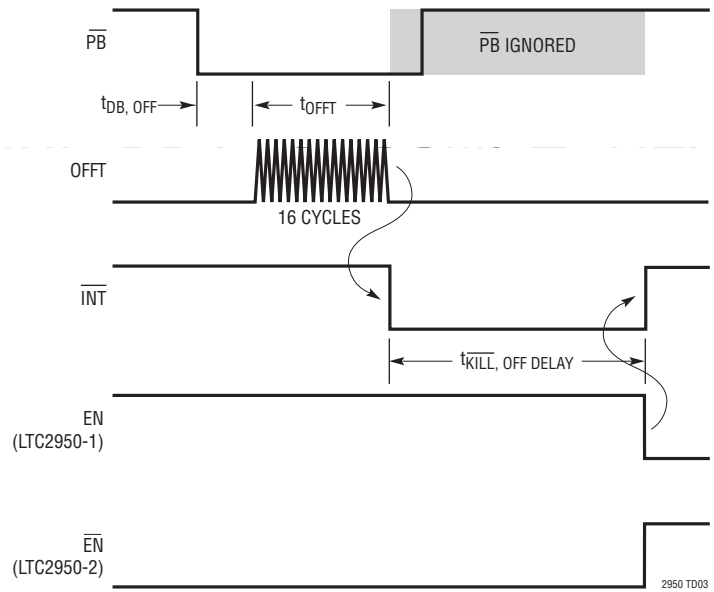

Power Off Timing, $\overline{KILL} > 0.6V$

APPLICATIONS INFORMATION

Description

The LTC2950 is a low power (6 μ A), wide input voltage range (2.7V to 26.4V), push button on/off controller that can interface to a μ P and a power supply. The turn-on and turn-off debounce times are extendable using optional external capacitors. A simple interface ($\overline{\text{INT}}$ output, $\overline{\text{KILL}}$ input) allows a system to power on and power off in a controlled manner.

Turn On

When power is first applied to the LTC2950, the part initializes the output pins. Any DC/DC converters connected to the EN/ $\overline{\text{EN}}$ pin will therefore be held off. To assert the enable output, $\overline{\text{PB}}$ must be held low for a minimum of 32ms ($t_{\text{DB, ON}}$). The LTC2950 provides additional turn on debounce time via an optional capacitor connected to the ONT pin (t_{ONT}). The following equation describes the additional time that $\overline{\text{PB}}$ must be held low before asserting the enable output. C_{ONT} is the ONT external capacitor:

$$C_{\text{ONT}} = 1.56\text{E-}4 \text{ } [\mu\text{F/ms}] \cdot (t_{\text{ONT}} - 1\text{ms})$$

Once the enable output is asserted, any DC/DC converters connected to this pin are turned on. The $\overline{\text{KILL}}$ input from the μ P is ignored during a succeeding 512ms blanking time ($t_{\text{KILL, ON BLANK}}$). This blanking time represents the maximum time required to power up the DC/DC converter and the μ P. If $\overline{\text{KILL}}$ is not brought high during this 512ms time window, the enable output is released. The assumption is that 512ms is sufficient time for the system to power up.

Turn Off

To initiate a power off sequence, $\overline{\text{PB}}$ must be held low for a minimum of 32ms ($t_{\text{DB, OFF}}$). Additional turn off debounce time may be added via an optional capacitor connected to the OFFT pin (t_{OFFT}). The following equation describes the additional time that $\overline{\text{PB}}$ must be held low to initiate a power off sequence. C_{OFFT} is the OFFT external capacitor:

$$C_{\text{OFFT}} = 1.56\text{E-}4 \text{ } [\mu\text{F/ms}] \cdot (t_{\text{OFFT}} - 1\text{ms})$$

Once $\overline{\text{PB}}$ has been validly pressed, $\overline{\text{INT}}$ is switched low. This alerts the μ P to perform its power down and housekeeping tasks. The power down time given to the μ P is 1024ms.

Note that the $\overline{\text{KILL}}$ input can be pulled low (thereby releasing the enable output) at any time after $t_{\text{KILL, ON BLANK}}$ period.

Simplified Power On/Off Sequence

Figure 1 shows a simplified LTC2950-1 power on and power off sequence. A high to low transition on $\overline{\text{PB}}$ (t_1) initiates the power on sequence. This diagram does not show any bounce on $\overline{\text{PB}}$. In order to assert the enable output, the $\overline{\text{PB}}$ pin must stay low continuously ($\overline{\text{PB}}$ high resets timers) for a time controlled by the default 32ms and the external ONT capacitor ($t_2 - t_1$). Once EN goes high (t_2), an internal 512ms blanking timer is started. This blanking timer is designed to give sufficient time for the DC/DC converter to reach its final voltage, and to allow the μ P enough time to perform power on tasks.

The $\overline{\text{KILL}}$ pin must be pulled high within 512ms of the EN pin going high. Failure to do so results in the EN pin going low 512ms after it went high. (EN = low, see Figure 2). Note that the LTC2950 does not sample $\overline{\text{KILL}}$ and $\overline{\text{PB}}$ until after the 512ms internal timer has expired. The reason $\overline{\text{PB}}$ is ignored is to ensure that the system is not forced off while powering on. Once the 512ms timer expires (t_4), the release of the $\overline{\text{PB}}$ pin is then debounced with an internal 32ms timer. The system has now properly powered on and the LTC2950 monitors $\overline{\text{PB}}$ and $\overline{\text{KILL}}$ (for a turnoff command) while consuming only 6 μ A of supply current.

A high to low transition on $\overline{\text{PB}}$ (t_5) initiates the power off sequence. $\overline{\text{PB}}$ must stay low continuously ($\overline{\text{PB}}$ high resets debounce timer) for a period controlled by the default 32ms and the external OFFT capacitor ($t_6 - t_5$). At the completion of the OFFT timing (t_6), an interrupt ($\overline{\text{INT}}$) is set, signifying that EN will be switched low in 1024ms. Once a system has finished performing its power down operations, it can set $\overline{\text{KILL}}$ low (t_7) and thus immediately set EN low, terminating the internal 1024ms timer. The release of the $\overline{\text{PB}}$ pin is then debounced with an internal 32ms timer.

The system is now in its reset state: where the LTC2950 is in low power mode (6 μ A). $\overline{\text{PB}}$ is monitored for a high to low transition.

APPLICATIONS INFORMATION

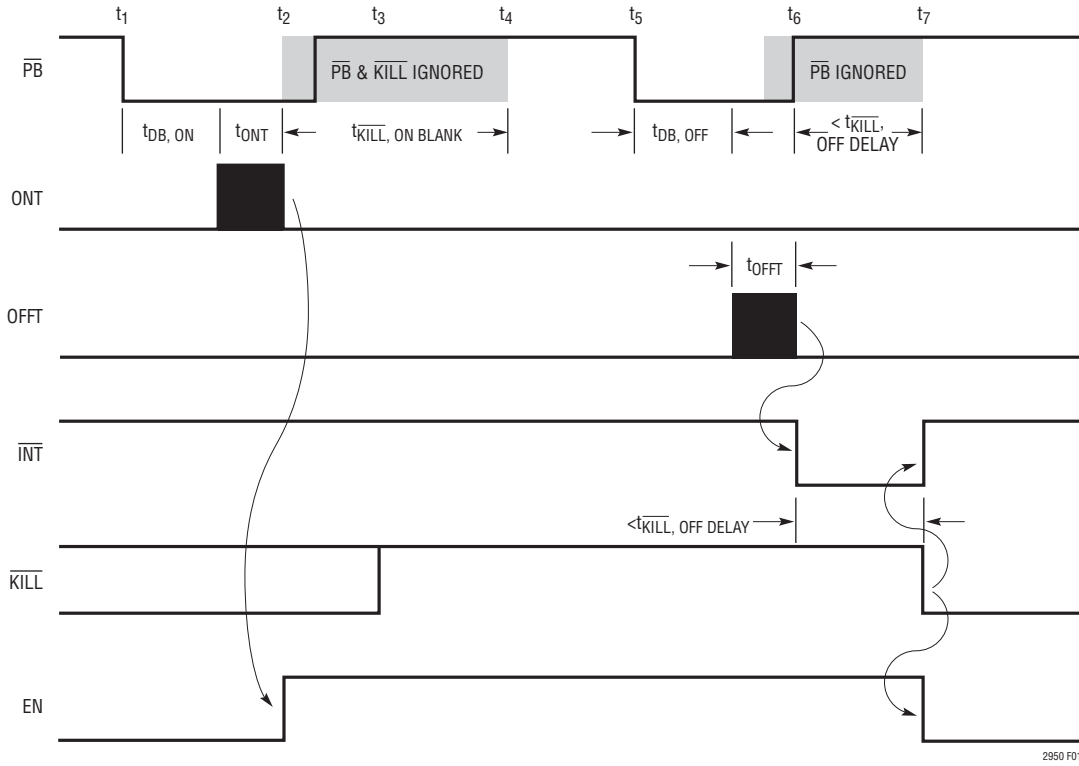

Figure 1. Simplified Power On/Off Sequence for LTC2950-1

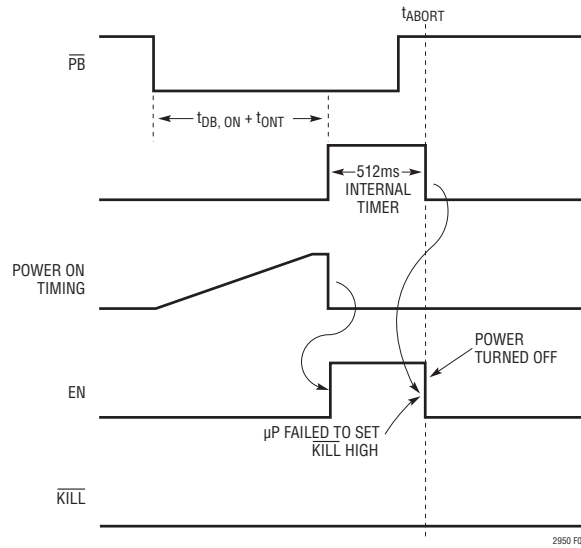

Figure 2. Aborted Power On Sequence for LTC2950-1

APPLICATIONS INFORMATION

Aborted Power On Sequence

The power on sequence is aborted when the $\overline{\text{KILL}}$ remains low after the end of the 512ms blanking time. Figure 2 is a simplified version of an aborted power on sequence. At time t_{ABORT} , since $\overline{\text{KILL}}$ is still low, EN pulls low (thus turning off the DC/DC converter).

μP Turns Off Power During Normal Operation

Once the system has powered on and is operating normally, the μP can turn off power by setting $\overline{\text{KILL}}$ low, as shown in Figure 3. At time t_{KILL} , $\overline{\text{KILL}}$ is set low by the μP . This immediately pulls EN low, thus turning off the DC/DC converter.

DC/DC Turn Off Blanking

When the DC/DC converter is turned off, it can take a significant amount of time for its output to decay to ground. It is desirable to wait until the output of the DC/DC converter is near ground before allowing the user (via $\overline{\text{PB}}$) to restart the converter. This condition guarantees that the μP is always powered down completely before it is restarted.

Figure 4 shows the μP turning power off. After a low on $\overline{\text{KILL}}$ releases enable, the internal 256ms timer ignores the $\overline{\text{PB}}$ pin. This is shown as $t_{\text{EN}/\overline{\text{EN}}}$, LOCKOUT in Figure 4.

LTC2950-1, LTC2950-2 VERSIONS

The LTC2950-1 (high true EN) and LTC2950-2 (low true $\overline{\text{EN}}$) differ only by the polarity of the EN/ $\overline{\text{EN}}$ pin. Both versions allow the user to extend the amount of time that the $\overline{\text{PB}}$ must be held low in order to begin a valid power on/off sequence. An external capacitor placed on the ONT pin adds additional time to the turn on time. An external capacitor placed on the OFFT pin adds additional time to the turn off time. If no capacitor is placed on the ONT (OFFT) pin, then the turn on (off) duration is given by an internally fixed 32ms timer.

The LTC2950 fixes the $\overline{\text{KILL}}$ turn off delay time ($t_{\text{KILL, OFF DELAY}}$) at 1024ms. This means that the EN/ $\overline{\text{EN}}$ pin will be switched low/high a maximum of 1024ms after initiating a valid turn off sequence. Note that in a typical application, a μP or μC would set $\overline{\text{KILL}}$ low prior to the 1024ms timer period (t_7 in Figure 1).

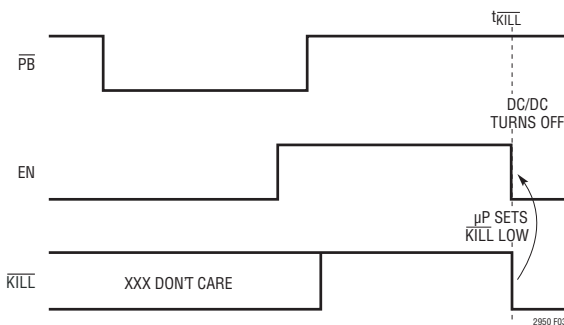

Figure 3. μP Turns Off Power (LTC2950-1)

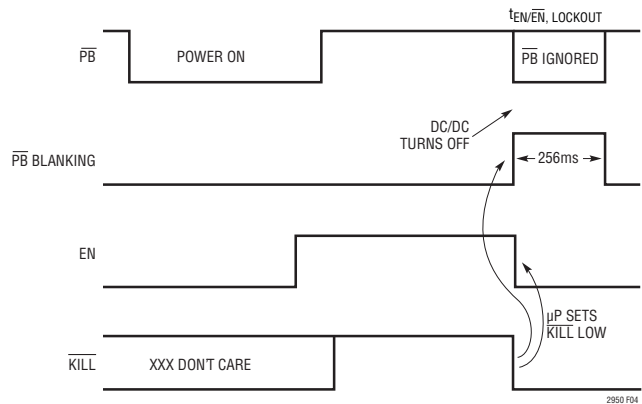

Figure 4. DC/DC Turn Off Blanking (LTC2950-1)

APPLICATIONS INFORMATION

The following equations describe the turn on and turn off times. C_{ONT} and C_{OFFT} are the external programming capacitors:

$$t_{BD,ON} + t_{ONT} = 32ms + 1ms + (6.7 \times 10^6) \cdot C_{ONT}$$

$$t_{BD,OFF} + t_{OFFT} = 32ms + 1ms + (6.7 \times 10^6) \cdot C_{OFFT}$$

High Voltage Pins

The V_{IN} and \overline{PB} pins can operate at voltages up to 26.4V. \overline{PB} can, additionally, operate below ground ($-6V$) without latching up the device. \overline{PB} has an ESD HBM rating of $\pm 10kV$.

If the push button switch connected to \overline{PB} exhibits high leakage current, then an external pull-up resistor to V_{IN} is recommended. Furthermore, if the push button switch is physically located far from the LTC2950 \overline{PB} pin, parasitic capacitances may couple onto the high impedance \overline{PB} input. Additionally, parasitic series inductance may cause unpredictable ringing at the \overline{PB} pin. Placing a 5k resistor from the \overline{PB} pin to the push button switch would mitigate parasitic inductance problems. Placing a 0.1 μF capacitor on the \overline{PB} pin would lessen the impact of parasitic capacitive coupling.

TYPICAL APPLICATIONS

Voltage Monitoring with \overline{KILL} Input

The \overline{KILL} pin can be used as a voltage monitor. Figure 5 shows an application where the \overline{KILL} pin has a dual function. It is driven by a low leakage open drain output of the μP . It is also connected to a resistor divider that monitors battery voltage (V_{IN}). When the battery voltage falls below the set value, the voltage at the \overline{KILL} pin falls below 0.6V and the EN pin is quickly pulled low. Note that the resistor values should be as large as possible, but small

enough to keep leakage currents from tripping the 0.6V \overline{KILL} comparator.

The DC/DC converter shown has an internal pull-up current on its \overline{SHDN} pin. A pull-up resistor on EN is thus not needed.

Operation Without μP

Figure 6 shows how to connect the \overline{KILL} pin when there is no circuitry available to drive it. The minimum pulse width detected is 30 μs . If there are glitches on the resistor

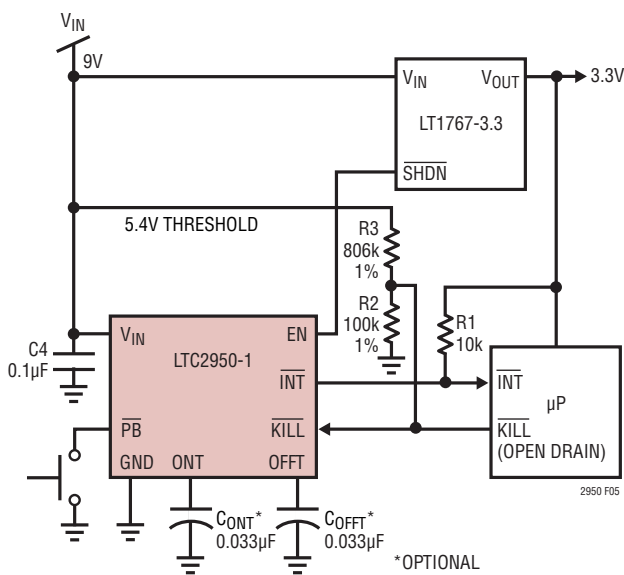

Figure 5. Input Voltage Monitoring with \overline{KILL} Input

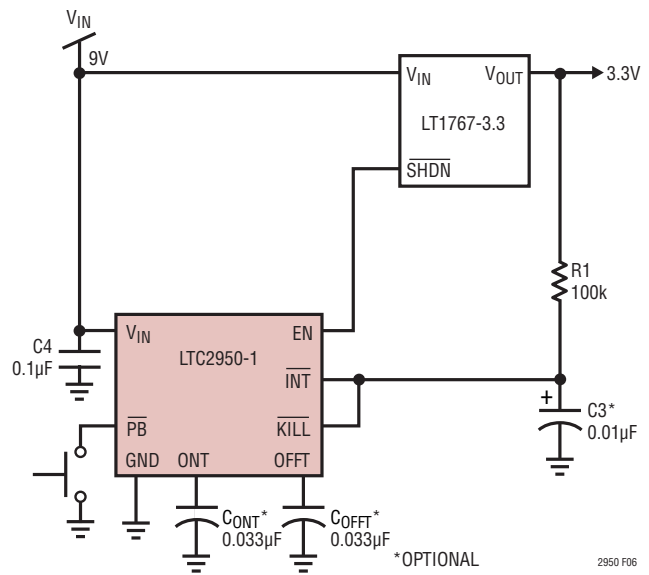

Figure 6. No μP Application

TYPICAL APPLICATIONS

pull-up voltage that are wider than 30 μ s and transition below 0.6V, then an appropriate bypass capacitor should be connected to the $\overline{\text{KILL}}$ pin.

Power Path Switching

The $\overline{\text{EN}}$ open drain output of the LTC2950-2 is designed to switch on/off an external power PFET. This allows a user to connect/disconnect a power supply (or battery) to its load by toggling the $\overline{\text{PB}}$ pin. Figure 7 shows the LTC2950-2 controlling a two cell Li-Ion battery application. The $\overline{\text{INT}}$ and $\overline{\text{KILL}}$ pins are connected to the output of the PFET through a resistor divider. The $\overline{\text{KILL}}$ pin serves as a voltage monitor. When V_{OUT} drops below 6V, the $\overline{\text{EN}}$ pin is open circuited 30 μ s later.

$\overline{\text{PB}}$ Pin in a Noisy Environment

The rugged $\overline{\text{PB}}$ pin is designed to operate in noisy environments. Transients below ground ($>-6\text{V}$) and above V_{IN} ($<30\text{V}$) will not damage the rugged $\overline{\text{PB}}$ pin. Additionally, the $\overline{\text{PB}}$ pin can withstand ESD HBM strikes up to $\pm 10\text{kV}$.

In order to keep external noise from coupling inside the LTC2950, place an R-C network close to the $\overline{\text{PB}}$ pin. A 5k resistor and a 0.1 μ F capacitor should suffice for most noisy applications (see Figure 8).

External Pull-Up Resistor on $\overline{\text{PB}}$

An internal pull-up resistor on the $\overline{\text{PB}}$ pin makes an external pull-up resistor unnecessary. Leakage current on

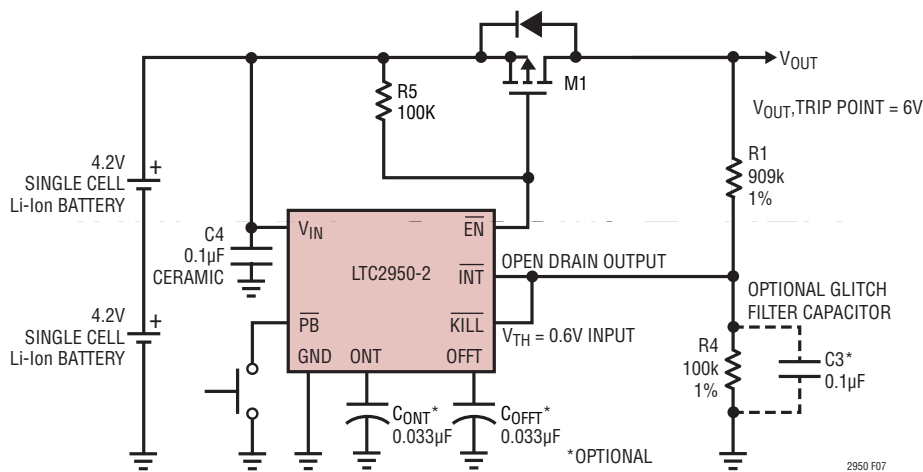

Figure 7. Power Path Control with 6V Under Voltage Detect

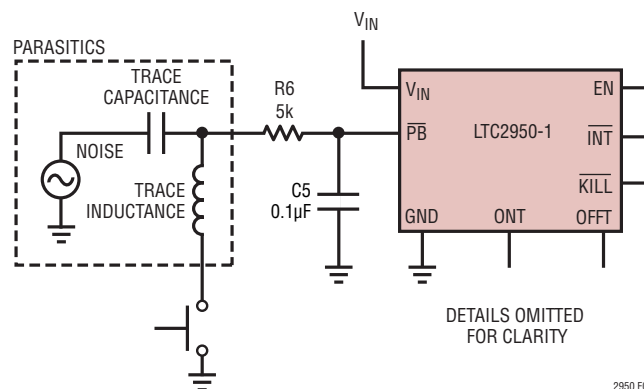

Figure 8. Noisy $\overline{\text{PB}}$ Trace

TYPICAL APPLICATIONS

the \overline{PB} board trace, however, will affect the open circuit voltage on the \overline{PB} pin. If the leakage is too large ($>2\mu\text{A}$), the \overline{PB} voltage may fall close to the threshold window. To mitigate the effect of the board leakage, a 10k resistor to V_{IN} is recommended (see Figure 9).

Reverse Battery Protection

To protect the LTC2950 from a reverse battery connection, place a 1k resistor in series with the V_{IN} pin (see Figure 10).

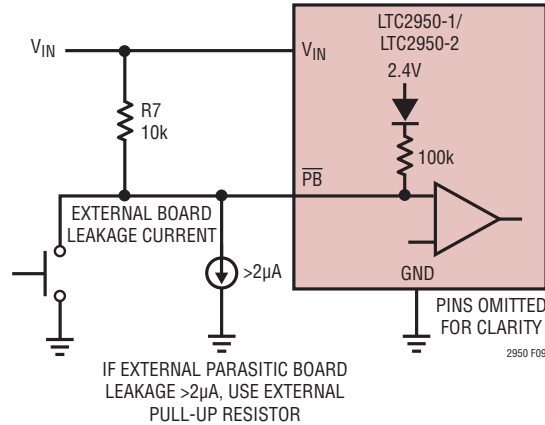
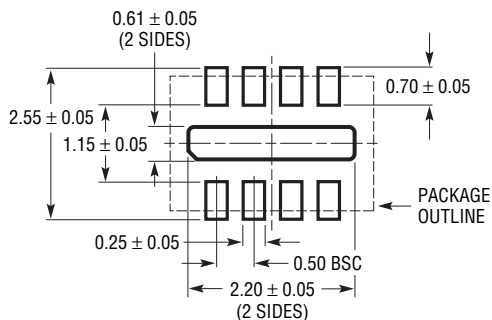

Figure 9. External Pull-Up Resistor on \overline{PB} Pin

PACKAGE DESCRIPTION

DDB Package 8-Lead Plastic DFN (3mm × 2mm) (Reference LTC DWG # 05-08-1702)



RECOMMENDED SOLDER PAD PITCH AND DIMENSIONS

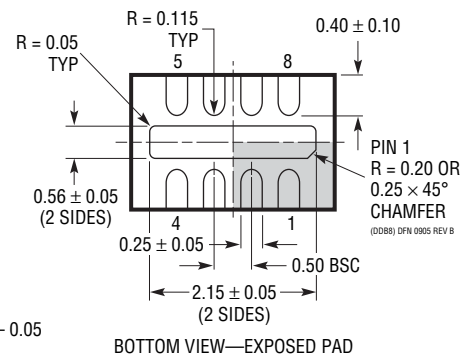
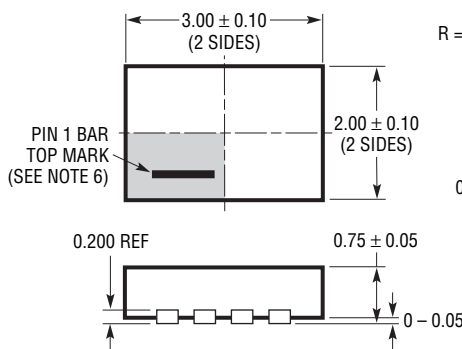

NOTE:

1. DRAWING CONFORMS TO VERSION (WECD-1) IN JEDEC PACKAGE OUTLINE M0-229
2. DRAWING NOT TO SCALE
3. ALL DIMENSIONS ARE IN MILLIMETERS
4. DIMENSIONS OF EXPOSED PAD ON BOTTOM OF PACKAGE DO NOT INCLUDE MOLD FLASH. MOLD FLASH, IF PRESENT, SHALL NOT EXCEED 0.15mm ON ANY SIDE
5. EXPOSED PAD SHALL BE SOLDER PLATED
6. SHADED AREA IS ONLY A REFERENCE FOR PIN 1 LOCATION ON THE TOP AND BOTTOM OF PACKAGE

PACKAGE DESCRIPTION

TS8 Package
8-Lead Plastic TSOT-23
 (Reference LTC DWG # 05-08-1637)

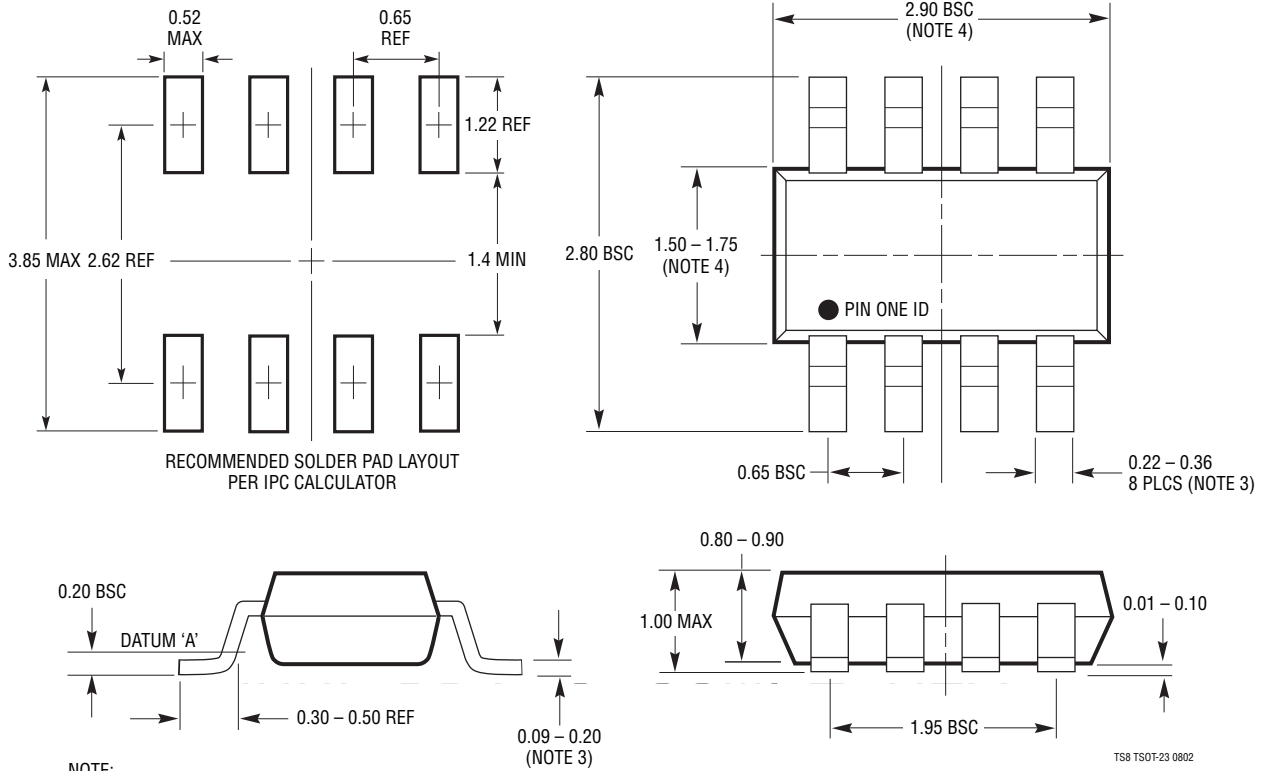

- NOTE:
1. DIMENSIONS ARE IN MILLIMETERS
 2. DRAWING NOT TO SCALE
 3. DIMENSIONS ARE INCLUSIVE OF PLATING
 4. DIMENSIONS ARE EXCLUSIVE OF MOLD FLASH AND METAL BURR
 5. MOLD FLASH SHALL NOT EXCEED 0.254mm
 6. JEDEC PACKAGE REFERENCE IS MO-193

TS8 TSOT-23 0802

